

WARRANTY CONDITIONS

Warranty Coverage :

Daedong-USA, Inc., **KIOTI** Tractor Division, herein referred to as **KIOTI**, undertakes to replace or repair any part of a **KIOTI** loader where damage has been proven to be caused by defects in material or workmanship.

This Warranty is valid for a period of 1 year from the date of the original retail sale. Parts replaced or repaired under the terms of this Warranty are guaranteed only until the original warranty expires. Warranty only applies to the original purchaser.

It is further understood and agreed that the defect should be immediately reported to the Selling Dealer. The Selling Dealer will generally perform Warranty repairs or replacements and the Purchaser shall deliver the **KIOTI** loader to the Dealer's place of business for repair.

The obligation of **KIOTI** to the Purchaser under this Warranty is limited to the repair or replacement of defective parts by an authorized **KIOTI** dealer. Repair or replacement in accordance with this Warranty shall constitute fulfillment of all liabilities of **KIOTI** and the Selling Dealer in respect to **KIOTI** loader.

There are no warranties beyond those which expressly appear herein. Any implied warranty of merchantability or fitness for a particular purpose is specifically excluded here from.





Warranty Provisions :

KIOTI's liability under this warranty is subject to the observance by the Purchaser of the following provisions:

1. The purchaser shall at all times in the operation of any **KIOTI** Product, use those brands and grades of lubricating oils, lubricants or fuel and spare parts officially approved by **KIOTI**.
2. The **KIOTI** loader shall have been used in accordance with the procedures specified in the Operator's Manual. This Warranty does not extend to damage resulting from misapplication, abuse, misuse, failure to perform maintenance, negligence, fire, accidents or changes or faulty mounting carried out by the Purchaser. When making a Warranty exchange of parts, the Purchaser shall compensate **KIOTI** for the time that the parts have been used if they have been exposed to extreme wear.
3. Compensation is not paid for physical harm, deadlock, resulting damages or other losses.
4. To obtain warranty service, the Purchaser must (1) report the product defect to an authorized **KIOTI** dealer and request repair within the applicable warranty term and (2) present evidence of purchase.
5. The Warranty shall be void if the **KIOTI** loader has been altered or repaired outside of a **KIOTI** dealership or travel of dealer personnel to customer location for Warranty repair. The customer shall also pay any premium for overtime labor requested by the dealership.
6. Temporary repairs or additional costs due to the work being performed after normal working hours will not be compensated.
7. The above warranty is in lieu of all other warranties on **KIOTI's** behalf and neither party assumes any other liability in connection with **KIOTI's** Products.
8. Any dispute arising between **KIOTI** and the Purchaser concerning the liability of **KIOTI** under this warranty shall be subject to the laws of the State of North Carolina.



Right To Make Design and Product Changes:

KIOTI reserves the right to make changes in the design and other changes in its **KIOTI** Products at any time without incurring any obligation with respect to any product previously ordered, sold or shipped.



PLEASE NOTE

Make sure all potential operators of this equipment review this manual and all safety messages contained within.

Signs		Description
	CAUTION	This safety symbol indicates important safety messages in this manual. When you see this symbol, carefully read the message that follows and be alert to the possibility of personal injury or death.
	WARNING	This mark indicates potentially hazardous situation which, if not observed, may result in death or moderate injury.
	IMPORTANT	This mark indicates emphasis on notable characteristics in working procedures or information on working procedures and technology for convenient use.
	NOTE	This mark indicates general comments or notes.





CONTENTS I

1. SAFETY PRECAUTIONS	
2. SAFETY DECALS	
3. LOADER SPECIFICATIONS	
4. INTRODUCTION	
5. TRACTOR PREPARATION	
6. LOADER OPERATION	
7. LOADER REMOVAL	
8. LOADER MOUNTING	
9. LUBRICATION AND MAINTENANCE	
10. TROUBLESHOOTING	
11. HYDRAULIC SYSTEM	
12. TORQUE TIGHTENING CHARTS	







CONTENTS II

13. PARTS ILLUSTRATIONS	████████████████████
13.1 GENERAL INFORMATION	13-2
13.2 BUCKET ASSEMBLY	13-4
13.3 QUICK ATTACHMENT	13-6
13.4 FRONT GRILL ASSEMBLY(OPTION).....	13-8
13.5 BEARING BOX ASSEMBLY	13-10
13.6 BOOM ASSEMBLY	13-14
13.7 BOOM HOSE FITTING ASSEMBLY	13-18
13.8 IN-OUT HOSE FITTING ASSEMBLY	13-20
13.9 BOOM CYLINDER ASSEMBLY	13-22
13.10 BUCKET CYLINDER ASSEMBLY	13-24
13.11 DECALS	13-28
14. LOADER INSTALLATION	████████████████████
15. INDEX	████████████████████







1. SAFETY PRECAUTIONS



SAFETY

Understand that your safety and the safety of other persons is measured by how you service and operate this loader. Know the position and operations of all controls before you try to operate. **Make sure you check all controls in a safe area before starting.**

Read this manual completely and thoroughly and make sure you understand all controls. All equipment has a limit. Make sure you are aware of the stability and load characteristics of this loader before you begin operation.

The safety information given in this manual does not replace any safety codes, insurance needs, federal, state and local laws. Make sure your machine has the correct equipment required by your local laws and regulations.

CAUTION

- **This safety alert symbol indicates important safety messages in this manual. When you see this symbol, carefully read the message that follows and be alert to the possibility of personal injury or death.**

SAFETY PRECAUTIONS

Before starting the engine of your tractor, make sure all operation controls are in park lock or neutral position.

Operate controls only when seated in the operator's seat.

Equip your tractor with a ROPS cab or frame for your protection. See your tractor operator's manual for correct seat belt usage.

A frequent cause of personal injury or death is persons falling off and being run over. Do not permit others to ride on your tractor. Only one person, the operator, should be on the machine when it is in operation.

Before leaving the tractor, stop the engine, put all controls in neutral, engage the parking brake and remove the key from the ignition.

When using remote hydraulic tractor valves on some tractors, the loader lift and dump cylinders will continue moving unless the control levers are manually returned to neutral, or until relief pressure is reached at the ends of piston strokes. Observe the bucket movement and maintain control with the control levers.

Stop the loader arms gradually when lowering or lifting loads.

Stay off of slopes too steep for safe operation. Shift down before you start up or down a hill with a heavy load. Avoid "free wheeling"

Travel speed should be such that complete control and machine stability is maintained at all times. Where possible, avoid operation near ditches, embankments and holes. Reduce speed when turning, crossing slopes, and on rough, slick or muddy surfaces.

Never use your hand to check for suspected leaks under pressure. Use a piece of cardboard or wood for this purpose. Escaping hydraulic oil or diesel fuel leaking under pressure can have sufficient force to penetrate the skin and cause infection or serious injury, seek medical attention immediately.

To prevent personal injury, relieve all pressure before disconnecting fluid lines.

Before applying hydraulic pressure, make sure all hydraulic connections are tight and components are in good condition.

Contact with overhead power lines can cause severe electrical burn or death from electrocution.

Make sure there is enough clearance between raised equipment and overhead power lines.

Add recommended rear tire liquid weight or rear wheel weights for increased stability.

A loader attachment should be transported in a low position at slow ground speeds. Make turns slowly and use the tractor brakes cautiously. A loaded attachment in the raised position alters the center of gravity location of the machine and increases the possibility of mishaps.

Do not stand, walk or work under a raised loader or attachment unless it is securely blocked or held in position. Accidental movement of a control lever or leak in the hydraulic system could cause the loader to drop, or attachment to dump, causing severe injury.

Make sure all parked loaders on stands are on a hard level surface with all safety devices engaged to prevent loader from falling and being damaged or injuring someone.

When using a loader, be alert of bucket position at all times. Loader in raised position with bucket rolled back can dump material on tractor causing damage or injury to tractor and / or operator.

Always park loader with bucket attached to loader.





2. SAFETY DECALS



SAFETY DECALS

Safety Decal Locations

⊕ IMPORTANT

- Warning decals CK12-3001, located on the left hand Mid-Mount and Warning Decal CK12-3002, CK12-3003 located on the loader right hand Mid-Mount are visible when getting on tractor.

Care of Safety Decals.

1. Keep safety decals clean and free of obstructing material.
2. Clean safety decals with soap and water and dry with a soft cloth.
3. Replace damaged or missing safety decals with new decals from your KIOTI Dealer.
4. If a component with a safety decal(s) affixed is replaced with a new part, make sure new safety decal(s) are attached in the same location(s) as the replaced components.
5. Mount new safety decals by applying on a clean dry surface and pressing air bubbles to outside edges.

(1) Part No : CK12-3004



(2) Part No : LP30-5002



(3) Part No : CK12-3001

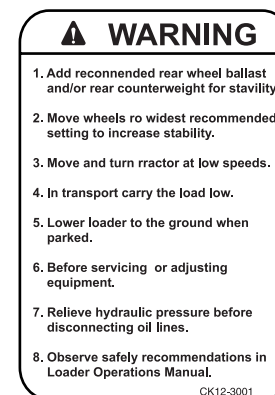

(4) Part No : CK12-3003

⚠ WARNING

1. Add recommended rear wheel ballast and/or rear counterweight for stability.
2. Move wheels to widest recommended setting to increase stability.
3. Move and turn tractor at low speeds.
4. In transport carry the load low.
5. Lower loader to the ground when parked.
6. Before servicing or adjusting equipment.
7. Relieve hydraulic pressure before disconnecting oil lines.
8. Observe safety recommendations in Loader Operations Manual.

CK12-3003

(5) Part No : CK12-3002

⚠ WARNING

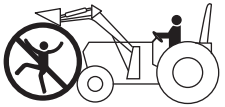

Crushing Hazard

Stay away from under lift arms and bucket!

1. Do not stand or work under a raised loader.
2. Support bucket and lift arms before working under loader.
3. Lower loader to the ground before leaving seat.

CK12-3002

(6) Part No : CK12-5001

KIOTI Pure Animal

Daedong-USA INC,
6300 Kioti Drive
Wendell, NC USA

Model No.

Serial No.

www.kiotitractor.com





3. LOADER SPECIFICATIONS



3-2 KL130

LOADER SPECIFICATIONS

Specifications and design are subject to change without prior notice.

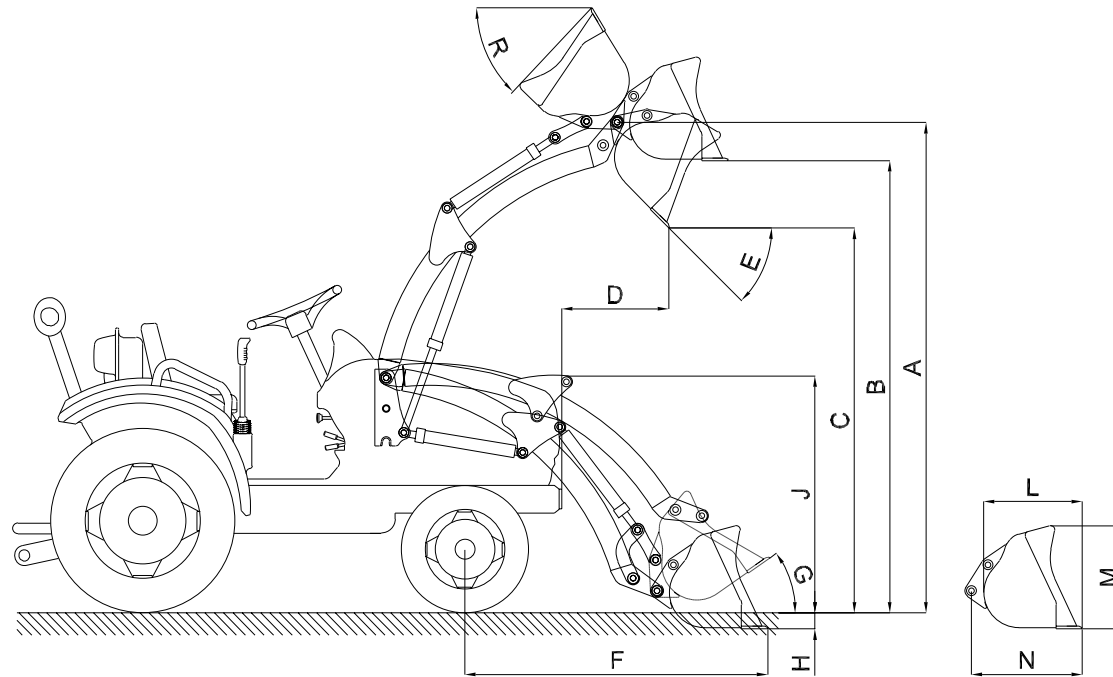

1300301A

Loader Model	KL130
Tractor Model	CK25/30

LOADER SPECIFICATIONS 3-3

A	Maximum Lift Height	2,350 mm	92.5 in.
B	Clearance with Attachment Level	2,177 mm	85.7 in.
C	Clearance with Attachment Dumped	1,870 mm	73.6 in.
D	Reach at Maximum Height 45°	452 mm	17.8 in.
E	Maximum Dump Angle	52 degree	←
F	Reach with Attachment on Ground	1,521 mm	59.88 in.
G	Attachment Rollback Angle	37degree	←
H	Digging Depth Below Grade	135 mm	5.31 in.
J	Overall Height in Carry Position	1,260 mm	49.60 in.
L	Depth of Attachment (to back of inner shell)	450 mm	17.71 in.
M	Height of Attachment	470 mm	18.50 in.
N	Depth of Attachment (to pivot pin)	507 mm	19.96 in.
R	Over Tilt Degree	38 degree	←
S	Lift Capacity to Full Height at Pivot Pins	525 kgf	1,155 lbs
T	Breakout Force at Pivot Pins	930 kgf	2,046 lbs
	Lift Cylinder	ø 45 mm X 612 mm	1.77 X 24.09 in.
	Bucket Cylinder	ø 45 mm X 589 mm	1.77 X 23.18 in.
	Bucket Width	1,524 mm	60 in.
	Bucket Weight	76 kg	167.5 lbs
	Approx. Weight (without Bucket)	251 kg	552.2 lbs
	Bucket Capacity	0.27 m ³ (0.20 m ³)	9.53 cu.ft (7.06 cu.ft)





4. INTRODUCTION



INTRODUCTION

The purpose of this manual is to assist you in maintaining and operating your KIOTI loader. Read it carefully, it furnishes information and instructions that will help you achieve years of dependable performance. Some information may be general in nature due to unknown and varying conditions. However, through experience and these instructions, you should be able to develop operating procedures suitable to your particular situation.

"Right" and "Left" as used throughout this manual are determined by facing the direction the machine will travel when in use.

The photos, illustrations and data used in this manual are current at the time of printing, but due to possible in-line production changes, your machine may vary slightly in detail. The manufacturer reserves the right to redesign the machine as may be necessary without notification.

⊕ IMPORTANT

- **Illustrations used in this manual may not show all safety equipment that is recommended to ensure safe operation of tractor and loader. Refer to the Safety Precautions section of this manual for information concerning safety. consult your dealer for further information.**

Warranty Registration

The Delivery and Warranty Registration forms must be filled out and signed to validate your warranty protection. The items on the form under "I hereby Acknowledge" should be read and understood. The terms and conditions of the warranty on this machine are specified in the front of this manual.

Serial Number and Location

The serial number is important information about the machine and it may be necessary to know it before obtaining the correct replacement part. The serial number is located on the right side of loader sub_frame. The serial number should be recorded on the Delivery and Registration form and also below for your reference.

KIOTI KL130 Loader Serial Number Information

Date Purchased _____

Loader Serial Number _____

Dealer Name and Telephone Number _____



5. TRACTOR PREPARATION



TRACTOR PREPARATION

Rear Counterweight

 **CAUTION**

- **Add recommended rear tire liquid weight, rear wheel or rear ballast for increased stability.**
- **Do not exceed the manufacturer's rating for maximum gross vehicle weight.**
Refer to Operator's Manual or ROPS serial plate provided with tractor.

The use of adequate counterweight to counter balance for maximum loader capacity is required for safe loader operation.

Weight added to rear of the tractor provides better traction and easier, more efficient loader operation. The tractor can be counter weighted by filling rear tires with liquid calcium solution and/or by the installation of rear wheel weights.

Additional counterweight requirements will vary with loader attachments and equipment applications. Additional weight can be added by installation of Three Point Hitch mounted ballast.

 **CAUTION**

- **Certain specific conditions may not permit safe use of loader at loader rating or may require more careful restricted operation at the rated load.**

Refer to Tractor Operator's Manual for specific recommendations on counterweight tractor.

ROPS System

The tractor must be equipped with an approved ROPS System to ensure adequate operator's protection.

Tractor Hydraulic System

Tractor operation in a loader application significantly increase demands on the tractor Hydraulic System. Check the tractor Hydraulic system fluid level daily. Refer to your tractor Operator's Manual maintenance section for instructions regarding tractor hydraulic system maintenance.

Adhere to recommendation in your Tractor Operator's Manual concerning hydraulic fluid and filter specifications, and change intervals.

 **CAUTION**

- **The tractor/loader must only be operated with all safety equipment properly installed.**

TRACTOR TIRES

Selection of tires(size, profile, tread type) should be restricted to tire recommendations as specified by KIOTI.

Tire Inflation

Front tires must be maintained at the maximum recommended inflation to maintain normal tire profile with the added weight of loader/material.

Rear tires must be maintained at equal pressure within the recommended tire inflation range. Unequal rear tire inflation can prevent loader attachment from contacting the ground across its full width.

Wheel Tread Settings

Tractor front wheel tread setting must be restricted to wheel tread spacing recommended in the tractor Operator's Manual.

Front Counterweight

Use of front counterweight is not recommended when tractor is being used in a loader application. Front counterweight adds unnecessary front axle load in loader applications.





6. LOADER OPERATION



LOADER OPERATION

CAUTION

- **The tractor/loader should only be operated with all safety equipment properly installed.**

Precautionary Notes

Do not lower the edge of the bucket too low for loading. Keep the bottom of the bucket level with the ground when loading.

IMPORTANT

- **Do not use the bucket for pushing down material with bucket cylinders partially extended. Damage to the cylinders may result.**
- **Do not tip bucket cutting edge down (fully extended bucket cylinders) during backfilling/backgrading operations.**
- **Operation with front tractor wheels off the ground is not recommended.**
- **Position vehicle to be loaded as near the pile as possible and in such a direction as to minimize the amount of tractor turning required to dump.**
- **Do not lower the loader with the tractor engine shut off.**
- **Keep the unit clean and perform regular service. Observe safety messages whenever cleaning, servicing, or lubricating.**

We urge you to follow this advice:

1. Read and understand this manual as well as the Tractor Operator's Manual.
2. Remember and observe the Safety Precautions brought to your attention in this manual, the tractor manual and on the machinery itself.
3. Use good common sense in the everyday operation of this unit. Safety recommendations can never be all-inclusive and you are responsible for watching out for and avoiding unsafe conditions.
4. Never exceed the limits of a piece of machinery. If its ability to do a job or to do so safely is in question, don't try it.
5. Don't hurry the learning process or take the unit for granted. Ease into it and become familiar with your new loader and tractor.

CAUTION

- **When lowering a heavy load, ease it downward slowly. Never drop a loaded attachment and "catch it hydraulically". Stopping a load after it has gained downward momentum places undue strain on the unit and may cause unnecessary damage to the loader or tractor or even worse, personal injury.**

⚠ CAUTION

- **Before disconnecting hydraulic lines, relieve all hydraulic pressure. Escaping hydraulic oil under pressure can have sufficient force to penetrate the skin causing serious personal injury. If injured by escaping hydraulic oil seek medical attention immediately.**
- **Do not operate the loader if the fittings are leaking or if the hoses are damaged. A sudden line burst would cause the mainframe to drop suddenly, causing damage to the tractor or loader or injury to personnel.**

Initial Loader Operation

Before operating the loader, fully raise and lower the boom two or three times. Then raise the bucket approximately (4)feet above the ground and cycle the bucket cylinders three times. Lower the bucket to the ground. Check the tractor hydraulic oil and the correct oil level.

⚠ CAUTION

- **Before leaving the machine, stop the engine, remove the key, place all controls in neutral, and either set the parking brake or place tractor in park as equipped.**

Always keep cylinders in a retracted position when the loader is not in use to guard against rust and contamination which may cause damage to the cylinder rods or hydraulic system.

Cold Weather Operation

For smooth operation in cold weather, let the tractor warm up. Slowly cycle the lift and bucket cylinders several times to warm the oil in the hydraulic system. The loader may operate erratically until the hydraulic oil has warmed to operating temperatures.

⚠ CAUTION

- **Operate controls only when seated in the operator's seat.**

Loading Bucket

For the most efficient loading, slowly drive the tractor straight into the material to be loaded and increase speed only after contact has been made. Roll the attachment back a small amount and slowly lift to break away the material. As the load increase, continue rolling the attachment back so as to get the maximum load. Remove the top levels first when loading from large piles of material. When bucket is full, raise loader so the bucket is clear of material and slowly back out of the pile.

Dumping Bucket

When in the dump area slowly drive the tractor forward and raise the loader at the same time. Raise the loader to the height needed to dump the bucket. Make sure to keep a level bucket position to prevent spilling from the bucket. Dump the bucket, and keep all movements smooth.

Transporting a Loaded Bucket

Transport material with the bucket as low as possible to prevent spilling and keep maximum stability. The loader must be in a position that will not block the operators' vision. A loaded bucket must not be transported in the upright position or at excessive speed.

Observe the following safety warning when transporting a loaded bucket.

CAUTION

- When using a loader, be aware of bucket location at all times. When raising a loader with bucket rolled back, material can dump onto tractor causing damage to tractor or injury to operator.
- Stop the loader arms gradually when lowering or lifting.
- Do not stand, walk or work under a raised loader unless it is securely blocked or held in position. Accidental movement of a control lever or leak in the hydraulic system could cause the loader to drop, or attachment to dump, resulting in serious injury or death.

WARNING

- *Contact with overhead power lines can cause severe electrical burns or death from electrocution. Make sure there is clearance between raised equipment and overhead power lines.*
- *A loaded Bucket should be transported in a low position at low ground speeds. Make turns slowly and use the tractor brakes cautiously. A full bucket in the raised position alters the center of gravity location of the machine and increases the possibility of accidents.*

Scraping

When scraping, the Boom lever must be used to keep the bucket on the ground horizontally. The bucket must be kept level to the ground during scraping operations.

Backfilling/Backgrading

When "Backfilling" or "Backgrading", position the bucket so it is level on the ground. Do not dump material from bucket following each pass, as additional weight of material in bucket will assist in "Backgrading" and increase loader efficiency during "Backfilling".

Controlled Rate of Loader Functions

By "feathering" the control lever, reduced operational speeds can be controlled. This action controls the position of the valve spool in the valve body and regulates flow of oil to/from cylinders. It is important to utilize this operational practice when lowering loader boom when the bucket is loaded with material.

Loader Hydraulic Controls

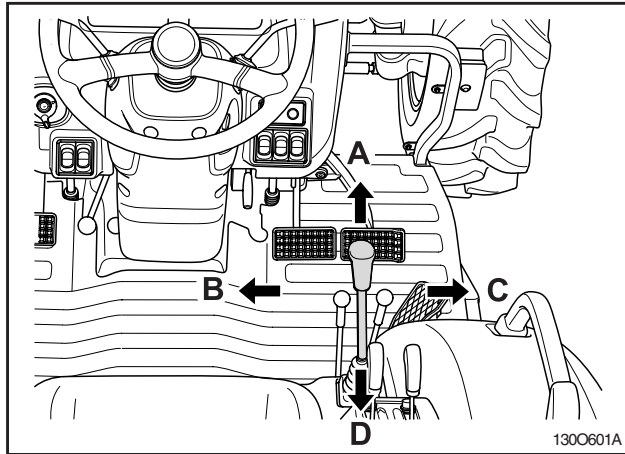

(A) Forward-Float Low
(B) Left-Bucket Retract
(C) Right-Bucket Dump
(D) Rear-Raise

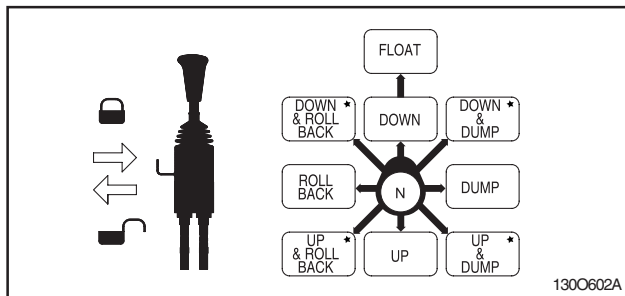

The Single lever joystick control lever is mounts on the CK25/30 From the factory.

The control lever has the safety lock function.

Lock the control lever when leaving the tractor while the Bucket is in the air.

The loader hydraulic valve lift Cylinder circuit incorporates a "float" position which allows the loader bucket to follow ground contours. The "float" position is engaged by shifting the control lever forward into "detent" until the operator pulls the control lever out of the "Detent" position.

Refer to "Scraping" operation for recommended use of "float" position.

The control valve has a neutral position that prevents movement of loader or bucket.

When the control valve is released from the work position, the spool will return to neutral.

⊕ IMPORTANT

- **Contaminates in hydraulic oil can cause valve spools to stick. Be alert when operating loader and follow your Tractor Operator's Manual maintenance schedule.**





7. LOADER REMOVAL



LOADER REMOVAL

CAUTION

- Never park loader without bucket attached to the loader.
- Never allow weight of tractor to be put on parking leg when removing loader.

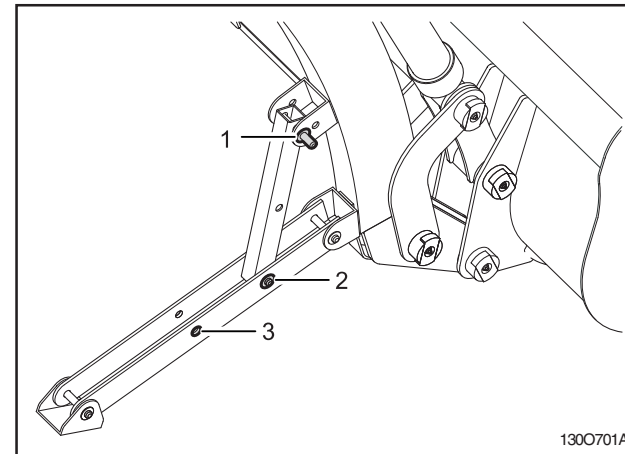

(1) Long Pivot Pin
(3) Packing Leg

(2) Short Pivot Pin

- STEP 1.** Park the tractor and loader on hard level surface.
- STEP 2.** Raise the boom until the bucket is about 2 feet off the ground.
- STEP 3.** Set the parking legs with pivot pin and Keeper.
- STEP 4.** Lower the boom until the Parking legs make contact on the ground. Tip the bucket until the bucket cutting edge touch the ground.

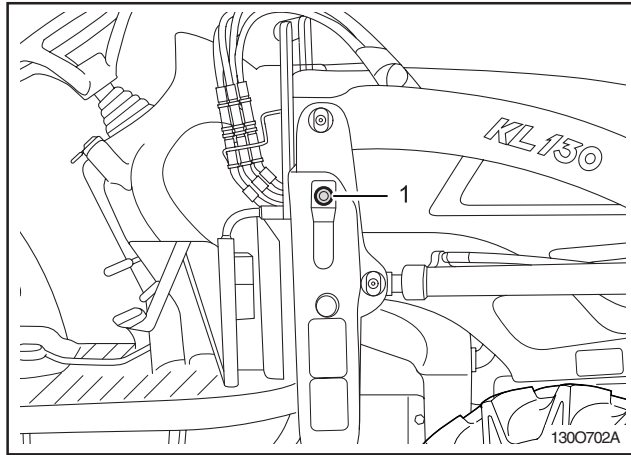

(1) Latch Pin

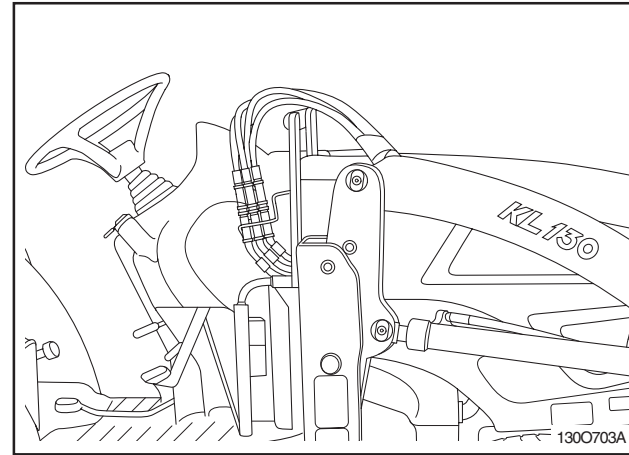

STEP 5. Remove the latch pin while move the control lever back and forth slightly to make the latch pin easy.

STEP 6. Pull the control lever to raise the loader until the inner bearing box.

Adjust the bucket until the bottom surface of bucket touch the ground.

STEP 7. Move the tractor backward slowly and stop to avoid the hydraulic hoses being tighten.

STEP 8. Stop the engine and move the control lever back and forth, left and right several times to reduce the hydraulic pressure in the hoses.

STEP 9. Disconnect the quick couplers on the hydraulic hoses.

7-4 KL130

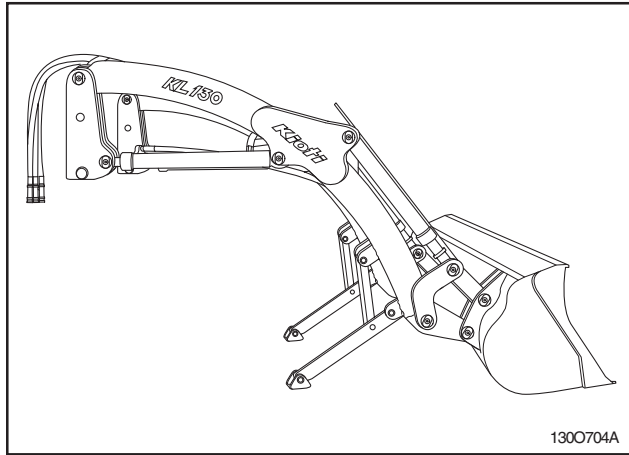



8. LOADER MOUNTING



LOADER MOUNTING

⚠ CAUTION

- Never allow weight of tractor to be put on parking leg when mounting loader.

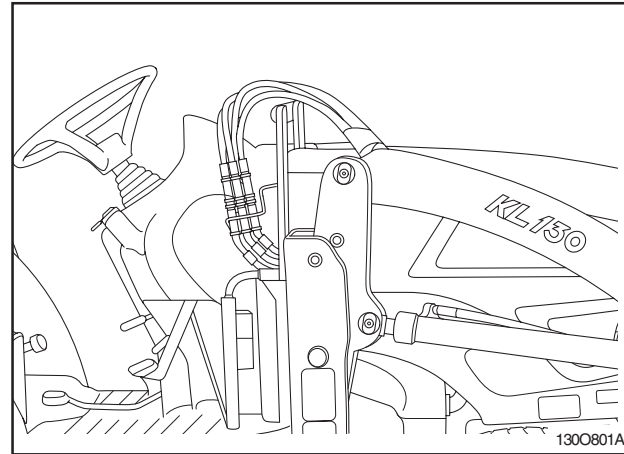

- STEP 1.** Carefully drive the tractor into the loader to a position where the hydraulic hoses(Quick coupler) can be connected to the control valve block.
- STEP 2.** Stop the engine and move the control lever back and forth, Left and right several times to reduce the pressure in the hydraulic hoses.
Connect the hydraulic couplers match the color code rings.
- STEP 3.** Start the engine and move the boom and bucket to adjust the height of inner bearing box.
Be sure to check the hook of inner bearing box is slightly higher than the pin welded on outer bearing box .

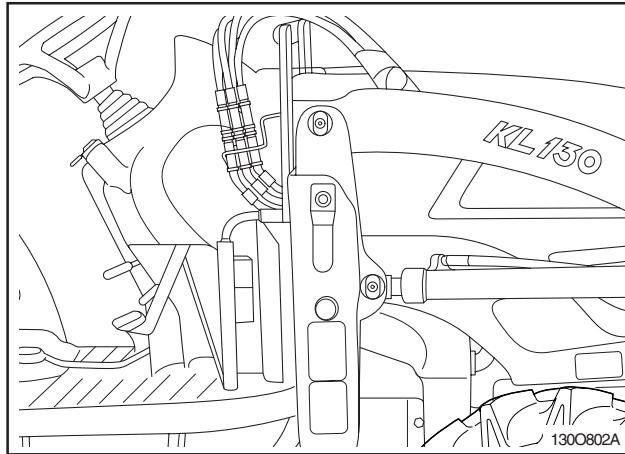

STEP 4. Move the tractor forward to put the inner bearing box into the outer bearing box. Stop the tractor when the hook is right over the pin.

Lower the inner bearing box with moving the boom and bucket until it hooked securely each other.

STEP 5. Align the latch pin holes with moving the bucket and boom. Insert the latch pins.

Rubber hammer can be used to put the pin in if needed.

STEP 6. Remove pin and keeper holding the parking legs and return to storage position. Make secure by using pin and keeper.





9. LUBRICATION AND MAINTENANCE



LUBRICATION AND MAINTENANCE

CAUTION

- Do not perform and service or maintenance Operations with loader raised off the ground. For additional access to tractor components remove loader.

IMPORTANT

- Lower the loader to the ground and relieve pressure in loader hydraulic lines prior to performing any service or maintenance operations on the tractor or loader.

CAUTION

- Escaping fluid under pressure can have sufficient force to penetrate the skin, causing serious injury. Before disconnecting lines, be sure to relieve all pressure. Before applying pressure to the system, be sure all connections are tight and that lines, pipes and hoses are not damaged. Fluid escaping from a very small hole can be almost invisible. Use a piece of cardboard or wood rather than your hands to search for suspected leaks. If injured by escaping fluid, seek medical attention immediately. Serious infection or reaction can develop if correct medical treatment is not administered immediately.

Refer to "Lubrication and Maintenance Chart" for quick reference to Maintenance Operations.

WARNING

- Do not operate the loader if the fittings are leaking or if the hoses are damaged. A sudden line burst could cause the mainframe to drop suddenly, causing damage to the tractor or loader or injury to personnel.
- Operate the loader from the tractor seat only.
- Do not stand or walk under a raised loader. Accidental movement of control lever or leak in hydraulic system could cause mainframe to drop, causing severe injury.

Check the tractor hydraulic system as outlined in the Tractor Operator's Manual.

NOTE

- When checking hydraulic system oil level, the loader should be on the ground and bucket fully retracted(all cylinders in retracted position).
- Grease all loader pivot points daily(or every day 10 hours). Refer to Tractor Operator's Manual for lubricant recommendations.
- Inspect hydraulic hoses, connections, control valve and cylinders for evidence of leakage.
- Tractor tires should be maintained at maximum recommended inflation to maintain normal tire profile with added weight of loader/material. Unequal rear tire inflation can result in bucket not being level to the ground.

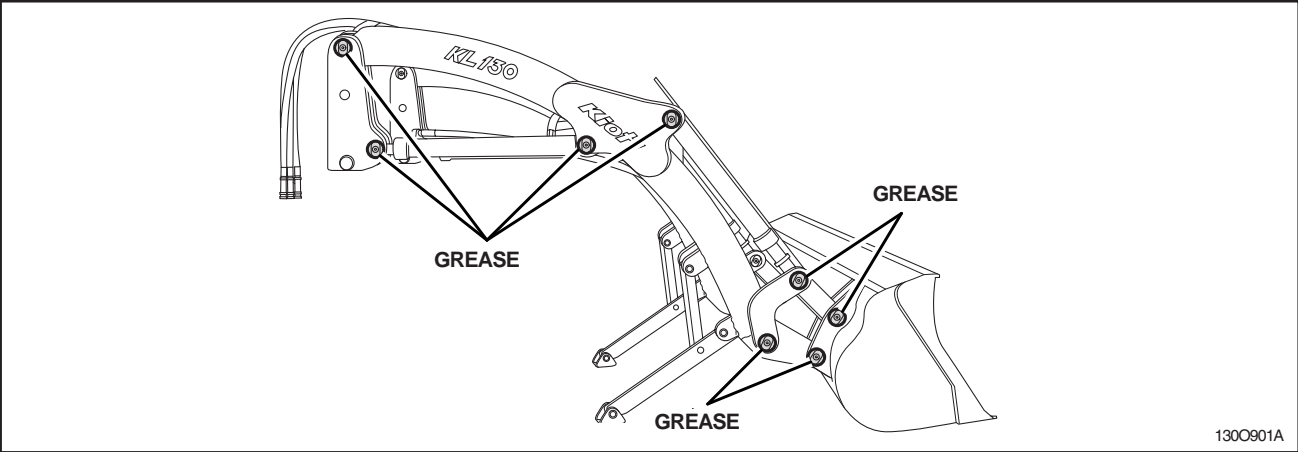

ITEM	SERVICE	SERVICE INTERVAL
Hydraulic System Oil Level	Check	Daily/10 hours
Hydraulic System Oil/Filter	Replace	As specified in Tractor Operator's Manual
Tire Inflation	Check	Weekly/50 hours
Loader Pivot Points	Lubricate	Daily/10 hours
Loader Hydraulic Lines, Hoses, Connections	Check for leaks, wear	Daily/10 hours
Lift and Bucket cylinder rod packings	Check for seepage, service as needed	Daily/10 hours
Pivot pin bolts and dust covers	Check, replace if missing	Daily/10 hours
Mid-Mount latch and lynch pins	Check, replace if necessary	Daily/10 hours
Loader mount hardware	Check visually	Daily/10 hours
Loader mount hardware	Re-torque	Every 25 hours





10. TROUBLESHOOTING



TROUBLESHOOTING

This Troubleshooting Chart is provided for reference to possible loader operational problems.

Determine the problem that best describes the operational problem being experienced and eliminate the possible causes as listed by following the correction procedures.

Problem	Possible Cause	Correction
Lift and Bucket cylinders inoperative.	Low hydraulic fluid level.	Check and replenish hydraulic fluid.
	Hydraulic hoses connected improperly.	Check and correct hydraulic hose connections.
	Hydraulic hoses to/from control valve blocked	Check for damage(kinked) hoses, etc.
	Loader control valve or tractor main relief valve stuck open.	Check system pressure. Repair or replace relief valve.
	Low system pressure supplied from hydraulic pump.	Check system pressure. Repair or replace pump.
	Control valve linkage broken.	Inspect. Repair as required.
	Quick disconnect coupler(s) are not fully connected or "Flow Check"	Check coupler connections. Replace coupler(s) if necessary.
	Hydraulic hose or tubeline blockage.	Check for evidence of damage to hoses or tubelines that would block flow of oil between cylinders and control valve.
	Cylinder piston assembly defective(not sealing)	Check cylinders for internal leakage as described in service section under cylinder leakage tests.
Control valve blockage.	Inspect for blockage. Disassemble valve if necessary.	

Problem	Possible Cause	Correction
Lift and/or Bucket Cylinders operate in wrong direction relative to control lever position.	Hydraulic hoses connected incorrectly.	Correct hydraulic hose connections.
Slow or erratic lift	Low hydraulic fluid level.	Check and replenish hydraulic fluid.
	Cold hydraulic fluid.	Allow hydraulic system to warm up to operating temperature.
	Engine R.P.M. too slow(hydraulic pump R.P.M. too slow).	Increase engine speed to obtain satisfactory loader operation.
	Excessive weight in bucket. Material weight exceeds maximum specified loader capacity.	Reduce material load.
	Control valve linkage binding/defective.	Check control valve linkage and repair if worn/defective.
	Aeration of hydraulic fluid	Refer to "Aeration of Hydraulic Fluid".
	Quick disconnect coupler restriction or coupler "Flow checks"	Check coupler connections. Repair or replace.
	Hydraulic hose or tubeline restriction (hoses/tubeline) kinked or pinched.	Check hoses and tubelines for evidence of restriction.
	Lift cylinder piston assembly leakage.	Check cylinders for leakage. Repair as needed.

Problem	Possible Cause	Correction
Slow or erratic lift	Relief valve erratic or set below specifications.	Check and reset relief valve. Setting as needed.
	Control valve leaking internally. (hypassing fluid within valve).	Replace control valve and recheck operation.
	Inadequate hydraulic pump capacity.	Refer to "Hydraulic Pump Capacity Inadequate"
Inadequate lifting capacity	Engine R.P.M. too slow.	Increase engine R.P.M.
	Excessive load - material weight exceeds specified loader capacity.	Reduce Load.
	Relief valve setting below specifications.	Check and reset relief valve setting as needed.
	Lift cylinder piston assembly leakage.	Check cylinders for leakge. Repair as needed.
	Control valve leaking internally	Replace control valve and recheck operation.
	Hydraulic pump defective.	Refer to "Hydraulic Pump Capacity Inadequate".
Aeration of Hydraulic Fluid (Generally indicated by foamy apperance of fluid).	Low hydraulic fluid level.	Check and refill hydraulic system to proper level.
	Air leaking into suction side of hydraulic pump.	Check for loose or defective connections between reservoir and hydraulic pump.
	Hydraulic fluid foaming due to improper hydraulic oil usage.	Refer to Tractor Operator's Manual and replace hydraulic oil using recommended hydraulic oil.

Problem	Possible Cause	Correction
System relief valve squeals.	Cold Hydraulic Fluid.	A low hydraulic fluid to warm up to operating temperature.
	Excessive load in bucket. Weight exceeds specified loader capacity.	Reduce load.
	Relief valve setting below specifications.	Check and reset valve setting as needed.
	Hydraulic hose, tubeline or quick disconnect coupler restriction.	Check for evidence of restriction in hydraulic oil flow. Repair or replace defective components.
Loader drops with control valve spool in "centered" position (no external oil leakage evident.) Note: A gradual drop over an extended period of time is a normal condition.	Cylinder piston assembly leakage.	Check cylinders for leakage.
	Control valve internal leakage.	Replace control valve and recheck.
Control valve spool(s) will not return to centered position.	Control lever linkage binding.	Determine origin of binding and repair.
	Control valve spool centering is broken.	Replace centering spring.
	Control valve spool binding in valve body spool bore.	Disassemble valve for inspection and repair.

Problem	Possible Cause	Correction
External hydraulic fluid leakage.	Loose hydraulic connection.	Tighten loose connections.
	Defective hydraulic hose, tubeline, adapter fitting or adapter fitting o-ring.	Check for origin of oil leak and replace defective part.
	Control valve o-rings defective.	Replace defective o-rings.
	Control valve spool or body damaged or worn.	Replace control valve.
	Cylinder rod packing set leakage.	Check cylinders for leakage. Repair as needed.
Hydraulic pump capacity inadequate.	Cold hydraulic fluid.	Allow hydraulic fluid to warm up to operating temperature.
	Engine R.P.M. too slow.	Increase engine R.P.M.
	Low hydraulic fluid supply.	Refer to Tractor Operator's Manual for service recommendations.
	Hydraulic hose restriction.	Check for evidence of restriction in hydraulic hoses.
	Hydraulic pump defective.	Refer to Tractor Operator's Manual for recommended service procedures. Replace hydraulic pump if determined to be defective.
Lift cylinder rod bend when lift cylinders extended.	Excessive shock load on lift cylinders during transport.	Replace defective parts. Review and observe proper and safe operational practices.

Problem	Possible Cause	Correction
Bucket cutting edge wear is uneven side to side	Bucket is not level to ground.	Check rear tire inflation and adjust to level bucket to ground.
Bucket cutting edge wear rate is excessive. (Wear rate is even across full width of bucket). Note: Extensive use of bucket on concrete or asphalt surfaces will accelerate wear rate of bucket cutting edge.	Incorrect operational practices. Excessive down pressure placed on bucket when being used on hard abrasive surfaces.	Refer to operation-scraping section for correct operating procedures. Utilize float position.
	Bucket wear pads worn.	Replace wear pads.





11. HYDRAULIC SYSTEM SCHEMATIC



HYDRAULIC SYSTEM SCHEMATIC
AUXILIARY HYDRAULIC VALVE PACKAGE CAUTION

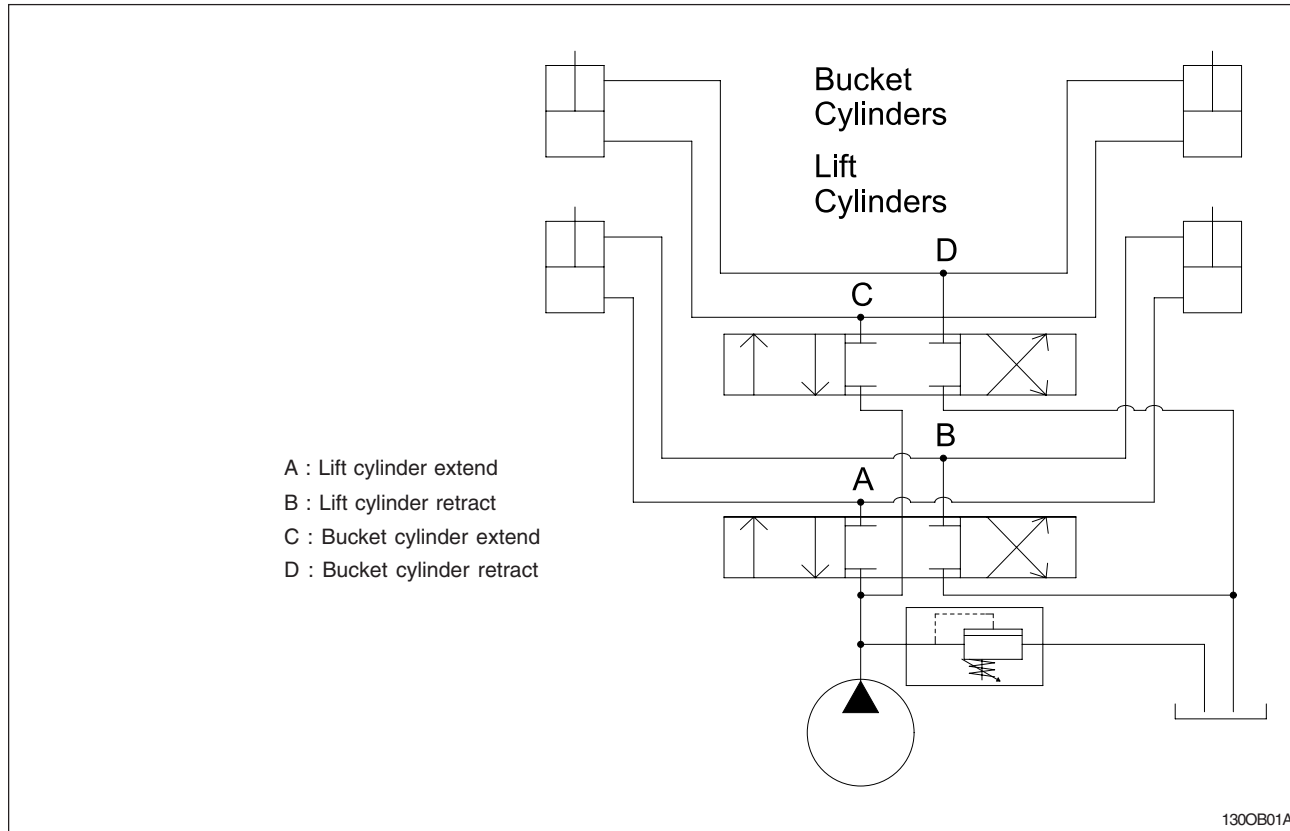









12. TORQUE TIGHTENING CHARTS



TORQUE TIGHTENING CHART 1

SAE FASTENER TORQUE CHART													
Note : Use these torques, unless special torques are specified. Values are for UNC and UNF thread fasteners, plated or unplated as received from supplier. Fasteners can be dry or lubricated with normal engine oil. Values do not apply if graphite, molydisulphide or other extreme pressure lubricant is used.													
SAE Grade No.	2				5				8*				
Bolt head identification (see note 1)													
Bolt Size	FT LBS		Nm		FT LBS		Nm		FT LBS		Nm		
	Min.	Max.	Min.	Max.	Min.	Max.	Min.	Max.	Min.	Max.	Min.	Max.	
1/4	5	6	7	8	9	11	12	15	12	15	16	20	
5/16	10	12	14	16	17	20.5	23	28	24	29	33	39	
3/8	20	23	27	31	35	42	48	57	45	54	61	73	
7/16	30	35	41	47	54	64	73	87	70	84	95	114	
1/2	45	52	61	70	80	96	109	130	110	132	149	179	
9/16	65	75	88	102	110	132	149	179	160	192	217	260	
5/8	95	105	129	142	150	180	203	244	220	264	298	358	
3/4	150	185	203	251	270	324	366	439	380	456	515	618	
7/8	160	200	217	271	400	480	542	651	600	720	814	976	
1	250	300	339	406	580	696	787	944	900	1080	1220	1464	
1-1/8					800	880	1085	1193	1280	1440	1736	1953	
1-1/4					1120	1240	1519	1681	1820	2000	2468	2712	
1-3/8					1460	1680	1980	2278	2380	2720	3227	3688	
1-1/2					1940	2200	2631	2983	3160	3560	4285	4827	

Note 1: Bolt head identification marks as per grade. Manufacturing marks will vary. *Thick nuts must be used with Grade 8 bolts.

TORQUE TIGHTENING CHART 2

METRIC FASTENER (ISO) TORQUE CHART												
Note : Use these torques, unless special torques are specified. Values are for course thread fasteners, plated or unplated as received from supplier. Fasteners can be dry or lubricated with normal engine oil. Values do not apply if graphite, moly-disulphide or other extreme pressure lubricant is used.												
ISO Class No.	8.8				10.9				12.9			
Bolt head identification (see note 1)	8.8				10.9				12.9			
Bolt Size	Nm		FT LBS		Nm		FT LBS		Nm		FT LBS	
	Min.	Max.	Min.	Max.	Min.	Max.	Min.	Max.	Min.	Max.	Min.	Max.
M4	3	4	2	3	4	5	3	4	Because of the low ductility of these fasteners, the torque range is to be determined individually for each application. As a general rule, the torque ranges specified for grade 10.9 fasteners can be used satisfactorily on 12.9 fasteners. * M14 is not a preferred size.			
M5	6.5	8	5	6	9.5	11	7	8				
M6	10.5	12	8	9	15	17.5	11	13				
M8	26	31	19	23	37	43	27	32				
M10	52	61	38	45	73	87	54	64				
M12	90	107	66	79	125	150	93	112				
*M14	144	172	106	127	200	245	149	179				
M16	217	271	160	200	310	380	230	280				
M20	434	515	320	380	610	730	450	540				
M24	675	815	500	600	1050	1275	780	940				
M30	1250	1500	920	1100	2000	2400	1470	1770				
M36	2175	2600	1600	1950	3500	4200	2580	3090				

Note 1: Bolt head identification marks as per grade. Manufacturing marks will vary. *Thick nuts must be used with Grade 8 bolts.





13. PART ILLUSTRATIONS



GENERAL INFORMATION

Illustrations

All parts are illustrated in "exploded views" which show the individual parts in their normal relationship to each other. Reference numbers are used in the illustrations. These numbers correspond to those in the "Reference Number" column and are followed by the quantity required and description.

Directional Reference

"Right hand" and "left hand" sides are determined by standing at the rear of the unit and facing in the direction of forward travel.

Parts Order



Orders must give the complete description, correct part number, the total amount required, the product model, all the necessary serial numbers, the method of shipment and the shipping address.

Instructions

1. GROUP NAME
: Detail classification name for parts.
2. SECTION NAME
: Classification name for parts.
3. COMPONENTS
: The components of an assembly are identified by a bracket.
4. NO.
: Reference numbers are assigned to parts in the figure.

INTERCHANGEABILITY

: Indicates the interchangeability of parts due to design change.

	Indicates that a new part can be used instead of an old part when you order this part, please order new part.
	Indicates that either parts can be used.
 ~4265-99999 5265-00001~	Indicates that a part has a serial number break. When you order this part, please order a part according to the serial number of the Loader.

★ Due to our policy of continuously improving products, The information contained herein is subject to change without notice.

13.2 BUCKET ASSEMBLY

UPDATED(03.31.2009)

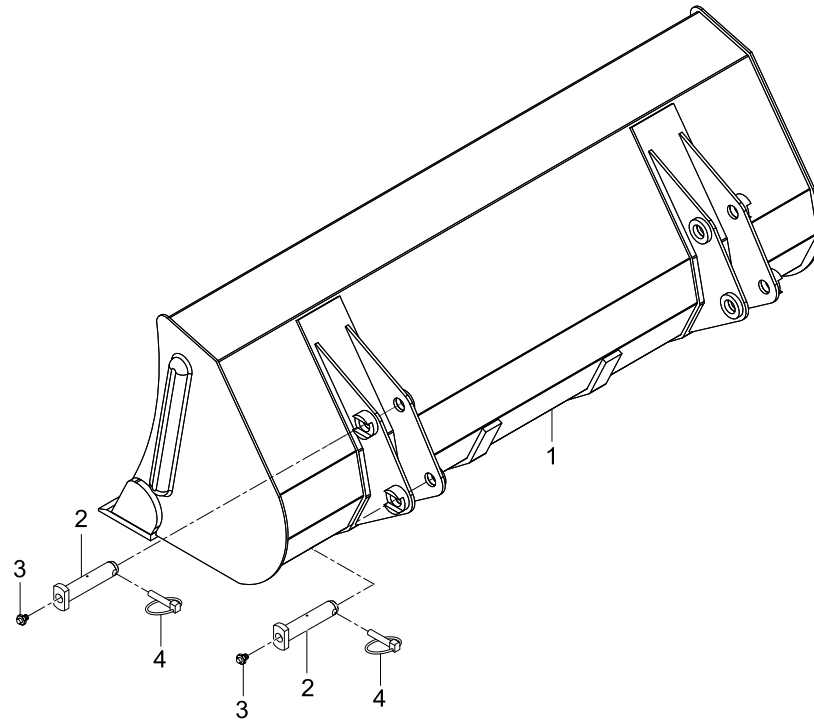

130OD01A

REF. NO	PART. NO	DESCRIPTION	QTY	I.C	REMARK
	LP11-0100-P	Pin Kit, All Pins & Ring Pins	1		
1	LP10-0100	Bucket Ass'y, 60	1	←	
1	LTS17-24300-02	Bucket Ass'y, 60	1	↪	
2	CK11-0105	Pivot Pin (hole), ø25-117L	4		
3	4001-0001	Greese Nipple, PT 1/8"	4		
4	1008-1001	Linch Pin, ø10	4		



13.3 QUICK ATTACHMENT

UPDATED(09.29.2008)

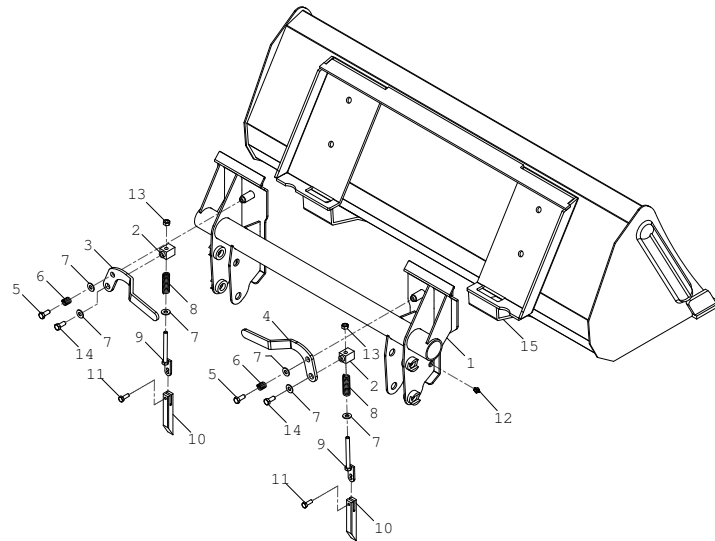

13.4 FRONT GRILL ASSEMBLY (Optional)

UPDATED(03.31.2009)

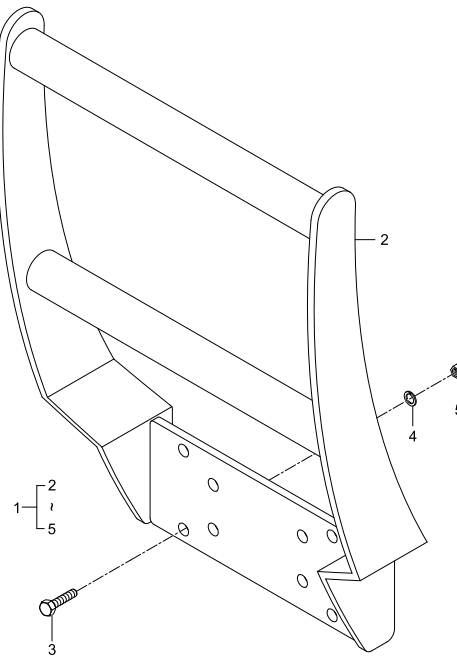

1300D02B

PART ILLUSTRATIONS 13-9

REF. NO	PART. NO	DESCRIPTION	QTY	I.C	REMARK
1	CK15-0100-P	Grill Kit(No 2~6)	1		
2	CK15-0100	Front Grill Ass'y	1		
3	1001-1267	Hex Head Bolt, M12-1.75P 35L	4	↖	
3	10191-M1205-40	Hex Head Bolt, M12-1.75P 40L	4		
4	1003-0012	Spring Washer, ø12	4		
5	1002-1262	Hex Head Nut, M12-1.75P	4		



13.5 BEARING BOX ASSEMBLY

UPDATED(02.06.2007)

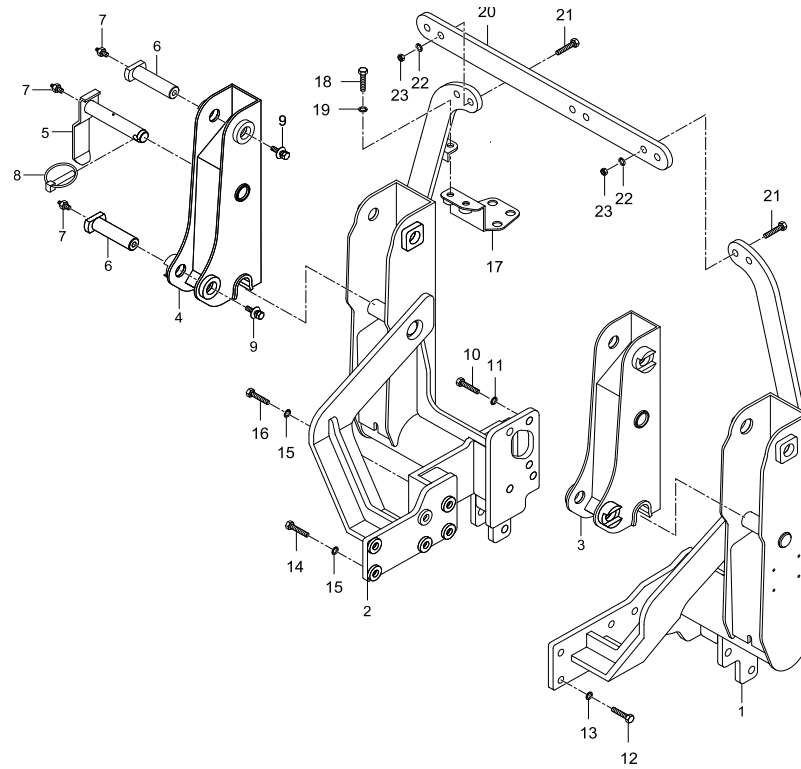

PART ILLUSTRATIONS 13-11

REF. NO	PART. NO	DESCRIPTION	QTY	I.C	REMARK
1	LP02-0100L	Bearing Box LH	1	←	
1	LP02-0100L-A	Bearing Box LH	1	←	40924001~
1	LP02-0100L-A01	Bearing Box LH	1	←	06.09.03~
2	LP02-0100R	Bearing Box RH	1		
3	LP03-0100L	Inner Bearing Box LH	1		
4	LP03-0100R	Inner Bearing Box RH	1		
5	CK11-0102	Latch Pin(Hole), ø25-130L	2	←	WRONG NUMBER
5	CK11-0100	Latch Pin(Hole), ø25-140L	2	←	
6	CK11-0103	Pivot Pin(Bolt), ø25-95L	4		
7	4001-0001	Greese Nipple, PT 1/8"	6		
8	1008-1001	Linch Pin, ø10	2		
9	1001-1054	Hex Head Bolt, M10-1.5P-20	4	←	
9	1010S-M1004-20	Sem`s Bolt, M10-1.5P 20L	4	←	
10	1001-1456	Hex Head Bolt, M14-1.5P-30L	10		
11	1003-0014	Spring Washer, ø14	10		
12	1001-125B	Hex Head Bolt, M12-1.25P-55L	6	←	
12	1001-1236	Hex Head Bolt, M12-1.25P-30L	6	←	40924001~
13	1003-0012	Spring Washer, ø12	6		
14	1001-1257	Hex Head Bolt, M12-1.25P-35L	5		
15	1003-0012	Spring Washer, ø12	6		
16	1001-125F	Hex Head Bolt, M12-1.25P-80L	1		
17	CK02-0117	Attach Fitting Flange	1		
18	1000-1055	Hex Head Bolt, M10-1.5P-25L	2		
19	1003-1010	Spring Washer, ø10	2		
20	LP03-0109	Over Cross Bar	1		

13.5 BEARING BOX ASSEMBLY

UPDATED(02.06.2007)

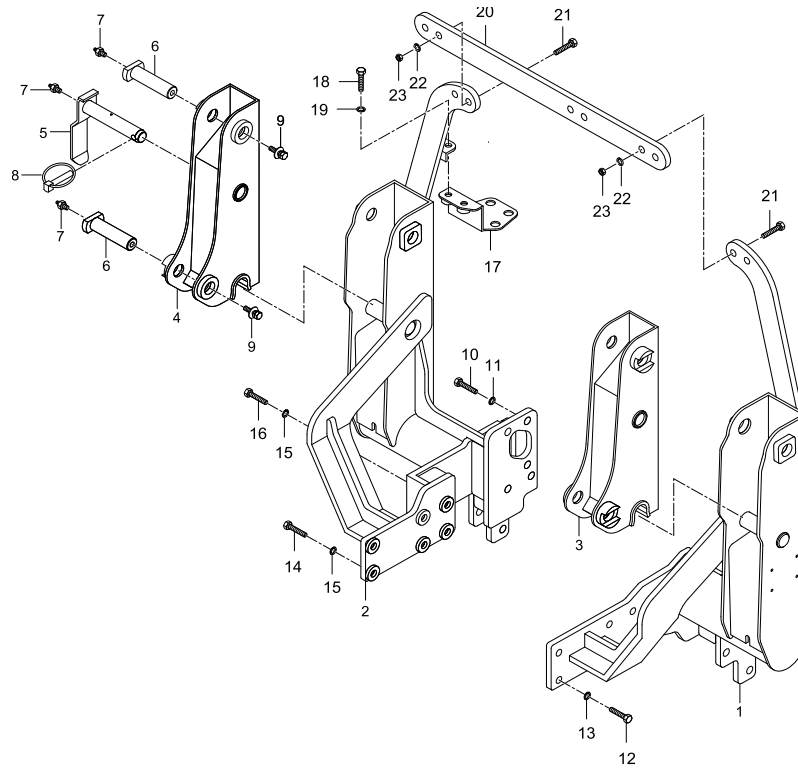

REF. NO	PART. NO	DESCRIPTION	QTY	I.C	REMARK
21	1001-1269	Hex Head Bolt, M12-1.75P-45L	4		
22	1003-0012	Spring Washer, ø12	4		
23	1002-1262	Hex Head Nut, M12-1.75P	4		



13.6 BOOM ASSEMBLY

UPDATED(03.31.2009)

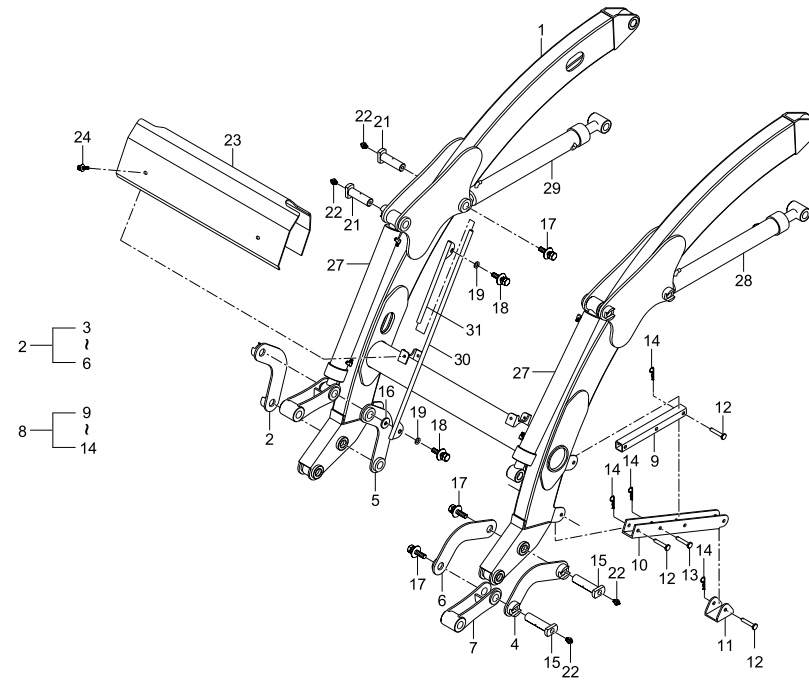

PART ILLUSTRATIONS 13-15

REF. NO	PART. NO	DESCRIPTION	QTY	I.C	REMARK
1	LP05-0100	Boom Ass'y	1	←	
1	LP05-0101-01	Boom Ass'y	1	┌	60907001~
1	LP05-0100-02	Boom Ass'y	1	└	06.11.16~
2	CK06-0100-P	Boom Linkage Kit(No 3~6)	1		
3	CK06-0200R	Boom Linkage Ass'y RH, Outer	1		
4	CK06-0200L	Boom Linkage Ass'y LH, Outer	1		
5	CK06-0100R	Boom Linkage Ass'y RH, Inner	1		
6	CK06-0100L	Boom Linkage Ass'y LH, Inner	1		
7	CK07-0100	Bucket Linkage Ass'y	2	←	
7	CK07-0100-A	Bucket Linkage Ass'y	2	┌	
8	LP09-0100-P	Parking Leg Kit(No 9~14)	2		
9	CK09-0101	Leg Fixer, 30*30 3.2T	2		
10	LP07-0100	Parking Leg, 4.5T	2		
11	CK09-0105	Parking Foot, 4.5T	2		
12	CK09-0106	Long Pivot Pin(Hole) ø10	6		
13	CK09-0108	Short Pivot Pin(Hole) ø10	2		
14	1008-2002	R-Pin, ø3	8		
15	CK11-0103	Pivot Pin(Bolt), ø25-95L	4		
16	CK11-0106	Flat Washer	2		Decreased 10 => 2
18	1001-1054	Hex Head Bolt, M10-1.5P-20L	6	←	
18	1012S-M1004-20	Sem`s Bolt, M10-1.5P-20L	6	┌	
19	1001-1056	Hex Head Bolt, M10-1.5P-30L	2	←	
19	1012S-M1004-30	Sem`s Bolt, M10-1.5P-30L	2	┌	
20	LP09-0103	Bushing, 6T	2		
21	CK11-0104	Pivot Pin(Bolt), ø25-82L	4		

13.6 BOOM ASSEMBLY

UPDATED(03.31.2009)

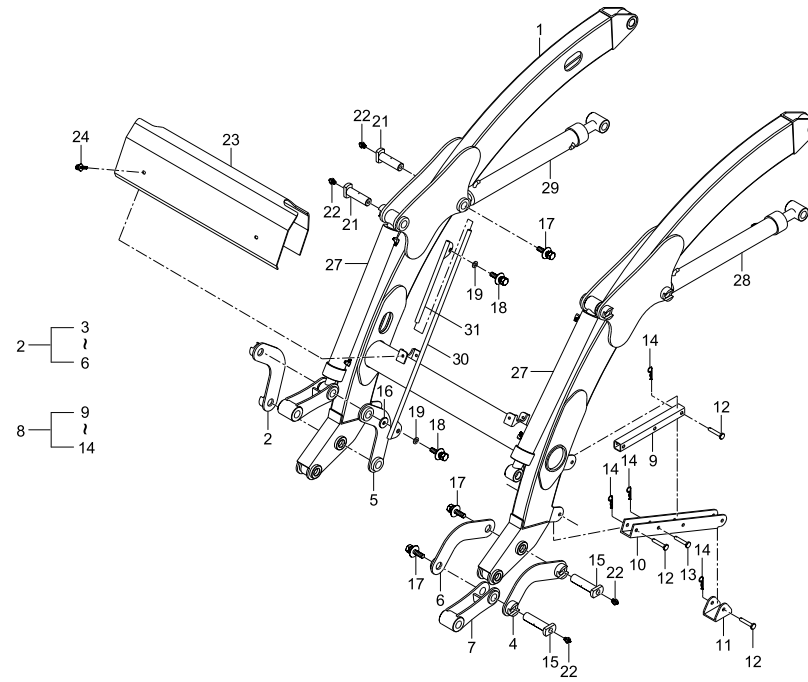

13.7 BOOM HOSE FITTING ASSEMBLY

UPDATED(02.06.2007)

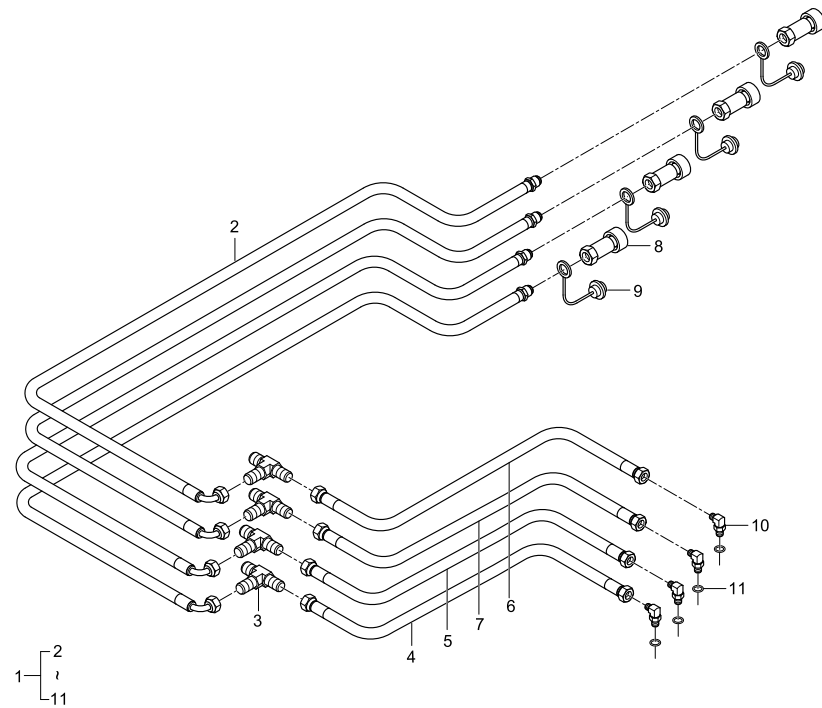

13.8 IN-OUT HOSE FITTING ASSEMBLY

UPDATED(02.06.2007)

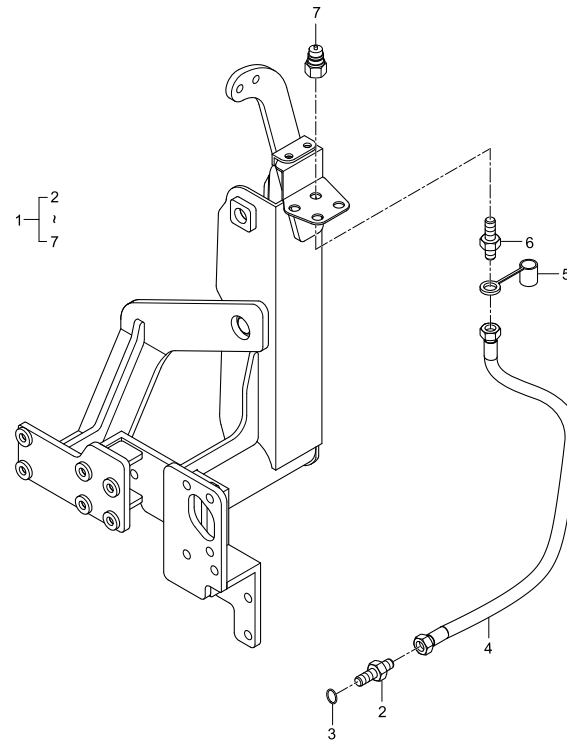

PART ILLUSTRATIONS 13-21

REF. NO	PART. NO	DESCRIPTION	QTY	I.C	REMARK
1	LP12-0400-P	Attach In-Out Hose Fitting Kit(No 2~7)	1		
2	6004-0101	Adapter, 1/2-20 UNF X 9/16-18UNF, O-Ring	4		
3	5003-1111	O-Ring, AS568-906	4		
4	LP12-0400	Hyd. Hose (Control), 454(1/4")-4(1/4") 870L	4		
5	8044R-03300	Dust Cap, 3/8, Red	1		
5	8044Y-03300	Dust Cap, 3/8, Yellow	1		
5	8044B-03300	Dust Cap, 3/8, Blue	1		
5	8044W-03300	Dust Cap, 3/8, White	1		
6	6003-0202	Adapter, PT3/8" X 1/2 - 20UNF	4		
7	0001-1002	Quick Coupler(male), 3/8"	4		



13.9 BOOM CYLINDER ASSEMBLY

UPDATED(02.06.2007)

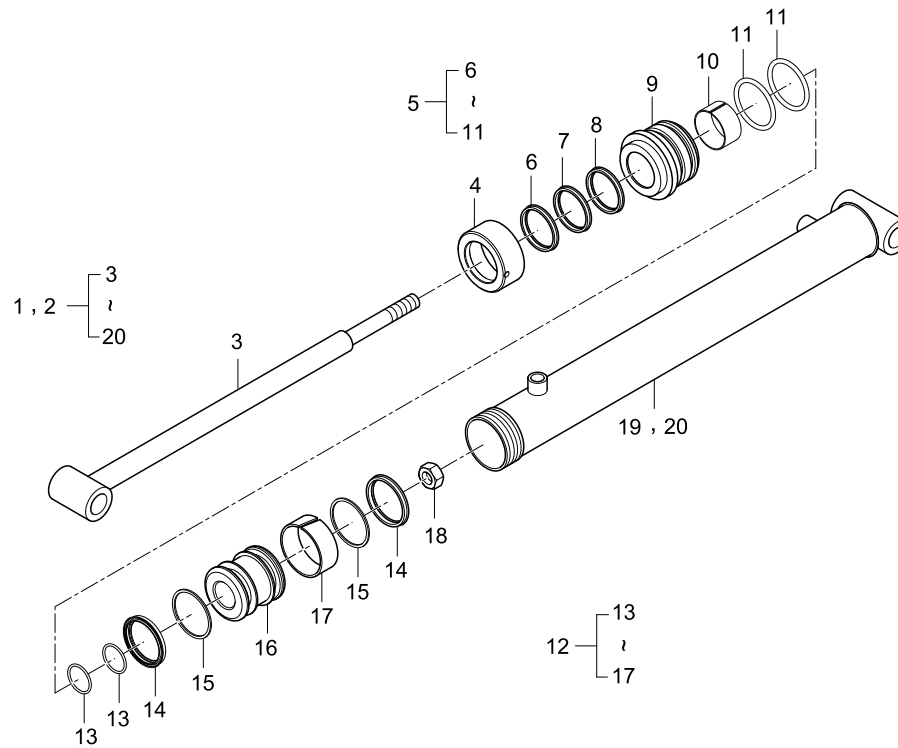

PART ILLUSTRATIONS 13-23

REF. NO	PART. NO	DESCRIPTION	QTY	I.C	REMARK
1	LP06-0100L	Boom Cylinder Ass'y LH(No 3~20)	1	←	50813101~
1	LP06-0100L-A	Boom Cylinder Ass'y LH(No 3~20)	1	↵	50915001~
2	LP06-0100R	Boom Cylinder Ass'y RH(No 3~20)	1	←	50813101~
2	LP06-0100R-A	Boom Cylinder Ass'y RH(No 3~20)	1	↵	50915001~
3	LP06-2101	Rod Ass'y, ø30	2		
4	CK08-2102	Cover	2		
5	CK08-0100-P	Seal Kit, head(No 6~11)	2		
6	CK08-2103	Dust Seal, 30/38/6.5	2		
7	CK08-2104	Retainer (Urethane), 30/40/5	2		
8	CK08-2105	Retainer (Urethane), 30/40/6	2		
9	CK08-2106	Head	2		
10	CK08-2107	Dry Bearing,30/30	2		
11	CK08-2108	O-Ring, 1BG40	4		
12	CK08-0200-P	Seal Kit, Piston(No 13~17)	2		
13	CK08-2109	O-Ring, 1BG23	4		
14	CK08-2110	Retainer, 35/45/6	4		
15	CK08-2111	Backup Ring, 35/45/3	4		
16	CK08-2112	Piston	2		
17	CK08-2113	Packing Bush, 40/45/15	2		
18	CK08-2114-A	Hex Head Nut, 3/4"-16	2		
19	LP06-2102L	Tube Ass'y LH	1	←	50813101~
19	LP06-2102L-A	Tube Ass'y LH	1	↵	50915001~
20	LP06-2102R	Tube Ass'y RH	1	←	50813101~
20	LP06-2102R-A	Tube Ass'y RH	1	↵	50915001~

13.10 BUCKET CYLINDER ASSEMBLY

UPDATED(02.06.2007)

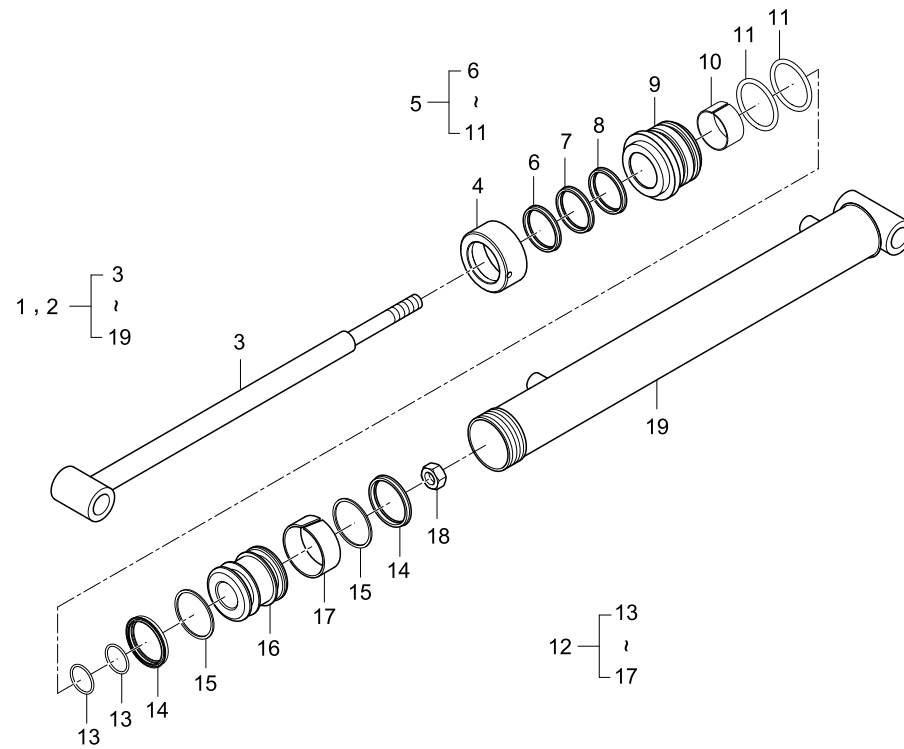

PART ILLUSTRATIONS 13-25

REF.NO	PART.NO	DESCRIPTION	QTY	I.C	REMARK
1	CK08-0100L	Bucket Cylinder Ass'y LH(No 3~19)	1	←	~50813101
1	CK08-0100L-A	Bucket Cylinder Ass'y LH(No 3~19)	1	↙	50915001~
2	CK08-0100R	Bucket Cylinder Ass'y RH(No 3~19)	1	←	~50813101
2	CK08-0100R-A	Bucket Cylinder Ass'y RH(No 3~19)	1	↙	50915001~
3	CK08-1101	Rod Ass'y, ø30	2	←	
3	CK08-1101-A	Rod Ass'y, ø30	2	↙	40510001~
4	CK08-1102	Cover	2		
5	CK08-0100-P	Seal Kit, head(No 6~11)	2		
6	CK08-1103	Dust Seal, 30/38/6.5	2		
7	CK08-1104	Retainer (Urethane), 30/40/5	2		
8	CK08-1105	Retainer (Urethane), 30/40/6	2		
9	CK08-1106	Head	2		
10	CK08-1107	Dry Bearing, 30/30	2		
11	CK08-1108	O-Ring, 1BG40	4		
12	CK08-0200-P	Seal Kit, Piston(No 13~17)	2		
13	CK08-1109	O-Ring, 1BG23	4		
14	CK08-1110	Retainer, 35/45/6	4		
15	CK08-1111	Backup Ring, 35/45/3	4		
16	CK08-1112	Piston	2		
17	CK08-1113	Packing Bush, 40/45/15	2		
18	CK08-1114	Lock Nut, 3/4"-16	2	←	
18	CK08-1114-A	Hex Head Nut, 3/4"-16	2	↙	40510001~
19	CK08-1115	Tube Ass'y	2		

13.10 DECALS

CAUTION

- Read and refer to the Tractor Operation Manual or Decals on the Tractor, and Loader Decals on as shown.

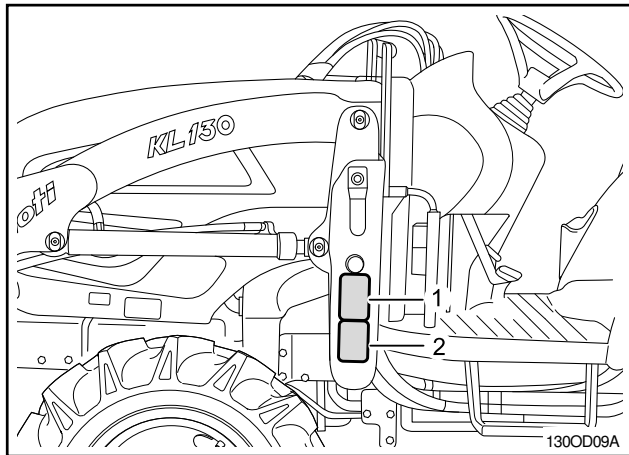

(1) CK12-5001

(2) CK12-3001

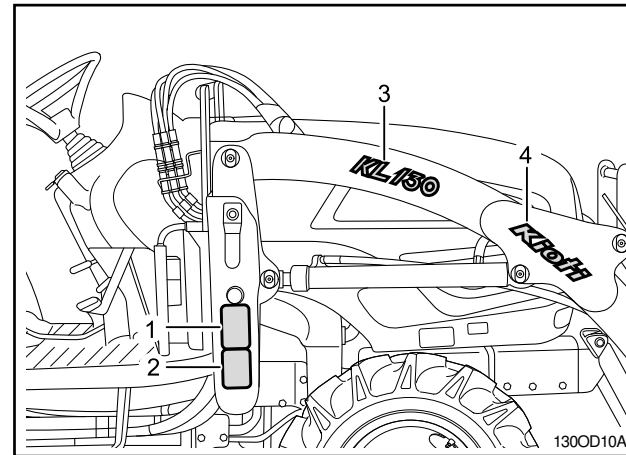

(1) CK12-3002

(2) CK12-3003

(3) LP30-5002

(4) CK12-3004

Refer to category "Safety decals"



14. LOADER INSTALLATION



LOADER INSTALLATION

CAUTION

- See your Loader Operator's manual for Safety Precautions and Tractor Preparations.

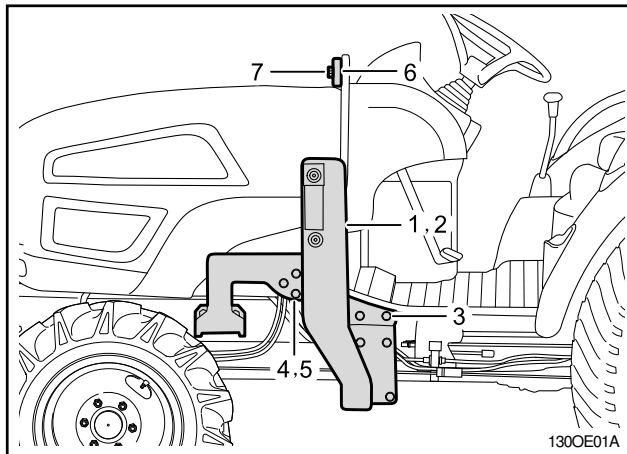

Position tractor on hard level surface.

Release loader, bucket and mount kit box from pallet.

Install Bearing Box LH and Bearing Box RH.

- 1 Bearing Box LH - 1EA
- 2 Bearing Box RH - 1EA
- 3 Hex Head Bolt M14X1.5PX30L - 10EA
Spring Washer \varnothing 14 - 10EA
- 4 Hex Head Bolt M12X1.25PX30L - 6EA(LH)
Spring Washer \varnothing 12 - 6EA
- 5 Hex Head Bolt M12X1.25PX35L - 5EA(RH)
Hex Head Bolt M12X1.25PX80L - 1EA
Spring Washer \varnothing 12 - 6EA

Install Over Cross Bar.

- 6 Overcross Bar - 1EA
- 7 Hex Head Bolt M12X1.75PX45L - 4EA
Hex Head Nut M12X1.75P - 4EA
Spring Washer \varnothing 12 - 4EA

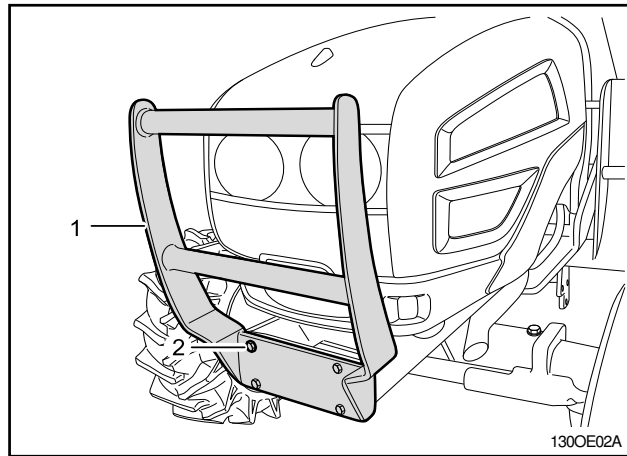

Install Front Grill (Optional)

- 1 Front Grill - 1EA
- 2 Hex Head Bolt M12X1.75Px40L - 4EA
- Spring Washer ϕ 12 - 4EA
- Hex Head Nut M12X1.75P - 4EA

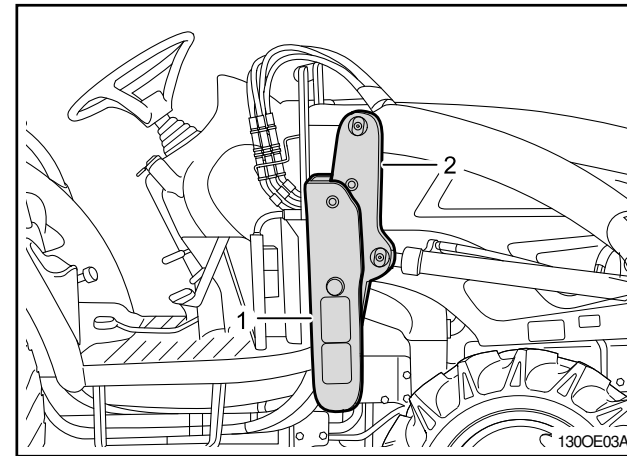

(1) Bearing Inner Box (2) Bearing Box

Install Boom Ass'y

Hang the groove on the pin located on outer bearing box.

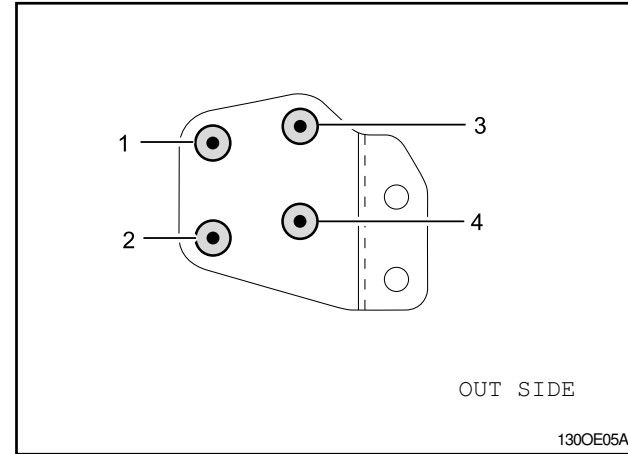
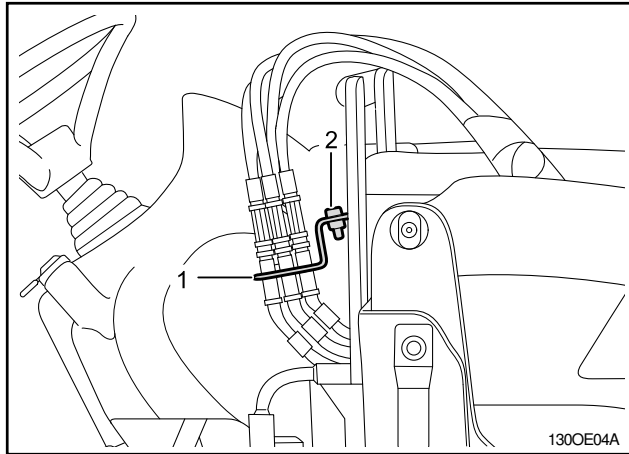

- (1) Red
- (2) Blue
- (3) White
- (4) Yellow

Install Attach Fitting Flange.

W/Quick Coupler (Male)

1 Attach Fitting Flange

W/Quick Coupler(Male) -1SET

2 Hex Head Bolt

M10X1.5PX25L -2EA

Spring washer \varnothing 10 - 2EA

Install the hydraulic hose matching color code rings as shown on the diagram below.

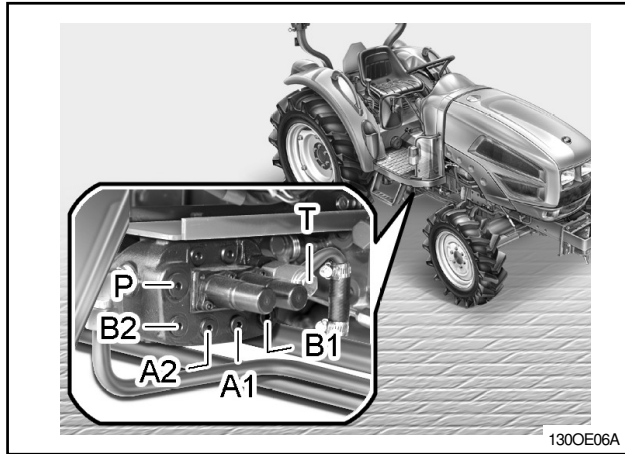

(1) Valve Block

(2) Hydraulic Hose

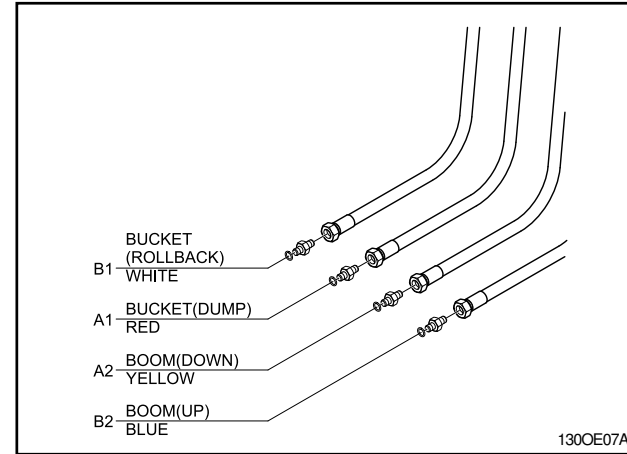

Fit the hydraulic hoses as shown in the diagram below.

3 Adapter w/o - Ring - 4Sets

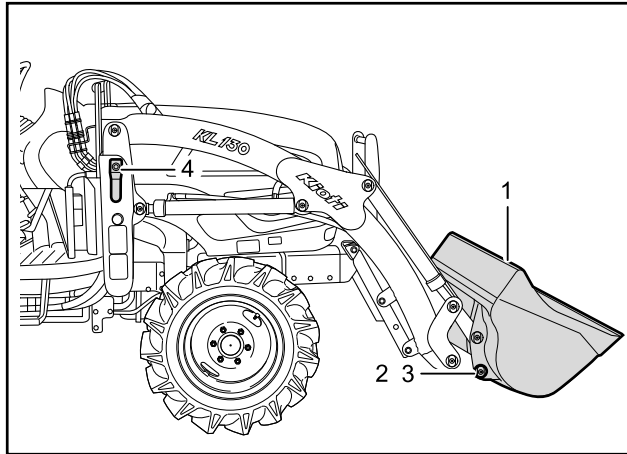

Install Latch pin

4 Latch pin W/Linch Pin - 2Sets

Install the Bucket Ass'y

1 Bucket Ass'y - 1Sets

2 Pivot Pin (Hole) - 4EA

3 Linch Pin - 4EA

Grease every fitting.

See page 9-3 for the grease chart.

Hydr. oil level check.

- Lower the boom on the ground and retract the bucket cylinder.
- Add the hydraulic oil up to the "Full" mark on the oil gauge.
- Specification of oil: Refer to the tractor manual.

In order to check the leakage of hydraulic oil. please operate the Loader 5 times or more with carefully.



15. INDEX 1



KL 130

PART NO	PAGE	PART NO	PAGE	PART NO	PAGE
0001-1001	13-19	10121-M1205-35	13-7	8044Y-03300	13-21
0001-1002	13-21	1012S-M0803-20	13-17	CK02-0117	13-11
1000-0834	13-17	1012S-M1004-20	13-11	CK05-0103	13-15
1000-1055	13-11	1012S-M1004-20	13-15	CK05-0103-01	13-15
1001-1054	13-11	1012S-M1004-30	13-15	CK06-0100L	13-15
1001-1054	13-15	10191-M1205-40	13-9	CK06-0100-P	13-15
1001-1056	13-15	1021N-M1205	13-7	CK06-0100R	13-15
1001-1236	13-11	10321-M1200	13-7	CK06-0200L	13-15
1001-1257	13-11	14213-21026	13-7	CK06-0200R	13-15
1001-125B	13-11	14213-23110	13-7	CK07-0100	13-15
1001-125F	13-11	4001-0001	13-11	CK07-0100-A	13-15
1001-1267	13-9	4001-0001	13-15	CK08-0100	13-17
1001-1269	13-11	4001-0001	13-5	CK08-0100-A	13-17
1001-1456	13-11	5003-1011	13-21	CK08-0100L	13-25
1002-1262	13-9	5004-0014	13-19	CK08-0100L-A	13-25
1002-1262	13-13	6003-0202	13-21	CK08-0100-P	13-23
1003-0012	13-9	6003-0502	13-19	CK08-0100-P	13-25
1003-0012	13-11	6004-0101	13-21	CK08-0100R	13-25
1003-0012	13-11	6004-0202	13-19	CK08-0100R-A	13-25
1003-0012	13-13	802G0-T1900	13-7	CK08-0200-P	13-23
1003-0014	13-11	8043B-03300	13-19	CK08-0200-P	13-25
1003-1010	13-11	8043R-03300	13-19	CK08-1101	13-25
1008-1001	13-11	8043W-03300	13-19	CK08-1101-A	13-25
1008-1001	13-5	8043Y-03300	13-19	CK08-1102	13-25
1008-1001	13-7	8044B-03300	13-21	CK08-1103	13-25
1008-2002	13-15	8044R-03300	13-21	CK08-1104	13-25
1012S-M1205-20	13-7	8044W-03300	13-21	CK08-1105	13-25

PART. NO INDEX

PART NO	PAGE	PART NO	PAGE	PART NO	PAGE
CK08-1106	13-25	CK09-0108	13-15	LP05-0101	13-15
CK08-1107	13-25	CK11-0100	13-11	LP06-0100L	13-17
CK08-1108	13-25	CK11-0102	13-11	LP06-0100L	13-23
CK08-1109	13-25	CK11-0103	13-11	LP06-0100L-A	13-17
CK08-1110	13-25	CK11-0103	13-15	LP06-0100L-A	13-23
CK08-1111	13-25	CK11-0104	13-15	LP06-0100R	13-17
CK08-1112	13-25	CK11-0105	13-5	LP06-0100R	13-23
CK08-1113	13-25	CK11-0105	13-7	LP06-0100R-A	13-17
CK08-1114	13-25	CK11-0106	13-15	LP06-0100R-A	13-23
CK08-1114-A	13-25	CK12-0400	13-19	LP06-2101	13-23
CK08-1115L	13-25	CK12-0500	13-19	LP06-2102L	13-21
CK08-2102	13-23	CK15-0100	13-9	LP06-2102L-A	13-21
CK08-2103	13-23	CK15-0100-P	13-9	LP06-2102R	13-23
CK08-2104	13-23	FTE01-71200	13-17	LP06-2102R-A	13-23
CK08-2105	13-23	FTE01-72100	13-17	LP07-0100	13-15
CK08-2106	13-23	KLD20-42100-03	13-7	LP08-0100	13-17
CK08-2107	13-23	KLD20-42211-01	13-7	LP08-0200	13-17
CK08-2108	13-23	KLD20-42231	13-7	LP09-0100-P	13-15
CK08-2109	13-23	KLD20-42232	13-7	LP09-0103	13-15
CK08-2110	13-23	LP02-0100L	13-11	LP10-0100	13-5
CK08-2111	13-23	LP02-0100L-A	13-11	LP11-0100-P	13-5
CK08-2112	13-23	LP02-0100R	13-11	LP12-0100	13-19
CK08-2113	13-23	LP03-0100L	13-11	LP12-0100-P	13-19
CK08-2114-A	13-23	LP03-0100R	13-11	LP12-0200	13-19
CK09-0101	13-15	LP03-0109	13-11	LP12-0200-P	13-21
CK09-0105	13-15	LP05-0100	13-15	LP12-0300	13-19
CK09-0106	13-15	LP05-0100-02	13-15	LP12-0400	13-21

KL 130

PART NO	PAGE	PART NO	PAGE	PART NO	PAGE
LP12-0500	13-19				
LTS17-24300-02	13-5				
LTS19-22450-03	13-7				
LTS21-42000-05	13-7				
LTS21-42220-01	13-7				
LTS21-42231-01	13-7				
LTS21-44802	13-7				



15. INDEX 2



PART NAME	PAGE	PART NAME	PAGE
A		Boom Cylinder Ass'y RH, ø45X550-(ST350)	13-17
Adapter, 1/2-20 UNF X 9/16-18UNF, O-Ring	13-21	Boom Linkage Ass'y LH, Inner	13-15
Adapter, PT3/8" X 1/2 - 20UNF	13-21	Boom Linkage Ass'y LH, Outer	13-15
Attach Boom Hose Kit(No 2~11)	13-19	Boom Linkage Ass'y RH, Inner	13-15
Attach Fitting Flange	13-11	Boom Linkage Ass'y RH, Outer	13-15
Attach Pin(Hole), ø25-130L	13-11	Boom Linkage Kit(No 3~6)	13-15
Attach Pin(Hole), ø25-140L	13-11	Bucket Ass'y, 60	13-5
		Bucket Ass'y, 60	13-5
B		Bucket Cylinder Ass'y LH(No 3~19)	13-25
Backup Ring, 35/45/3	13-23	Bucket Cylinder Ass'y LH(No 3~19)	13-25
Backup Ring, 35/45/3	13-25	Bucket Cylinder Ass'y RH(No 3~19)	13-25
BAR-LINK	13-7	Bucket Cylinder Ass'y RH(No 3~19)	13-25
Bearing Box LH	13-11	Bucket Cylinder Ass'y, ø45X589-(ST330)	13-17
Bearing Box LH	13-11	Bucket Cylinder Ass'y, ø45X589-(ST330)	13-17
Bearing Box RH	13-11	Bucket Linkage Ass'y	13-15
Boom Ass'y	13-15	Bucket Linkage Ass'y	13-15
Boom Ass'y	13-15	BUCKET W.A	13-7
Boom Ass'y	13-15	Bushing, 6T	13-15
Boom Cover, 3.2T	13-15		
Boom Cover, 3.2T	13-15	C	
Boom Cylinder Ass'y LH(No 3~20)	13-23	Cover	13-23
Boom Cylinder Ass'y LH(No 3~20)	13-23	Cover	13-25
Boom Cylinder Ass'y LH, ø45X550-(ST350)	13-17		
Boom Cylinder Ass'y LH, ø45X550-(ST350)	13-17	D	
Boom Cylinder Ass'y RH(No 3~20)	13-23	Dry Bearing, 30/30	13-25
Boom Cylinder Ass'y RH(No 3~20)	13-23	Dry Bearing,30/30	13-23
Boom Cylinder Ass'y RH, ø45X550-(ST350)	13-17	Dust Cap, 3/8, Blue	13-21

PART NAME INDEX

PART NAME	PAGE	PART NAME	PAGE
Dust Cap, 3/8, Red	13-21	Head	13-23
Dust Cap, 3/8, White	13-21	Head	13-25
Dust Cap, 3/8, Yellow	13-21	Hex Head Bolt, M10-1.5P 20L	13-11
Dust Plug, 3/8, Blue	13-19	Hex Head Bolt, M10-1.5P-20L	13-15
Dust Plug, 3/8, Red	13-19	Hex Head Bolt, M10-1.5P-25L	13-11
Dust Plug, 3/8, White	13-19	Hex Head Bolt, M10-1.5P-30L	13-15
Dust Plug, 3/8, Yellow	13-19	Hex Head Bolt, M12-1.25P-30L	13-11
Dust Seal, 30/38/6.5	13-23	Hex Head Bolt, M12-1.25P-35L	13-11
Dust Seal, 30/38/6.5	13-25	Hex Head Bolt, M12-1.25P-55L	13-11
E		Hex Head Bolt, M12-1.25P-80L	13-11
Elbow, O-Ring 90° , PF(1/4)X901(1/4)	13-19	Hex Head Bolt, M12-1.75P 35L	13-9
F	13-15	Hex Head Bolt, M12-1.75P 40L	13-9
Flat Washer	13-9	Hex Head Bolt, M12-1.75P-40L	13-11
Front Grill Ass'y		Hex Head Bolt, M14-1.5P-30L	13-11
G		Hex Head Bolt, M8-1.25P-20L	13-17
GREASE NIPPLE, PT 1/8	13-7	Hex Head Nut, 3/4"-16	13-23
Greese Nipple, PT 1/8 "	13-5	Hex Head Nut, 3/4"-16	13-25
Greese Nipple, PT 1/8"	13-11	Hex Head Nut, M12-1.75P	13-9
Greese Nipple, PT 1/8"	13-15	Hex Head Nut, M12-1.75P	13-13
Grill Kit(No 2~6)	13-9	HEX.BOLT, M12-1.75P 20L	13-7
H		HEX.BOLT, M12-1.75P 35L	13-7
HANDLE-LH.	13-7	HEX.NUT, M12	13-7
HANDLE-RH.	13-7	Hyd Hose(Main), 904(1/4")X1(PT3/8") 2300L	13-19
		Hyd. Hose (Boom Down), 4(1/4")-4(1/4") 1300L	13-19
		Hyd. Hose (Boom Lift), 4(1/4")-4(1/4") 1000L	13-19
		Hyd. Hose (Boom Lift), 4(1/4")-4(1/4") 1150L	13-19
		Hyd. Hose (Bucket Dump), 4(1/4")-4(1/4") 650L	13-19

KL 130

PART NAME	PAGE	PART NAME	PAGE
H		Over Cross Bar	13-11
Hyd. Hose (Bucket Rollback), 4(1/4")X4(1/4") 750L	13-19	P	
Hyd. Hose (Control), 454(1/4")-4(1/4") 870L	13-21	Packing Bush, 40/45/15	13-23
I		Packing Bush, 40/45/15	13-25
Inner Box LH	13-11	Parking Foot, 4.5T	13-15
Inner Box RH	13-11	Parking Leg Kit(No 9~14)	13-15
In-Out Hose Fitting Kit(No 2~7)	13-21	Parking Leg, 4.5T	13-15
L		Pin Kit, All Pins & Ring Pins	13-5
Leg Fixer, 30*30 3.2T	13-15	PIN, 172.5L	13-7
Level Indicator Rod	13-17	PIN-LOCK	13-7
Level Indicator Rod W.A.	13-17	Piston	13-23
Level Indicator Tube W.A.	13-17	Piston	13-25
Level Indicator Tube W.A.	13-17	Pivot Pin (hole), ø25-117L	13-5
Linch Pin, ø10	13-5	Pivot Pin (hole), ø25-117L	13-7
Linch Pin, ø10	13-7	Pivot Pin(Bolt), ø25-82L	13-15
Lock Nut, 3/4"-16	13-25	Pivot Pin(Bolt), ø25-95L	13-11
Long Pivot Pin(Hole), ø10	13-15	Pivot Pin(Bolt), ø25-95L	13-15
O		Q	
O-Ring, 1/4	13-19	QUICK ATTA. ASS'Y	13-7
O-Ring, 1BG23	13-23	QUICK ATTA. W.A	13-7
O-Ring, 1BG23	13-25	Quick Coupler(Female), PT3/8"	13-19
O-Ring, 1BG40	13-23	Quick Coupler(male), PT3/8"	13-21
O-Ring, 1BG40	13-25	R	
O-Ring, AS568-906	13-21	Retainer (Urethane), 30/40/5	13-23

PART NAME INDEX

PART NAME	PAGE	PART NAME	PAGE
Retainer (Urethane), 30/40/5	13-25	Spring Washer, ø12	13-11
Retainer (Urethane), 30/40/6	13-23	Spring Washer, ø12	13-13
Retainer (Urethane), 30/40/6	13-25	Spring Washer, ø14	13-11
Retainer, 35/45/6	13-23	Tee, 1/2 - 20 UNF	13-19
Retainer, 35/45/6	13-25	Tube Ass'y	13-25
Ring Pin, ø10	13-11	Tube Ass'y LH	13-21
Rod Ass'y, ø30	13-23	Tube Ass'y LH	13-21
Rod Ass'y, ø30	13-25	Tube Ass'y RH	13-23
Rod Ass'y, ø30	13-25	Tube Ass'y RH	13-23
R-Pin, ø3	13-15	WASHER-PLAIN, M12	13-7
S			
Seal Kit, head(No 6~11)	13-23		
Seal Kit, head(No 6~11)	13-25		
Seal Kit, Piston(No 13~17)	13-23		
Seal Kit, Piston(No 13~17)	13-25		
Sem's Bolt, M10-1.5P 20L	13-11		
Sem's Bolt, M10-1.5P 20L	13-15		
Sem's Bolt, M10-1.5P 30L	13-15		
Sem's Bolt, M8-1.25P 20L	13-17		
Short Pivot Pin(Hole), ø10	13-15		
SPRING	13-7		
SPRING	13-7		
SPRING PIN, O.D10-25L	13-7		
Spring Washer, ø10	13-11		
Spring Washer, ø12	13-9		
Spring Washer, ø12	13-11		





15. INDEX 3



B

BACKFILLING/BACKGRADING	6-4
BEARING BOXASSEMBLY	13-8
BEARING BOXASSEMBLY	13-10
BOOMASSEMBLY	13-12
BOOMASSEMBLY	13-14
BOOM CYLINDER ASSEMBLY	13-20
BOOM HOSE FITTING ASSEMBLY	13-16
BUCKET ASSEMBLY	13-4
BUCKET CYLINDER ASSEMBLY	13-22
BUCKET CYLINDER ASSEMBLY	13-24

C

CARE OF SAFETY DECALS	2-2
COLD WEATHER OPERATION	6-3
CONTROLLED RATE OF LOADER FUNCTIONS	6-4

D

DECALS	13-26
DIRECTIONAL REFERENCE	13-2
DUMPING BUCKET	6-3

F

FRONT GRILL ASSEMBLY (OPTIONAL)	13-6
FRONT COUNTERWEIGHT	5-3

G

GENERAL INFORMATION	13-2
---------------------------	------

H

HYDRAULIC SYSTEM SCHEMATIC	11-2
----------------------------------	------

I

IN-OUT HOSE FITTING ASSEMBLY	13-18
INTERCHANGEABILITY	13-3
INTRODUCTION	4-2
ILLUSTRATIONS	13-2
INITIAL LOADER OPERATION	6-3
INSTRUCTIONS	13-2

L

LOADER INSTALLATION	14-2
LOADER MOUNTING	8-2
LOADER OPERATION	6-2
LOADER REMOVAL	7-2
LUBRICATION AND MAINTENANCE	9-2
LOADER HYDRAULIC CONTROLS	6-5
LOADER SPECIFICATIONS	3-2
LOADING BUCKET	6-3

P

PARTS ORDER	13-2
PRECAUTIONARY NOTES	6-2

R

ROPS SYSTEM	5-2
REAR COUNTERWEIGHT	5-2

S

SAFETY	1-2
SAFETY PRECAUTIONS	1-2
SAFETY DECALS	2-2
SAFETY DECAL LOCATIONS	2-2
SCRAPING	6-4

T

TORQUE TIGHTENING CHART 1	12-2
TORQUE TIGHTENING CHART 2	12-3
TRACTOR PREPARATION	5-2
TRACTOR TIRES	5-3
TROUBLE SHOOTING	10-2
TIRE INFLATION	5-3
TRACTOR HYDRAULIC SYSTEM	5-2
TRANSPORTING A LOADED BUCKET	6-4

W

WE URGE YOU TO FOLLOW THIS ADVICE:	6-2
WHEEL TREAD SETTINGS	5-3





