

TAE SUNG

OPERATING & SAFETY MANUAL

KL500

Front End Loader

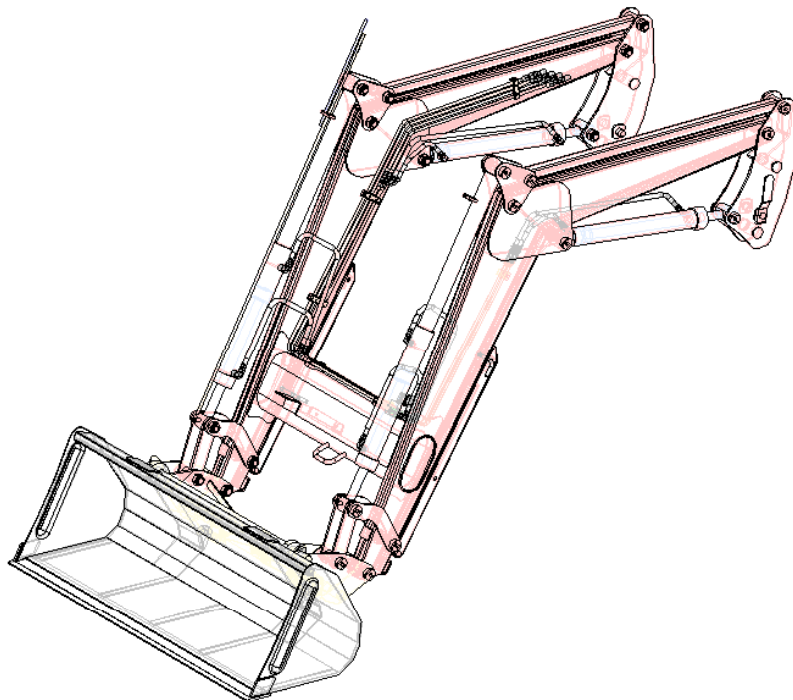

SELF LEVELING TYPE

Parts Catalogue

Table of contents

Introduction – 1

Safety precautions – 2~3

Safety alert symbol – 2

Important safety precautions – 3

Specification – 5

Operation instructions and safety tips – 6~10

Filling the bucket – 6

Lifting the load & Rollback Carrying the load – 7

Carrying the load – 7

Loading from a pile – 8

Dumping the bucket – 8

Back Grading – 8

Digging with bucket – 9

Backfilling – 9

Incorrect loading – 10

Attaching and Detaching loader frame arms – 11~12

Detaching procedure – 11

Attaching procedure – 12

Attaching and Detaching attachments – 13~14

Attaching attachments – 13

Detaching attachments – 14

Lubrication and Maintenance – 14

Part Illustrations – 16~36

Mounting Frame Assembly – 16

Boom Assembly(Self Leveling Device) – 18

Hydraulic Piping(Self Leveling Device) – 20

Quick Attachment – 22

Bucket Assembly – 24

Boom Cylinder Ass'y – 26

Bucket Cylinder Ass'y-LH – 28

Bucket Cylinder Ass'y-RH – 30

Safety Decals – 32

INTRODUCTION

The purpose of this manual is to assist you in maintaining and operating your loader. Read it carefully, it furnishes information and instructions that will help you achieve years of dependable performance. Some information may be general in nature due to unknown and varying conditions. However, through experience and these instructions, you should be able to develop operating procedures suitable to your particular situation.

"Right" and "Left" as used throughout this manual are determined by facing the direction the machine will travel when in use.

The photos, illustrations and data used in this manual are current at the time of printing, but due to possible in-line production changes, your machine may vary slightly in detail. The manufacturer reserves the right to redesign the machine as may be necessary without notification.

Important:

Illustrations used in this manual may not show all safety equipment that is recommended to ensure safe operation of tractor and loader. Refer to the Safety Precautions section of this manual for information concerning safety. consult your dealer for further information.

Serial Number and Location

The serial number is important information about the machine and it may be necessary to know it before obtaining the correct replacement part.

The serial number should be recorded on the Delivery and Registration form and also below for your reference.

Safety Alert Symbol



This Safety Alert Symbol means: **“ATTENTION! BECOME ALERT! YOUR SAFETY IS INVOLVED!”**

This symbol is used to call attention to safety precautions that should be followed by the operator to avoid accidents. When you see this symbol, carefully read the message that follows and heed its advice. Failure to comply with safety precautions could result in death or serious bodily injury.

Safety Signs *Signal Words*

The signal words **DANGER, WARNING, AND CAUTION** are used on the equipment safety signs. These words are intended to alert the viewer to the existence and the degree of hazard seriousness.



This signal word indicates a potentially hazardous situation which, if not avoided, will result in death or serious injury.



This signal word indicates a potentially hazardous situation which, if not avoided, could result in death or serious injury

It may also be used to alert against unsafe practices



This signal word indicates a potentially hazardous situation exist which, if not avoided, may result in minor or moderate injury.

It may also be used to alert against unsafe practices.

IMPORTANT SAFETY PRECAUTIONS

This symbol is used to call attention to safety precautions that should be followed by the operator to avoid accidents. When you see this symbol, carefully read the message that follows and heed its advice. Failure to comply with safety precautions could result in death or serious bodily injury.



In addition to the design and configuration of equipment, hazard control and accident prevention are dependent upon the awareness, concern, prudence and proper training of personnel in the operation, transport, maintenance and storage of equipment. Lack of attention to safety can result in accident, personal injury, reduction of efficiency and worst of all—loss of life. Watch for safety hazards and correct deficiencies promptly. Use the following safety precautions as a general guide to safe operations when using this machine. Additional safety precautions are used throughout this manual for specific operating and maintenance procedures. Read this manual and review the safety precautions often until you know the limitations.

THE LOADER

1. Read the loader operator's manual to learn how to operate your loader safely. Failure to do so could result in serious injury or death and equipment damage.
2. Become familiar with all the machine's controls and all the caution, warning and danger decals affixed to the machine before attempting to start or operate.
3. Improper use of a loader can cause serious injury or death.
4. Do not lift or carry anybody on the loader or in the bucket or attachment.
5. Never allow anyone to get under the loader bucket or reach through the booms when the bucket is raised.
6. Do not walk or work under a raised loader bucket or attachment unless it is securely blocked or held in position
7. Avoid overhead wires and obstacles when loader is raised. Contacting electrical lines can cause electrocution.
8. Make sure all parked loaders on stands are on a hard, level surface.
9. Use a piece of cardboard or wood rather than hands and wear eye protection when searching for hydraulic leaks.
Escaping hydraulic oil under pressure can penetrate skin. If oil is injected into skin, it must be surgically removed within a few hours by a doctor or gangrene may result.
10. Before disconnecting hydraulic lines, relieve all hydraulic pressure.
11. Do not tamper with the relief valve setting. The relief valve is pre-set at the factory. Changing the setting can cause overloading the loader and tractor and serious operator injury may result.
12. Always wear safety goggles when repairing or servicing machine.

SAFETY PRECAUTIONS CONTINUED

13. When servicing or replacing pins in cylinder ends, buckets, etc., always use a brass drift and hammer. Failure to do so could result in injury from flying fragments.
14. Replace damaged or illegible safety decals. See decal page for required decals.
15. Do not modify or alter or permit anyone else to modify or alter the loader, any of its components or any loader function without first consulting your local dealer.

OPERATING THE LOADER

1. It is the loader owner's responsibility to instruct and have a person read operator's manual, safety decals and become familiar with machine controls before allowing them to operate loader.
2. Do not allow children to operate the loader.
3. Before starting or operating the equipment, make a walk around inspection and check for loose or damaged components. Correct any deficiency before starting.
4. Keep the area of operation clear of all persons, particularly small children. The operator should cease operation whenever anyone comes within the operating area.
5. Operate the loader from the "Operator's Seat Only."
6. Exercise caution when operating the loader with a raised loaded bucket.
7. Avoid loose fill, rocks and holes. They can be dangerous for loader operation or movement.
8. Be extra careful when working on inclines.
9. Allow for the loader length when making turns.
10. Stop the loader arms gradually when lowering or lifting.
11. Use caution when handling loose or shift able loads.
12. Carry loader arms at a low position during transport.
13. Lower loader arms, stop engine, and lock brakes before leaving the tractor seat.
14. Operate the loader controls only when properly seated at the controls.
15. Do not use loader for handling large, heavy objects such as logs, oil drums, etc.
16. Handling large, heavy objects is dangerous due to:
 - *Possibility of rolling the tractor over.
 - *Possibility of upending the tractor.
 - *Possibility of the object rolling or sliding down the loader arms onto the operator.

SPECIFICATIONS

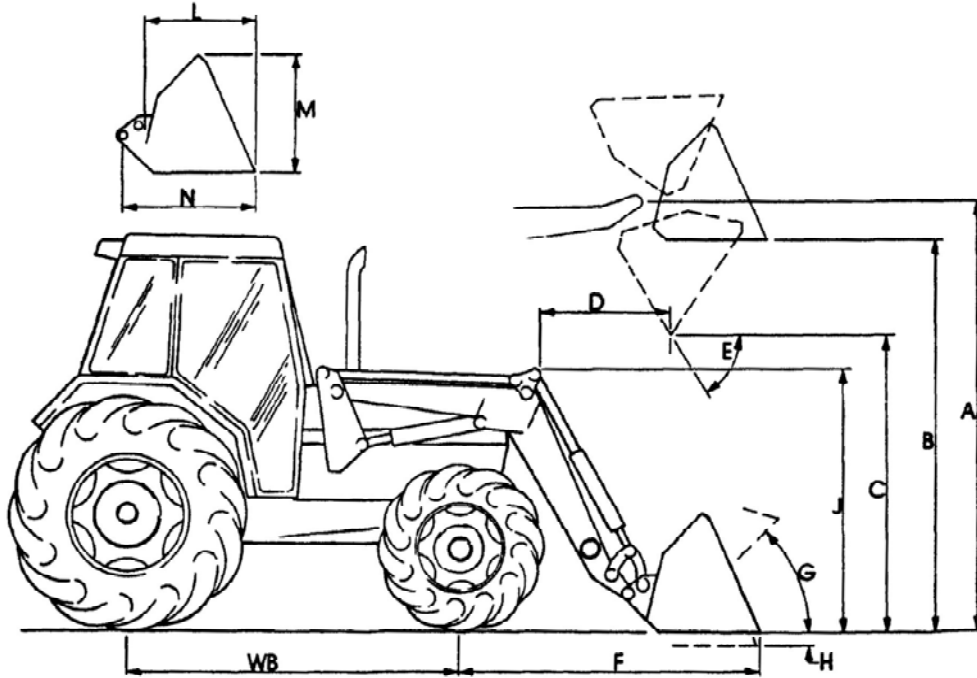

Figure 1 - Dimensional specifications

* Specifications shown are based on ASAE Standards.

* Specifications and design are subject to change without prior notice.

Loader Model : KL500
 Tractor Model : LX480L
 Bucket Leveling : SELF LEVEL TYPE

A.	Maximum lift height to pivot pin	2,754 mm	108.4 "
B.	Maximum lift height under level bucket	2,464 mm	97.0 "
C.	Clearance with bucket dumped	1,922 mm	75.7 "
D.	Reach at maximum lift height	319 mm	12.6 "
E.	Maximum dump angle	58.0 °	58.0 °
F.	Reach with bucket on ground	1,893 mm	74.5 "
G.	Maximum rollback angle	48.0 °	48.0 °
H.	Digging depth	160 mm	6.3 "
J.	Overall height in carry position	1,437 mm	56.6 "
L.	Bucket depth	584 mm	23.0 "
M.	Bucket height	563 mm	22.2 "
N.	Bucket length	798 mm	31.4 "
Lift capacity to maximum height—at pivot pin		1,450 Kgf	3,198 lbs
Breakout force—at pivot pin		2,073 Kgf	4,570 lbs
Bucket width		1,702 mm	67.0 "
Boom cylinder		35x60x700x480ST mm	1.38x2.36x27.56x18.90ST "
Bucket cylinder		35x60x998x332ST mm	1.38x2.36x39.29x13.07ST "

OPERATING INSTRUCTIONS and SAFETY TIPS

Operating Front Wheel Assist Tractor

When operating the loader/tractor unit with front wheel assist engaged, to enable an even transmission loading, it is recommended that a rear linkage counterweight be fitted.

Filling The Bucket

Approach and enter the pile with a level bucket.

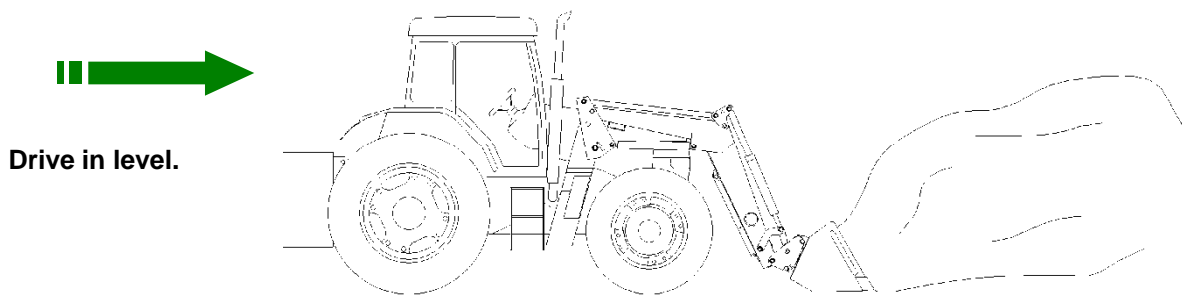

Drive in level.

For optimum performance move the control lever(s) to direct pressure to both the lift and crowd cylinders, effectively lifting and rolling the bucket back.

The combined action of the lift and crowd cylinders increase loading efficiency, whereas a level bucket (throughout the lifting cycle) creates more resistance against bucket lifting and increases the break-out force required.

Correct Method of Filling Bucket.

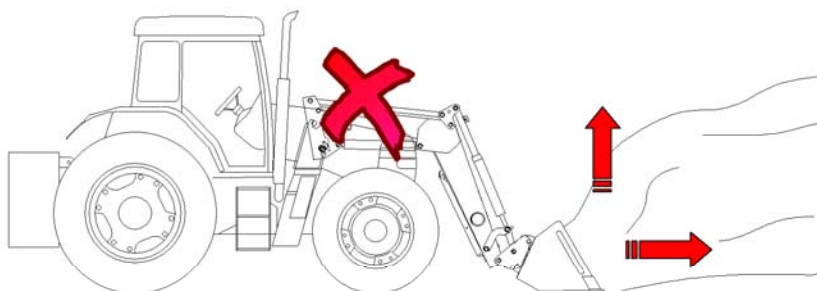
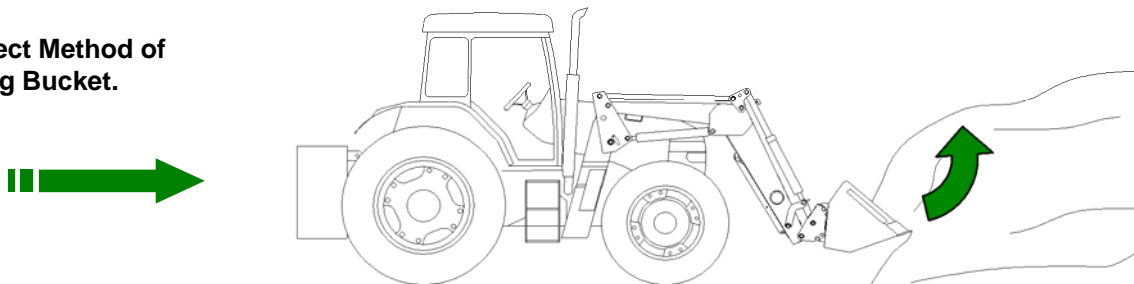

Incorrect Method of Filling Bucket.

NOTE : Overfilling the bucket in heavy or packed material may cause the loader to stall. If loader stalls, back up or reduce the amount of material to be handled.

Lifting the Load & Rollback

DANGER - Avoid serious injury or death from falling objects.

Your Front End Loader is fitted with a Mechanical Level Lift System, when operated correctly you will avoid any chance of rollback.

DO NOT handle round bales unless loader is equipped with an approved bale handling attachment. Otherwise the bale can fall (rollback) onto the operator or bystanders as loader is raised.

Never lift a load while the tractor is in motion. As a competent operator you should travel to the point where load is to be raised, cease all motion, raise the load as required to clear stock pile or vehicle, then travel the final distance with care and load or unload attachment. The same applies when moving away from a stock pile or vehicle, reverse until loader clears obstruction, cease all motion, lower loader to travel height then proceed to reverse away looking in the direction of travel at all times.

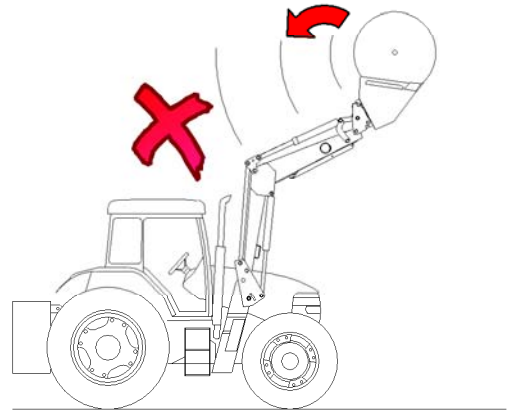

Carrying The Load

For maximum stability and visibility, carry the attachment as low as conditions allow, irrespective of whether the attachment is loaded or empty. When traveling with a load, **do not exceed 8 kph**.

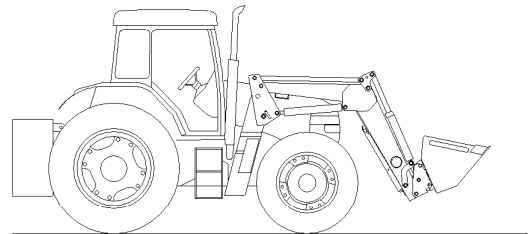

When operating the loader on a hill or slope, maximize tractor stability by keeping the centre of gravity of the attachment as low as possible. Ensure a counterweight is fitted and rear wheel track has been set to the widest practical position. Likewise, in case a wheel drops in a rut when transporting a load, keep the attachment as low as possible to avoid rollover. **Travel slowly.**

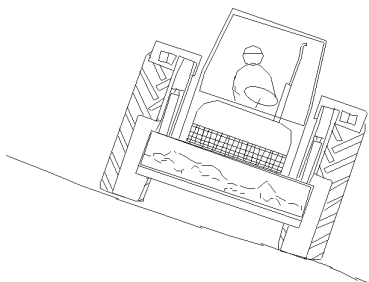

Safe Centre of Gravity of Load

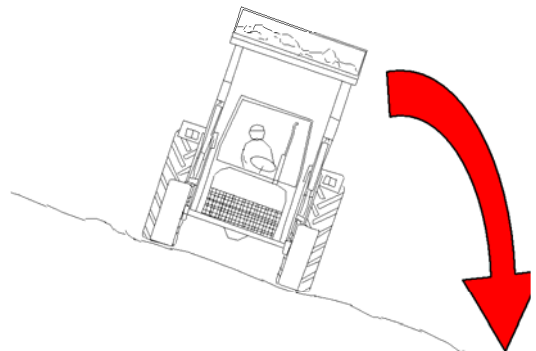

Unsafe High Centre of Gravity of Load

Loading From A Pile

To increase loading efficiency, minimize the angle of turn and length of run between the pile and the vehicle. Always keep the working area clean to maintain a level platform, prevent tyre damage and speed up loading cycle. Carry loaded bucket just above ground and only raise the loader when reaching the vehicle.

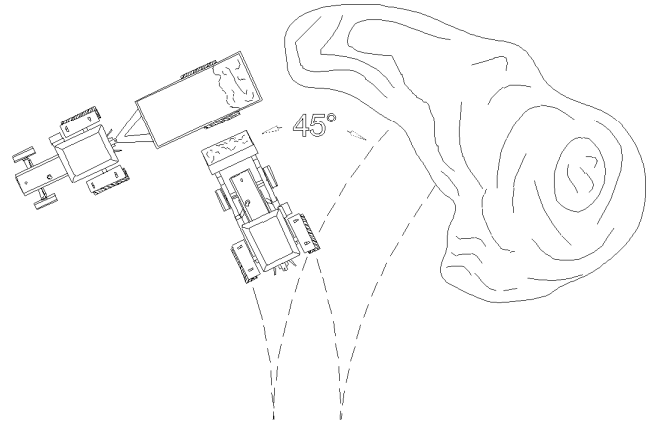

Dumping The Bucket

Lower a heavy load slowly. Stopping a heavy loader suddenly after it has gained downward momentum may result in damage to the loader/tractor unit.

When dumping a load into a vehicle, lift the bucket high enough to clear the side of the vehicle and move the tractor in as close as possible before dumping the bucket. After dumping, back away from the vehicle until loader is clear, lower loader to travel height then proceed to reverse away looking in the direction of travel.



CAUTION!

Do not use the "float" position of the hydraulic control valve to lower the loader. Loss of control results and the loader boom arms will fall due to its own weight.

Back Grading

To back grade the work surface orientate the bucket so that the bottom of the bucket is horizontal to ground line, using the heel of the bucket to move material while the bottom creates a smooth flat surface. This can be done with the bucket loaded (using weight of bucket) and the lift circuit in float allowing loader frame arms to maintain bucket contact to work area while tractor travels over uneven ground. Alternately with the bucket flat but empty you can apply slight down pressure with loader frame arms.

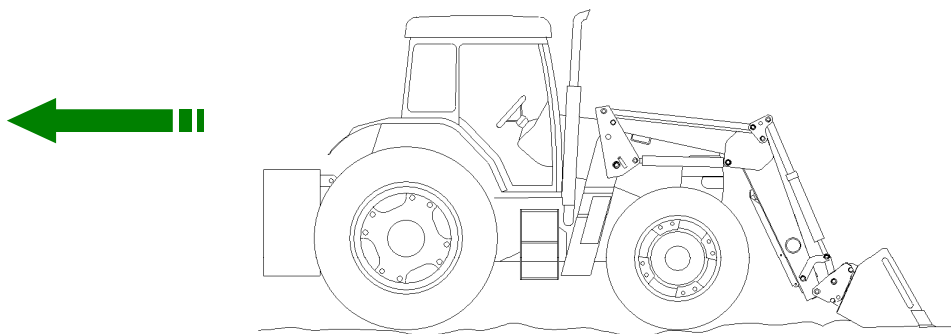

Digging With Bucket

Adjust bucket to level position and lower frame arms to the ground. Drive forward and tilt the bucket forward making it penetrate the ground, once the cut has been started roll the bucket back to the level position and at the same time lower the frame arms, use the bucket cylinders to adjust and maintain a cut 50~70mm deep, move forward until bucket is full and crowd bucket back, continue this sequence until total required depth is reached. Wheel spin will be avoided if the cut is not too deep, but within reason the nature of the soil will determine the depth of cut that can be taken.

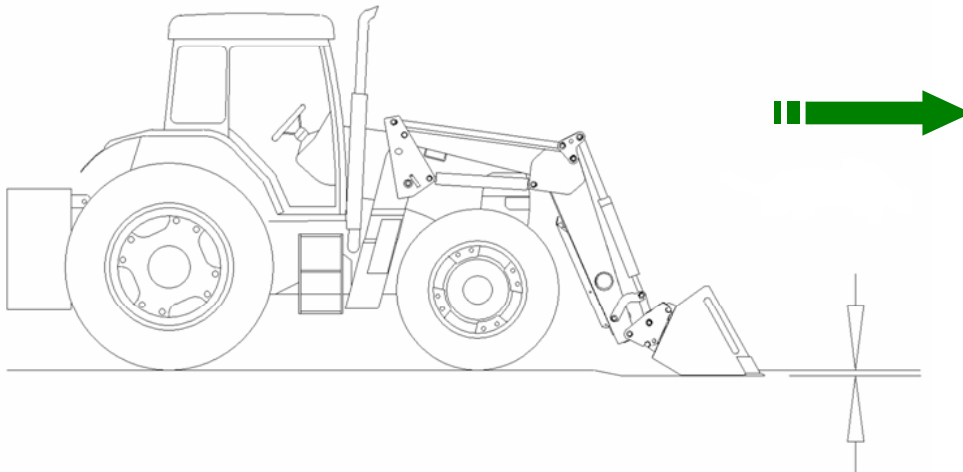

CAUTION!



Check underground utility locations before digging. To help prevent bodily injury or death, do not leave the operator's seat if any part of the loader comes into contact with cables. Back away from the cable before getting off the tractor. Call the relevant authorities.

Backfilling

Approach the pile with bucket bottom level and flat on ground.

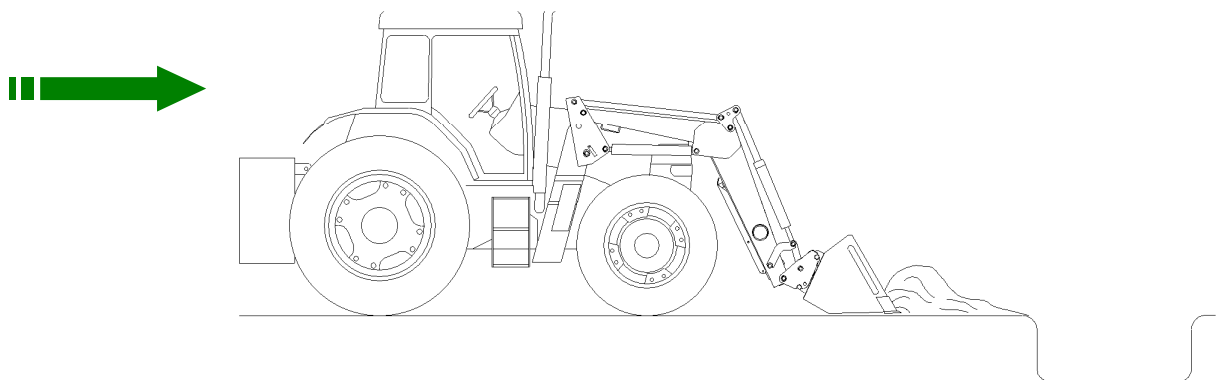

Leave any dirt in the bucket as dumping on each pass wastes time.

Do not use the bucket in the dump position for backfilling or back grading, as this will impose severe shock loading on the bucket cylinders, top link bars and allows excess wear to the cutting edge. Using the bucket in this position also makes it more difficult to maintain a level surface.

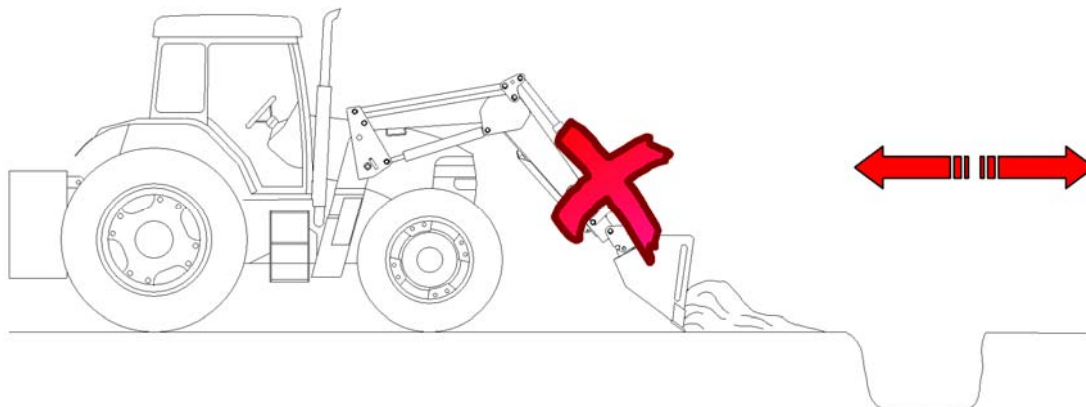

Incorrect Loading

Avoid side loads to the tractor, mounting kit and loader frame.
Do not drive in forwards or reverse with the front wheels turned when an attachment is touching the ground. This could result in damage to the Front End Loader.

Avoid heavy off-centre loading of the attachment.

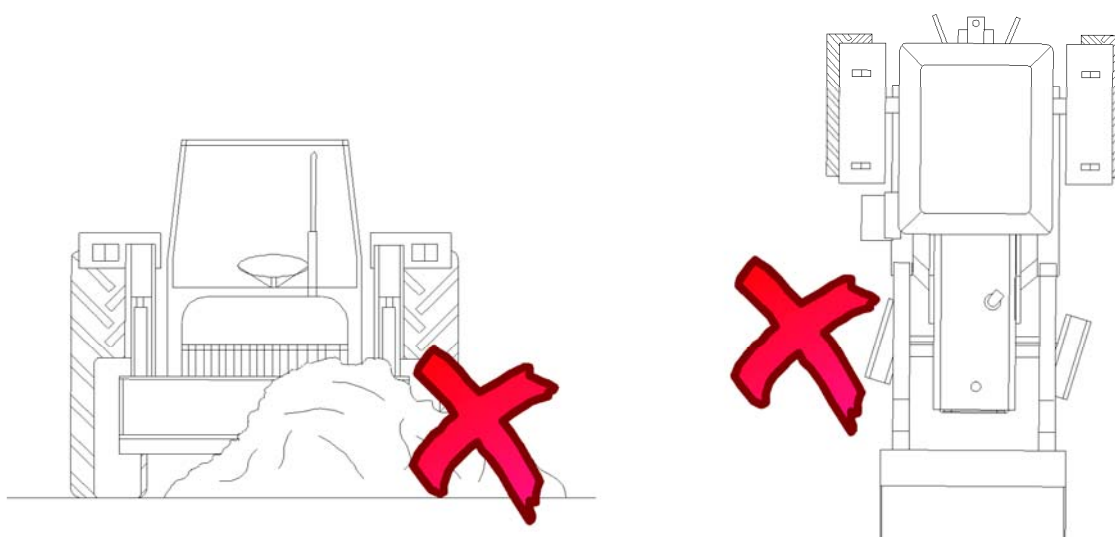

Avoid these loading conditions when using your Front End Loader

ATTACHING AND DETACHING LOADER FRAME ARMS

Attaching and detaching a Tae-Sung Loader is a simple, quick, one-man operation using two simple latch-pins to securely lock the loader frame arms to the tractor mounting kit. The following steps are designed to assist in this operation.

Detaching Procedure



CAUTION!

To prevent personal injury or death from falling loader, always detach on a hard, level surface. Loader must be fitted with an earthmoving bucket.

Place the tractor on a hard, level surface and ensure that a bucket is fitted to the loader. Care should always be taken to be aware of people in the area and to give adequate clearance for reversing & manoeuvring.

- STEP 1: Dump bucket approximately 15° and lower loader Frame arms so that bucket cutting edge is just above ground.

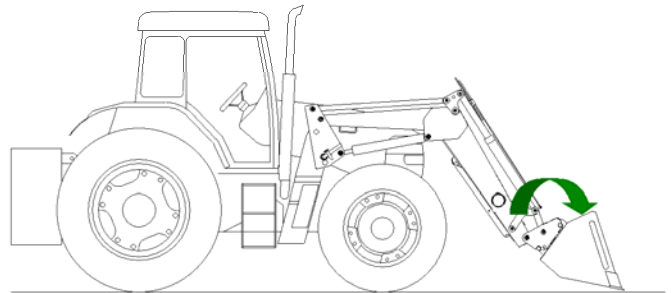

- STEP 2: Lower the frame stands by pulling them out of their mounts, remove "R" clip from inner stay raising into locking position and securing using the same "R" clip. (Ensure that both frame stands are set equal in length, once inner stays have been adjusted for your tractor future adjustment should not be required.)

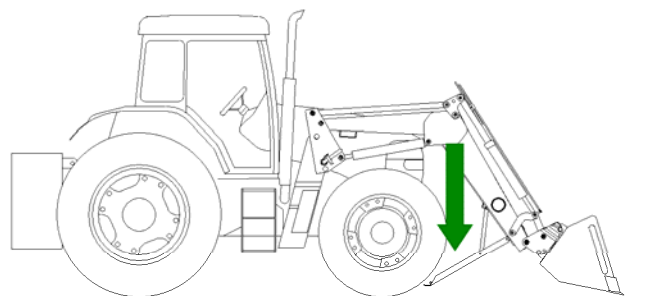

- STEP 3: Remove Ring-Pins located above Latch-Pins.

- STEP 4: Remove Latch-Pins.

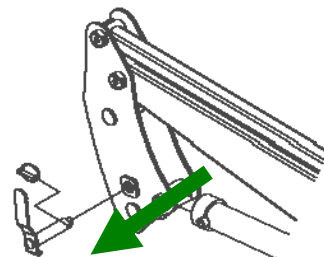

STEP 5: Lower loader frame arms to ground and completely close *lift* cylinders. (This will disengage the lower locking pins of the top posts from the mounting kit).

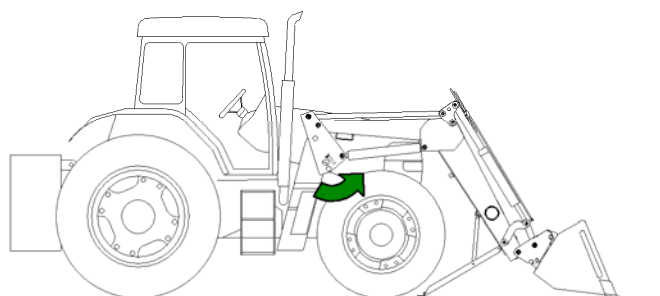

STEP 6: Slightly crowd the bucket back which will raise the back of the loader frame arms disengaging the top locking pins of the top post from the mounting kit. With loader frame arms just clear of mounting kit stop crowding bucket. Place the tractor in neutral with the park brake disengaged for this operation. (If loader frame arms don't come loose tractor may have to be carefully driven 2-3 cm forward, or check adjustment of frame stands.)

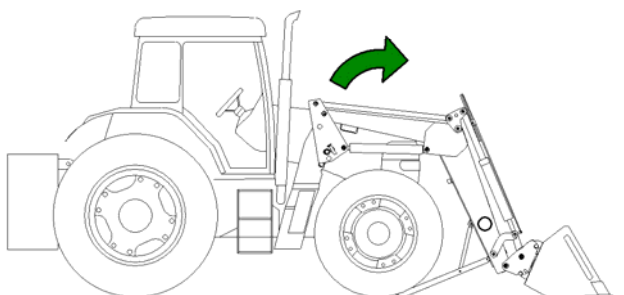

STEP 7: Turn off tractor; operate loader controls to relieve hydraulic pressure. Then disconnect hydraulic hoses and place dust caps onto quick-couplings.

STEP 8: Reverse the tractor carefully until it is completely free of the loader.

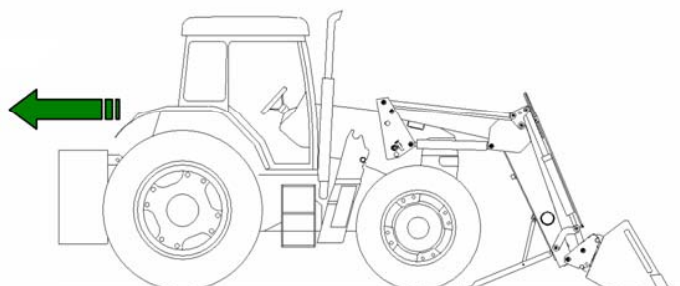

NOTE! Make sure that the hydraulic hoses don't get caught on the tractor.

Attaching Procedure

STEP 1: Carefully drive tractor between loader frame arms.

STEP 2: Reconnect hydraulic hoses ensuring that they are connected correctly by matching the dust cap colours.

STEP 3: Slightly dump bucket to lower the back of the loader frame arms until the top locking pins engage into the mounting kit. (Reverse STEP 6 *Detaching Procedure*)

STEP 4: Operate control lever in the raise direction to extend lift cylinders, as cylinders extend the lower locking pins will engage into the mounting kit and loader frame arms will raise, stop the lifting operation with the bucket approximately 1 metre off the ground.

STEP 5: Replace Latch-pins and Ring-pins.

STEP 6: Fold away inner stays and raise frame stands pushing firmly into mounts.

NOTE: A small amount of grease applied to the contacting surfaces between the top posts and the mounting kit will assist attaching and detaching of loader frame arms.

ATTACHING AND DETACHING ATTACHMENTS

Attaching Attachments

- Start the tractor and raise the loader frame arms approximately 1 metre off the ground then extend the bucket cylinders slightly inclining quick coupler forward.

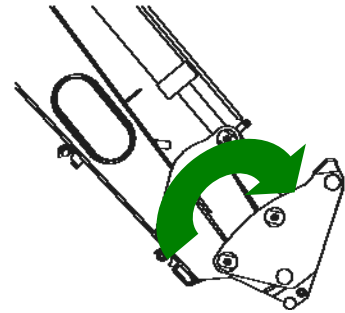

- Pull the Quick-Lock handle over past the stop block to the open pin position. (Left to right as you face the tractor)

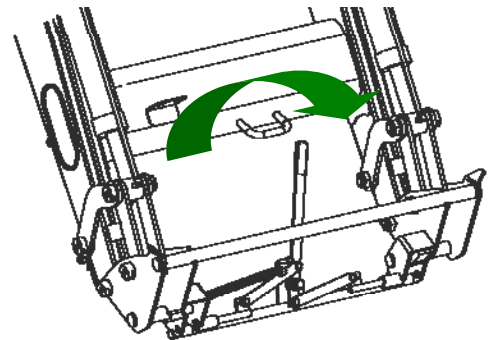

- Move the tractor/loader forward against the attachment aligning the quick coupler beneath the attaching hooks.

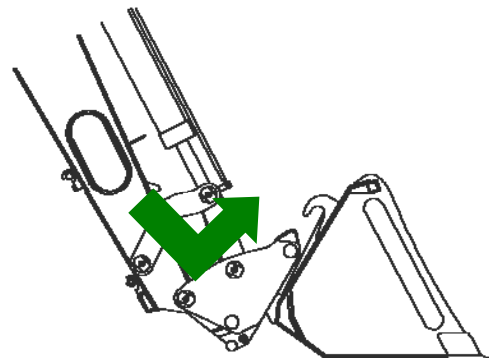

- Raise loader frame arms until quick coupler fits up into attaching hooks then crowd attachment back fully. The Quick-Lock handle will then be disengaged as it hits the striking plate, automatically locking the attachment to the quick coupler.

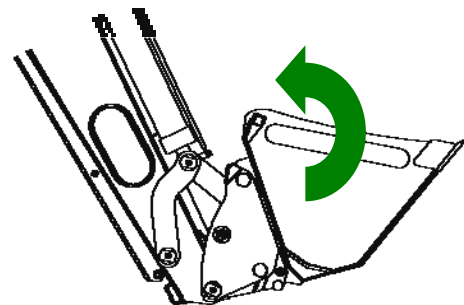

- After the locking process is verified as being successfully completed the loader and attachment are safe for use.

Detaching Attachments

- With loader frame arms approximately 1 metre off the ground extend the bucket cylinders slightly inclining quick coupler forward. (Until front of attachment is lower than the rear).
- Pull the Quick-Lock handle over past the stop block to the open pin position. (Left to right as you face the tractor)
- Lower loader frame arms placing attachment on the ground, continue lowering frame arms until quick coupler clears attachment hooks and reverse tractor/loader away. The Quick- Lock Quick Coupler is now ready to accept another attachment.

LUBRICATION AND MAINTENANCE

CAUTION!



Before servicing the unit and performing maintenance stop the tractor, lower the loader to the ground, set the parking brake, disengage the Power Take Off and all power drives, shut off the tractor engine and remove the ignition key.

Lubrication

Lubrication is one of the most important aspects of service, as it increases the loader life by decreasing the friction between moving parts. Lubrication should be carried out on a daily basis or every 8 hours under normal operating conditions, and more often under extreme conditions.

Lubrication fittings (in the form of grease nipples) are located at all pivot points on the loader. These fittings are one-way valves through which a lubricant (grease) can be supplied to a bearing via the use of a grease gun.

To ensure complete lubrication of the pivot pins, lower the loader to rest the attachment on the ground, stop the engine and release the hydraulic pressure in the cylinders. Use a good grade of lubricant/grease that is suitable for general-purpose application. Remove all dirt from the lubrication point before greasing and remember to wipe off excess grease after lubricating.

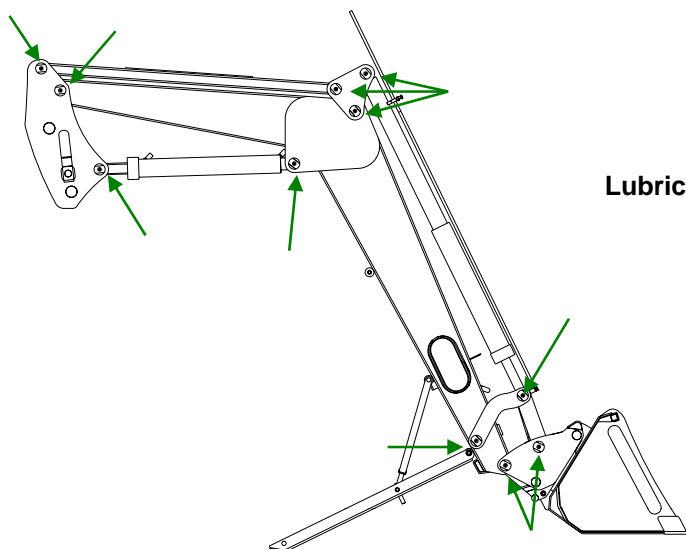

Lubrication Points on a "700" Series Loader.

No. Per side =11

Total = 22

PART ILLUSTRATIONS

GENERAL INFORMATION

Illustrations

The individual parts in their normal relationship to each other. Reference numbers are used in the illustrations. These numbers correspond to those in the "Number" column and are followed by the quantity required and description.

Directional Reference

"Right hand" and "left hand" sides are determined by standing at the rear of the unit and facing in the direction of forward travel.

Parts Order

Orders must give the complete description, correct part number, the total amount required, the product model, all the necessary serial numbers, the method of shipment and the shipping address.

Instructions

1. GROUP NAME

: Detail classification name for parts.

2. SECTION NAME

: Classification name for parts.

3. COMPONENTS



: The components of an assembly are identified by a bracket.

4. NO.

: Reference numbers are assigned to parts in the figure.

INTERCHANGEABILITY

: Indicates the interchangeability of parts due to design change

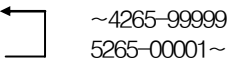
	<p>Indicates that a new part can be used instead of an old part when you order this part, please order new part.</p>
	<p>indicates that either parts can be used.</p>
	<p>indicates that either parts can not be used.</p>
	<p>indicates that a part has a serial number break. When you order this part, please order a part according to the serial number of the Loader.</p>

★ Due to our policy of continuously improving products, The information contained herein is subject to change without notice.

MOUNTING FRAME ASSEMBLY

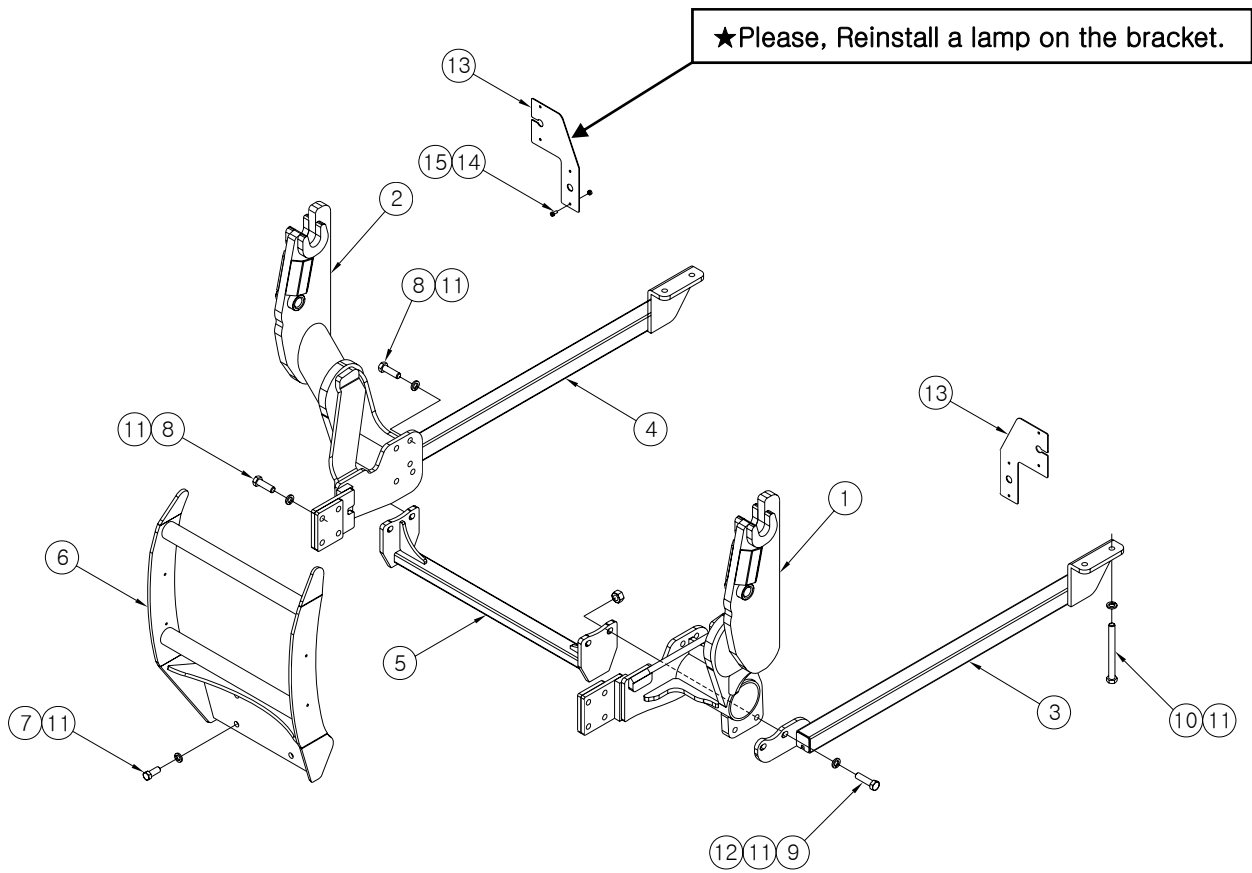

MOUNTING FRAME ASSEMBLY

REF.NO	PART.NO	DESCRIPTION	QTY	I.C	REMARK
1	FT110-11100	MOUNTING FRAME-LH	1		
2	FT110-11200	MOUNTING FRAME-RH	1		
3	FT110-11300	REAR FRAME ASS'Y-LH	1		
4	FT110-11400	REAR FRAME ASS'Y-RH	1		
5	FT110-11500	CROSS BAR ASS'Y	1		
6	FT110-G1000	GRILL ASS'Y	1		
7	10191-M1406-30	HEX. BOLT-HT, M14-2.0P 30L	4		
8	10191-M1406-45	HEX. BOLT-HT, M14-2.0P 45L	18		
9	10191-M1406-55	HEX. BOLT-HT, M14-2.0P 50L	4		
10	10191-M1406-60	HEX. BOLT-HT, M14-2.0P 60L	4		
11	10316-M1400	WASHER-SPRING, M14	30		
12	10261-M1406	HEX. NUT-HT, M14-2.0P	4		
13	FT110-11601	BRACKET, LAMP	2		
14	1012S-M0408-12	SEM'S PIECE	4		
15	10211-M0408	HEX. NUT, M4-0.7P	4		

HYDRAULIC CONNECTING

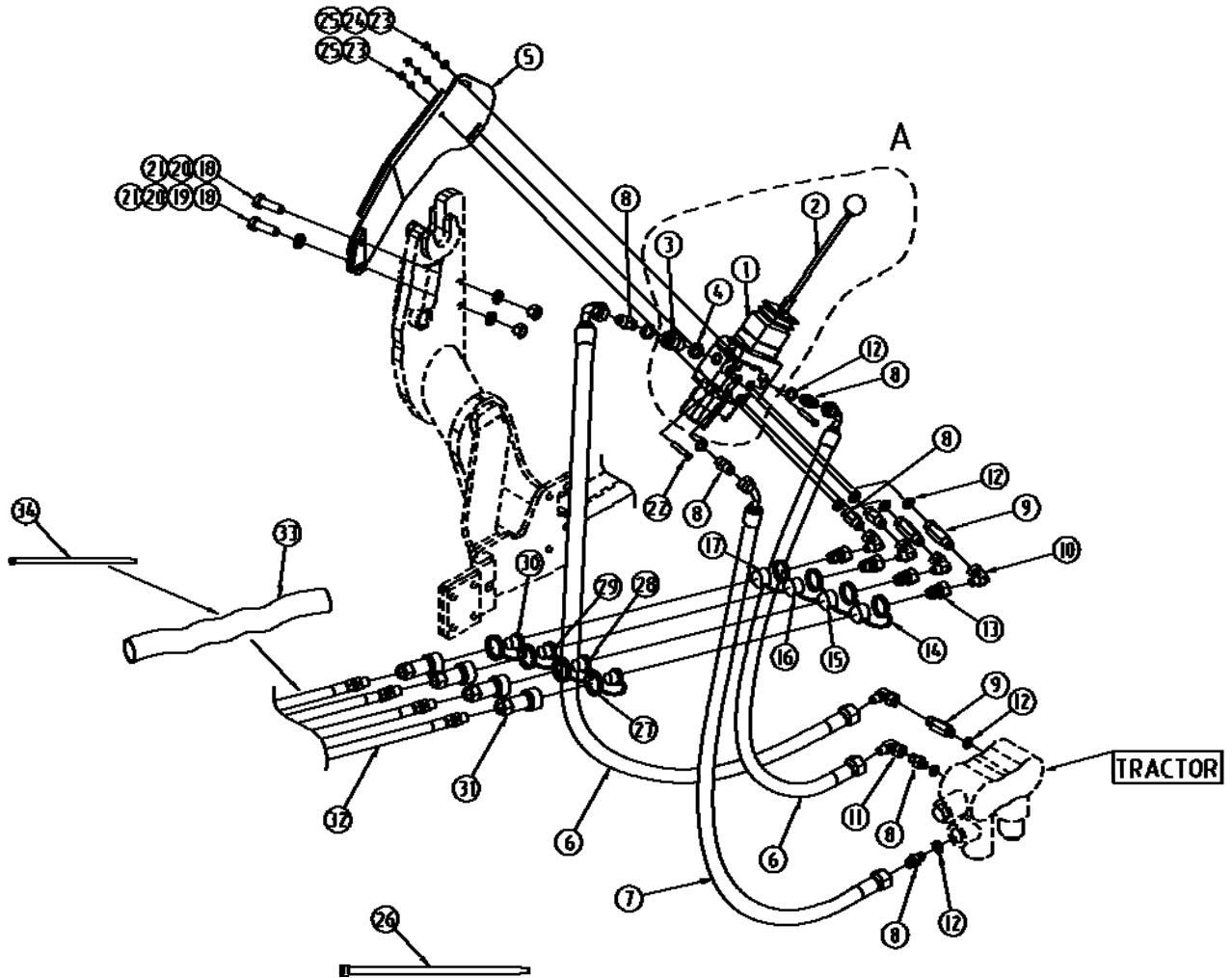

HYDRAULIC CONNECTING

REF.NO	PART.NO	DESCRIPTION	QTY	I.C	REMARK
1	801D1-82000	DN2 VAVLE	1		
2	801D1-80J00	DN2 VAVLE LEVER + NUT	1		
3	801Z2-82101	CARRY OVER, PF1/2xPF3/8	1		
4	103E1-C0110	BONDSEAL, 1/2"	1		
5	FT110-V0100	VAVLE BRACKET ASS'Y	1		
6	80620-05048	HOSE ASS'Y, 904(3/4-16UNF)-4(3/4-16UNF) 1200L(3/8)	2		
7	80620-05051	HOSE ASS'Y, 904(3/4-16UNF)-4(3/4-16UNF) 1400L(3/8)	1		
8	802N2-P46F9-41	NIPPLE, PF3/8,COPPERx3/4-16UNF,HOSE	7		
9	802N2-P46F9-4M	NIPPLEPF3/8,COPPERx3/4-16UNF,HOSE - LONG	3		
10	802L0-T46F9-4S	NIPPLE, PT3/8*3/4-16UNF,SWIVEL 90 °	4		
11	802L2-F94F9-4S	NIPPLE, 3/4-16UNF,HOSEx3/4-16UNF,SWIVEL 90 ° 4-TYPE	2		
12	103C0-C0330	WASHER, COPPER, Φ17xΦ24	10		
13	80410-T3360	QUICK COUPLER, PT3/8, MALE	4		
14	8043B-03300	DUST CAP, 3/8" FEMALE, BLUE	1		
15	8043R-03300	DUST CAP, 3/8" FEMALE, RED	1		
16	8043Y-03300	DUST CAP, 3/8" FEMALE, YELLOW	1		
17	8043K-03300	DUST CAP, 3/8" FEMALE, BLACK	1		
18	10121-M1205-45	HEX. BOLT, M12-1.75P 45L	2		
19	10316-M1200	WASHER-PLAIN, M12	1		
20	10316-M1200	WASHER-SPRING, Φ12	2		
21	10211-M1205	HEX. NUT, M12-1.75P	2		
22	10121-M0803-50	HEX. BOLT, M8-1.25P 50L	3		
23	10321-M0800	WASHER-PLAIN, M8	2		
24	10316-M0800	WASHER-SPRING, Φ8	3		
25	10211-M0803	HEX. NUT, M8-1.25P	3		
26	50120-M540K	CABLE TIE, 540mm, BLACK	3		
27	FT110-V3001	HANESS CABLE, (F2xM1)-(F1xM2) 200L	2		F:FEMALE, M:MALE

BOOM ASSEMBLY (Self Leveling Device)

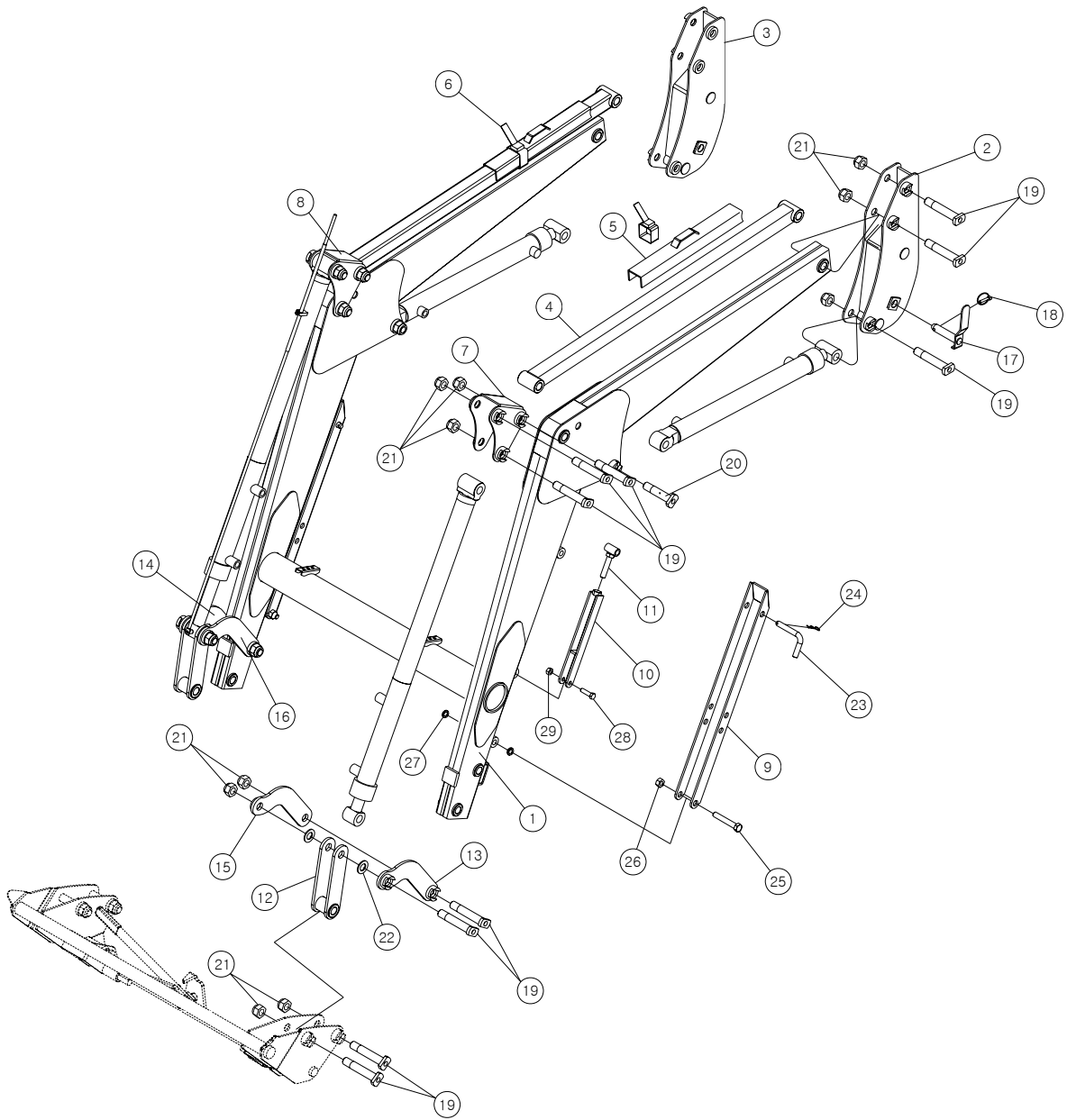



BOOM ASSEMBLY (Self Leveling Device)

REF.NO	PART.NO	DESCRIPTION	QTY	I.C	REMARK
1	LTF63-12100-02	BOOM W.A	1		
2	LTM23-32300	TOP POST-LH	1		
3	LTM23-32400	TOP POST-RH	1		
4	LTS21-51510	LINK W.A LEVEL	2		
5	50140-M600K	SAFTY BAR W.A	2		
6	LTS19-51120-01	STRAP-LOCK, 600L	2		
7	FTF40-51500	LINK-L/H	1		
8	FTF40-51600	LINK-R/H	1		
9	LTS19-61111-01	STAND	2		
10	LTS19-61120-01	STAND W.A	2		
11	LTS21-61130	BOLT W.A	2		
12	LTF63-51410	LINK W.A	2		
13	LTS19-51310	LINK W.A-BUCKET	1		
14	LTS19-51320	LINK W.A-BUCKET	1		
15	LTS19-51330	LINK W.A-BUCKET	1		
16	LTS19-51340	LINK W.A-BUCKET	1		
17	LTS19-31500	PIN W.A, $\Phi 25-106.3L$	2		
18	14021-10000	RING PIN, $\Phi 10$	2		
19	14124-25130-N	PIN, M24-130L	20		
20	14124-25110-N	PIN, M24-110L	2		
21	1021M-M2404	NUT-SELFLOCK, M24-1.5P	22		
22	10321-M2400	WASHER-PLAIN, M24	4		
23	LTL26-61201	PIN-HAND, $\Phi 16-110L$	2		
24	14011-03000	R-PIN, $\Phi 3$	2		
25	10191-M1606-90	HEX.BOLT, M16-2.0P 90L	2		
26	10211-M1606	NUT-SELFLOCK, M16-2.0P	2		
27	10321-M1600	WASHER-PLAIN, M16	4		
28	10191-M1205-45	HEX.BOLT, M12-1.75P 45L	2		
29	1021N-M1205	NUT-SELFLOCK, M12-1.75P	2		

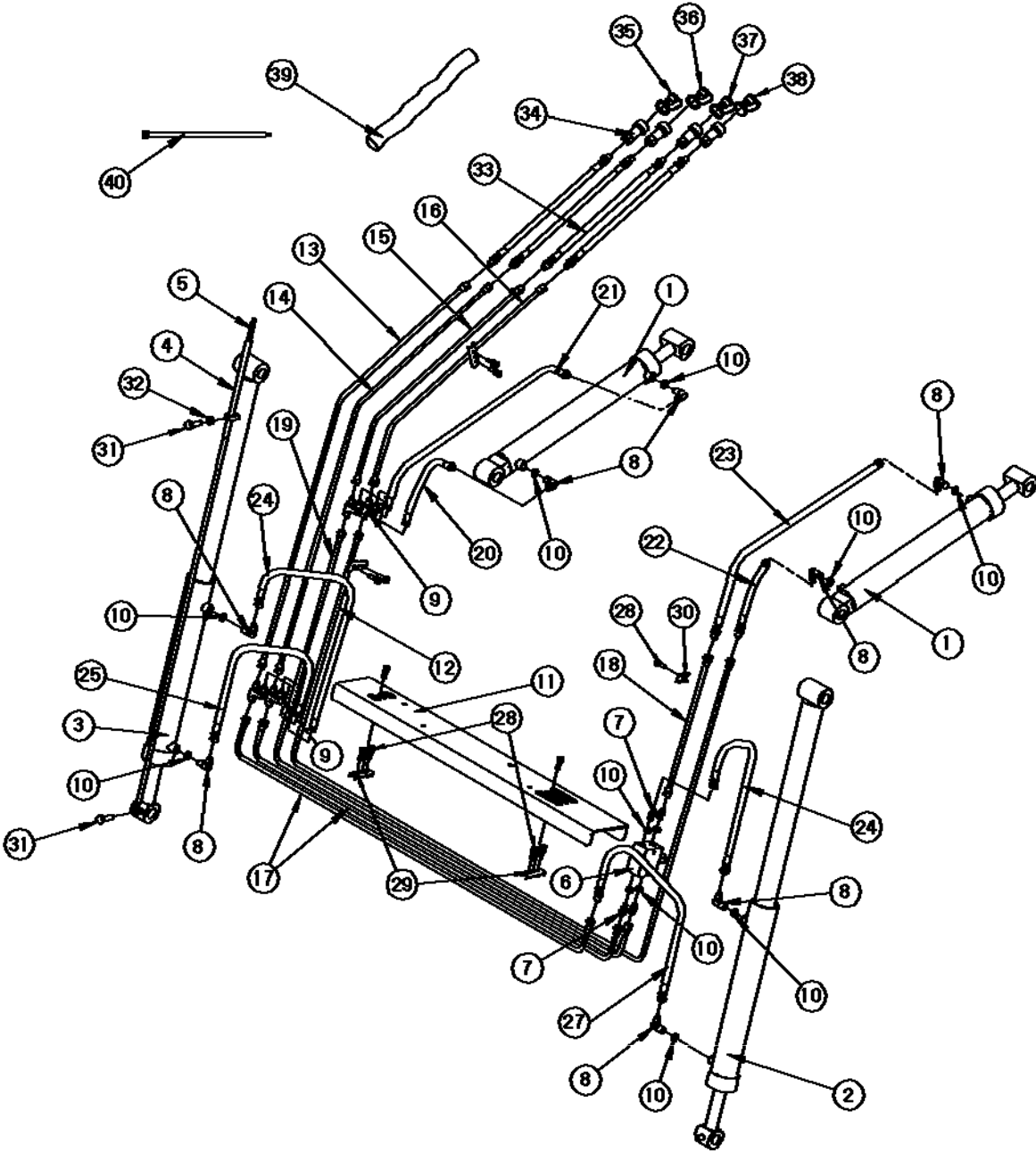
HYDRAULIC PIPING (Self Leveling Device)



HYDRAULIC PIPING (Self Leveling Device)

REF.NO	PART.NO	DESCRIPTION	QTY	I.C	REMARK
1	226105	BOOM CYLINDER ASS'Y	2		
2	226101	BUCKET CYLINDER ASS'Y-LH	1		
3	226602	BUCKET CYLINDER ASS'Y-RH	1		
4	14712-50022	TUBE	1		
5	LTM23-72300	BAR. GAUGE-LONG, Φ 12x1200L	1		
6	801T1-50000	VALVE, RELIFE	1		
7	802N2-P46F9-42	NIPPLE, 3/4-16UNF, HOSExPF3/8, O-RING	4		
8	802L2-F94P4-62	NIPPLE, 3/4-16UNF, HOSExPF3/8, O-RING 90°	8		
9	802H1-F94F9-40	NIPPLE, 3/4-16UNF, h TYPE	4		
10	81301-BP014	O-RING, 1PB14	12		
11	LTS19-17801	COVER, PIPE	1		
11	LTS19-17801-01	COVER, PIPE	1		80811001~
12	LTM23-82510	PIPE ASS'Y	1		
13	LTM23-82520	PIPE ASS'Y	1		
14	LTM23-82530	PIPE ASS'Y	1		
15	LTM23-82540	PIPE ASS'Y	1		
16	LTM23-82550	PIPE ASS'Y	1		
17	LTM23-82560	PIPE ASS'Y	2		
18	LTM23-82580	PIPE ASS'Y	1		
19	LTM23-82570	PIPE ASS'Y	1		
20	80620-01027	HOSE ASS'Y, 4(3/4-16UNF)-4(3/4-16UNF) 450L(3/8)	1		
21	80620-01044	HOSE ASS'Y, 4(3/4-16UNF)-4(3/4-16UNF) 900L(3/8)	1		
22	80620-03011	HOSE ASS'Y, 4(3/4-16UNF)-2(3/4-16UNF) 450L(3/8)	1		
23	80620-03017	HOSE ASS'Y, 4(3/4-16UNF)-2(3/4-16UNF) 900L(3/8)	1		
24	80620-01024	HOSE ASS'Y, 4(3/4-16UNF)-4(3/4-16UNF) 700L(3/8)	2		
26	80620-01016	HOSE ASS'Y, 4(3/4-16UNF)-4(3/4-16UNF) 800L(3/8)	1		
27	80620-03023	HOSE ASS'Y, 4(3/4-16UNF)-2(3/4-16UNF) 800L(3/8)	1		
28	1012S-M0803-35	BOLT-Sem's, M8-1.25P 35L	11		
29	LTL26-81801	CLAMP	4		
30	LTL26-81802	CLAMP	1		
31	10121-M1004-30	HEX.BOLT, M10-1.5P 30L	2		
32	10211-M1004	HEX.NUT, M10-1.5P	1		
33	80620-04006	HOSE ASS'Y, 1(PT3/8)-2(3/4-16UNF) 1000L(3/8)	4		
34	80420-T3360	QUICK COUPLER, PT3/8 FEMALE	4		
35	8044R-03300	DUST CAP, 3/8 RED	1		
36	8044B-03300	DUST CAP, 3/8 BLUE	1		

HYDRAULIC PIPING (Self Leveling Device)

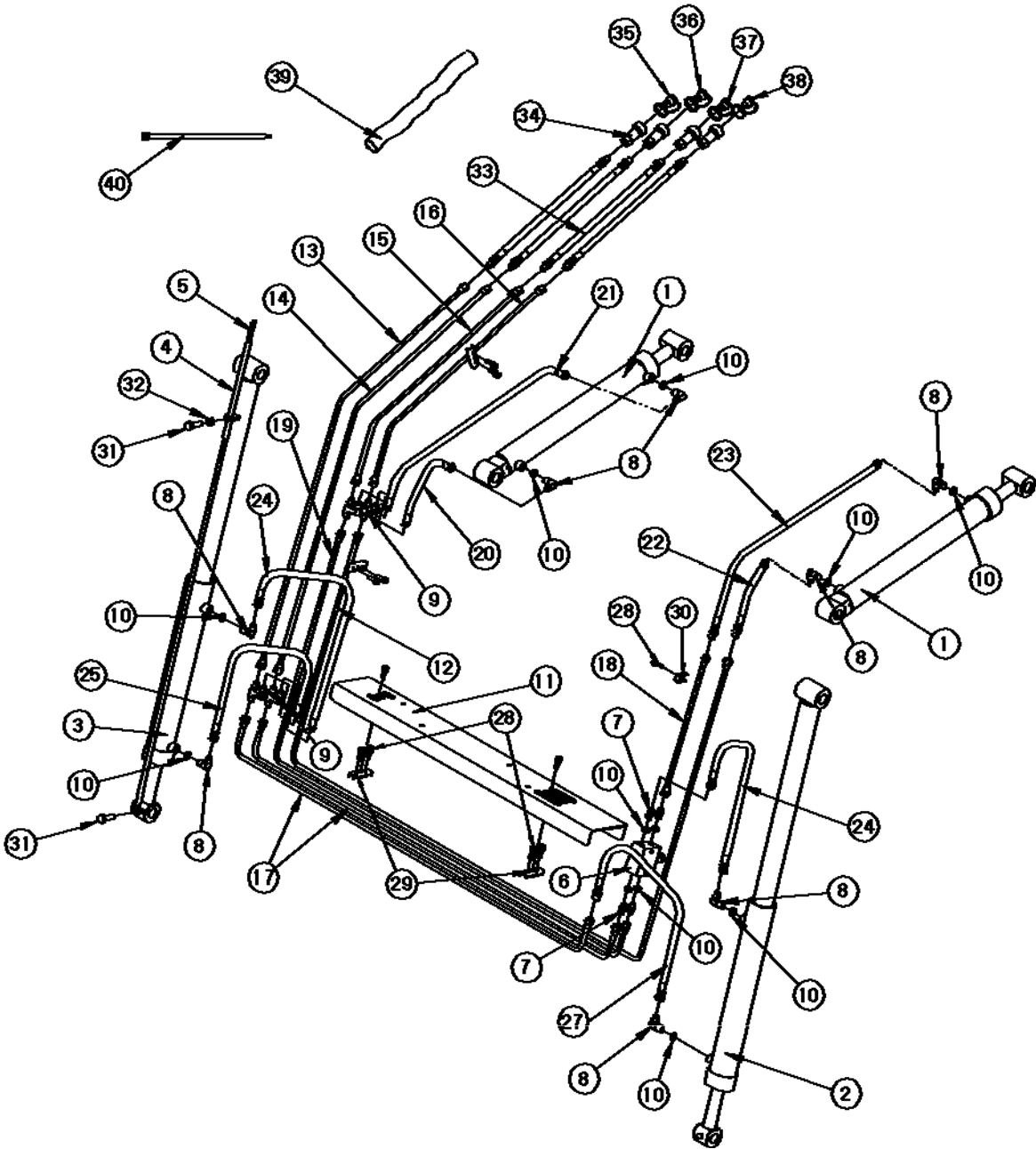

HYDRAULIC PIPING (Self Leveling Device)

REF.NO	PART.NO	DESCRIPTION	QTY	I.C	REMARK
37	8044Y-03300	DUST CAP, 3/8 YELLOW	1		
38	8044K-03300	DUST CAP, 3/8 BLACK	1		
39	50130-0550K	HOSE WEBBING, 90-550L	1		
40	50120-M270K	CABLE TIE, 270mm BLACK	2		

QUICK ATTACHMENT

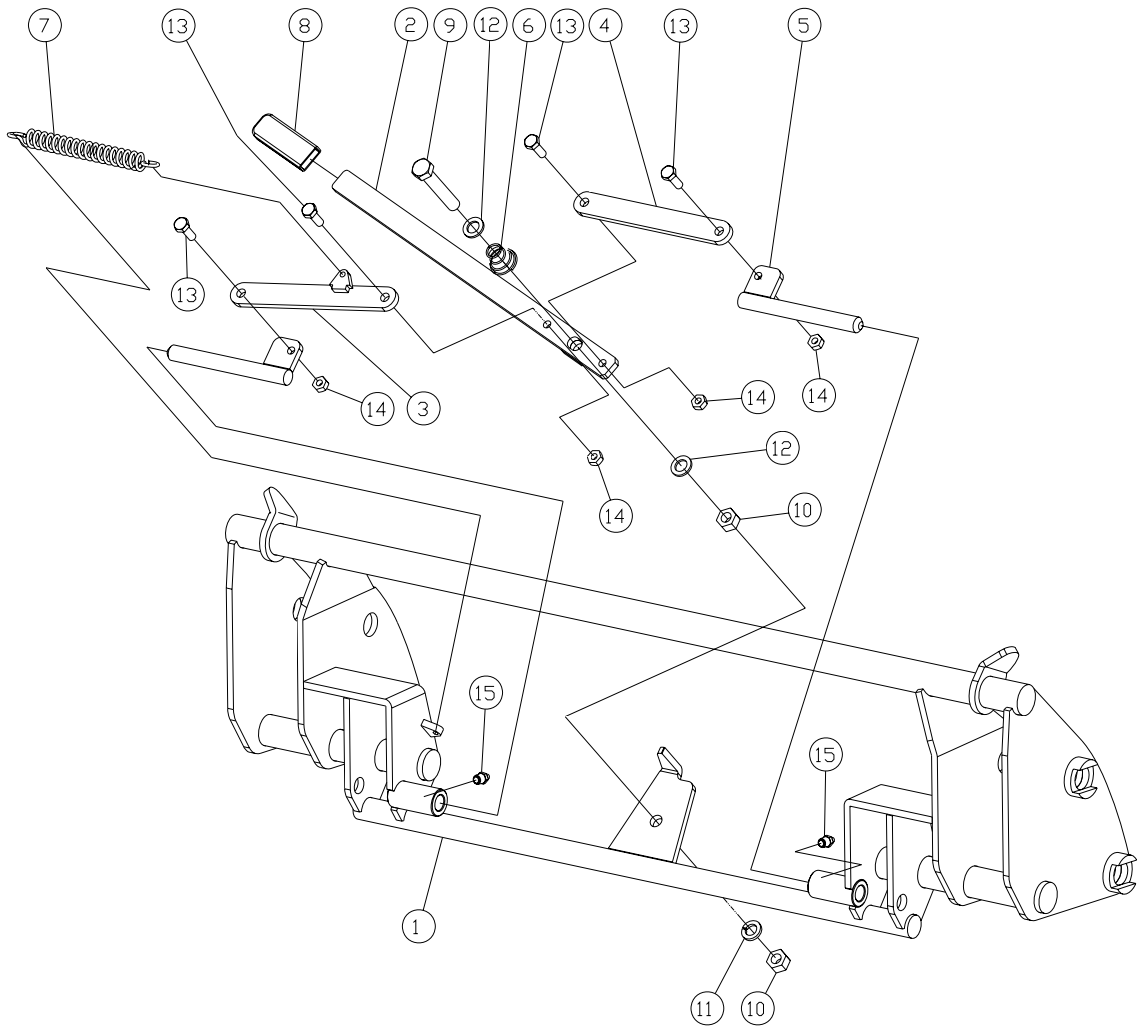

QUICK ATTACHMENT

REF.NO	PART.NO	DESCRIPTION	QTY	I.C	REMARK
-	LTS19-44000	QUICK ATTA. ASS'Y	-		
1	LTS19-44100	QUICK ATTA. W.A	1		
2	LTL28-41510	LEVER W.A-QUICK	1		
3	LTS19-43520	LINK W.A-QUICK	1		
4	LTS19-43521	LINK-QUICK	1		
5	LTS19-43540	PIN W.A-QUICK	2		
6	LTL26-41551	SPRING	1		
7	LTL26-41552-01	SPRING	1		
8	BN01-0904	GRIP-RUBBER	1		
9	10191-M1606-90	BOLT-HEX	1		
10	10261-M1606	NUT-HEX	2		
11	10316-M1600	WASHER-SPRING	1		
12	10321-M1600	WASHER-PLAIN	2		
13	10191-M1004-35	BOLT-HEX	4		
14	1021N-M1004	NUT-SELFLOCK	4		
15	802G0-T1900	NIPPLE, GREASE	2		

BUCKET ASSEMBLY

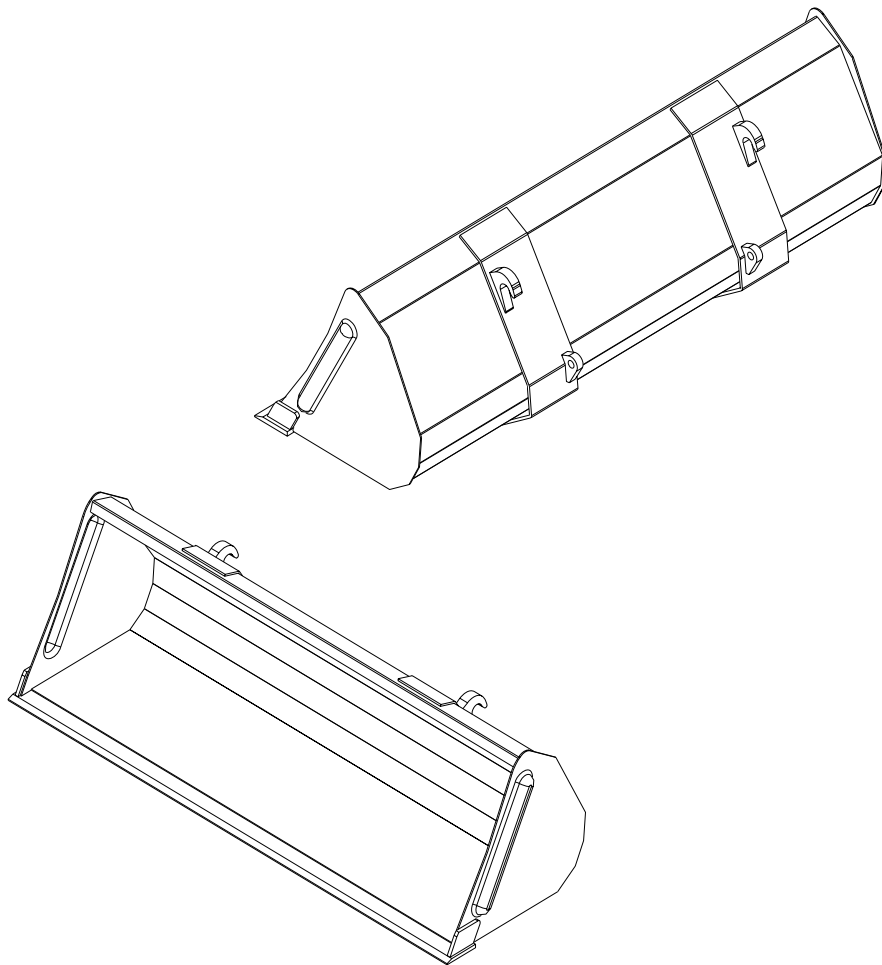

BUCKET ASSEMBLY

REF.NO	PART.NO	DESCRIPTION	QTY	I.C	REMARK
-	LTS19-29700-01	BUCKET W.A(67")	1		

BOOM CYLINDER

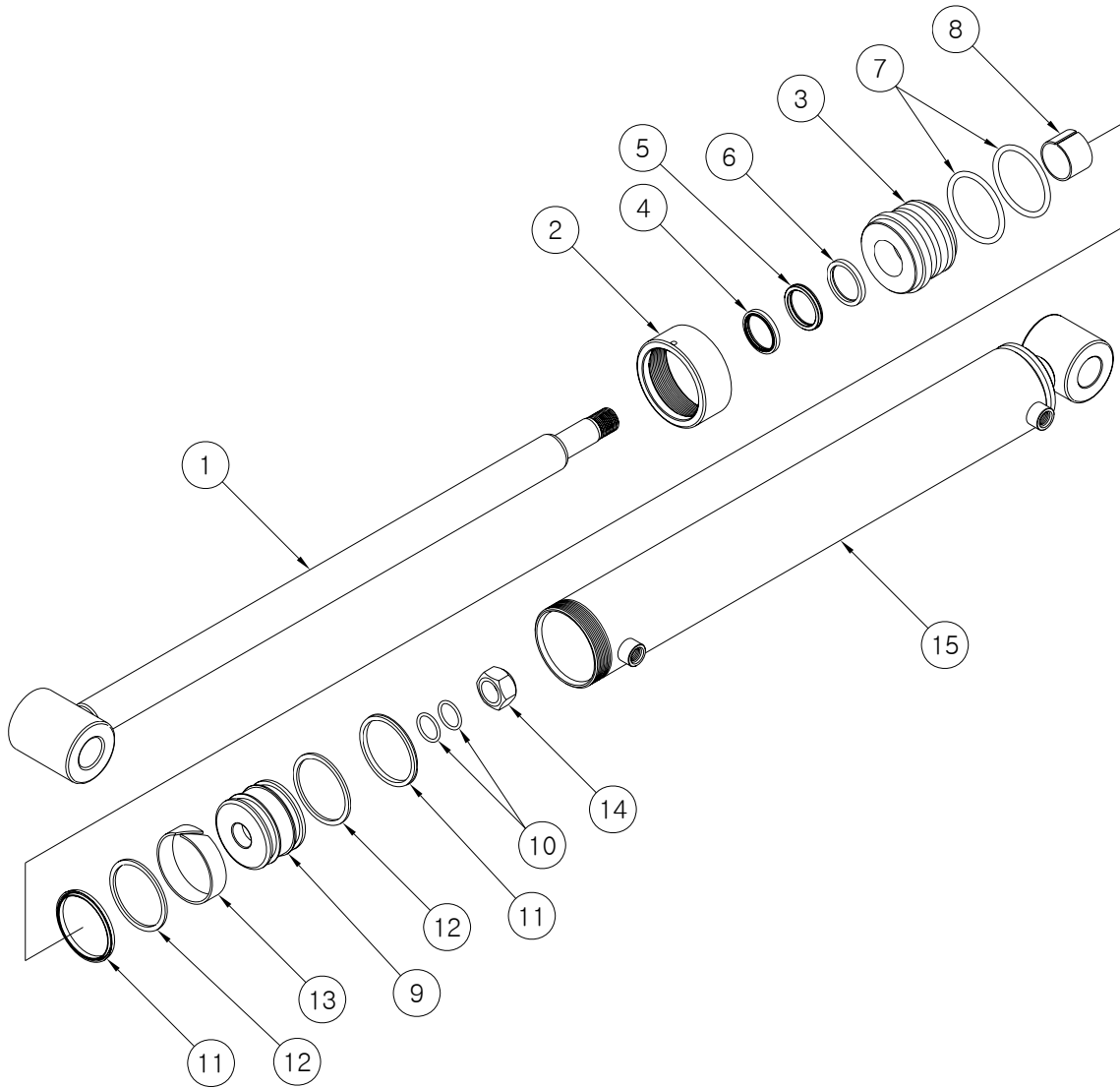

BOOM CYLINDER

REF.NO	PART.NO	DESCRIPTION	QTY	I.C	REMARK
0	226105	BOOM CYLINDER ASS'Y	2		
1	226105-R	ROD ASS'Y	1		
2	OC60-7040	CAP OUTER, Φ 60x70x40L	1		
3	IC60-3565	COVER INNER, Φ 60x35x65L	1		
4	DSSD-R035	DUST SDR, 35x43x5/6.5	1		
5	UPSK-Y035	PACKING U, SKY 35x45x6	1		
6	UPIS-I035	PACKING U, ISI 35x45x6	1		
7	OR1B-G055	O-RING, 1BG55	2		
8	DU03-5030	BUSHING DU, 35x39x30	1		
9	PI60-2746	PISTON, Φ 60x27x46L	1		
10	OR1B-G027	O-RING, 1BG27	2		
11	UPOS-I060	PACKING U, OSI 60x50x6	2		
12	TRBR-0060	BACKUP RING, 60x50x3	2		
13	WEWR-0060	WEARING, WR 60x55x15	1		
14	NTP0-U100-C	NUT, 1-14UN	1		
15	226105-T	TUBE ASS'Y	1		
16	IA60-3565	SEAL KIT HEAD, No.3~8	1		
17	PA60-2746	SEAL KIT PISTON, No.9~13	1		

BUCKET CYLINDER ASS'Y-LH

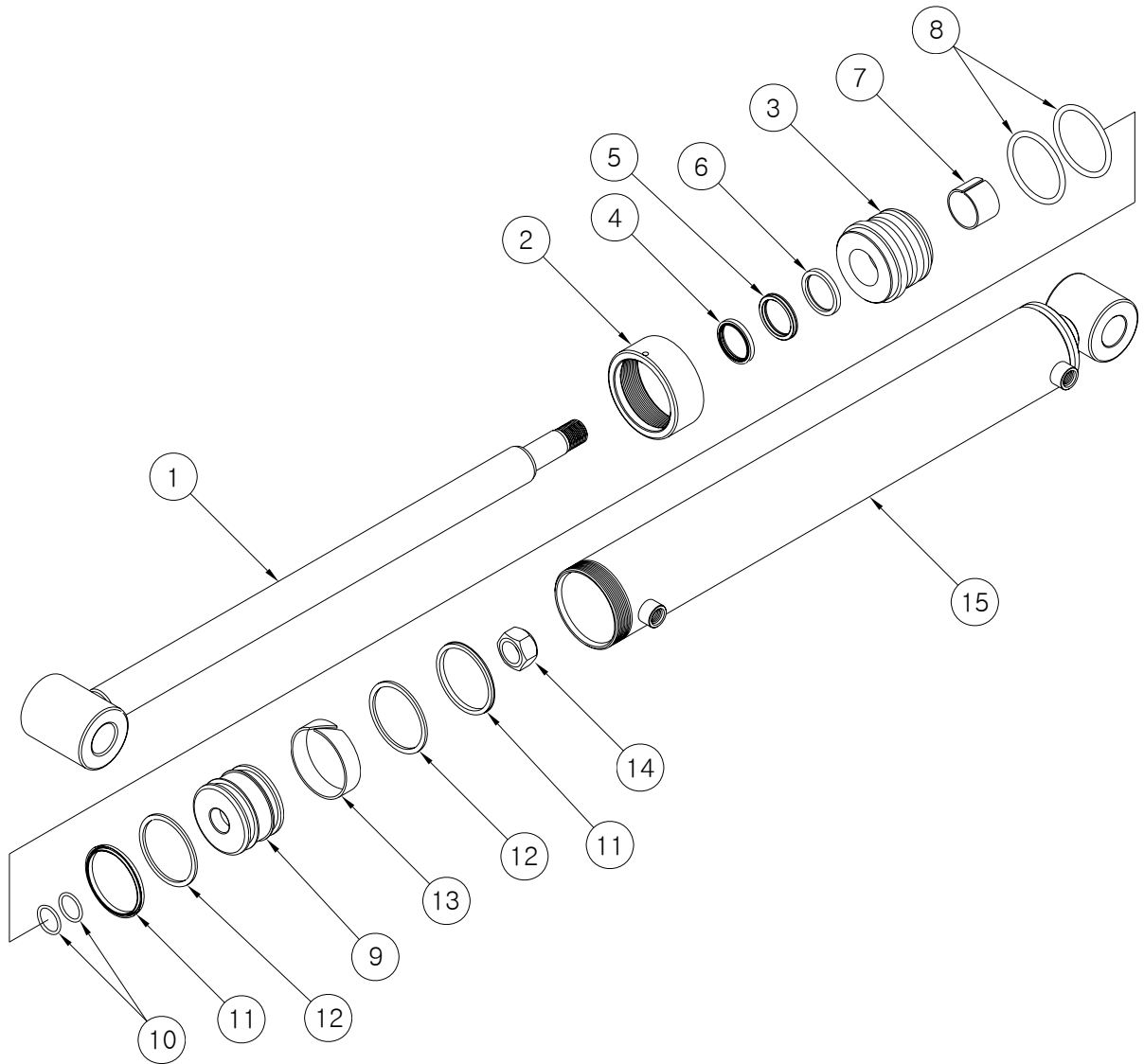

BUCKET CYLINDER ASS'Y-LH

REF.NO	PART.NO	DESCRIPTION	QTY	I.C	REMARK
0	226101	BUCKET CYLINDER ASS'Y-LH	1		
1	226101-R	ROD ASS'Y	1		
2	OC60-7040	CAP OUTER, Φ60x70x40L	1		
3	IC60-3565	COVER INNER, Φ60x35x65L	1		
4	DSSD-R035	DUST SDR, 35x43x5/6.5	1		
5	UPSK-Y035	PACKING U, SKY 35x45x6	1		
6	UPIS-I035	PACKING U, ISI 35x45x6	1		
7	DU03-5030	BUSHING DU, 35x39x30	1		
8	OR1B-G055	O-RING, 1BG55	2		
9	PI60-2746	PISTON, Φ60x27x46L	1		
10	OR1B-G027	O-RING, 1BG27	2		
11	UPOS-I060	PACKING U, OSI 60x50x6	2		
12	TRBR-0060	BACKUP RING, 60x50x3	2		
13	WEWR-0060	WEARING, WR 60x55x15	1		
14	NTP0-U100-C	NUT, 1-14UN	1		
15	226101-T	TUBE ASS'Y	1		
16	IA60-3565	SEAL KIT HEAD, No.3~8	1		
17	PA60-2746	SEAL KIT PISTON, No.9~13	1		

BUCKET CYLINDER ASS'Y-RH

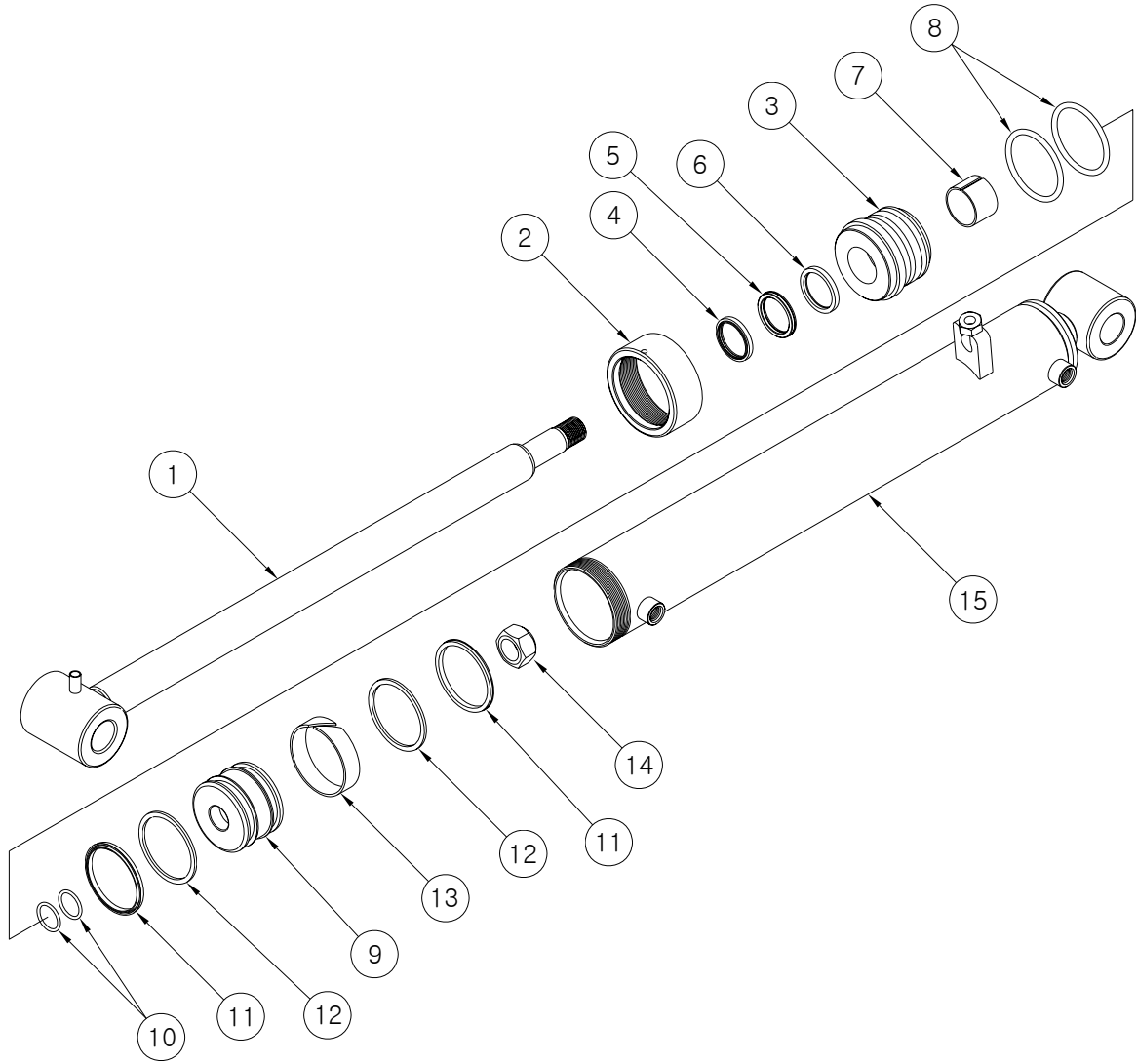



SAFETY DECALS



Warning CK12-3001
Location : Mounting Frame RH



Warning CK12-3002
Location : Mounting Frame LH



Warning CK12-3003
Location : Mounting Frame LH



Warning DEC01-M1131
Location : BOOM



DECAL, KL500, P/No: 3101E-00014
Location : BOOM



daedong

DECAL, daedong, , P/No: KTL15-S0200
Location : BOOM

Care of Safety Decals

1. Keep safety decals clean and free of obstructing material.
2. Clean safety decals with soap and water and dry with a soft cloth.
3. Replace damaged or missing safety decals with new decals from your Dealer.
4. If a component with a safety decal(s) affixed is replaced with a new part, make sure new safety decal(s) are attached in the same location(s) as the replaced components.
5. Mount new safety decals by applying on a clean dry surface and pressing air bubbles to outside edges.