

**INTAKE AND EXHAUST**

POS.	CODE	DESCRIPTION	Qty
1	7626.064	washer diam. 8,25	2
2	7625.010	washer diam. 8	1
3	7565.007	washer diam. 8	1
4	1770.004	bolt M 8 x 1,25 x 20	1
7	5460.460	exhaust muffler	1
7a	<----->	exhaust muffler	0
8	6927.367	muffler guard	1
8a	<----->	muffler guard	0
9	7625.007	washer diam. 6	4
10	9790.037	screw M 6 x 8	4
22	<----->	see Pos. A 22a	0
22a	5460.410	exhaust muffler	1
23	7565.004	washer diam. 6	2
24	<----->	nut M 6	0
26	6927.463	muffler guard	1
27	<----->	see remarks	0
27a	5460.522	exhaust muffler	1
56	<----->	see Pos.A 62 (ex 3700.377)	0
57	9580.077	breather hose	1
58	4501.124	gasket	1
59	3790.081	flange	1
60	3203.050	selflocking nut M 6	2
61	2175.172	air clean.cartridge	1
62	3700.377	DRY AIR CLEANER std	1
62	3700.378	DRY AIRCLEANER (downward type)	1
63	3700.372	OIL BATH AIR CLEANER	1
64	3200.015	wing nut	1
65	3240.004	nut M 5	2
66	4115.069	hook	2
67	9245.055	screw stay	1
68	4501.124	gasket	1
69	7565.007	washer diam. 8	2
70	3240.008	nut M 6	2
71	<----->	see Pos.A 63	0
72	5496.229	filtering element	1
73	2175.024	air clean.cartridge	2
74	1200.085	O ring 3131	1
75	<----->	see Pos.A 63	0
78	9580.077	breather hose	1
79	771R.001	washer diam. 5,3	1
80	3360.039	guard	1
81	3630.156	clamp diam.20-32	1
84	8180.193	gasket set	1
85	<----->	guard	0
86	6370.140	plate	4
87	2183.098	hinge link	2
88	<----->	O ring	0
89	4501.136	gasket	1
90	1970.436	spacer	2

**Additional Info - Engine: 1IM 359 restyling Drawing: A**

**INTAKE AND EXHAUST**

Pos.	Old part	Serv.Lett.	Notes	S.No/Date
A 25	6927.296	22012	- no longer avail. - see Pos. A 26	3812663
A 26	6927.292	22010	-	3958876
	6927.404	22025	-	7809346
A 27	5460.394	22012	- no longer avail. - see Pos. A 27a	3812663
A 27a	5460.408	22012	-	3812663
	5460.518	22025	- superseded by 5460.522	7809346
A 57		22018	- starting from shown engine s.no	4025689
A 80		22003	- starting from shown engine s.no	1237042
A 81		22003	- starting from shown engine s.no	1237042
A 85	6927.403	22025	- fitted until shown engine s.no	7809346
A 86		22010	- starting from shown engine s.no	3958876
A 87		22010	- starting from shown engine s.no	3958876
A 88		22017	- improvement must be carried out - starting from shown engine s.no	.....
A 90		22026	- starting from shown engine s.no	7838598

**B**  
**1IM**

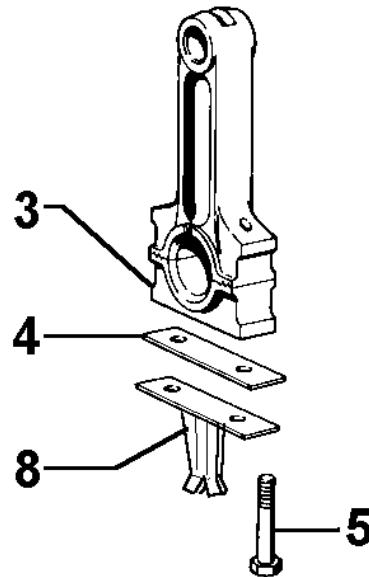
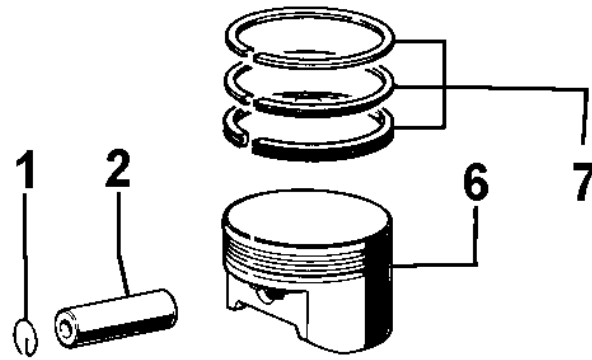

**C**  
**1IM**

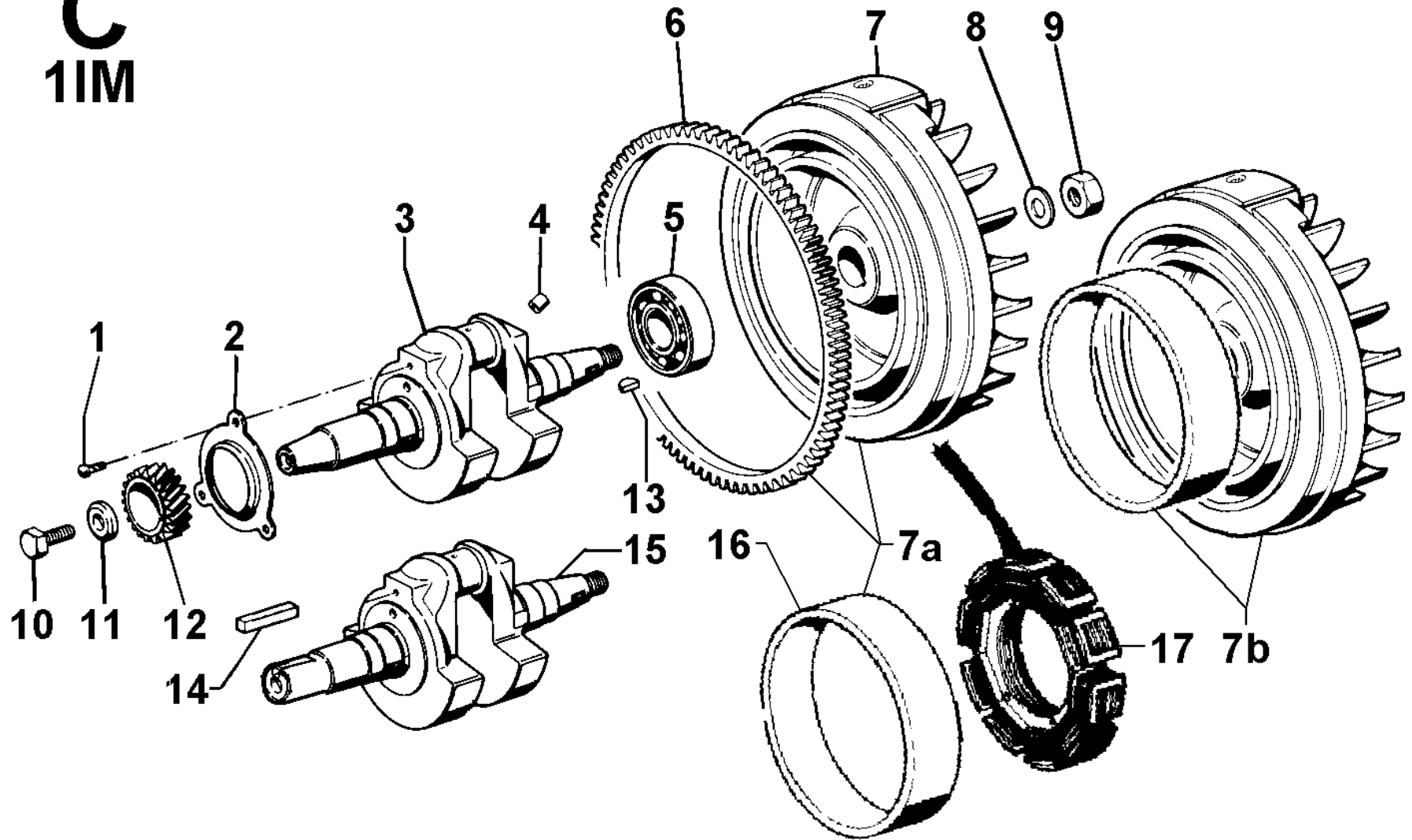



Group: 1IM  
Engine: 1IM 359 restyling Drawing: B

**CONNECTING ROD/PISTON SET**

POS.	CODE	DESCRIPTION	Qty
1	1261.070	pin ring	2
2	8480.002	gudgeon pin	1
3	1526.026	CONNECTING ROD std	1
3	1526.027	CONNECTING ROD -0,25	1
3	1526.028	CONNECTING ROD -0,50	1
4	6330.055	plate	1
5	1760.030	bolt M 6 x 45	2
6	6502.081	PISTON SET std	1
6	6502.084	PISTON SET +0,50	1
6	6502.085	PISTON SET +1,00	1
7	8211.197	ring set std.	1
7	8211.198	ring set +0,50	1
7	8211.199	ring set +1,00	1
8	5168.055	oil dipper	1





Group: 1IM  
 Engine: 1IM 359 restyling Drawing: C

**CRANKSHAFT/FLYWHEEL**

POS.	CODE	DESCRIPTION	Qty
1	<----->	nail	0
2	2194.014	oil baffle	1
3	<----->	CRANKSHAFT Ext 8 SAE J609 - no longer avail.	0
3	1051.145	CRANKSHAFT std	1
3	1051.153	CRANKSHAFT Ext 6 SAE J609	1
4	<----->	plug (no longer avail.)	0
5	3001.070	ball bearing 30x62x16	1
6	2816.034	crown gear	1
7	976A.245	flywheel	1
7a	<----->	FLYWHEEL with CROWN	0
8	7625.120	washer 19x34x3	1
9	3260.129	nut M 18 x 1,5 right	1
10	1770.039	bolt M 8 x 1,25 x 28	1
11	7625.060	washer diam. 8,4	1
12	<----->	gear	0
13	2200.022	key	1
14	2280.050	key 6,32 x 6,32 x 60	1
15	<----->	CRANKSHAFT ext 3 SAE J609 - no longer avail.	0
15	-B2A.046	CRANKSHAFT ext A3	1
16	7750.075	alternator rotor	1
17	<----->	alternator stator 12 V 10 A - 2 wires	0
17	8565.072	alternator stator 12 V 8,5 A - 3 wires	1



**Additional Info - Engine: 1IM 359 restyling Drawing: C**

**CRANKSHAFT/FLYWHEEL**

Pos.	Old part	Serv.Lett.	Notes	S.No/Date
C 3	1050.735	22023	Pos. 1- 2- 3- 4-12-13. -	7841646
C 3	1050.729	22023	Pos. 1- 2- 3- 4-12-13. -	7841646
C 3	1050.739	22023	Pos. 1- 2- 3- 4-12-13. -	7841646
C 7	9880.537	761	-	03.1990
	9880.538	22023	-	7841646
C 7a	9880.540	22023	Pos. 6- 7-16. - for electr.starting	7841646
	9881.436	22030	Pos. 6- 7-16. - for electr.starting	
C 8	7530.018	22023	-	7841646
C 9	3260.055	22023	- old type left	7841646
C 12	4936.182	22006	- fitted until shown engine s.no - for crankshafts with P.T.O. side keyhole only	3948915
C 13	2280.142	22023	-	7841646
C 15	1050.736	22023	Pos. 2- 3- 4-12-13-15. -	7841646
	1050.733	22023	Pos. 2- 3- 4-12-13-15. -	7841646
	1050.732	22023	Pos. 2- 3- 4-12-13-15. -	7841646
C 15	1050.731	22023	Pos. 2- 3- 4-12-13-15. -	7841646

# D

## 11M

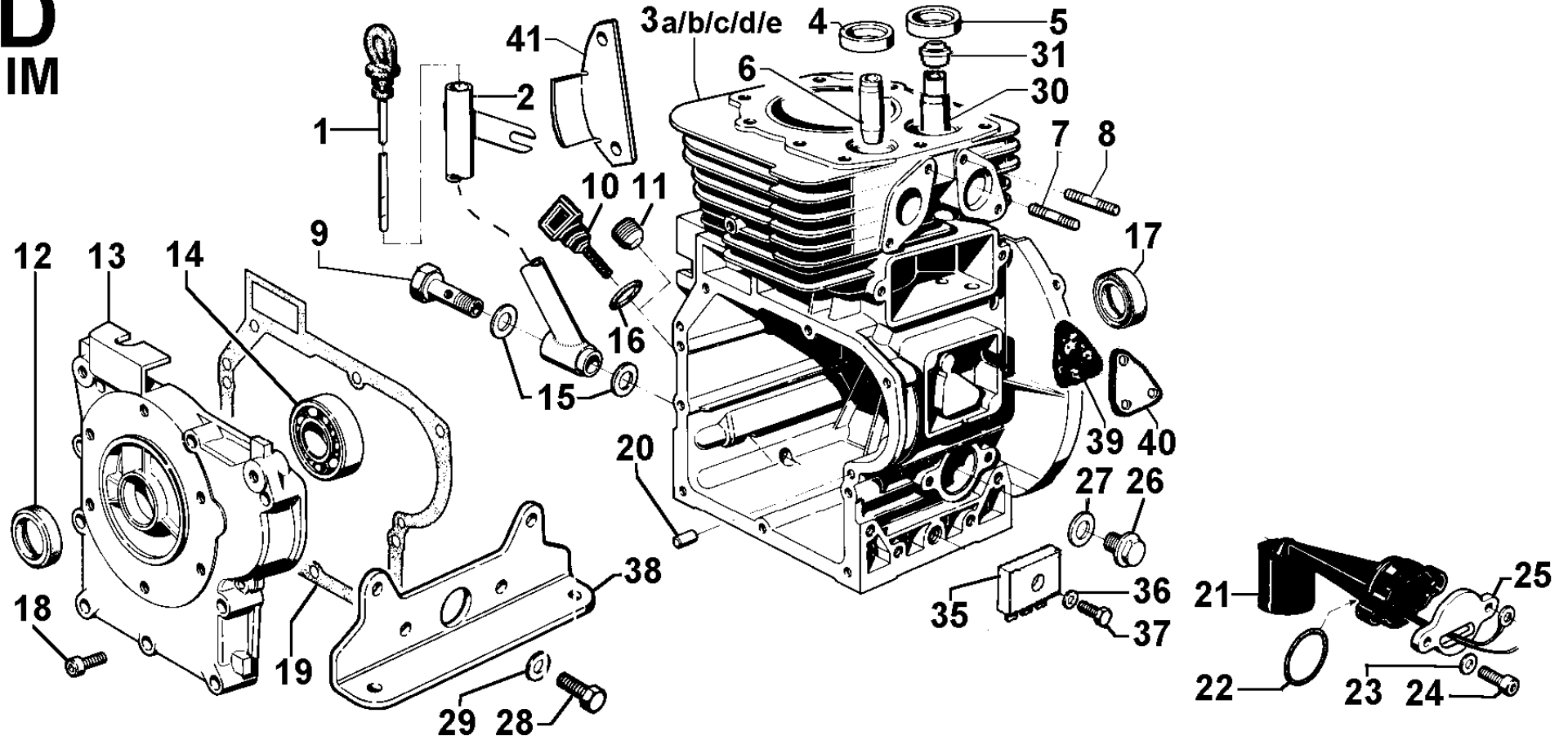



Group: 1IM  
 Engine: 1IM 359 restyling Drawing: D

**CRANKCASE/GEAR COVER/MOUNTS**

POS.	CODE	DESCRIPTION	Qty
1	1400.449	dipstick on cyl.head	1
2	9485.217	dipstick tube for el.starting	1
3	1510.788	CRANKCASE (unified - suitable for el.starting and oil-alert dev	1
3a	«-----»	CRANKCASE suitable for rewind starter only - see notes	0
4	8000.122	exhaust v.seat	1
5	8000.121	inlet v.seat	1
6	4845.028	exh. valve guide	1
7	6760.047	stud M 6 x 16	1
9	1901.014	union bolt 1/4 GAS	1
10	9032.056	dipstick	1
11	9765.058	screw M 16 x 16	1
12	1213.056	seal ring 28 x 38 x 7	1
13	6645.263	gear cover	1
14	3001.070	ball bearing 30x62x16	1
15	4350.006	gasket	2
16	1200.003	O ring 118	1
17	1213.002	seal ring 28 x 38 x 7	1
17	1213.392	seal ring 28 x 38 x 7 bidirectional	1
18	9732.060	screw M 6 x 35	9
19	4601.029	gasket	1
20	8460.083	lockpin	2
21	3440.035	oil alert device	1
22	1200.082	O ring 3106	1
23	7555.003	washer diam. 5	2
24	9730.115	screw M 5 x 14	2
25	6370.333	plate	1
26	8980.010	plug	1
27	4350.006	gasket	1
28	1770.002	bolt M 8 x 1,25 x 16	8
29	7565.007	washer diam. 8	8
30	4845.203	inlet valve guide	1
31	4535.015	valve retainer	1
38	6429.173	engine mount	2
41	3800.040	flange	1



# E

## 1IM

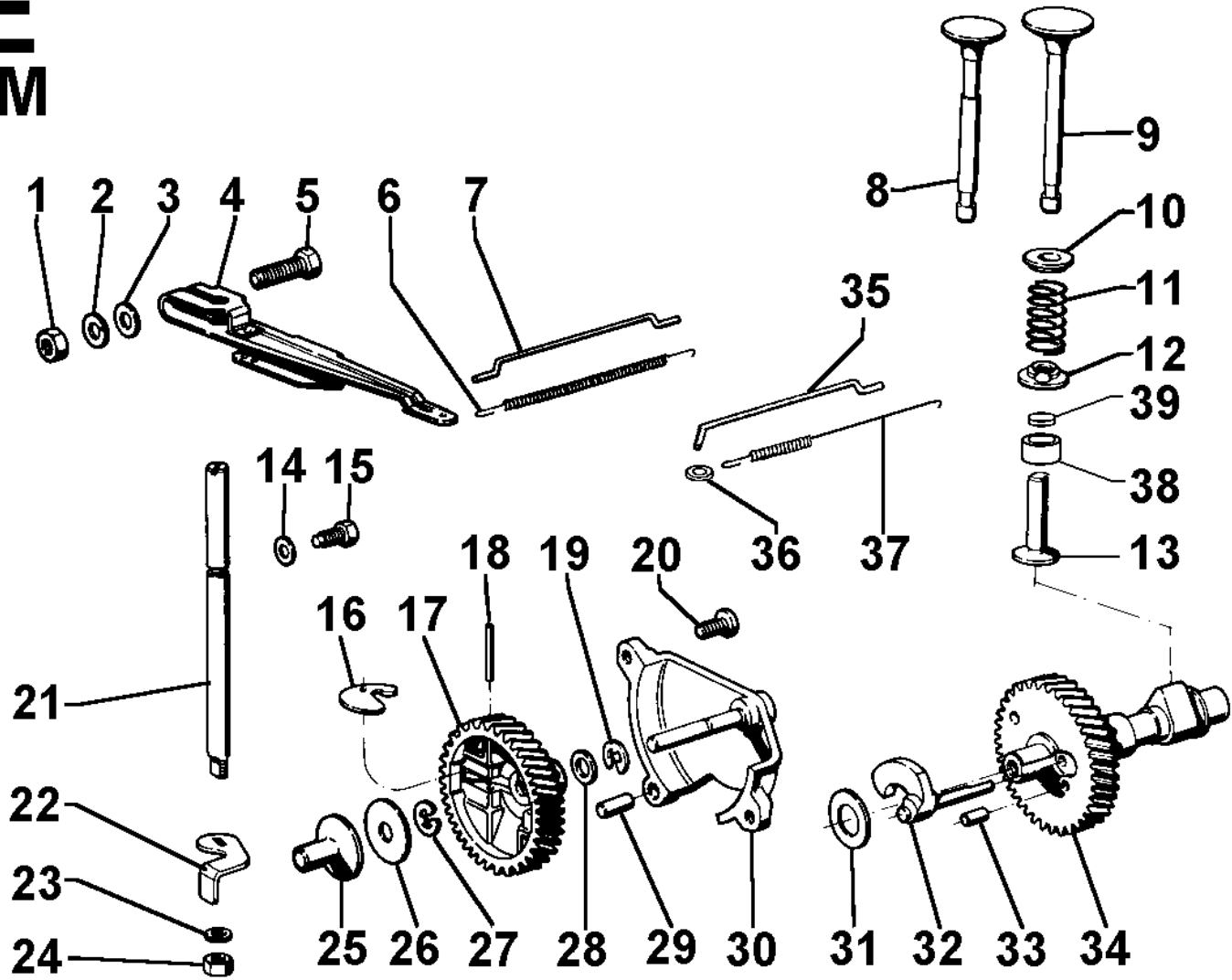

**TIMING/SPEED GOVERNOR**

POS.	CODE	DESCRIPTION	Qty
1	3240.004	nut M 5	1
2	7555.003	washer diam. 5	1
3	771R.001	washer diam. 5,3	1
4	5200.880	lever	1
5	1755.014	bolt M 5 x 25	1
8	9685.154	exhaust valve	1
9	9652.162	intake valve	1
10	6400.029	cup	2
11	5755.125	valve spring	2
12	6400.028	cup	2
13	7215.029	tappet	2
14	771R.001	washer diam. 5,3	1
15	1919.006	bolt	1
16	<----->	see Pos.E 30	0
19	1165.010	circlip	1
20	9790.047	screw M 6 x 16	3
21	6140.415	governor pin	1
22	5204.006	lever	1
23	7555.004	washer diam. 6	1
24	3240.008	nut M 6	1
25	7200.064	drive rod	1
26	<----->	spacer	0
27	1165.010	circlip	1
28	7620.017	washer	1
29	6130.050	pin	1
30	7362.235	SPEED GOVERNOR	1
31	1301.245	anello rasam d.28,8x16x0,16	1
32	1111.106	compression shaft	1
33	8430.061	lockpin 4 x 14	1
34	3348.040	CAMSHAFT automatic compression release	1
35	2183.099	hinge link	1
36	1185.059	ring	1
37	5801.560	recovery spring	1
38	2135.102	cap	2
39	8335.197	spacer 0,1	2
39	8335.198	spacer 0,2	8



**F**  
**1IM**

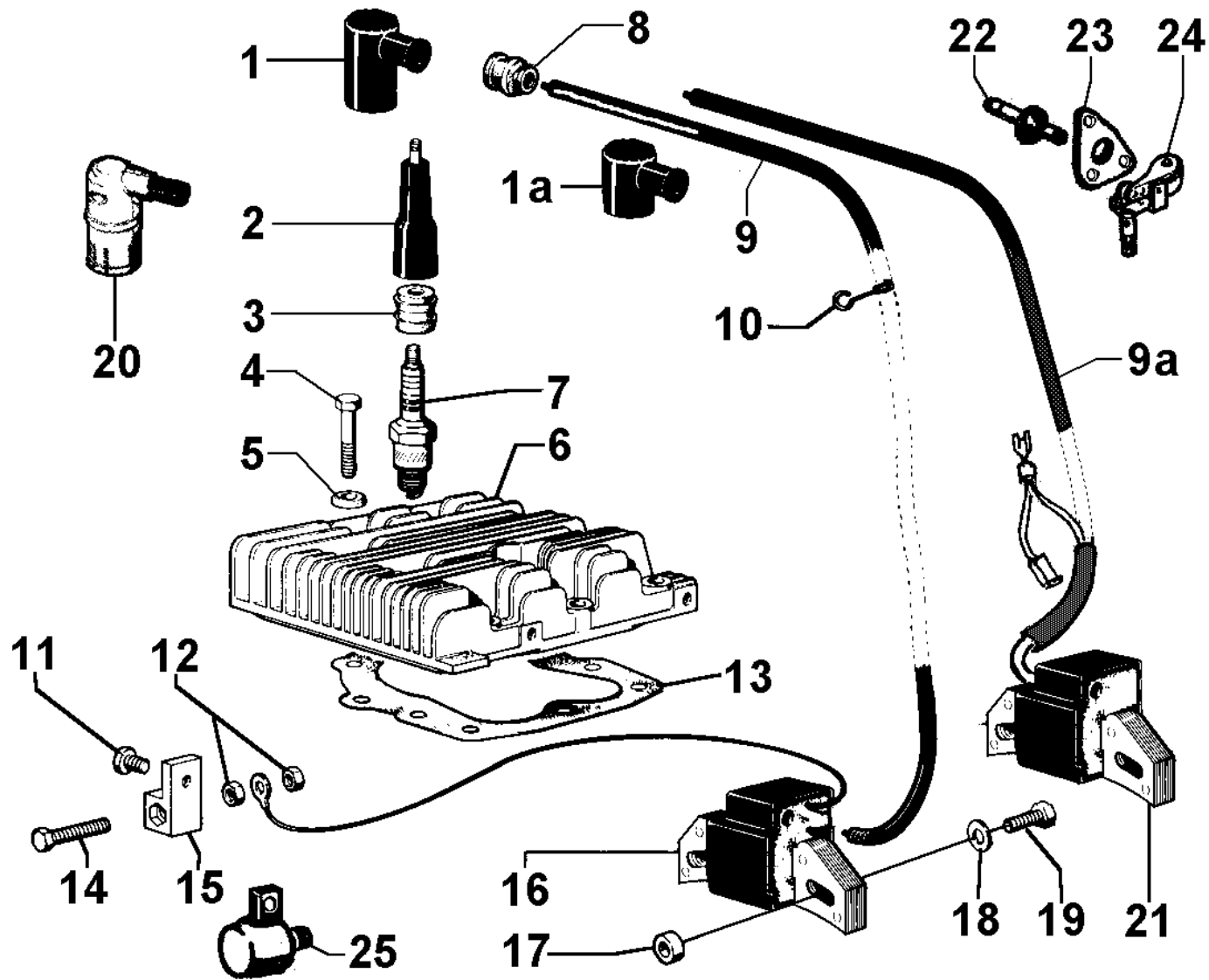





Group: 1IM  
 Engine: 1IM 359 restyling Drawing: F

**CYLINDER HEAD AND IGNITION**

POS.	CODE	DESCRIPTION	Qty
1	1450.001	spark plug cap std	1
1a	1450.128	spark plug cap	1
3	2135.049	cap	1
4	1780.128	bolt M 10x50 (2,5 Kgm)	6
4a	989A.235	bolt M 10x55 (2,5 Kgm)	3
5	7625.273	washer diam.10,5x20x5	9
6	9200.362	cilynder head	1
7	147A.131	spark plug for unloaded petrol	1
8	5400.007	sheath	1
9a	2185.943	electric wire for coil	1
10	2470.054	hink	1
13	4730.537	head gasket	1
17	<----->	spacer	0
18	7625.007	washer diam. 6	1
19	1760.006	bolt M 6 x 1 x 20	2
19	1760.008	bolt M 6 x 25	2
21	1567.220	coil std	1



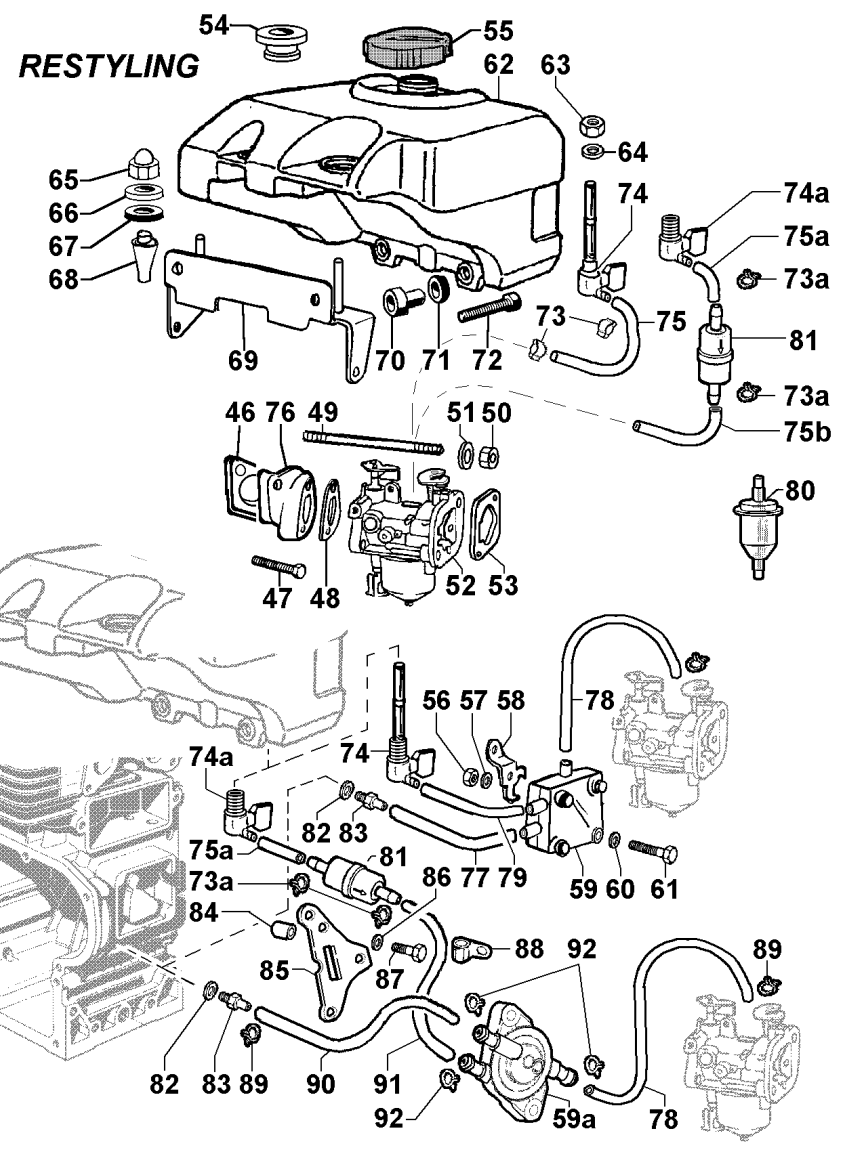
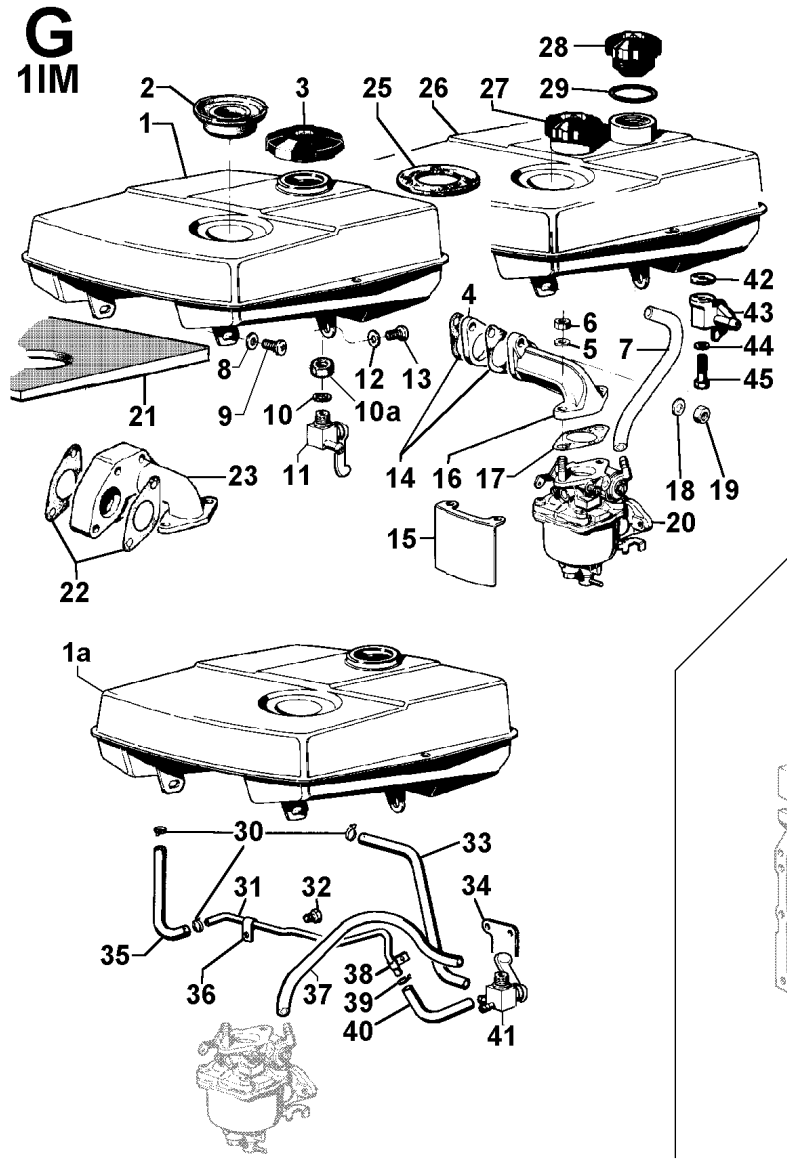

**FUEL SYSTEM**

POS.	CODE	DESCRIPTION	Qty
30	3630.057	clamp	3
46	4501.107	gasket	1
47	9732.078	screw M 6 x 25	2
48	4501.123	gasket	1
49	6760.103	stud M 6 x 85	2
50	7565.004	washer diam. 6	2
51	3240.008	nut M 6	2
52	2151.315	carburetor	1
53	4501.124	gasket	1
54	5401.110	sheath	1
55	9043.096	fuel tank cap std.	1
56	3240.004	nut M 5	1
57	7565.003	washer diam. 5	1
58	8545.575	bracket	1
59	<----->	"feed pump "WALBRO""	0
59a	6585.107	"feed pump "FRABEL""	1
60	771R.001	washer diam. 5,3	1
61	9730.096	screw M 5x40	1
62	8103.302	FUEL TANK	1
63	3240.132	nut M 10	1
64	4580.186	seal gasket	1
65	3203.050	selflocking nut M 6	2
66	7670.117	washer diam. 6,5x23	2
67	7701.154	rubber washer	8
68	3527.437	spacer	2
69	8865.183	support	1
70	3527.427	spacer	2
71	7670.117	washer diam. 6,5x23	2
72	9732.078	screw M 6 x 25	2
73	3630.057	clamp	1
73a	375A.132	clamp	2
74	<----->	shut off valve	0
74a	7755.091	shut off valve	1
75	<----->	hose	0
75	9375.196	fuel hose	1
76	3855.139	carburetor flange	1
77	9375.196	fuel hose	1
79	<----->	see Pos.G 77	0
80	3730.121	fuel filter	1
81	391A.104	fuel filter	1
82	4670.001	copper gasket diam. 6,2 x 10 x 1	1
83	7301.085	union	1
84	1970.463	sleeve	2
85	858A.334	support	1
86	771A.143	washer	2
87	1755.003	bolt	2
88	3617.015	clamp	1
89	3630.113	clamp CE 09	2
90	9375.196	fuel hose	1
92	3630.163	clamp	3

**Additional Info - Engine: 1IM 359 restyling Drawing: G**

**FUEL SYSTEM**

<b>Pos.</b>	<b>Old part</b>	<b>Serv.Lett.</b>	<b>Notes</b>	<b>S.No/Date</b>
G 52	2151.267	22019	-	4086785
	2151.267	22019	-	4086785
	2151.272	22027	-	7825912
	2151.272	22027	-	7823500
G 73a		22031	-	4968438
G 74	7755.108	22031	-	4968438
G 74a		22031	-	4968438
G 75	9375.196	22031	-	4968438
G 75a		22031	-	4968438
G 75b		22031	-	4968438
G 81		22031	-	4968438

**H**  
**1IM**

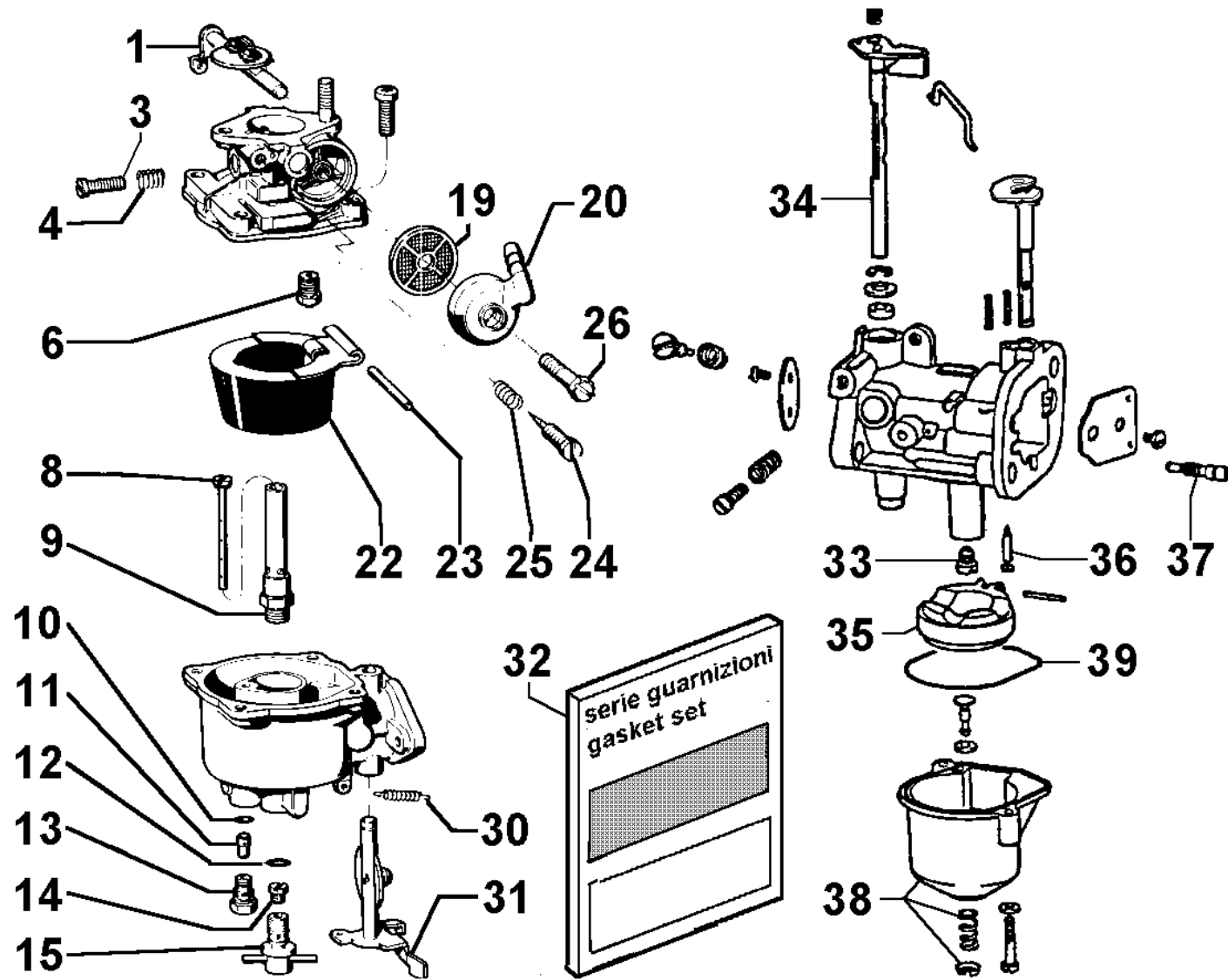



Group: 1IM  
Engine: 1IM 359 restyling Drawing: H

### CARBURETOR

POS.	CODE	DESCRIPTION	Qty
32	8180.198	carburetor gasket set	1
33	4126.082	main jet 0,80	1
34	<----->	butterfly shaft	0
35	4105.022	float	1
36	9850.127	needle valve not cushioned	1
37	4126.087	idle jet 0,40	1
38	9710.117	bowl	1
39	<----->	bowl gasket - see Pos. H 32	0





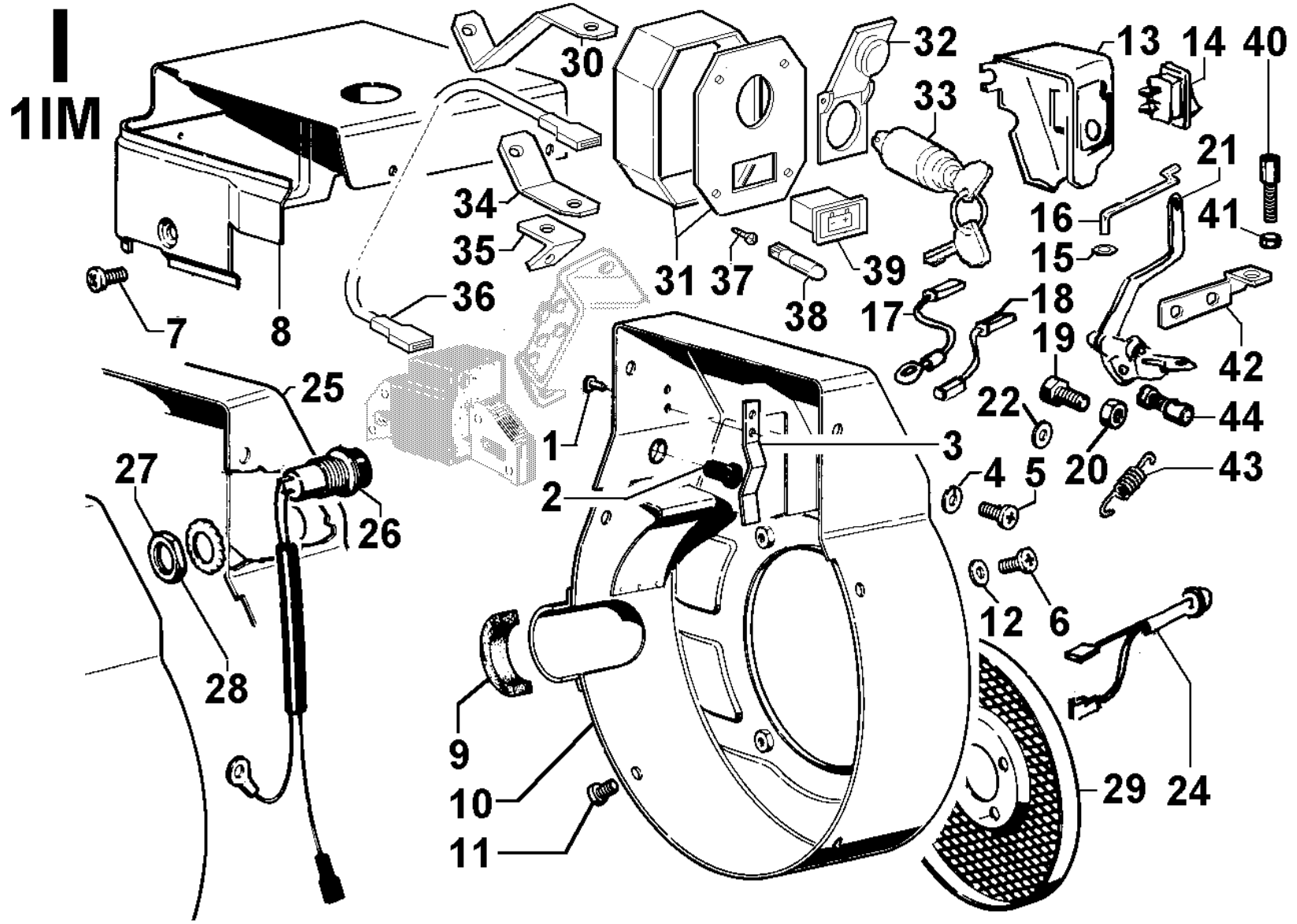

**COOLING PANELS**

POS.	CODE	DESCRIPTION	Qty
1	7481.025	nail	2
4	7500.018	washer	2
5	9790.039	screw M 6 x 12	2
8	2920.170	hood std	1
8	2920.173	hood (denoised type)	1
9	«-----»	gasket	0
10	2569.571	shroud std	1
10	2569.598	shroud (el.start.-oil alert fitted)	1
11	9790.037	screw M 6 x 8	4
12	7500.018	washer	2
13	8900.488	support	1
14	5041.260	earth push button	1
15	1185.059	ring	1
16	2183.102	hinge link	1
17	2185.921	earth electric wire	1
18	«-----»	earth electric wire - see Pos. F 9a	0
19	1760.006	bolt M 6 x 1 x 20	1
20	3203.050	selflocking nut M 6	1
21	8510.150	bracket	1
22	5715.060	washer	1
24	«-----»	oil level warning	0
30	8506.125	bracket	1
31	7245.325	DASHBOARD	1
32	2750.111	cover	1
33	«-----»	key switch - no longer avail.	0
34	8506.126	bracket	1
35	8506.127	bracket	1
36	2185.923	electric wire	1
37	«-----»	screw	0
38	5175.119	lamp 12V	1
39	«-----»	lampe socket	0
40	9180.191	adjuster M 6	1
41	3240.009	nut M 6	1
42	«-----»	brace	0
44	5830.119	nut	1

**Additional Info - Engine: 1IM 359 restyling Drawing: I**

**COOLING PANELS**

Pos.	Old part	Serv.Lett.	Notes	S.No/Date
I 14	5041.256	22024	-	7823500
I 30		22015	- starting from shown engine s.no	3851735
I 31		22015	Pos. 31-32-33-37-38-39. - starting from shown engine s .no	3851735
I 32		22015	- starting from shown engine s.no	3851735
I 33		22015	- starting from shown engine s.no	3851735
I 34		22015	- starting from shown engine s.no	3851735
I 35		22015	- starting from shown engine s.no	3851735
I 36		22015	- starting from shown engine s.no	3851735
I 37		22015	- starting from shown engine s.no	3851735
I 38		22015	- starting from shown engine s.no	3851735
I 39		22015	- starting from shown engine s.no	3851735

**L**  
**1IM**

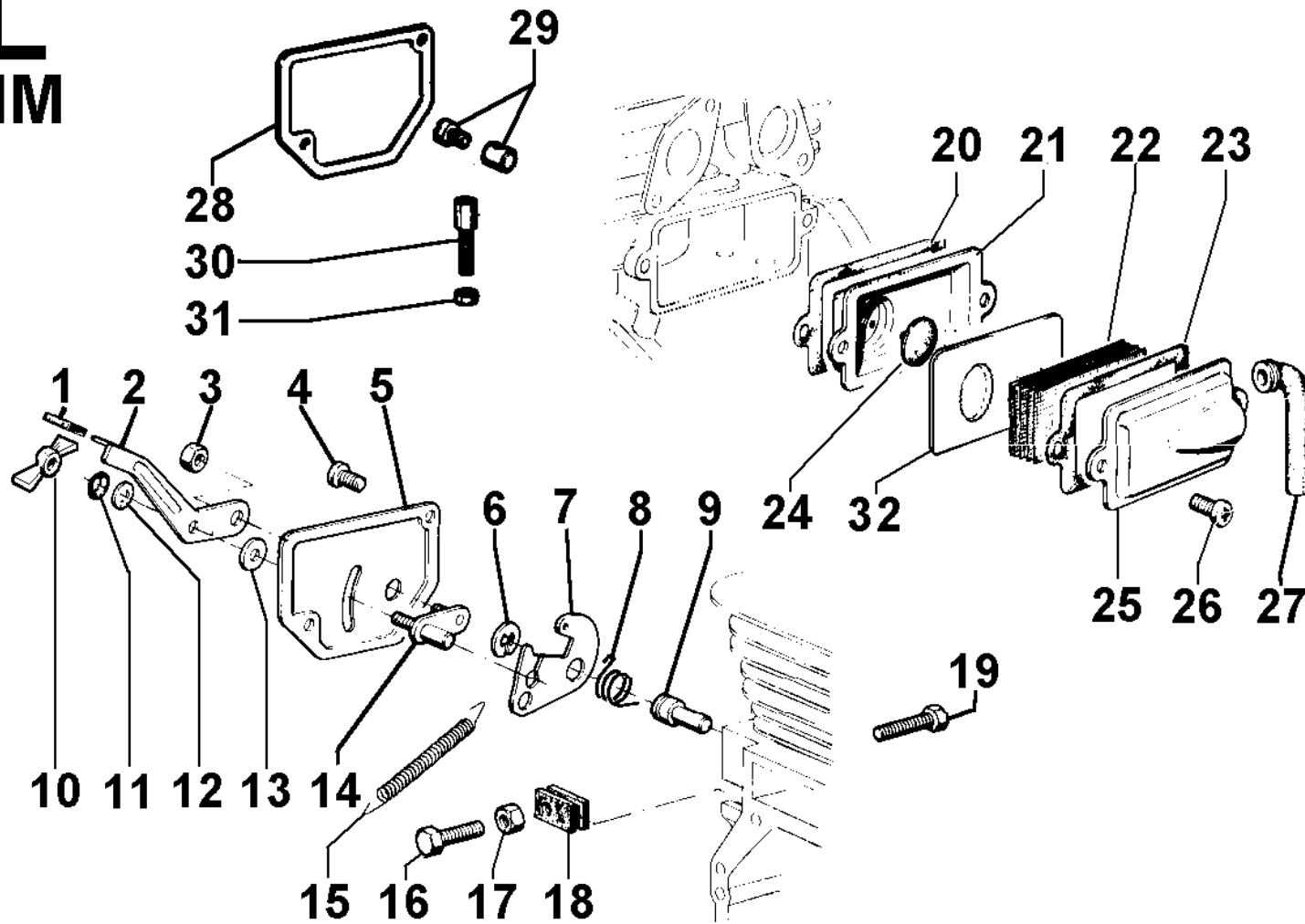

**CONTROLS**

POS.	CODE	DESCRIPTION	Qty
1	<----->	see Pos.L 5	0
2	5200.606	lever	1
3	3203.038	nut M 5x0,8	1
4	9790.028	screw M 5 x 10	2
4	9790.138	screw M 6 x 10	2
5	2750.282	hand control cover	1
6	1165.006	circlip diam. 7	1
7	5200.202	lever	1
8	5680.119	spring	1
9	6140.137	pin	1
10	3200.015	wing nut	1
11	<----->	see Pos.L 5	0
12	7626.054	washer diam. 5,3	1
13	<----->	see Pos.L 5	0
15	5655.047	governor spring std	1
15	5655.108	governor spring for generating sets 1500/3000 rpm	1
16	1760.034	bolt M 6 x 25	1
16	1760.086	bolt M 6x30	1
17	3240.008	nut M 6	1
19	1760.082	bolt M 6 x 35	1
20	4680.039	gasket	1
21	7951.109	BREATHER BOx	1
22	5976.005	filtering element	1
23	4680.039	gasket	1
24	9695.013	breather valve	1
25	2690.288	breather cap (denoised type)	1
26	9790.039	screw M 6 x 12	1
27	<----->	breather line	0
28	2691.051	remote control cover	1
29	5830.119	nut	1
30	9180.191	adjuster M 6	1
31	3240.009	nut M 6	1
32	3360.050	baffle plate	1



**M**  
**1IM**

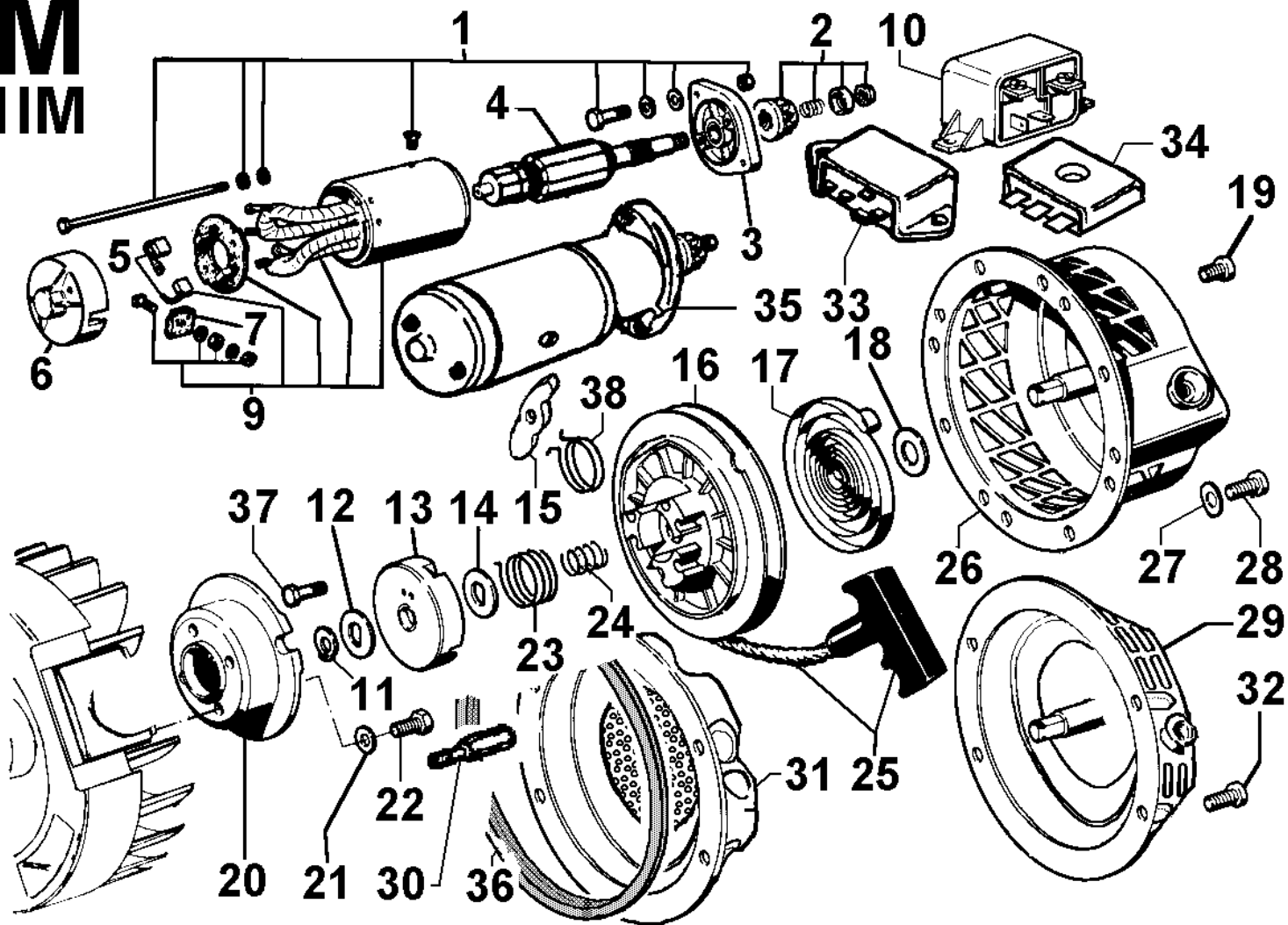



Group: 1IM  
 Engine: 1IM 359 restyling Drawing: M

**STARTING**

POS.	CODE	DESCRIPTION	Qty
1	8140.097	spare part set	1
2	6456.009	pinion gear	1
3	<----->	support - see remarks	0
5	8310.043	brush set	1
6	<----->	support	0
10	5041.019	relay	1
11	<----->	circlip	0
13	7980.063	cup	1
15	5025.097	tooth	2
16	7100.377	recoil pulley	1
17	5801.539	spiral spring	1
20	6961.109	pulley	1
21	<----->	washer diam. 6	0
23	5660.066	recovery spring	1
24	5590.026	thrust spring	1
25	4904.038	handle ass.y	1
29	1472.057	REWIND STARTING	1
30	2501.158	hollowstud	4
31	6927.358	grass guard	1
32	9730.309	screw M 6 x 8	4
33	7362.255	voltage regul.12 V 12 A	1
33	7362.298	voltage regul.12 V max 30 A - 5 contacts for alt.2 wires	1
34	7362.232	light.alt.regul.-5 contacts for alt. 3 wires	1
35	5840.119	starting motor	1
36	4570.034	gasket	1
37	9730.340	screw M 5 x 10	1
38	<----->	tooth recovery spring	0





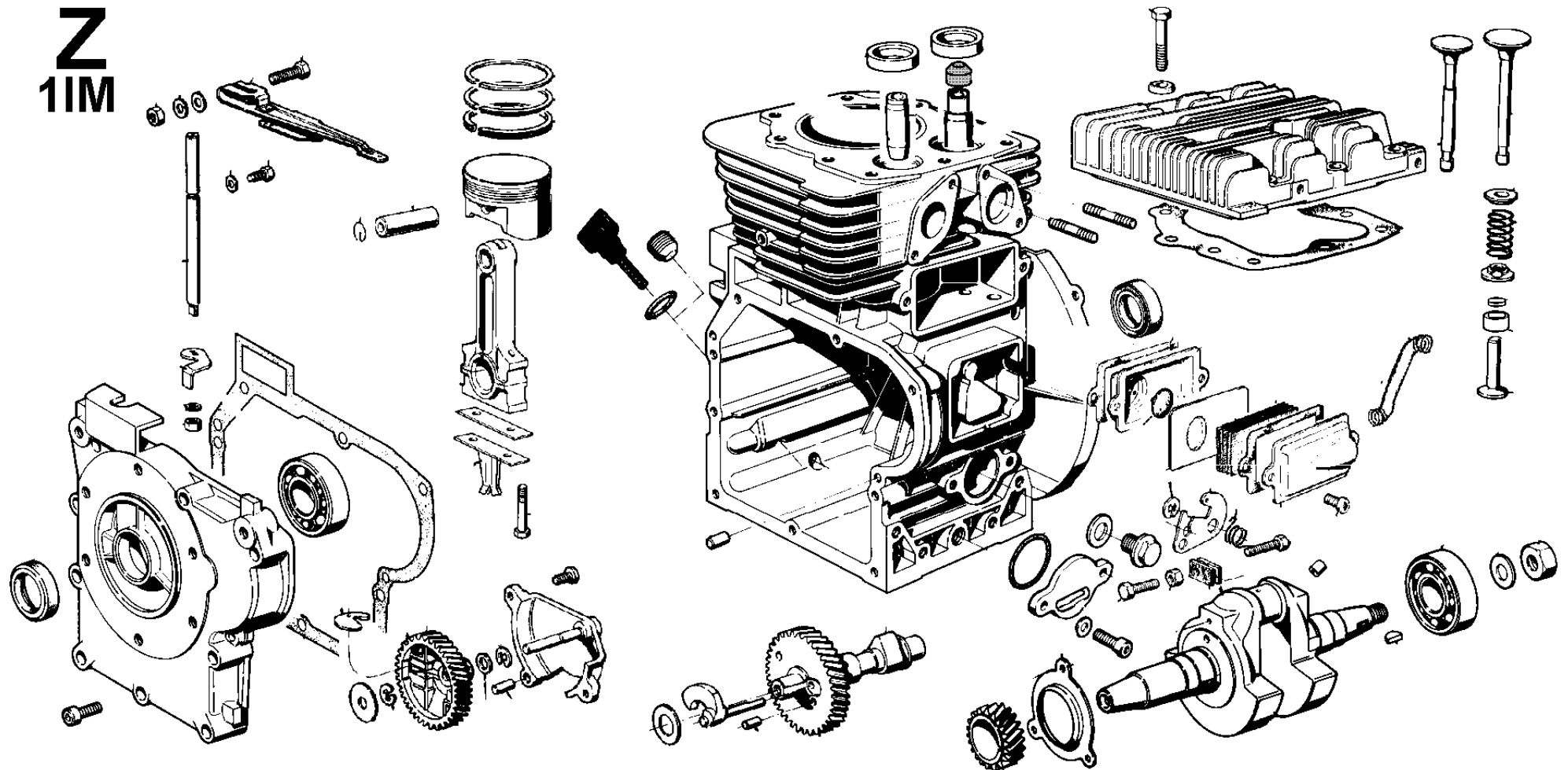



Group: 1IM  
Engine: 1IM 359 restyling Drawing: Z

**SHORT BLOCK**

POS.	CODE	DESCRIPTION	Qty
1	1560.315	short block fitted for el.start and oil-alert device - conical	1

