

**CRANKCASE/CYLINDER HEAD/GEAR COVER/COOLING PANELS**

POS.	CODE	DESCRIPTION	Qty
01	9730.384	screw M 10x100	4
02	9730.010	screw M 6 x 16	4
03	2125.332	cover	1
04	588A.228	panel	1
04a	4775.601	panel gasket	1
05	«-----»	lifting eye	0
06	1760.130	bolt M 6 x 1 x 12	2
07	«-----»	shroud	0
07a	5066.322	plate	1
08	1760.130	bolt M 6 x 1 x 12	2
10	5801.559	plate	2
11	296A.185	panel std.	1
12	5801.559	plate	1
13	8580.022	support	1
14	«-----»	gasket	0
14a	1200.369	O ring	1
15	7625.281	washer	4
16	676R.003	stud	1
17	6780.173	stud	1
18	1760.130	bolt M 6 x 1 x 12	4
19	3527.432	hollowstud	1
20	296A.181	panel std.	1
21	«-----»	see remarks	0
22	3630.162	clamp	1
23	1760.130	bolt M 6 x 1 x 12	1
24	1200.293	ring	1
25	8965.077	plug M 22	1
26	2165.135	deflector	1
27	1760.130	bolt M 6 x 1 x 12	2
29	994A.002	bolt M 6 x 1 x 20	3
30	«-----»	CYLINDER HEAD	0
31	4730.619	gasket	1
32	4601.174	gasket	1
33	1970.418	sleeve	2
34	1510.778	CRANKCASE std and for el.starting	1
35	1760.130	bolt M 6 x 1 x 12	4
36	3527.433	hollowstud	1
37	3527.504	hollowstud	1
38	7701.189	washer	1
39	9040.025	magnetic discharging oil plug	1
40	8180.195	GASKET SET	1
41	1760.130	bolt M 6 x 1 x 12	3
42	9732.063	screw M 8 x 35	7
43	7645.006	washer diam. 8	7
44	9730.032	screw M 8 x 45	2
45	7645.006	washer diam. 8	2
46	6645.597	GEAR COVER	1
47	1970.419	sleeve	2
48	1400.282	dipstick	1
49	5981.087	panel for key switch	1
50	7645.005	washer diam. 6	1
56	5096.091	flywheel guard	1
59	7300.101	union	1

**Group: LGA 280-340**

**Engine: LGA 280 Drawing: A**

**CRANKCASE/CYLINDER HEAD/GEAR COVER/COOLING PANELS**

POS.	CODE	DESCRIPTION	Qty
62	9580.075	breather hose	1
63	3630.161	clamp	2
64	1200.350	dipstick seal ring	2
65	6300.032	plate	1

**Additional Info - Engine: LGA 280 Drawing: A**

**CRANKCASE/CYLINDER HEAD/GEAR COVER/COOLING PANELS**

Pos.	Old part	Serv.Lett.	Notes	S.No/Date
A 04	5995.013	tdt 2778-		10.2002
A 14	4701.103	25015	-	4885451
A 14a		25015	-	4885451
A 21	5981.081	25001	- fitted until shown engine s.no	7500672
A 24	1200.293	25009	-	7505896
	1200.295	25010	-	7506395
A 25	8965.077	25009	-	7505896
	8965.081	25010	- old type is M 15	7506395
A 34	1510.777	25008	Pos. A24-A25-A34-A38-A39-B32-D28-D29-D31 - old type unified with the one suitable to el.starting (70 or 180 W)	7505896
A 37	3527.434	25006	-	7504983
A 46	6645.554	25004	Pos. A46-D38 -	7501500
	6645.590	25008	Pos. A46-D38 -	7505896
A 49		25001	- starting from shown engine s.no	7500673
	5981.083	25006	-	7504983
A 50		25001	- starting from shown engine s.no	7500673
A 65		25014	-	7511524

**B**  
LGA  
280  
340

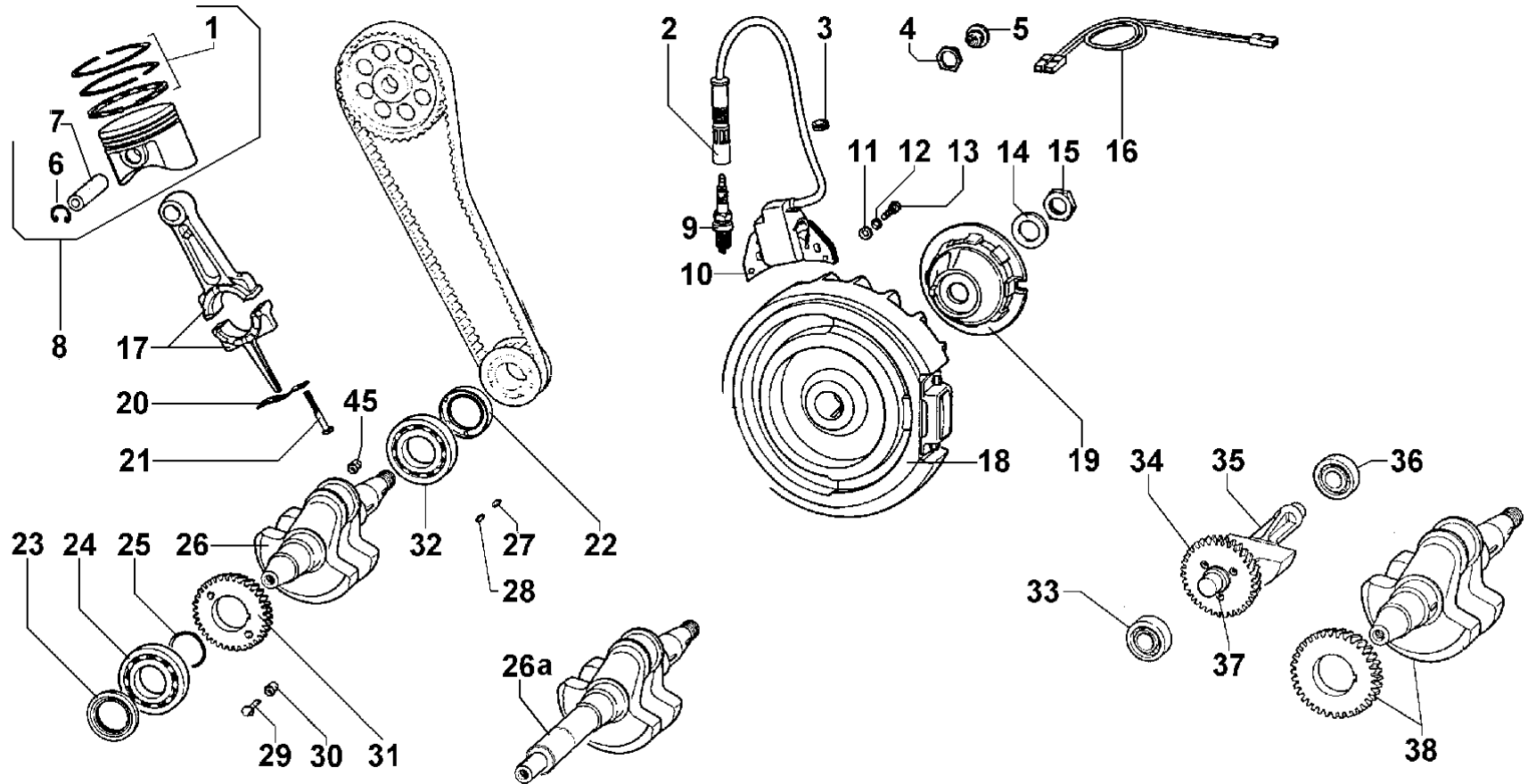

CONN.ROD/PISTON/CRANKSHAFT/FLYWHEEL/IGNITION

POS.	CODE	DESCRIPTION	Qty
01	8211.236	ring set std.	1
01	8211.237	ring set +0,50	1
01	8211.238	ring set +1,00	1
02	2145.063	spark plug cable with cap	1
03	5830.169	cable-sleeve	1
04	<----->	see remarks	0
06	1160.059	circlip	2
07	8480.097	gudgeon pin	1
08	6501.945	piston set std	1
08	6501.946	piston set +0,50	1
08	6501.947	piston set +1,00	1
09	2100.067	spark plug	1
10	1567.240	coil	1
11	7625.008	washer diam. 6,4	2
12	7645.005	washer diam. 6	2
13	9732.078	screw M 6 x 25	2
14	7625.120	washer 19x34x3	1
15	3260.023	nut M 18	1
16	2185.920	wire	1
17	1526.185	connecting rod std.	1
17	1526.190	connecting rod -0,25	1
17	1526.191	connecting rod -0,50	1
18	9881.515	flywheel std.	1
19	6961.109	pulley	1
20	5168.064	safety plate	1
21	995A.048	bolt	2
22	054R.052	seal ring 30x47x7	1
24	3002.080	ball bearing 30x72x19	1
25	1301.333	lockwasher	1
26	1050.949	CRANKSHAFT	1
27	2200.022	key	1
29	<----->	see pos. B 26	0
32	3002.080	ball bearing 30x72x19	1

**Additional Info - Engine: LGA 280 Drawing: B**

**CONN.ROD/PISTON/CRANKSHAFT/FLYWHEEL/IGNITION**

Pos.	Old part	Serv.Lett.	Notes	S.No/Date
B 04	3300.230	25001	- fitted until shown engine s.no	7500672
B 05	7195.132	25001	- fitted until shown engine s.no	7500672
B 08	6501.408	mat 5367	Pos. B01-B06-B07-B08 -	
B 08	6501.409	mat 5367	Pos. B01-B06-B07-B08 -	
B 08	6501.410	mat 5367	Pos. B01-B06-B07-B08 -	
B 09	2100.079	IT0124	- substitution	
B 10	1567.218	25017	- substitution	5429680
	1567.218	25017	- substitution	5429680
B 18	9881.193	25017	- not suitable for light alternator fitting	5429680
B 24	3001.070	25008	- old type ex 3001.009	7505896
B 32	3001.070	25008	- old type superseded by 3001.009	7505896

**C**  
**LGA**  
**280**  
**340**

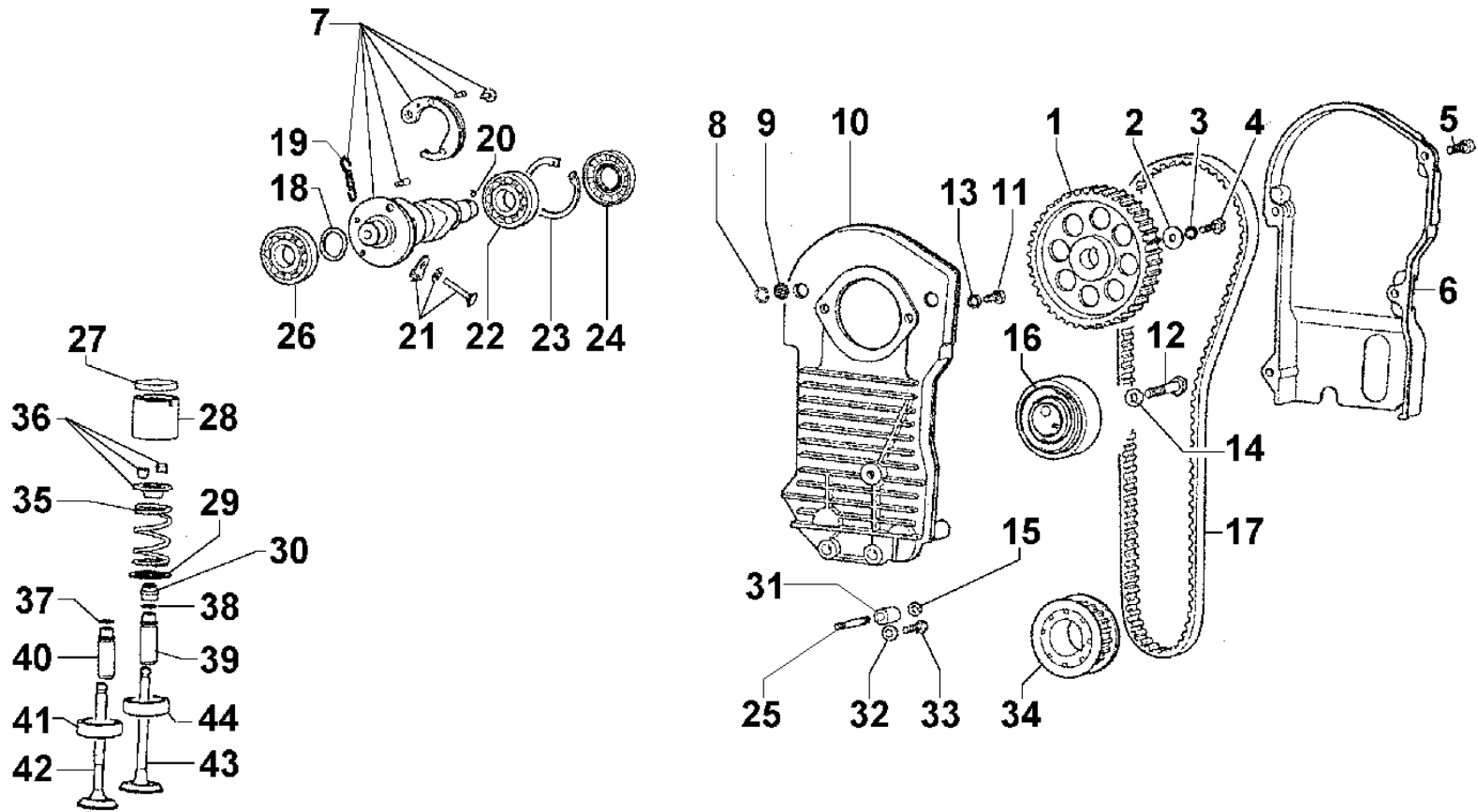



**TIMING/CAMSHAFT/VALVES**

POS.	CODE	DESCRIPTION	Qty
01	6975.330	belt pulley	1
02	7625.286	washer	1
03	7645.005	washer diam. 6	1
04	1760.006	bolt M 6 x 1 x 20	1
05	9730.012	screw M 6 x 20	4
06	2165.083	belt guard	1
07	1011.756	camshaft with compression release	1
08	1160.060	lockwasher	2
09	«-----»	strainer	0
10	2165.131	GEAR COVER	1
11	1760.005	bolt M 6 x 1 x 16	2
12	1770.014	bolt M 8 x 45	1
13	7645.005	washer diam. 6	2
14	7645.006	washer diam. 8	1
15	3203.050	selflocking nut M 6	1
16	4898.054	jockey	1
17	2440.346	timing belt	1
18	1301.334	lockwasher	1
19	«-----»	compression spring	0
20	7770.175	roller diam. 4 x 5	1
21	«-----»	see Pos. C 07	0
22	3001.069	ball bearing 17x40x12	1
23	1240.039	snap ring i.d.40	1
24	1213.356	seal ring 17x40x7	1
25	«-----»	stud	0
26	3001.069	ball bearing 17x40x12	1
27	8335.227	spacer 3,80	2
27	8335.229	spacer 3,90	2
27	8335.230	spacer 3,95	2
27	8335.231	spacer 4,00	2
27	8335.232	spacer 4,05	2
27	8335.233	spacer 4,10	2
27	8335.234	spacer 4,15	2
27	8335.235	spacer 4,20	2
27	8335.236	spacer 4,25	2
28	7215.136	push rod	2
29	6400.083	cup	2
30	4535.015	valve retainer	2
31	3527.430	spacer	1
32	7625.008	washer diam. 6,4	1
33	1760.034	bolt M 6 x 25	1
34	6975.365	drive pulley	1
35	5755.146	valve spring	2
36	6400.084	retainer with half-collets	2
37	1160.058	lockwasher	1
39	4845.264	valve guide	1
41	8000.210	exhaust v.seat	1
42	9685.143	exhaust valve	1
43	9652.150	intake valve	1
44	8000.209	inlet v.seat	1

**Additional Info - Engine: LGA 280 Drawing: C**

**TIMING/CAMSHAFT/VALVES**

<b>Pos.</b>	<b>Old part</b>	<b>Serv.Lett.</b>	<b>Notes</b>	<b>S.No/Date</b>
C 34	6975.329	25016	-	7515262

# D

LGA  
280  
340

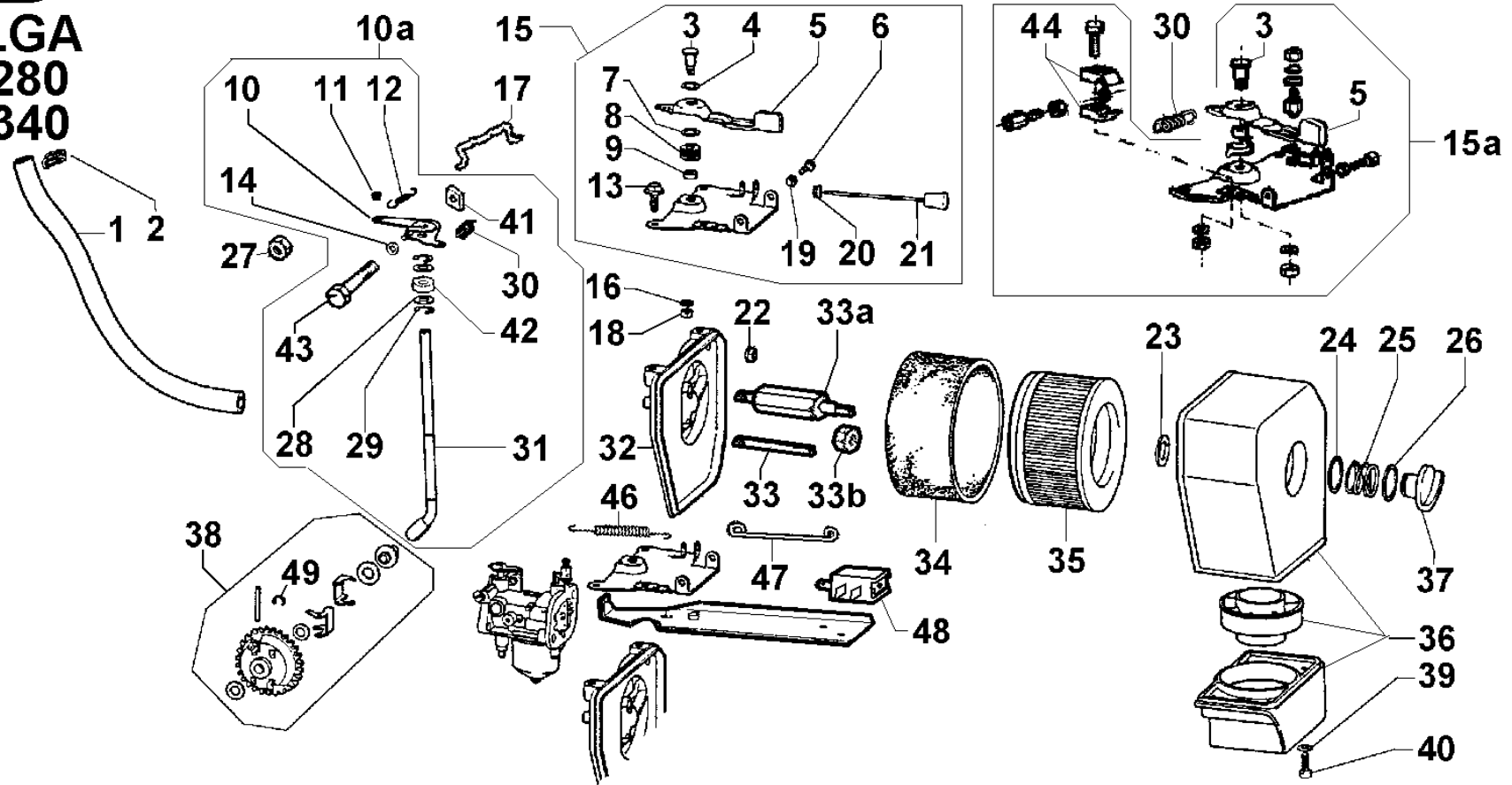

**CONTROLS/SPEED GOVERNOR/AIR CLEANER**

POS.	CODE	DESCRIPTION	Qty
01	9580.075	breather hose	1
02	3630.161	clamp	2
03	<----->	pin	0
04	7520.012	washer	1
05	5200.956	control lever	1
06	1755.020	screw	2
07	7520.012	washer	1
08	5801.570	spring	4
09	3527.489	spacer	1
10	<----->	see Pos. D 10a	0
12	5670.020	spring	1
13	1760.130	bolt M 6 x 1 x 12	2
14	771R.001	washer diam. 5,3	1
15	2690.353	HAND CONTROL	1
15a	2690.354	REMOTE ACCEL. CONTROL	1
16	7625.008	washer diam. 6,4	1
17	<----->	see Pos. E 11	0
18	3240.008	nut M 6	1
19	3240.004	nut M 5	2
20	5830.168	cable-sleeve	1
21	3695.083	governor cable	1
22	3203.050	selflocking nut M 6	2
23	7701.190	washer	1
24	7520.013	washer	1
25	<----->	spring	0
26	7520.013	washer	1
27	<----->	see remarks	0
28	7520.012	washer	2
29	1165.006	circlip diam. 7	2
30	551A.165	spring 3600 R.P.M.	1
30	551A.166	spring 3000 R.P.M.	1
31	1415.053	governor rod	1
32	8741.157	AIR FILTER SUPPORT	1
33	<----->	stud	0
33a	989A.248	special stud	1
33b	<----->	nut M 6 - no longer avail.	0
34	5496.338	filtering element	1
35	2175.240	AIR CLEANER CARTRIDGE	1
36	231A.276	cover without prefilter	1
36a	670A.112	olt type with cyclonic prefilter	1
36b	670A.113	deflector	1
37	6560.036	knob	1
38	7362.310	speed governor	1
40	997A.218	screw M 4,8 x 19	4
41	3300.245	nut M 5	1
42	1213.391	seal ring for inj.pump rack	1
43	<----->	bolt M 5 x 25 - see Pos. D 10a	0
44	5830.179	clamp	2
46	5670.019	spring	1
47	<----->	tie rod	1
48	3586.061	electro-magnet ( device)	1
49	046A.125	snap ring	1
54003	3360.060	inlet strainer (Secma)	1

**Additional Info - Engine: LGA 280 Drawing: D**

**CONTROLS/SPEED GOVERNOR/AIR CLEANER**

Pos.	Old part	Serv.Lett.	Notes	S.No/Date
D 10	5200.943	25005	-	7503872
D 11	1585.200	25005	- fitted until shown engine s.no	7503872
D 12	5670.019	25004	-	7501500
D 27	3203.038	25004	- fitted until shown engine s.no	7501500
D 30	5801.569	25004	-	7501500
	5801.589	25005	-	7503872
	5801.591	25012	-	7510393
D 30	5801.569	25004	-	7501500
	5801.588	25005	-	7503872
	5801.590	25012	-	7510361
D 31	1415.047	25004	-	7501500
D 33	6760.105	25013	-	7508901
D 33a		25013	-	7508901
D 41		25004	- starting from shown engine s.no	7501500
D 42		25004	- starting from shown engine s.no	7501500
D 43		25004	- starting from shown engine s.no	7501500

# E

LGA  
280  
340

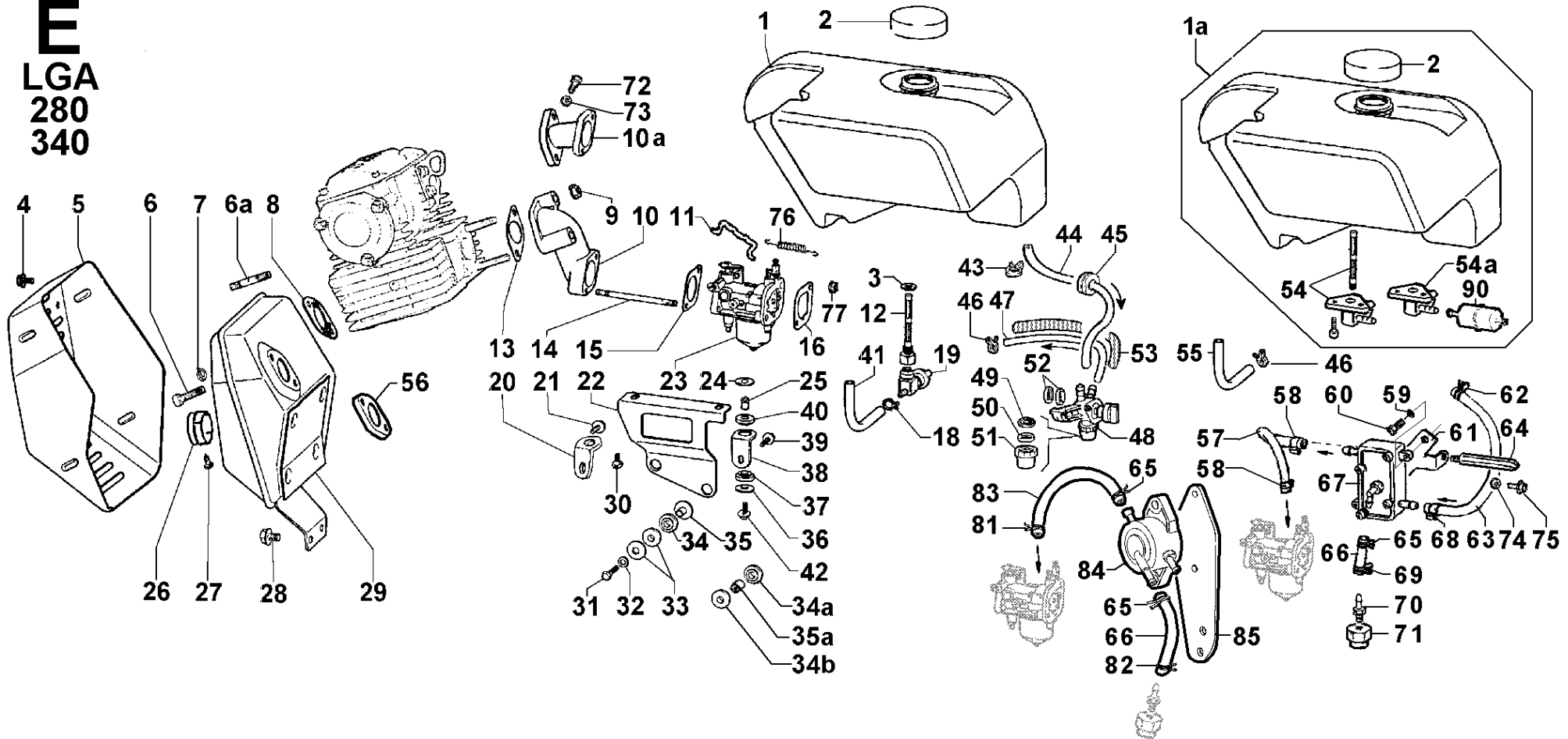

FUEL TANK/EXHAUSTING MUFFLER/CARBURETOR

POS.	CODE	DESCRIPTION	Qty
01	<----->	see remarks	0
01a	8103.309	FUEL TANK ASS.Y	1
02	9043.086	gasoline tank cap	1
03	<----->	see remarks	0
04	1760.130	bolt M 6 x 1 x 12	4
05	6927.395	guard	1
06	9732.064	screw M 8 x 30	2
07	7645.006	washer diam. 8	2
08	4501.122	exhaust gasket	1
09	3240.164	nut M 8	2
10	2942.179	inlet elbow	1
11	9235.041	tie rod	1
12	<----->	see remarks	0
13	4420.073	gasket	1
14	6760.106	stud	2
15	4501.123	carburetor gasket	1
16	4501.124	gasket	1
18	<----->	see remarks	0
20	8865.194	brace	1
21	1760.130	bolt M 6 x 1 x 12	1
22	8865.195	support	1
23	2151.300	carburetor FHBC 25/21 max 84	1
24	7626.051	washer diam. 6,2	2
25	1970.416	sleeve	2
26	<----->	spark arrester - no longer avail.	0
27	9790.142	screw	1
28	1770.159	bolt	2
29	5460.488	exhaust muffler	1
30	1760.130	bolt M 6 x 1 x 12	2
31	1760.034	bolt M 6 x 25	2
32	7645.005	washer diam. 6	1
33	7626.051	washer diam. 6,2	2
34	<----->	vibration-damping - see Pos. E 34a+E34b+E35a	0
34a	8636.197	vibration-damping	2
34b	8636.198	vibration-damping	2
35	3527.431	spacer	2
35a	1970.436	spacer	2
36	7626.051	washer diam. 6,2	2
37	8636.147	vibration-damping	1
38	8865.194	brace	1
39	994A.002	bolt M 6 x 1 x 20	1
40	<----->	vibration-damping - see Pos. E 34a+E34b+E35a	0
42	994A.002	bolt M 6 x 1 x 20	1
43	<----->	see remarks	0
44	9376.095	see remarks	1
45	1261.104	ring	1
46	3630.167	clamp	2
47	<----->	see remarks	0
52	4670.001	see remarks	0
53	<----->	see remarks	0
55	9375.719	fuel hose	1
56	3825.053	exhaust flange	1
57	9375.196	fuel hose	1

Group: LGA 280-340

Engine: LGA 280 Drawing: E

FUEL TANK/EXHAUSTING MUFFLER/CARBURETOR

POS.	CODE	DESCRIPTION	Qty
58	3630.050	clamp	2
59	7645.005	washer diam. 6	2
60	1760.003	bolt M 6 x 1 x 12	2
61	8545.764	bracket	1
62		clamp	2
65	3630.113	clamp CE 09	2
66	9375.196	fuel hose	1
67	6585.106	feed pump	1
68		clamp	1
69	3630.057	clamp	1
70	«-----»	see Pos. A 59	0
71	8965.086	plug M 22	1
74	7625.008	washer diam. 6,4	1
75	1760.130	bolt M 6 x 1 x 12	1
77	3203.050	selflocking nut M 6	2
81	3630.185	clamp	1
82	3630.163	clamp	1
83	9375.196	fuel hose	1
84	6585.107	"feed pump "FRABEL""	1
85	6360.157	plate	1
90	391A.104	fuel filter	1



**Additional Info - Engine: LGA 280 Drawing: E**

**FUEL TANK/EXHAUSTING MUFFLER/CARBURETOR**

Pos.	Old part	Serv.Lett.	Notes	S.No/Date
E 01	8103.299	25001	Pos. E01-E02 - fitted until shown engine s.no - then s	7500673
	8103.301	25006	ee Pos. E 01a Pos. E01-E02 - fitted until shown engine s.no - then s	7504983
			ee Pos. E 01a	7504983
E 01a		25006	Pos. E01-E02-E54 - starting from shown engine s.no	7504983
E 03	4775.536	25001	- fitted until shown engine s.no	7500672
E 11	9235.027	25005	-	7503872
E 12	3730.097	25001	- fitted until shown engine s.no	7500672
E 18	3630.163	25001	- fitted until shown engine s.no	7500672
E 19	7755.107	25001	- fitted until shown engine s.no	7500672
E 20	8865.184	25006	-	7504983
E 22	8865.185	25006	-	7504983
E 23	2151.266	25004	-	7501500
	2151.284	25005	-	7503872
	2151.286	25011	-	7510611
E 38	8865.184	25006	-	7504983
E 41	9375.196	25001	- fitted until shown engine s.no - old type superseded by 9375.196	7500672
E 43		25001	- starting from shown engine s.no	7500673
	3630.168	25006	- fitted until shown engine s.no	7504983
E 44		25001	- starting from shown engine s.no	7500673
E 44	934A.117	25006	- fitted until shown engine s.no	7504983
E 45		25001	- starting from shown engine s.no	7500673
E 46		25001	- starting from shown engine s.no	7500673
E 47	9375.952	25001	- starting from shown engine s.no	7500673
	9375.952	25006	- fitted until shown engine s.no	7504983
E 48		25001	- starting from shown engine s.no	7500673
	7755.111	25006	- fitted until shown engine s.no	7504983
E 49		25001	- starting from shown engine s.no	7500673
	3750.103	25006	- fitted until shown engine s.no	7504983
E 50		25001	- starting from shown engine s.no	7500673
	1261.105	25006	- fitted until shown engine s.no	7504983
E 51		25001	- starting from shown engine s.no	7500673
	9710.115	25006	- fitted until shown engine s.no	7504983
E 52		25001	- starting from shown engine s.no	7500673
	3527.478	25006	- fitted until shown engine s.no	7504983
E 53		25001	- starting from shown engine s.no	7500673
	4340.084	25006	- fitted until shown engine s.no	7504983
E 54		25006	- starting from shown engine s.no	7504983
E 55		25006	- starting from shown engine s.no	7504983

**F**  
**LGA**  
**280**  
**340**

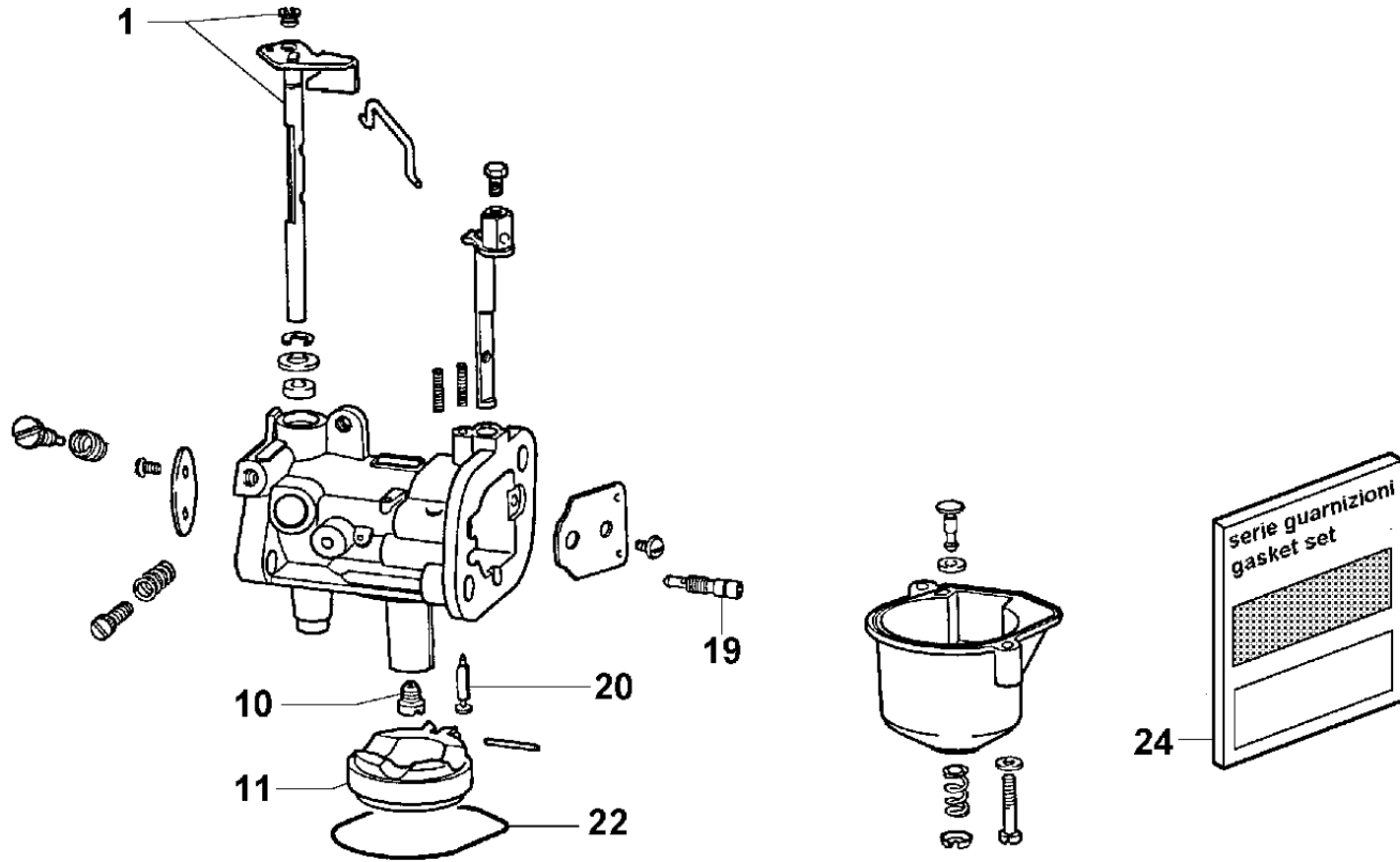

**CARBURETOR SPARE PARTS**

POS.	CODE	DESCRIPTION	Qty
01	«-----»	butterfly shaft	0
02	non cod.	retainer	0
10	4126.092	main jet 0,84	1
11	4105.022	float	1
12	non cod.	push botton rod	0
19	4126.091	idle jet (0,42)	1
20	9850.134	needle valve cushioned type	1
21	non cod.	float pin	0
22	«-----»	bowl gasket - see Pos. F 24	0
23	non cod.	screw	0
24	8180.198	carburetor gasket set	1



**G**  
**LGA**  
**280**  
**340**

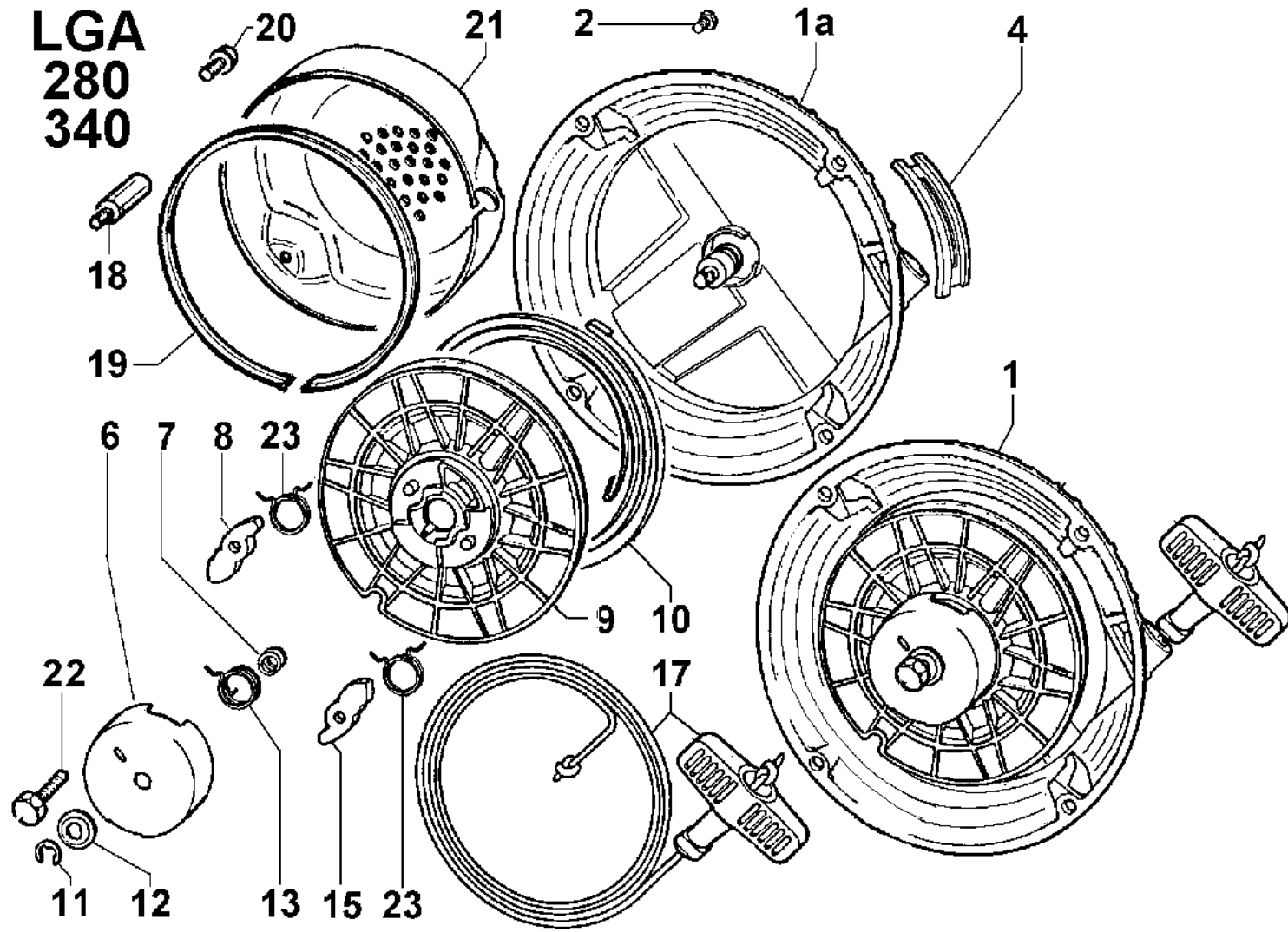



Group: LGA 280-340  
 Engine: LGA 280 Drawing: G

**REWIND STARTER**

POS.	CODE	DESCRIPTION	Qty
01	1472.057	REWIND STARTING	1
01a	«-----»	see Pos. G 01	0
02	1760.130	bolt M 6 x 1 x 12	4
04	«-----»	see Pos. G 01	0
06	7980.063	cup	1
07	5590.026	thrust spring	1
08	5025.097	tooth	1
09	7100.377	recoil pulley	1
10	5801.539	spiral spring	1
11	«-----»	see remarks	0
13	5660.066	recovery spring	1
15	5025.097	tooth	1
17	4904.038	handle ass.y	1
18	3527.470	hollowstud for electr.starting	4
18	3527.471	hollowstud	4
19	«-----»	gasket	0
20	1760.130	bolt M 6 x 1 x 12	4
21	«-----»	guard housing	0
21	6927.358	grass guard	1
22	9730.340	screw M 5 x 10	1
23	«-----»	tooth recovery spring	0

Additional Info - Engine: LGA 280 Drawing: G

REWIND STARTER

Pos.	Old part	Serv.Lett.	Notes	S.No/Date
G 01	1471.089	22020	Pos. G01-G04-G06-G07-G08-G09-G10-G11-G12-G13-G15-G16-G17-G22-G23 -	.....
G 08	5025.094	25007	-	.....
G 09	7100.371	25007	- old type no longer avial. - superseded by new complete rewind starter	.....
G 11	1165.006	25007	- fitted until shown engine s.no	.....
G 15	5025.094	25007	-	.....
G 22		25007	- starting from shown engine s.no	.....
G 23	5660.078	25007	- in fact never fitted	02.2002

# H

LGA  
280  
340

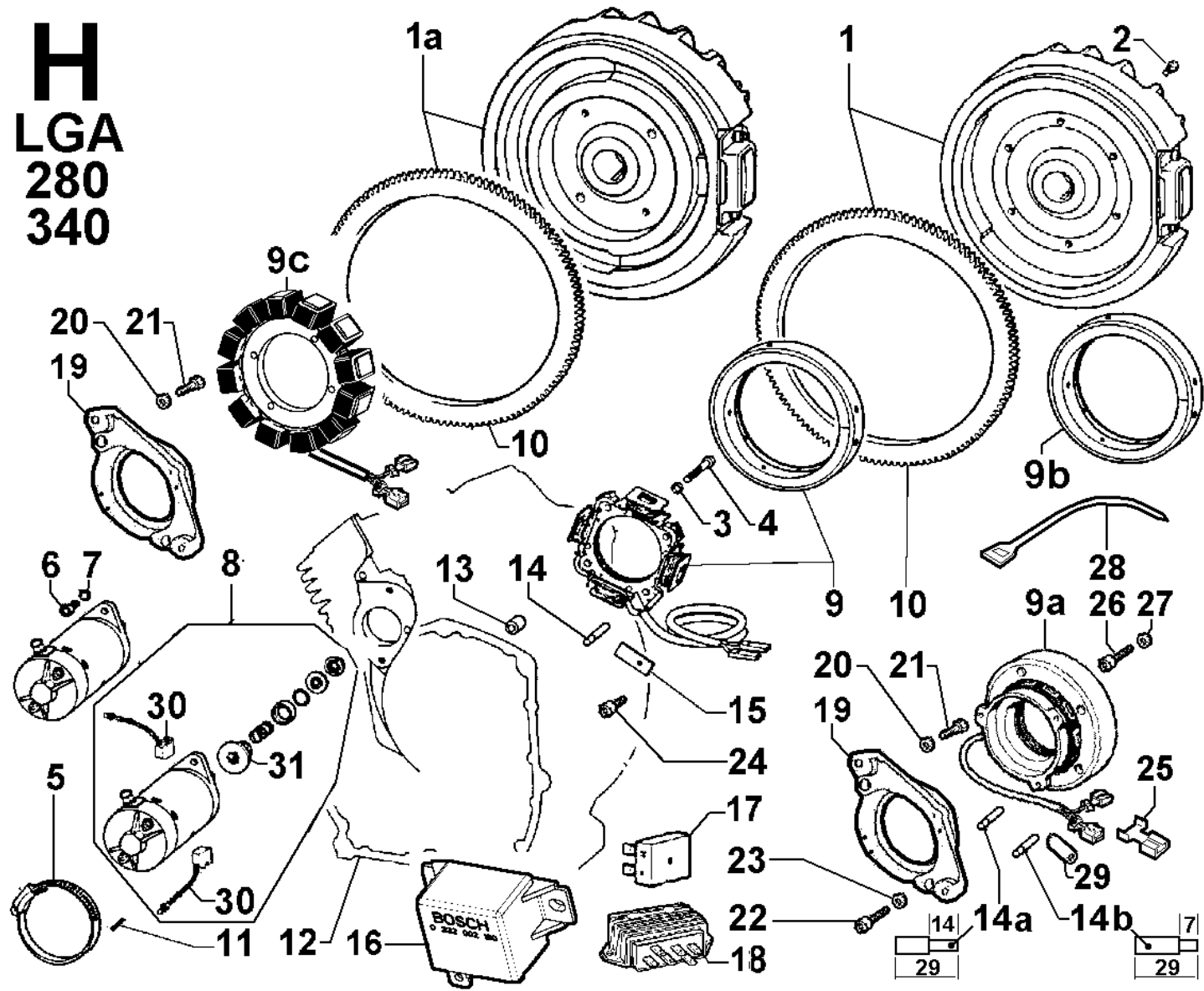





**Group: LGA 280-340**  
**Engine: LGA 280 Drawing: H**

**ELECTRICAL STARTING (optional)**

POS.	CODE	DESCRIPTION	Qty
01	9881.272	flywheel for alternator 3 wires	1
01	9881.520	flywheel ass.y for alternator 2 wires (for el.starting and/or	1
01a	9881.519	flywheel with crown gear	1
02	9732.084	screw M 6 X 12	6
03	7645.005	washer diam. 6	2
04	9732.018	screw M 6 X 45	2
05	3617.203	clamp diam. 40 - 60	1
06	9730.012	screw M 6 X 20	2
07	7645.005	washer diam. 6	2
08	5840.188	starting motor	1
09	1157.322	alternator 12V 70W - 2wires	1
09a	014A.212	volt.alternator 12V 180W - 3 wires	1
09b	220A.119	MAGNET	1
09c	1157.366	volt.alternator stator 2 wires	1
10	2816.106	crown gear	1
11	8430.107	lockpin diam. 3X28 UNI 6873	1
12	1510.778	CRANKCASE std and for el.starting	1
13	8400.138	spacer	2
14	8430.111	lockpin for 70W alternator	2
14a	8430.120	lockpin for 12V 14A alternator - 3 wires	1
14b	8430.121	lockpin for 12V 14A alternator - 3 wires	1
15	6370.334	safety plate	1
15	6370.599	safety plate	1
16	5041.019	relay	1
17	6607.016	rectifier bridge	1
18	7362.228	voltage regulator. 12V 14/21A-6 contacts for alternator 3 wires	1
19	8725.075	alternator support 180W	1
20	7645.005	washer diam. 6	2
21	9730.010	screw M 6 X 16	2
22	9730.368	screw M 5 X 18	4
23	7645.001	washer diam. 5	4
26	9730.015	screw M 6 X 30	5
27	7645.005	washer diam. 6	5
28	2471.039	clamp mm 90	2
29	930A.193	wire sleeve	1
30	8310.043	brush set	1
31	6456.046	pinion for starting motor	1



**LGA  
280  
340**

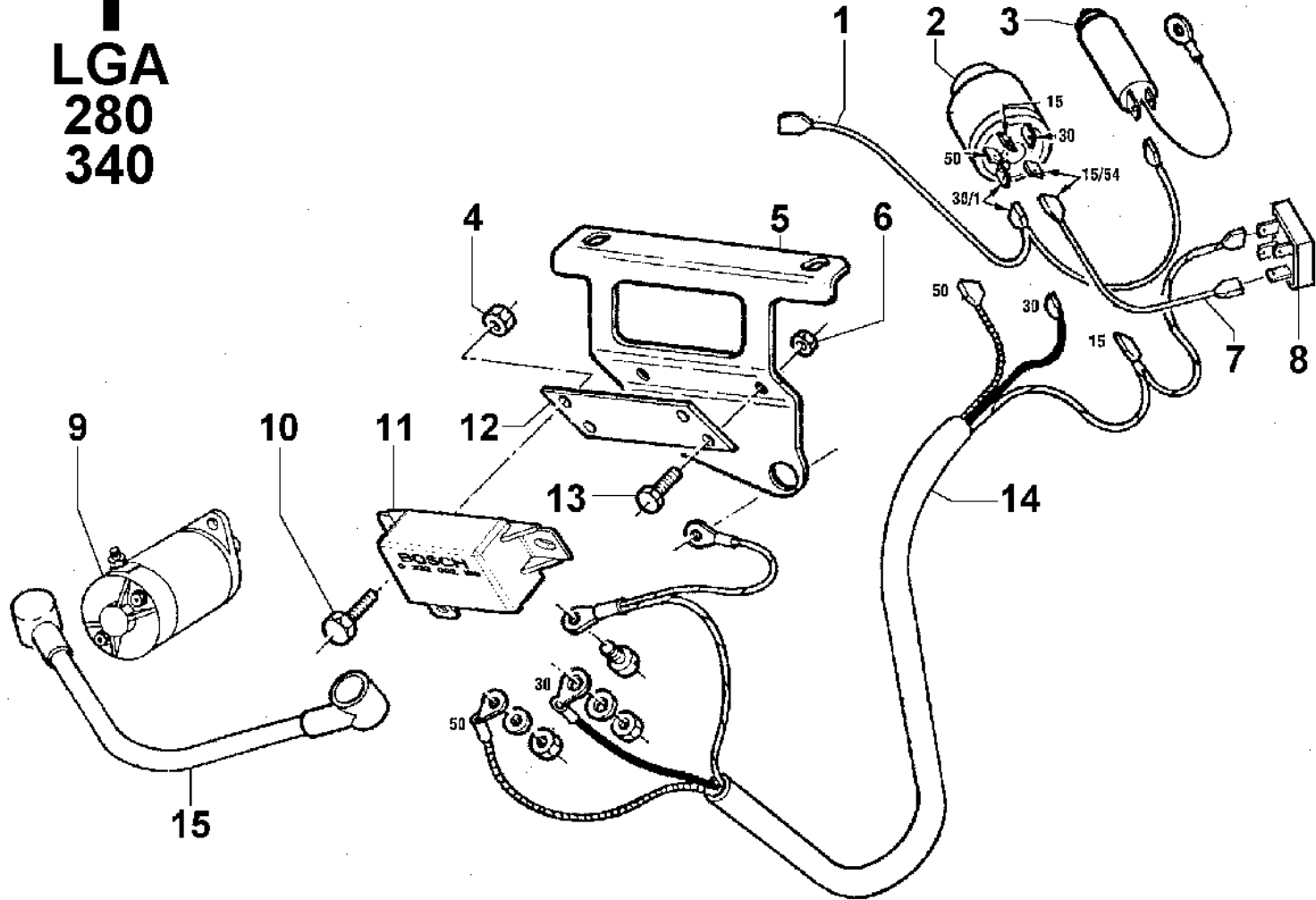

**ELECTRICAL STARTING (optional)**

POS.	CODE	DESCRIPTION	Qty
01	2185.920	wire	1
02	5041.257	key switch	1
03	8345.069	warning device	1
04	3203.050	selflocking nut M 6	1
04	3300.190	drilling plate	1
05	8865.195	support	1
06	3203.050	selflocking nut M 6	1
06	3300.190	drilling plate	1
07	2185.935	wire	1
08	6607.016	rectifier bridge	1
09	5840.188	starting motor	1
10	1760.005	bolt M 6 X 1 X 16	2
10	9760.018	self-tapping screw 4,2 X 16	2
11	5041.019	relay	1
12	6330.090	plate	1
13	1760.005	bolt M 6 X 1 X 16	2
13	9760.018	self-tapping screw 4,2 X 16	2
14	2185.932	electrical wire	1
15	2185.931	electrical wire	1



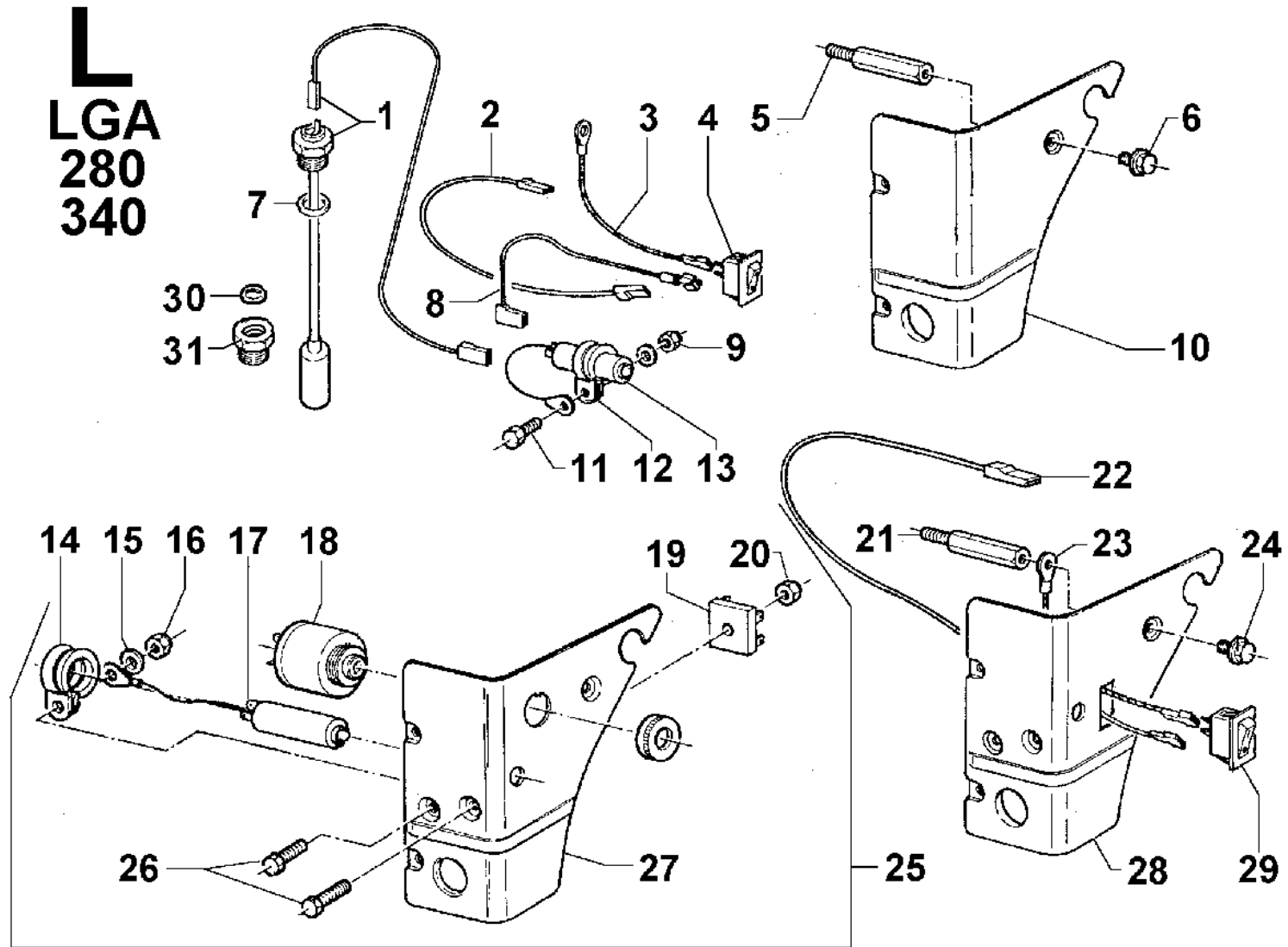

**ELECTRICAL STARTING (optional)**

POS.	CODE	DESCRIPTION	Qty
01	4906.056	elect.gauge M 22	1
02	2185.920	wire	1
03	2185.934	wire	1
04	5041.260	earth push button	1
05	3527.432	hollowstud	1
06	1760.130	bolt M 6 X 1 X 12	1
07	1200.293	ring	1
08	2185.935	wire	1
09	3203.038	nut M 5x0,8	1
10	5981.088	panel (for engine with rewind starter)	1
11	1755.020	screw	2
12	8903.101	warning light support	1
13	8345.069	warning device	1
14	8903.101	warning light support	1
15	771R.001	washer diam. 5,3	1
16	3260.130	nut	1
17	8345.069	warning device	1
18	5041.257	key switch	1
19	6607.016	rectifier bridge	1
20	3260.130	nut	1
21	3527.432	hollowstud	1
22	2185.920	wire	1
23	2185.934	wire	1
24	1760.130	bolt M 6 X 1 X 12	1
25	«-----»	electrical panel	0
26	1755.020	screw	2
27	5981.089	panel for key switch	1
28	5981.087	panel for key switch	1
29	5041.260	earth push button	1
30	1200.288	seal ring	1
31	4130.125	reduction locking nut	1

**Additional Info - Engine: LGA 280 Drawing: L**

**ELECTRICAL STARTING (optional)**

Pos.	Old part	Serv.Lett.	Notes	S.No/Date
L 01	4906.049	25009	-	7505896
	4906.052	25010	- old type is M 15	7506395
L 07	1200.293	25009	-	7505896
	1200.295	25010	-	7506395
L 10	5981.085	25006	-	7504983
L 25	7245.386	25.09.2007	-	
L 27	5981.084	25006	-	7504983
L 28		25001	- starting from shown engine s.no	7500673
	5981.083	25006	-	7504983
L 30		25009	- to use new oil dipstick M15 on old crankcases	7505896
L 31		25009	- to use new oil dipstick M15 on old crankcases	7505896



**Z**  
**LGA**  
**280**  
**340**



Group: LGA 280-340  
Engine: LGA 280 Drawing: Z

**SHORT BLOCK**

POS.	CODE	DESCRIPTION	Qty
1	«-----»	short block conical PTO	0

**SHORT BLOCK**

Pos.	Old part	Serv.Lett.	Notes	S.No/Date