



our **power**, your **passion**

NIBBI MAK 4

(EN 709 - ÅRG. 2012 OG FREM)



Henrik A. Fog A/S

Lyngager 5-11

2605 Brøndby

Tel 43966611

Fax 43266624

reservedele@hafog.dk

www.hafog.dk

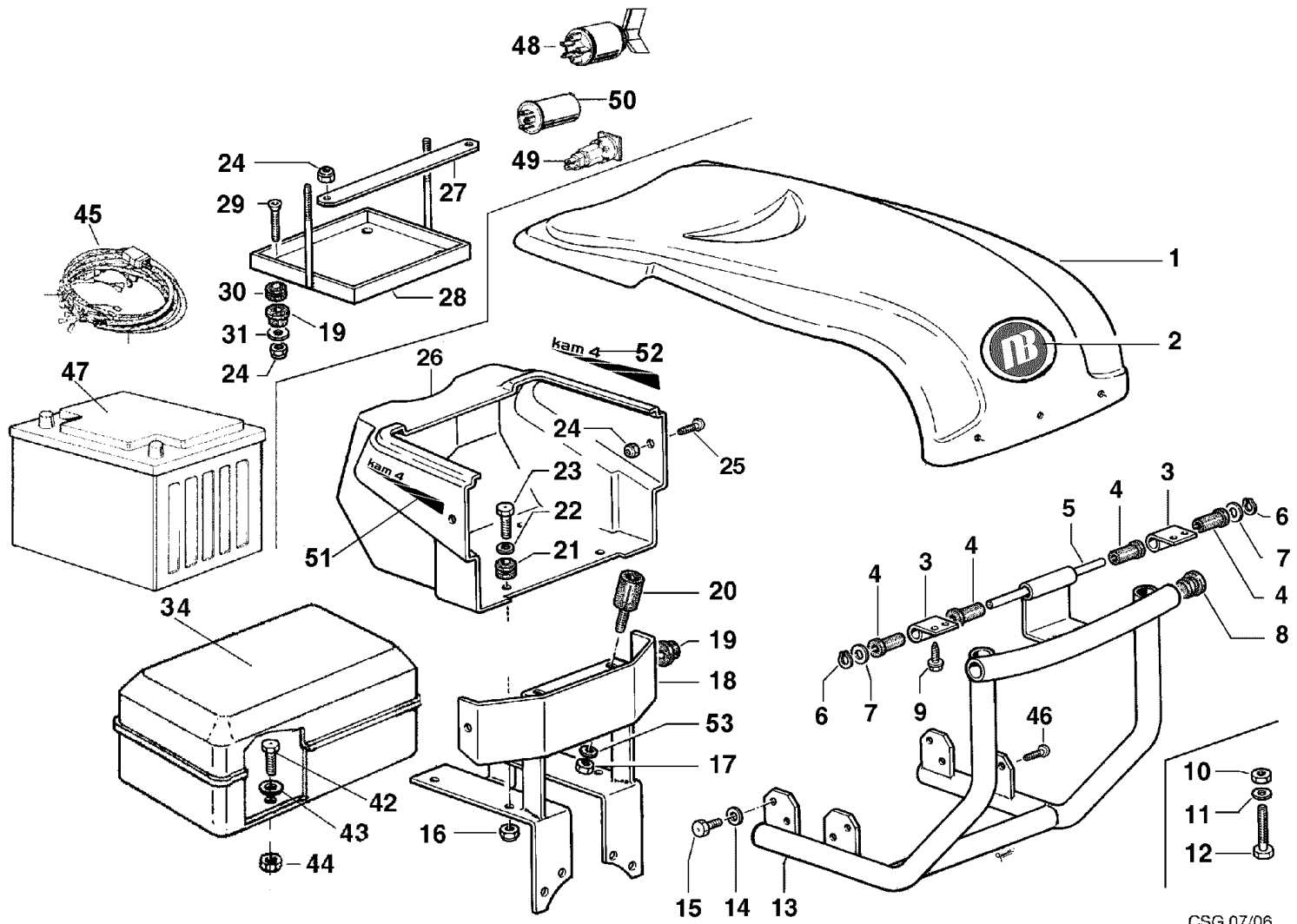

CSG 07/06

Ref.Nu	Qty	Part number	Description	Validity from	Validity till	Notes	Bulletin
1	1	68320022R	Hood			Honda GX270; Honda GX200; CH395; 15LD315; 15LD350; Rosso; Red	
2	1	68320084R	Mark			Su richiesta; Upon request	
3	1	F1292105	Support				
4	1	YN0400700	Bushing				
5	1	F1292106	Pin				
6	1	YN0102900	Ring				
7	1	3916010R	Washer				
8	1	N5267400	Cap				
9	1	N6243654	Screw				
10	1	3914010R	Nut			Honda GX160	
10	1	006000091R	Nut			15LD400; 15LD400 AE; 15LD315; 15LD350; 15LD350 AE; Honda GX270; Kohler CH395; Kohler CH395 AE	
11	1	YN4376400	Washer			15LD400; 15LD400 AE; 15LD315; 15LD350; 15LD350 AE; Honda GX270; Kohler CH395; Kohler CH395 AE	
11	1	3916008R	Washer			Honda GX160	
12	1	YN6335900	Screw			15LD315; 15LD350; 15LD350 AE; 15LD400; 15LD400 AE	
12	1	3806067R	Screw			Honda GX160	
12	1	N6354300	Screw			Honda GX270	
13	1	68320063	Support			15LD400; 15LD400 AE; Grigio; Grey	
13	1	68320058	Support			Honda GX160; Grigio; Grey	
13	1	68320057	Support			Honda GX270; Grigio; Grey	
13	1	68320066	Support			Honda GX340; Grigio; Grey	
13	1	68320068	Support			Kohler CH395; Grigio; Grey	
13	1	68320064	Support			15LD315; 15LD350; Grigio; Grey	
14	-	-	Not available for this product				
15	-	-	Not available for this product				
16	1	3914010R	Nut			15LD400; 15LD400 AE; 15LD315; 15LD350; 15LD350 AE; Honda GX270; Kohler CH395; Kohler CH395 AE	
17	1	320000028R	Nut				
18	1	68320044	Support			Honda GX160; Grigio; Grey	
18	1	68320007R	Support			15LD400; 15LD400 AE; Honda GX340; Kohler CH395; Kohler CH395 AE; Grigio; Grey	
18	1	68320043	Support			Honda GX270; 15LD315; 15LD350; 15LD350 AE; Grigio; Grey	
19	1	F0752170	Buffer				
20	1	YF0752159	Silent block				
21	1	YN0400530	Grommet			15LD400; 15LD400 AE; 15LD315; 15LD350; 15LD350 AE; Honda GX270; Kohler CH395; Kohler CH395 AE	
22	1	3916008R	Washer			15LD400; 15LD400 AE; 15LD315; 15LD350; 15LD350 AE; Honda GX270; Kohler CH395; Kohler CH395 AE	
23	1	3806067R	Screw			15LD400; 15LD400 AE; 15LD315; 15LD350; 15LD350 AE; Honda GX270; Kohler CH395; Kohler CH395 AE	
24	1	3914006R	Nut			15LD400; 15LD400 AE; 15LD315; 15LD350; 15LD350 AE; Honda GX270; Kohler CH395; Kohler CH395 AE	
25	1	N6218600	Screw			15LD400; 15LD400 AE; 15LD315; 15LD350; 15LD350 AE; Honda GX270; Kohler CH395; Kohler CH395 AE	
26	1	68320024	Hood			15LD400; 15LD400 AE; 15LD315; 15LD350; 15LD350 AE; Honda GX270; Kohler CH395; Kohler CH395 AE; Rosso; Red	
26	1	68320026	Hood			Avviamento elettrico; Electric starter	
27	1	F1292601	Main board			Avviamento elettrico; Electric starter; 15LD400; 15LD400 AE; 15LD315; 15LD350; 15LD350 AE; Kohler CH395; Kohler CH395 AE	
28	1	68320056C	Battery casing			Avviamento elettrico; Electric starter; 15LD400; 15LD400 AE; 15LD315; 15LD350; 15LD350 AE; Kohler CH395; Kohler CH395 AE; Grigio; Grey	
29	1	N6233000	Screw			Avviamento elettrico; Electric starter;	

Ref.Nu	Qty	Part number	Description	Validity from	Validity till	Notes	Bulletin
						15LD400; 15LD400 AE; 15LD315; 15LD350; 15LD350 AE; Kohler CH395; Kohler CH395 AE	
30	1	YN0400530	Grommet			Avviamento elettrico; Electric starter; 15LD400; 15LD400 AE; 15LD315; 15LD350; 15LD350 AE; Kohler CH395; Kohler CH395 AE	
31	1	YN4361900	Washer			Avviamento elettrico; Electric starter; 15LD400; 15LD400 AE; 15LD315; 15LD350; 15LD350 AE; Kohler CH395; Kohler CH395 AE	
34	1	F1221601	Box			Honda GX160	
42	1	3806035R	Screw			Honda GX160; Kohler CH395; Kohler CH395 AE	
43	1	3916006R	Washer			Honda GX160; Kohler CH395; Kohler CH395 AE	
44	1	3914006R	Nut			Honda GX160; Kohler CH395; Kohler CH395 AE	
45	1	68330139	Electric starter			15LD315; 15LD350; 15LD400	
45	1	68330139	Electric starter			Kohler CH395; Kohler CH395 AE	
46		-	Not available for this product				
47	1	68330115R	Battery				
48	1	N2540020	Switch				
49	1	N2552250	Warning light				
50	1	N2552370	Plug				
51	1	68320077	Mark			Su richiesta; Upon request; DX; RIGHT	
52	1	68320078	Mark			Su richiesta; Upon request; SX; LEFT	
53	1	YN4365400	Washer				

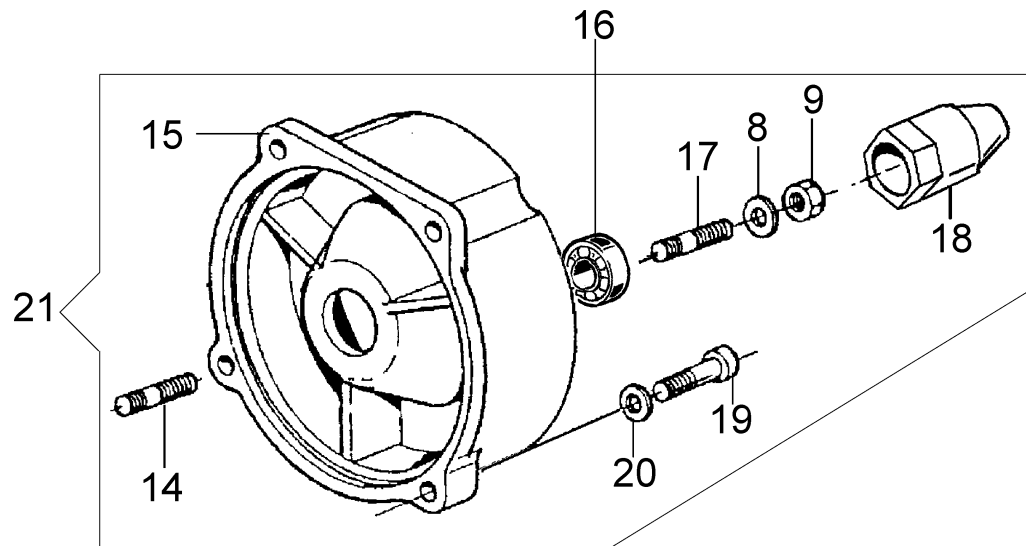
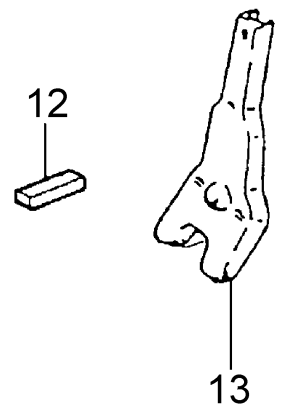
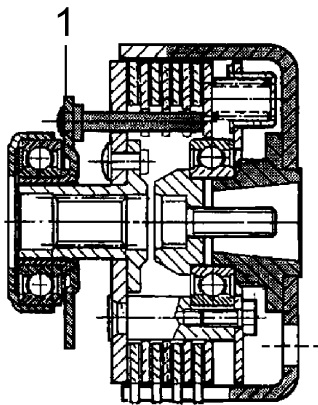
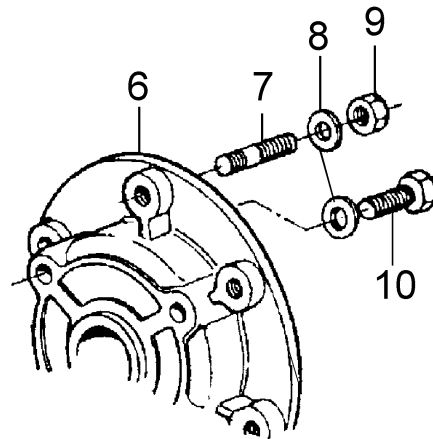
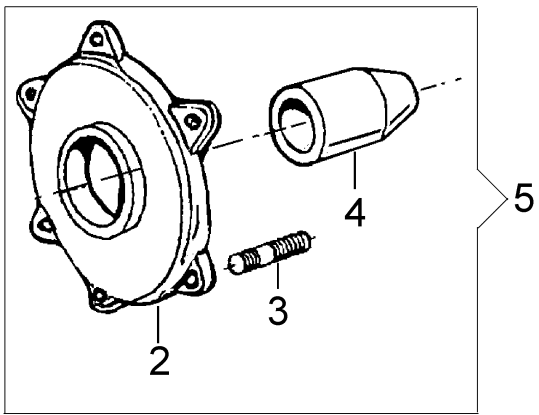

Ref.Nu	Qty	Part number	Description	Validity from	Validity till	Notes	Bulletin
1	1	68320122	Clutch			Inversa, Reverse; Honda GX 270; Kohler CH395	
1	1	68320123	Clutch			Inversa, Reverse; Honda GX200;	
1	1	68320119	Clutch			Inversa, Reverse; Lombardini 15LD350;	
2	1	F1210001	Spacer			Per motori Lombardini 15LD350; For Lombardini 15LD350 engine	
3	6	K8236004	Stud			Per motori Lombardini 15LD350; For Lombardini 15LD350 engine	
4	1	F1210002	Spacer			Per motori Lombardini 15LD350; For Lombardini 15LD350 engine	
5	1	P1200020	Spacer unit			Per motori Lombardini 15LD350; For Lombardini 15LD350 engine	
6	1	68310038A	Flange			Per motori Honda GX; For Honda GX engine	
7	6	YN3812500	Stud				
8	11	YN4365400	Washer				
9	7	320000028R	Nut				
10	1	YN6243980	Screw			Per motori Honda GX200; For Honda GX200 engine	
11	1	68320146	Spacer			Per motori Honda GX200; For Honda GX200 engine	
12	1	N0648090	Key			Per motori Honda GX270; For Honda GX270 engine	
13	1	YF0750011	Lever				
14	4	N3815300	Stud				
15	1	68320117A	Flange			Per motori Honda GX270 e Kohler CH395; For Honda GX270 and Kohler CH395 engines	
16	1	N1289300	Bearing				
17	1	N3815300	Stud				
18	-	-	Not available for this product				
19	4	N6309790	Screw				
20	4	YN4376400	Washer				
21	-	-	Not available for this product				

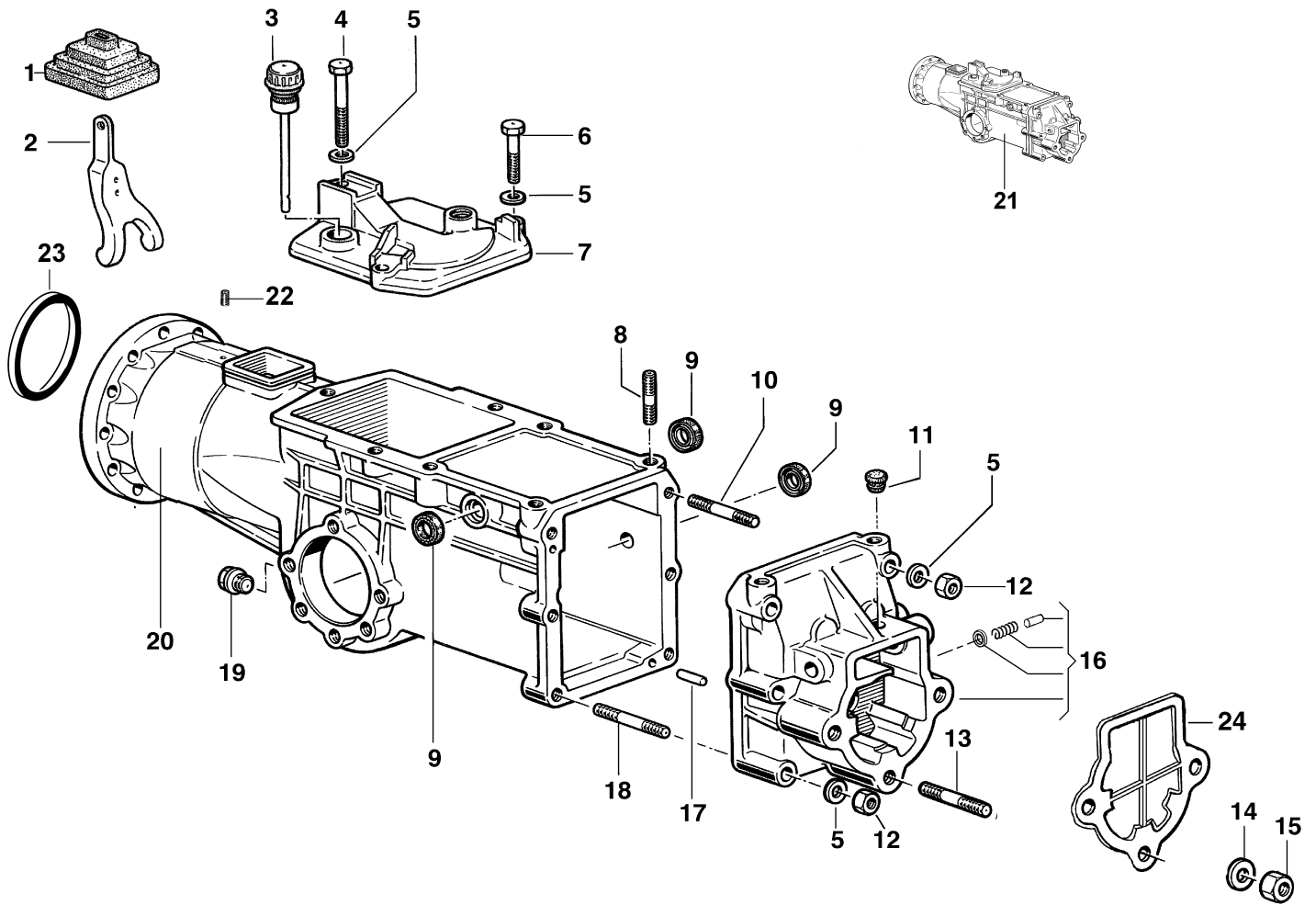

Ref.Nu	Qty	Part number	Description	Validity from	Validity till	Notes	Bulletin
1	1	YF0751646	Bellows				
2	1	YF0750011	Lever				
3	1	F1290819	Cap				
4	1	N6294400	Screw				
5	1	YN4365400	Washer				
6	1	3806074R	Screw				
7	1	F1290802	Upper cover				
8	1	YN3812500	Stud				
9	1	YN0203000	Seal ring				
10	1	N3825400	Stud				
11	1	YF0750835	Cap				
12	1	N1458800	Nut				
13	1	N3861500	Stud				
14	1	YN4387700	Washer				
15	1	YN1470500	Nut				
16	1	YF1290817	Set cover				
17	1	YN5124300	Pin				
18	1	N3825750	Stud				
19	1	YN5254000	Oil cap				
20	1	68320135	Speed-change gear box				
21	1	68322133R	Unit (Gear)	SN B053499349			
21	1	68322057	Unit (Gear)		SN B053499348		
22	1	N6203600	Screw				
23	1	68320137A	Ring				
24	1	F1050833	Cover				

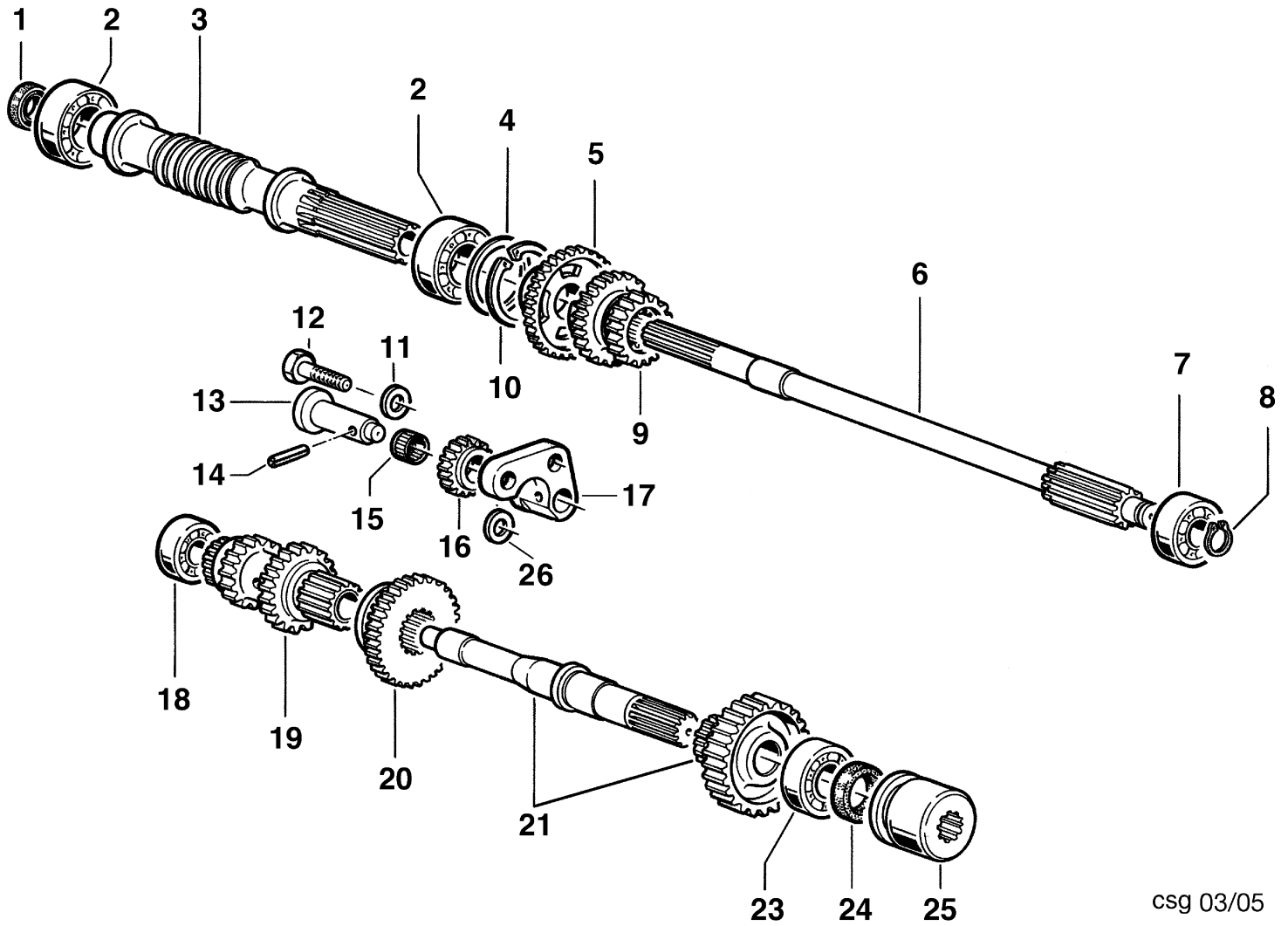

csg 03/05

Ref.Nu	Qty	Part number	Description	Validity from	Validity till	Notes	Bulletin
1	1	YN0204750	Gasket				
2	1	N1270751	Bearing				
3	1	F1290800	Shaft				
4	1	N5010200	Washer				
5	1	YF1290812	Sprocket				
6	1	YF1290811	Shaft				
7	1	N1257700	Bearing				
8	1	3024015	Seeger				
9	1	YF1290813	Gear (Sliding)				
10	1	N0136900	Seeger				
11	1	005000343	Washer				
12	1	N6327500	Screw				
13	1	F1290803	Pin				
14	1	N5115000	Cotter pin				
15	1	3037026R	Roller cage				
16	1	YF1290804	Sprocket				
17	1	F1290807	Support				
18	1	N1251500	Bearing				
19	1	F1290810	Gear				
20	1	YF1290805	Sprocket				
21	1	R1290814	Shaft (Complete)				
23	1	YN1263701	Bearing				
24	1	YN0207300	Seal ring				
25	1	YF1290816	Sleeve				
26	1	N5001900	Washer				

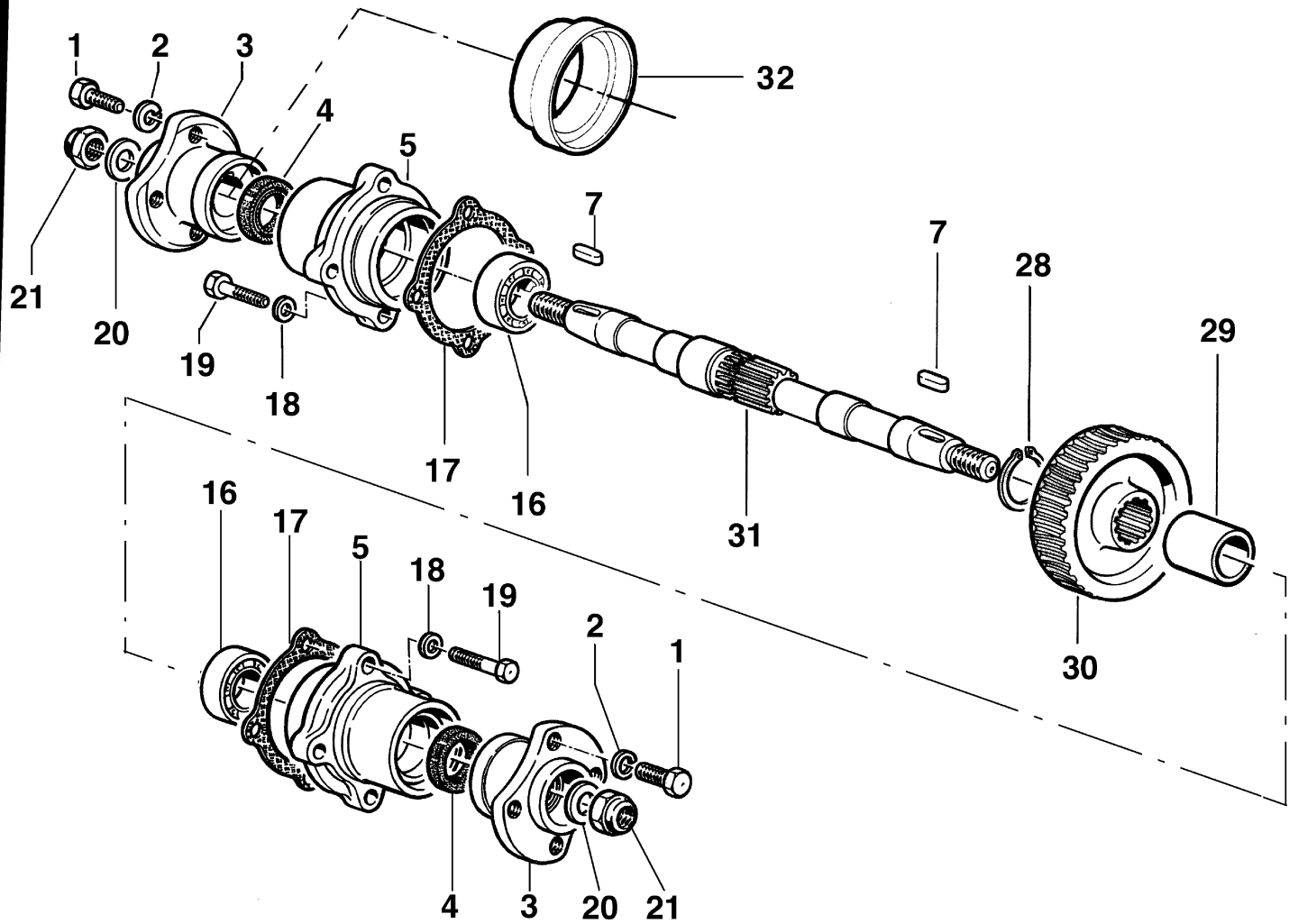

CSG 07/06

Ref.Nu	Qty	Part number	Description	Validity from	Validity till	Notes	Bulletin
1	1	N6322000	Screw				
2	1	3819014R	Grower				
3	1	YF1290211	Wheel hub				
4	1	YN0209720	Ring				
5	1	F1290209	Support				
7	1	YN0646800	Key				
16	1	N1272501	Bearing				
17	1	-	Not available for this product				
18	1	YN4365400	Washer				
19	1	3806067R	Screw				
20	1	N4403000	Grower				
21	1	YN1479800	Nut				
28	1	N0124150	Seeger				
29	1	F1290216	Spacer				
30	1	F1290215	Wheel				
31	1	YF1290214	Shaft				
32	1	F1290227	Guard				

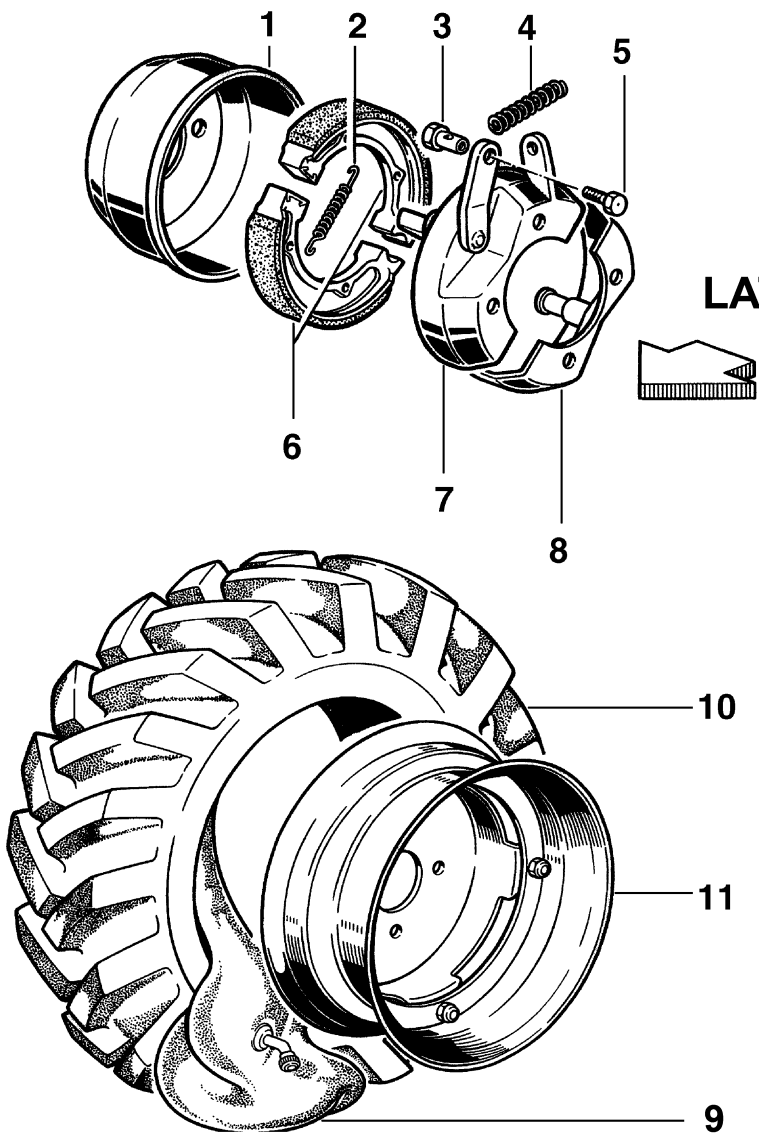

Ref.Nu	Qty	Part number	Description	Validity from	Validity till	Notes	Bulletin
1	1	N2382700	Cable reel				
2	1	YN3105100	Spring				
3	1	YF1290225	Clamp				
4	1	N3101050	Spring				
5	1	301000042	Screw				
6	1	YN2362700	Brake shoe				
7	1	F1290223	Half-cable reel				
8	1	YF1290220	Half-cable reel				
9	1	N4881500	Inner tube			4.00-10	
9	1	YN4882500	Inner tube			5.00-10	
10	1	N4852000A	Tire			4.00-10	
10	1	N4853500	Tire			5.00-10	
11	1	69200014	Rim			4.00/5.00-10	

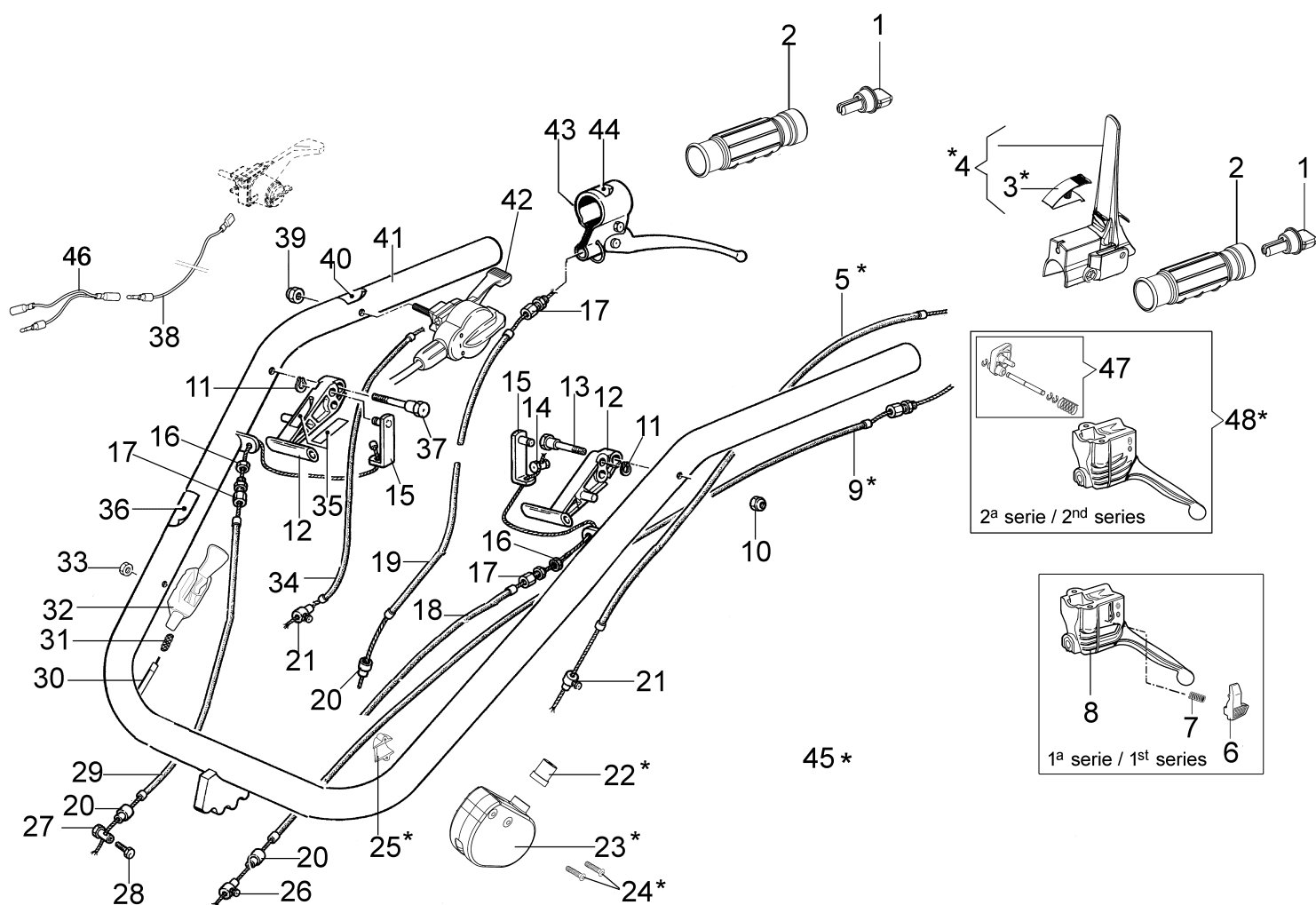

Ref.Nu	Qty	Part number	Description	Validity from	Validity till	Notes	Bulletin
1	2	68320127	Extension				
2	2	68320126R	Knob				
3	1	68240053	Hook + Pin				
4	1	68310061	Complete lever				
5	1	68320186	Rope				
6	1	68310073	Button		SN B053329009		BT12-006-02/14
7	1	68310074	Spring		SN B053329009		BT12-006-02/14
8	1	68310063	Lever		SN B053329009		BT12-006-02/14
9	1	68310064R	Rope				
10	1	3914010R	Nut				
11	2	N1734000	Ring				
12	2	F1291614	Lever				
13	1	F1291615	Pin				
14	1	N5901500	Clamp				
15	2	F1291619	Bracket				
16	2	3911008R	Nut				
17	3	YN5801000	Adjuster assy				
18	1	N5481100	Transmission				
19	1	68330195	Transmission				
20	3	YN5852100A	Clamp				
21	2	F1300004	Clamp				
22	1	68310066	Bushing				
23	1	68320187	Device Quick start				
24	2	68310068	Pin				
25	1	68310067	Clamp				
26	1	YN5901600	Clamp				
27	1	YF1290225	Clamp				
28	1	301000042	Screw				
29	1	68330191	Transmission				
30	1	68320138	Transmission			Per motori diesel; For Diesel engine	
31	1	68320134	Spring			Per motori diesel; For Diesel engine	
32	1	68320132	Lever (Stop)			Per motori diesel; For Diesel engine	
33	1	3914006R	Nut			Per motori diesel; For Diesel engine	
34	1	N5467270	Transmission			Honda GX160	
34	1	N5467260	Transmission			Honda GX270	
35	1	F1291648	Mark			Su richiesta; Upon request	
36	1	YN5380870	Mark (Instruction)			Su richiesta; Upon request	
37	1	F1291616	Pin				
38	1	68310059	Cable		SN B053469261	Per motori benzina; For gasoline engine	BT12-007-03/14, BT12-008-03/14
39	1	3914006R	Nut				
40	1	YN5380805	Mark (Accelerator)			Su richiesta; Upon request	
41	1	68320139B	Handle kit				
42	1	3044010R	Set (Cable Motor-stop - Fuel control - Button)	SN B053449246		Per motori benzina GX270 (ver.T1) - CH395; For gasoline engine GX270 (ver.T1) - CH395	BT12-008-03/14
42	1	3044018R	Set (Cable Motor-stop - Fuel control - Button)	SN B053469262		Per motori benzina GX270 (ver.T2); For gasoline engine GX270 (ver.T2)	BT12-007-03/14
42	1	YN2803660	Fuel control			Per motori benzina; For gasoline engine	
42	1	YN2803650	Fuel control			Per motori diesel; For Diesel engine	
43	1	N2806200	Handle				
44	1	YN5380665	Mark (Brake)			Su richiesta; Upon request	
45	1	68320136AR	Lever group	SN B053329010			BT12-006-02/14
46	1	68320169	Cable	SN B050505865	SN B053469261	Per motori Honda GX270; Honda GX340 versioni T2; For Honda GX270; Honda GX340 engine versions T2	BT12-005-06/12, BT12-007-03/14
47	1	68320198R	Button set	SN B053329010			BT12-006-02/14
48	1	68320199R	Complete lever	SN B053329010			BT12-006-02/14

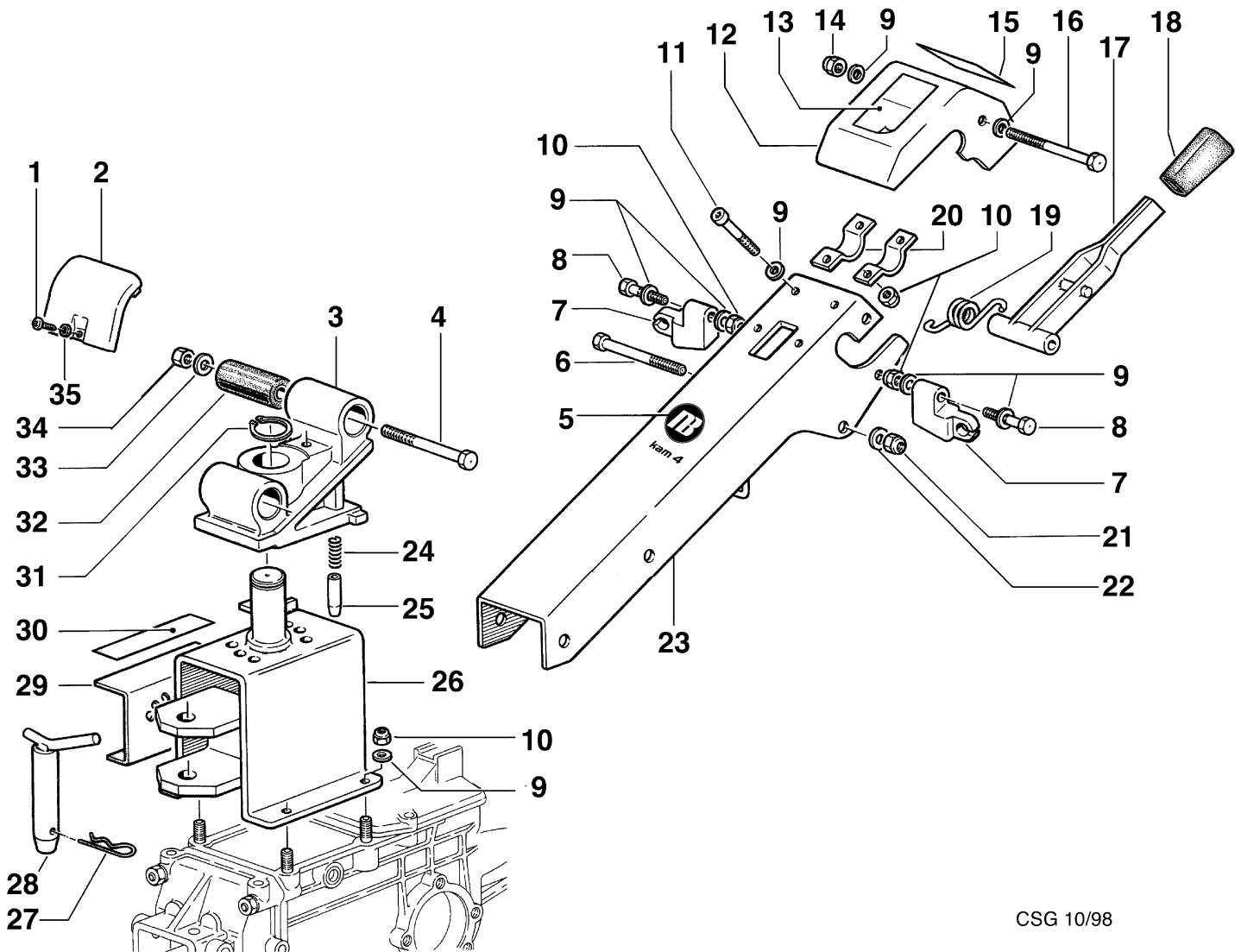

CSG 10/98

Ref.Nu	Qty	Part number	Description	Validity from	Validity till	Notes	Bulletin
1	1	N6192200	Screw				
2	1	68320040	Cover			Rosso; Red	
3	1	R0000114	Grip-end				
4	1	N6407550	Screw				
5	1	68320075	Mark			Su richiesta; Upon request	
6	1	YN6361500	Screw				
7	1	YF1255009B	Support				BT12-001-10/09
8	1	3806076	Screw				
9	1	3916008R	Washer				
10	1	N1458800	Nut				
11	1	N6289250	Screw				
12	1	68240022	Cover				
13	1	F1291647	Mark			Su richiesta; Upon request	
14	1	3914010R	Nut				
15	1	F1291650	Mark			Su richiesta; Upon request	
16	1	N6306500	Screw				
17	1	YF1291636	Lever				
18	1	YN2840480	Knob				
19	1	YF1291634B	Spring				
20	1	YF1151601	Clamp				
21	1	3914014R	Nut				
22	1	3916010R	Washer				
23	1	68320036D	Handlebar rod			Rosso; Red	
24	1	K3503380	Spring				
25	1	YK3502650	Shutter				
26	1	68320010ER	Column support			Grigio; Grey	
27	1	N5148800	Cotter pin				
28	1	F0751647	Pin				
29	1	68320106	Selector switch				
30	1	68910100R	Mark			Su richiesta; Upon request	
31	1	N0126400	Seeger				
32	1	N4924200	Silent block				
33	1	N4384360	Washer				
34	1	YN1470500	Nut				
35	1	3916005R	Sealing washer				

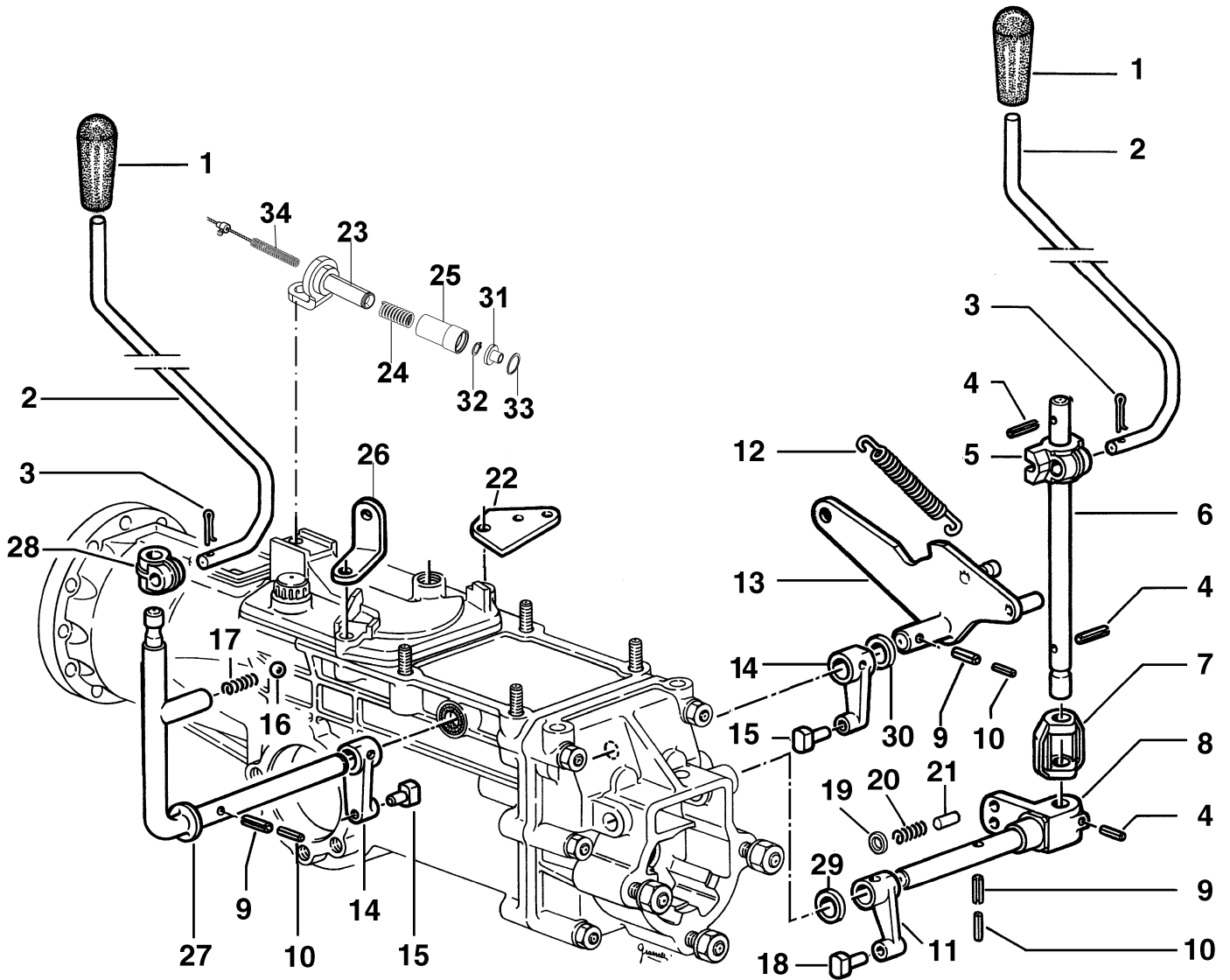

Ref.Nu	Qty	Part number	Description	Validity from	Validity till	Notes	Bulletin
1	1	YN3753600	Knob				
2	1	YF1291641	Handlebar				
3	1	YN1054900	Split pin				
4	1	N5113800	Pin				
5	1	YF1291633	Support				
6	1	YF1291637	Lever				
7	1	YF1241614	Shoe				
8	1	F1291613	Pin				
9	1	YN5125500	Pin				
10	1	YN5109300	Pin				
11	1	YF1051700	Lever				
12	1	YN3118060	Spring				
13	1	F1291612	Cam				
14	1	YF1291603	Lever				
15	1	YF1291604	Sliding block				
16	1	YN4745400	Ball				
17	1	YN3104250	Spring				
18	1	F1050831	Sliding block				
19	1	N0281400	Ring				
20	1	N3101020	Spring				
21	1	YF1291661	Cap				
22	1	F1291607	Plate				
23	1	68320113R	Pin				
24	1	N3119560	Spring				
25	1	68320116R	Bushing				
26	1	F1291605	Bracket				
27	1	YF1291632	Lever		SN B053499348		BT12-009-05/14
28	1	YF1061633	Fix plate (Handlebar)				
29	1	N4394700	Thickness				
30	1	K8491008	Thickness				
31	1	68310057	Washer				
32	1	3025027	Seeger				
33	1	3024012	Ring				
34	1	68320160R	Spring				

41*

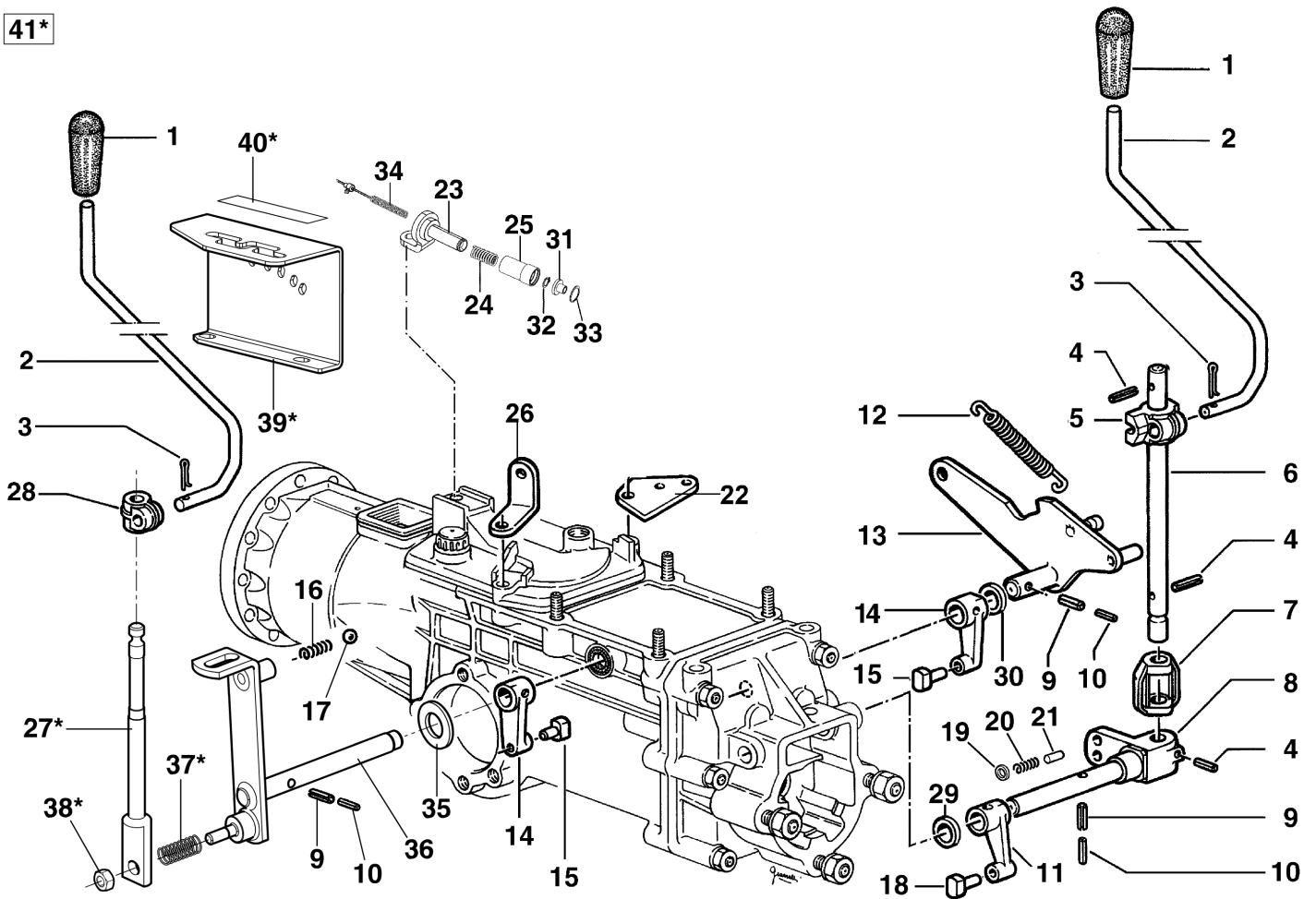

Ref.Nu	Qty	Part number	Description	Validity from	Validity till	Notes	Bulletin
1	1	YN3753600	Knob				
2	1	YF1291641	Handlebar				
3	1	YN1054900	Split pin				
4	1	N5113800	Pin				
5	1	YF1291633	Support				
6	1	YF1291637	Lever				
7	1	YF1241614	Shoe				
8	1	F1291613	Pin				
9	1	YN5125500	Pin				
10	1	YN5109300	Pin				
11	1	YF1051700	Lever				
12	1	YN3118060	Spring				
13	1	F1291612	Cam				
14	1	YF1291603	Lever				
15	1	YF1291604	Sliding block				
16	1	YN3104250	Spring				
17	1	YN4745400	Ball				
18	1	F1050831	Sliding block				
19	1	N0281400	Ring				
20	1	N3101020	Spring				
21	1	YF1291661	Cap				
22	1	F1291607	Plate				
23	1	68320113R	Pin				
24	1	N3119560	Spring				
25	1	68320116R	Bushing				
26	1	F1291605	Bracket				
27	1	68320152R	Lever (Selector switch)	SN B053499349			BT12-009-05/14
28	1	YF1061633	Fix plate (Handlebar)				
29	1	N4394700	Thickness				
30	1	K8491008	Thickness				
31	1	68310057	Washer				
32	1	3025027	Seeger				
33	1	3024012	Ring				
34	1	68320160R	Spring				
35	1	K8401029	Washer				
36	1	68320157R	Lever	SN B053499349			BT12-009-05/14
37	1	YN3111500	Spring	SN B053499349			BT12-009-05/14
38	1	3914010R	Nut	SN B053499349			BT12-009-05/14
39	1	68320172AR	Selector swicth	SN B053499349			BT12-009-05/14
40	1	68910100R	Mark				
41	1	68320209	Selector swicth/lever kit	SN B053499349			BT12-009-05/14

Movimento meccanico cod. 69229026

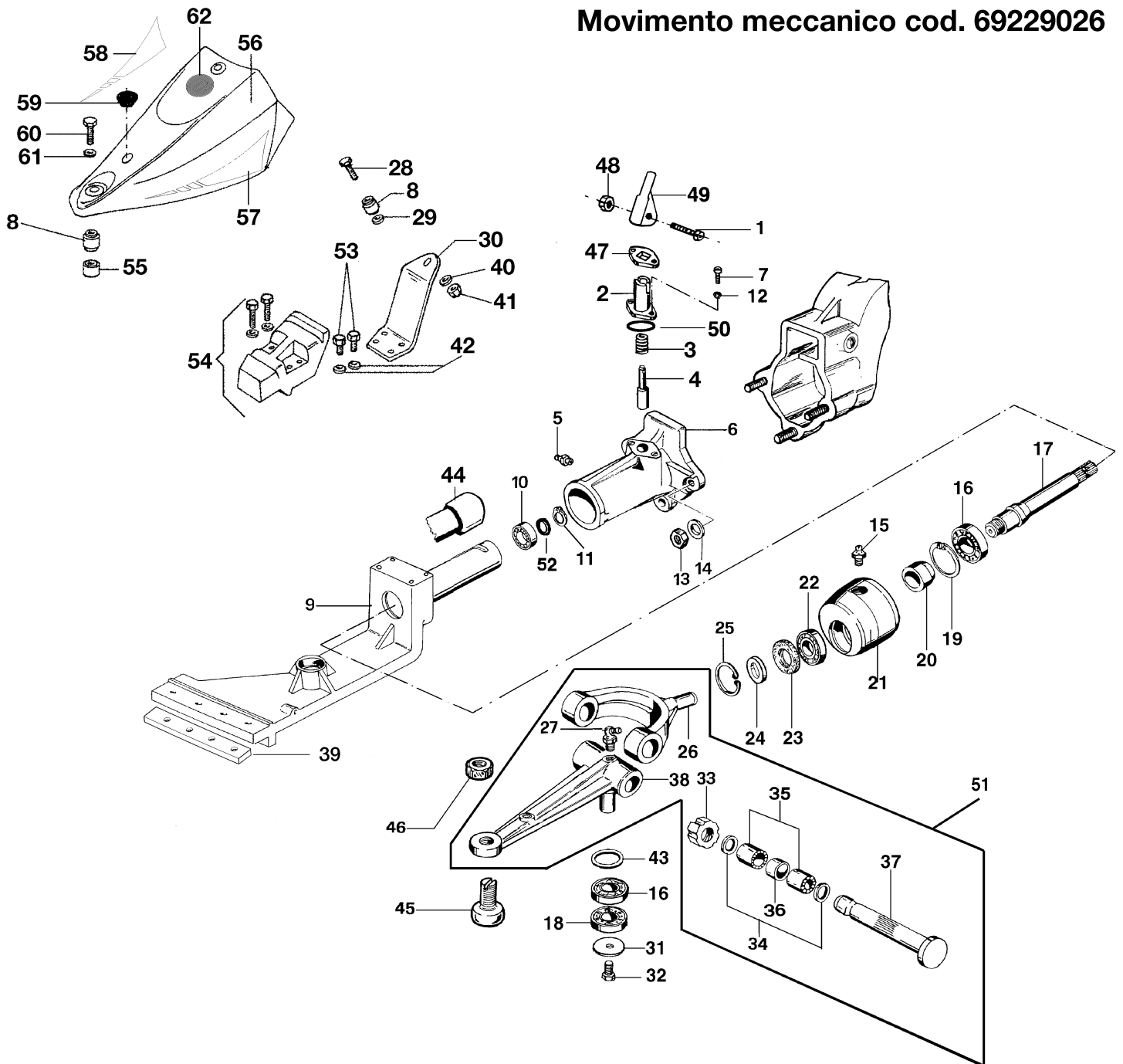

Ref.Nu	Qty	Part number	Description	Validity from	Validity till	Notes	Bulletin
1	1	3801027R	Screw				
2	1	YF1294702	Slide				
3	1	YN3118700	Spring				
4	1	YF1054710	Shutter				
5	1	YN2605600	Nipple				
6	1	L0100700	Quickfit			Corto; Short	
6	1	L0100300	Long QuickFit coupling			Lungo; Long	
7	1	3801022R	Screw				
8	1	N4924000	Silent block				
9	1	F1073358	Support				
10	1	YN1263201	Bearing				
11	1	3024020R	Seeger				
12	1	YN4358110	Washer				
13	1	YN1470500	Nut				
14	1	YN4387700	Washer				
15	1	YN2605600	Nipple				
16	1	YN1271100	Bearing				
17	1	YF1073106	Shaft				
18	1	N1270400	Bearing				
19	1	YN0136800	Seeger				
20	1	YF1073145	Spacer				
21	1	YF1073105	Floating head				
22	1	N1258301	Bearing				
23	1	YN0207500	Ring				
24	1	YN4429200	Washer				
25	1	YN0130000	Seeger				
26	1	F1073513	Clip				
27	1	YN2605600	Nipple				
28	1	N6399710	Screw				
29	1	3916012	Washer				
30	1	YF1303126	Support				
31	1	YF1073372	Washer				
32	1	N6320500	Screw				
33	1	N2101600	Ring nut				
34	1	N5002850	Spacer				
35	1	YN1261350	Bearing				
36	1	YF1073190	Spacer				
37	1	F1073191	Pin				
38	1	YF1073375	Connecting rod				
39	1	L0081100	Washer			Utilizzare con ruote > 4.00/5.00-10"; Use with wheels > 4.00/5.00-10	
40	1	3916012	Washer				
41	1	YN1470200	Nut				
42	1	3819013R	Grower				
43	1	YN5005400	Spacer				
44	1	L0038100	Spacer				
45	1	YF1073260	Pin				
46	1	N1474500	Nut				
47	1	YF1294701	Plate				
48	1	3914008R	Nut				
49	1	YF1294700	Lever				
50	1	3049016R	O-ring				
51	1	P0001289	Support kit				
52	1	YK7035045	O-ring				
53	1	3806031	Screw				
54	1	L0105500	Set (Counterweight) Mechanical movement				
55	1	F1303133	Spacer				
56	1	PA001254	Hood				
57	1	68910014	Mark			Su richiesta; Upon request	
58	1	68910015	Mark			Su richiesta; Upon request	
59	1	YN5265900	Cap				
60	1	N6399710	Screw				
61	1	3916012	Washer				
62	1	68250018	Label			Su richiesta; Upon request	

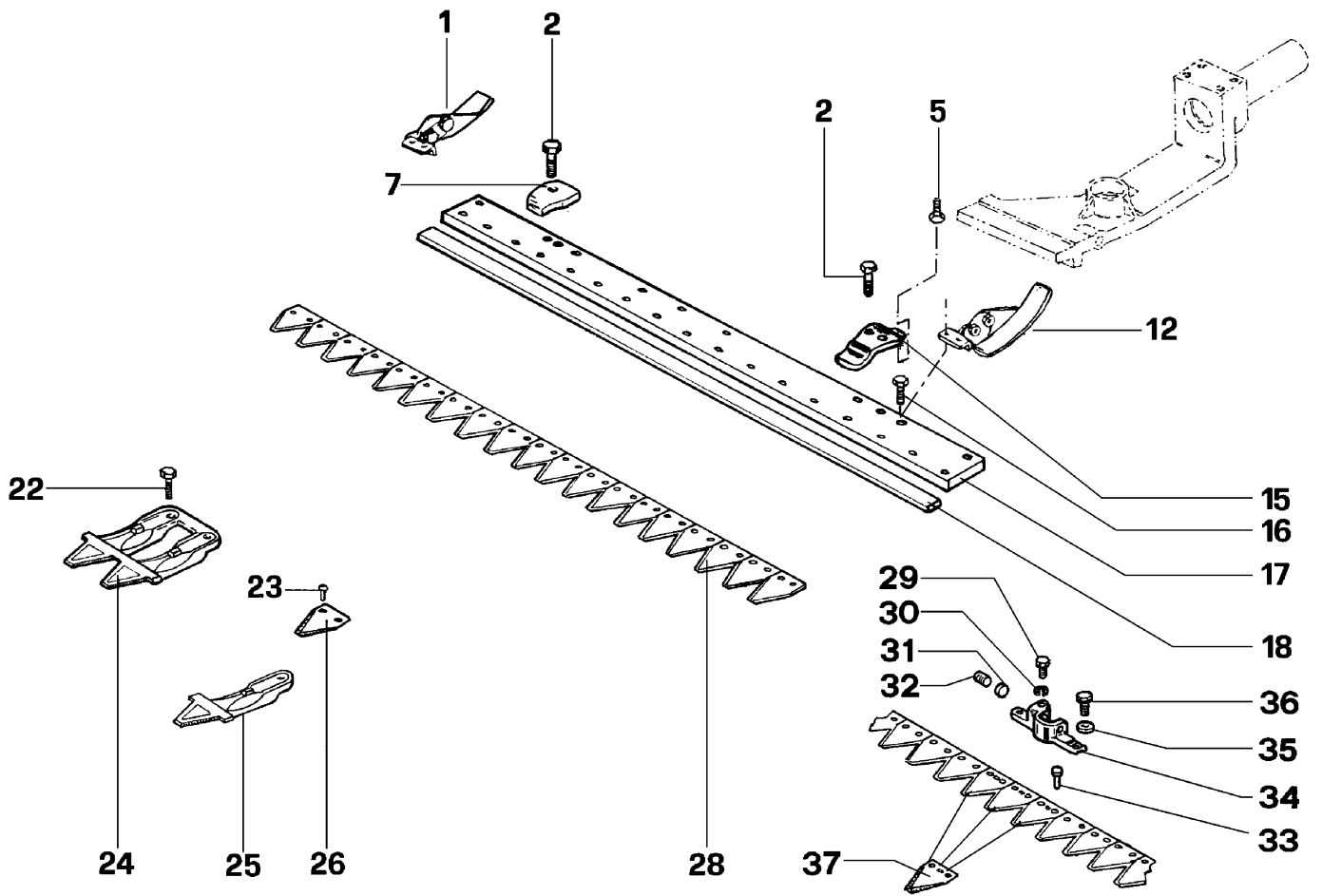

barra speciale attacco registrabile

Ref.Nu	Qty	Part number	Description	Validity from	Validity till	Notes	Bulletin
1	1	YF1303153	Sliding block				
2	1	YN6332800	Screw				
5	1	N6245800	Screw				
7	1	YF0582687	Plate				
12	1	YF1303153	Sliding block				
15	1	F1113112	Press blade (Long)				
16	1	N6321250	Screw				
17	1	F1303116	Plate			950 mm	
17	1	F1303117	Plate			1150 mm	
17	1	F1303118	Plate			1270 mm	
18	1	F0591593	Slide			1270 mm	
18	1	F0712027	Slide			950 mm	
18	1	69220017	Rod			1150 mm	
22	1	N6322000	Screw				
23	1	YN0886600	Rivet				
24	1	F1113114	Tooth (Double)				
25	1	F1113114	Tooth (Double)				
26	1	F1073216R	Blade				
28	1	YF1073276	Blade			1150 mm SP	
28	1	YF1073277	Blade			1270 mm SP	
28	1	YF1073349	Blade			950 mm SP	
29	1	YN6262200	Screw				
30	1	3819013R	Grower				
31	1	YF1073364	Valve				
32	1	N6433900	Screw				
33	1	F1073261	Rivet				
34	1	YF1073363B	Clutch driver			Per barra SP; For SP bar	
35	1	3819013R	Grower				
36	1	3806063	Screw				
37	1	YF1073273	Blade				

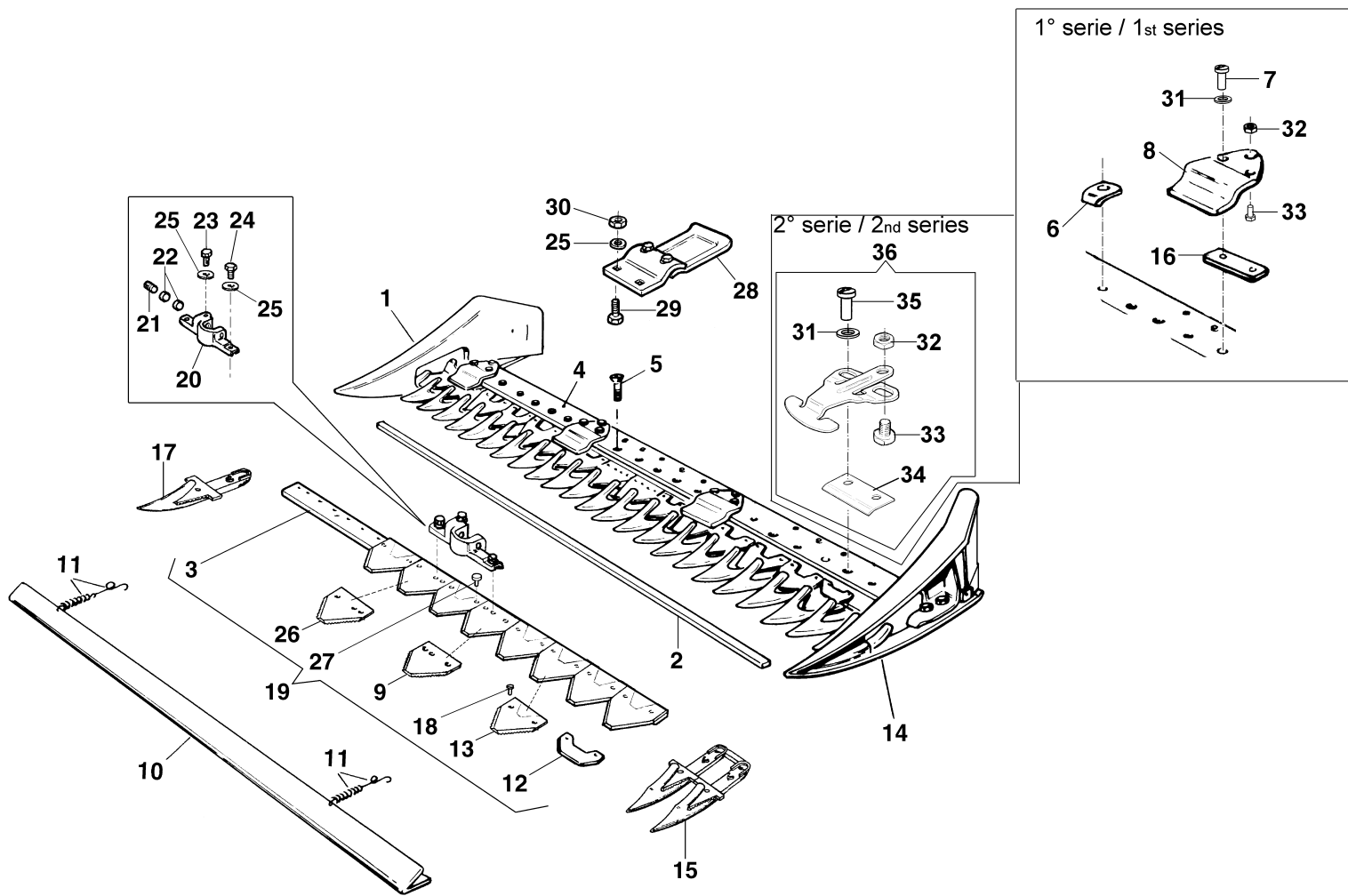

Ref.Nu	Qty	Part number	Description	Validity from	Validity till	Notes	Bulletin
1	1	69220015	Shoe			DX; RIGHT	
2	1	69220017	Rod				
3	1	69220023	Rod				
4	1	F1303117	Plate				
5	15	YN6325400	Screw				
6	4	69220018	Support		31/12/2013		BT12-010-07/14
7	8	3906099	Screw		31/12/2013		BT12-010-07/14
8	4	69220047	Pressblade kit		31/12/2013		BT12-010-07/14
9	1	F1073377	Blade				
10	1	69220020	Guard				
11	2	69220022	Spring				
12	13	F1073317	Plate				
13	13	YF0582091	Blade				
14	1	69220016	Shoe			SX; LEFT	
15	11	F0582688	Tooth (Double)				
16	12	F1073321	Spacer				BT12-010-07/14
17	1	F0582738	Tooth (Single)				
18	28	YN0886600	Rivet				
19	1	YF1073384	Blade				
20	1	YF1073376B	Clutch driver				
21	1	N6433900	Screw				
22	2	YF1073364	Valve				
23	1	YN6262200	Screw				
24	2	3806063	Screw				
25	7	3819013R	Grower				
26	1	F1073378R	Blade				
27	2	F1073261	Rivet				
28	2	69220024	Complete slide				
29	8	3806070R	Screw				
30	8	320000028R	Nut				
31	8	3916010R	Washer				BT12-010-07/14
32	4	N1462800	Nut				BT12-010-07/14
33	4	N6314900	Screw				BT12-010-07/14
34	4	LS621102	Support	01/01/2014			BT12-010-07/14
35	8	N6333300	Screw	01/01/2014			BT12-010-07/14
36	4	69220047	Pressblade kit	01/01/2014			BT12-010-07/14

esm universal 102/122 clip clap

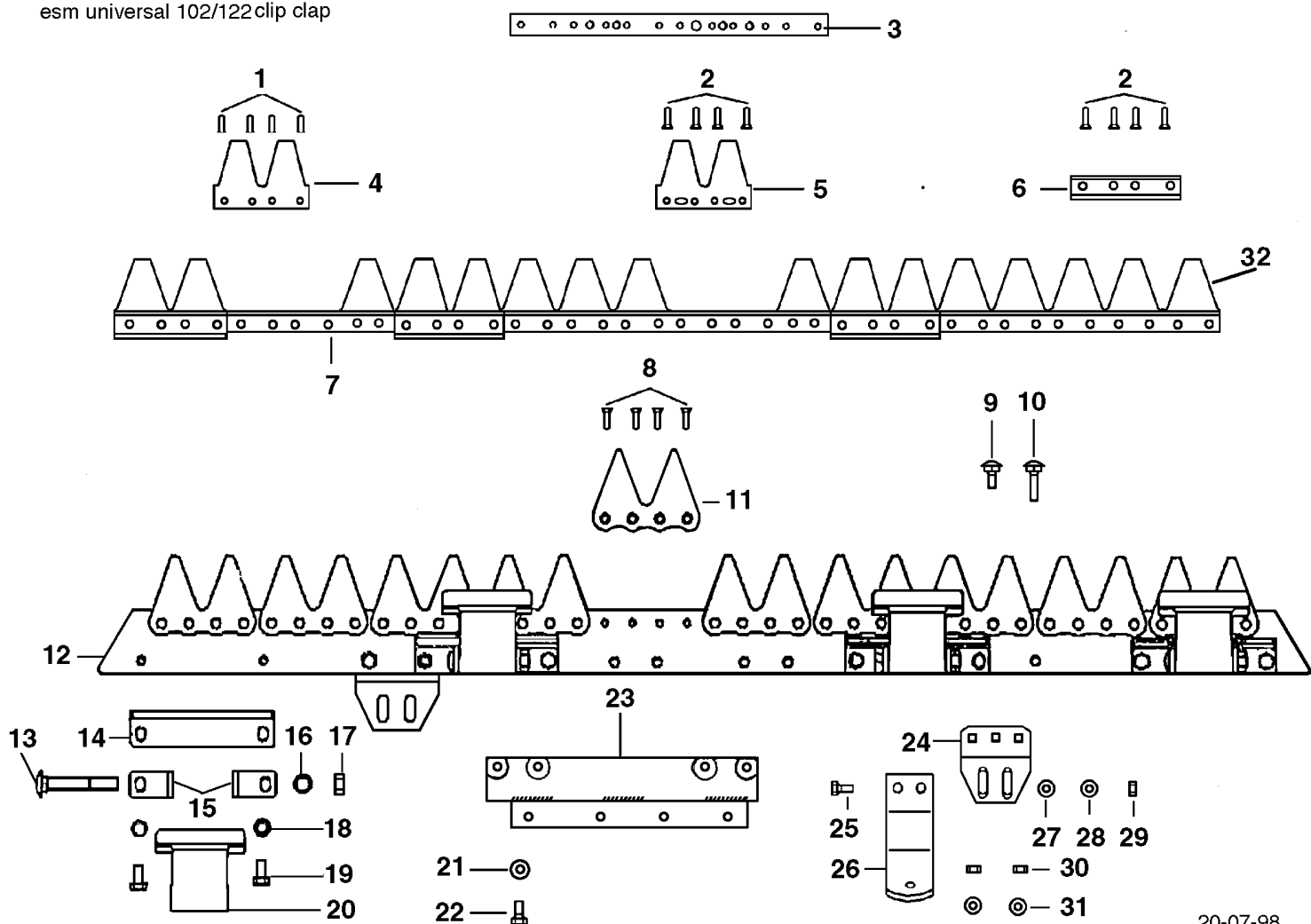

20-07-98

Ref.Nu	Qty	Part number	Description	Validity from	Validity till	Notes	Bulletin
1	1	R1504705	Rivet				
2	1	R1504706	Rivet				
3	1	F1073501	Plate				
4	1	F1073451	Shear blade (Double)				
5	1	F1073452	Shear blade (Double)				
6	1	F1073453	Slide				
7	1	F1073468	Shear blade			122 cm	
7	1	F1073502	Back (Blade)			102 cm	
8	1	N0892500	Rivet				
9	-		Not available for this product				
10	-		Not available for this product				
11	1	F1073456	Tooth (Double)				
12	1	F1073506	Back (Bar)			122 cm	
12	1	F1073505	Back (Bar)			102 cm	
13	1	F1073462	Screw				
14	1	F1073458	Plate				
15	1	F1073459	Bracket				
16	-		Not available for this product				
17	1	N1464800	Nut				
18	-		Not available for this product				
19	1	3806063	Screw				
20	1	F1073457	Pusher				
21	1	YN4365400	Washer				
22	1	YN6254600	Screw				
23	1	F1073401	Connection plate				
24	1	F1073430	Attachment (Sole)				
25	1	3806067R	Screw				
26	1	F1073428	Sole				
27	1	3916008R	Washer				
28	1	YN4365400	Washer				
29	1	R1504723	Nut				
30	-		Not available for this product				
31	-		Not available for this product				
32	1	F1073468	Shear blade			122 cm	
32	1	YF1073467	Shear blade			102 cm	

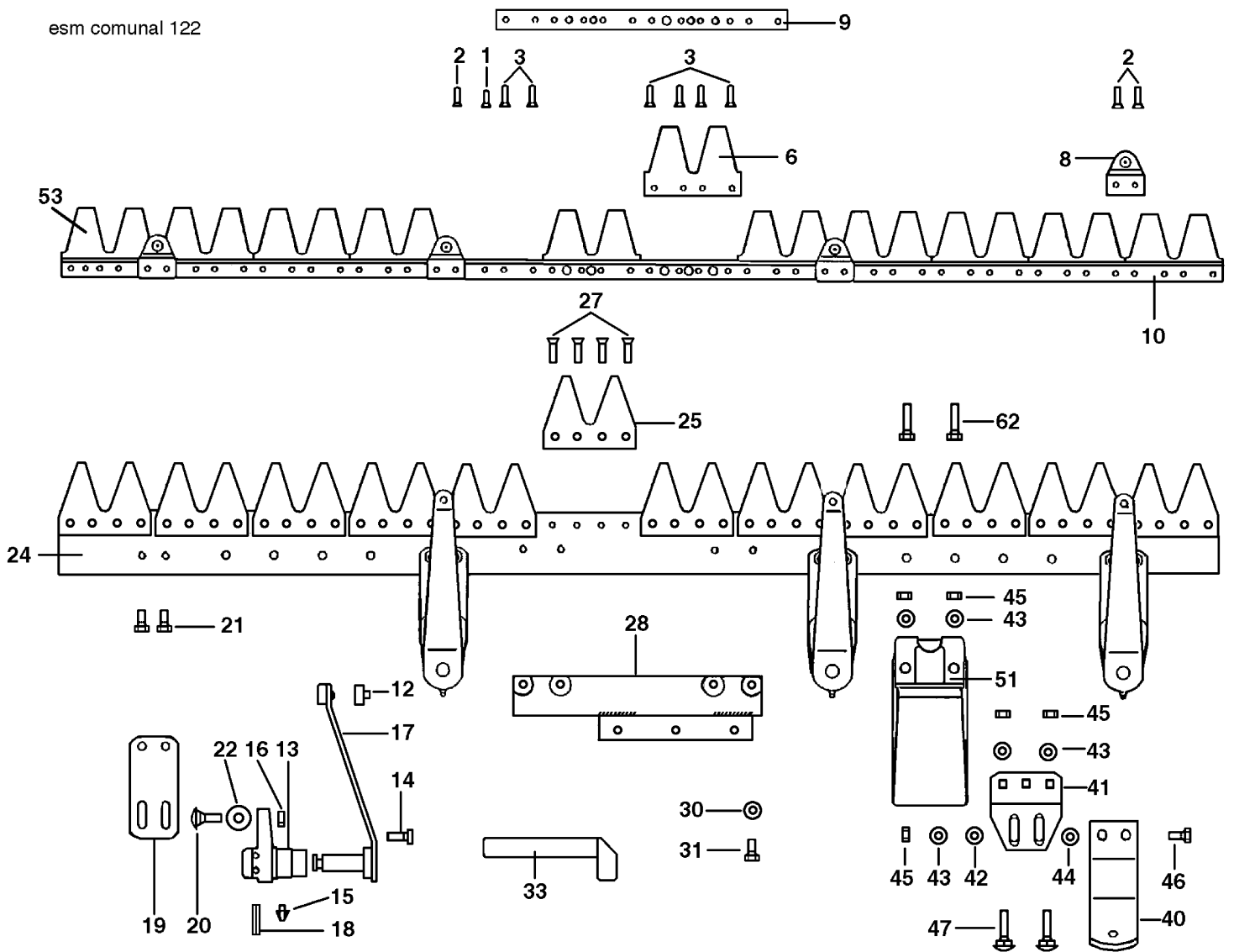

Ref.Nu	Qty	Part number	Description	Validity from	Validity till	Notes	Bulletin
1	1	R1504705	Rivet				
2	1	R1504706	Rivet				
3	1	F1073441	Rivet				
6	1	R1504709	Shear blade (Double)				
8	1	R1504764	Support				
9	1	F1073438	Plate				
10	1	YF1073409	Shear blade			122 cm	
12	1	R1504773	Bushing				
13	1	R1504768	Support				
14	1	R1504769	Screw				
15	1	R1504770	Nipple				
16	1	R1504723	Nut				
17	1	R1504772	Swing arm				
18	1	R1504771	Pin				
19	1	F1073436	Plate				
20	1	F1073442	Screw				
21	1	N6249300	Screw				
22	1	R1504776	Washer				
24	1	F1073417	Back (Bar)			122 cm	
25	1	F1073422	Tooth (Double)				
27	1	N0892500	Rivet				
28	1	F1073401	Connection plate				
30	1	YN4365400	Washer				
31	1	YN6254600	Screw				
33	1	F1073415	Lever (Fitting)				
40	1	F1073428	Sole				
41	1	F1073430	Attachment (Sole)				
42	1	3916008R	Washer				
43	1	YN4365400	Washer				
44	1	F1073443	Washer				
45	1	R1504723	Nut				
46	1	3806067R	Screw				
47	1	R1504720	Screw				
51	1	F1073432	Slide shoe				
53	1	YF1073409	Shear blade			122 cm	
62	1	3806070R	Screw				

Movimento in bagno d'olio cod.69229025

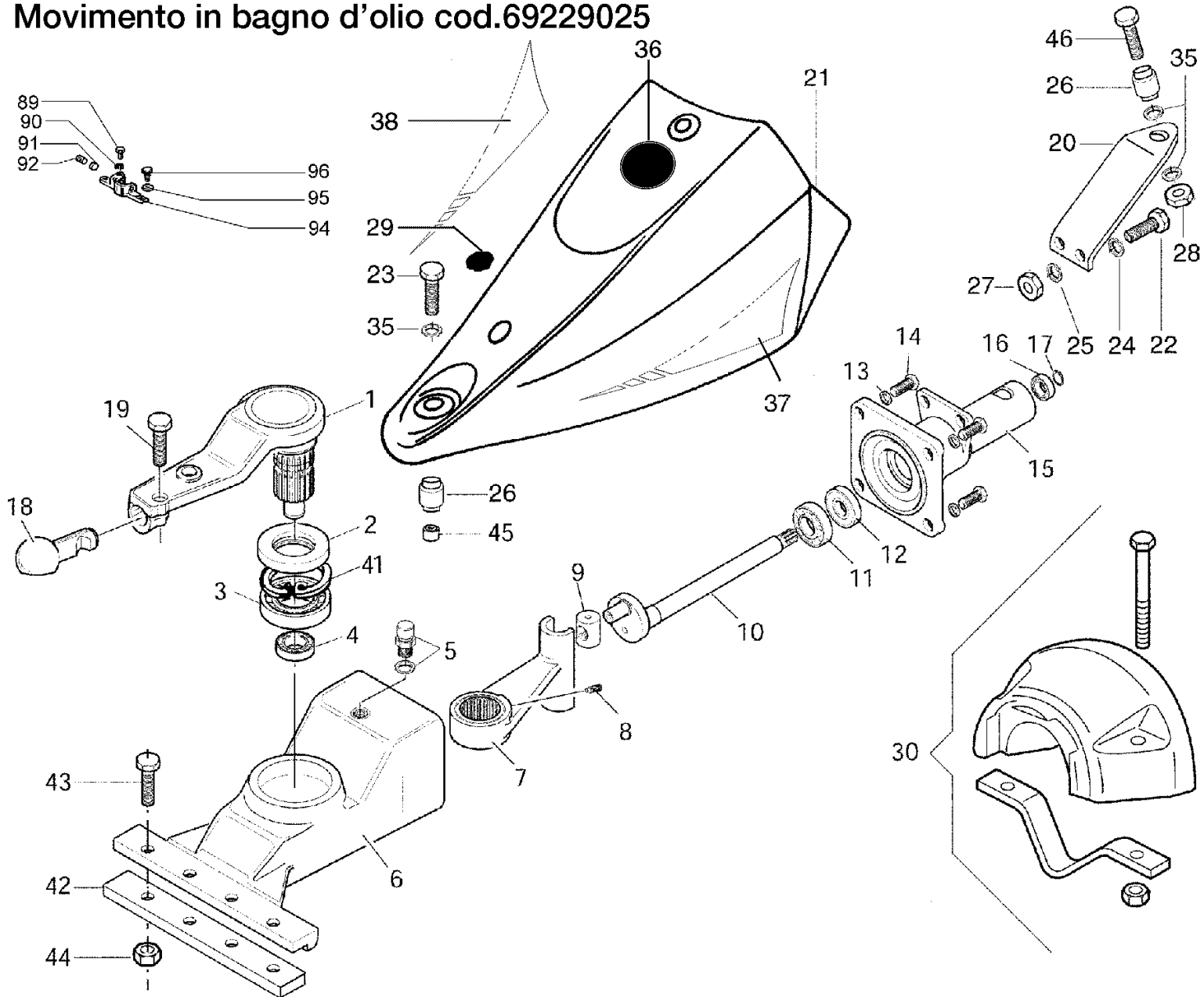

Ref.Nu	Qty	Part number	Description	Validity from	Validity till	Notes	Bulletin
1	1	F1303156	Connecting rod				
2	1	YN0222805	Ring				
3	1	YN1289200	Bearing				
4	1	YN1263701	Bearing				
5	1	YK4101420	Cap				
6	1	F1303100	Housing				
7	1	F1303102	Connecting rod				
8	1	N6251000	Screw				
9	1	YF1303106	Switch				
10	1	F1303108	Shaft				
11	1	N1272501	Bearing				
12	1	YN0210045	Ring				
13	1	3819014R	Grower				
14	1	3806094R	Screw				
15	1	F1303101	Cover				
16	1	YN1263201	Bearing				
17	1	3024020R	Seeger				
18	1	F1303155	Pin				
19	1	3806094R	Screw				
20	1	F1303125	Support				
21	1	PA001254	Hood				
22	1	3806067R	Screw				
23	1	YN6402600	Screw				
24	1	3819013R	Grower				
25	1	3916008R	Washer				
26	1	N4924000	Silent block				
27	1	320000028R	Nut				
28	1	YN1470200	Nut				
29	1	YN5265900	Cap				
30	1	L0105700	Set (Counterweight) Oil bath movement				
35	1	3916012	Washer				
36	1	68250018	Label				
37	1	68910014	Mark			Su richiesta; Upon request	
38	1	68910015	Mark			Su richiesta; Upon request	
41	1	N0140800	Seeger				
42	1	L0081100	Washer				
43	1	YN6332800	Screw				
44	1	YN1463650	Nut				
45	1	F1303133	Spacer				
46	1	N6399710	Screw				
89	1	YN6262200	Screw				
90	1	3819013R	Grower				
91	1	YF1073364	Valve				
92	1	N6433900	Screw				
94	1	YF1073363B	Clutch driver				
95	1	3819013R	Grower				
96	1	3806063	Screw				

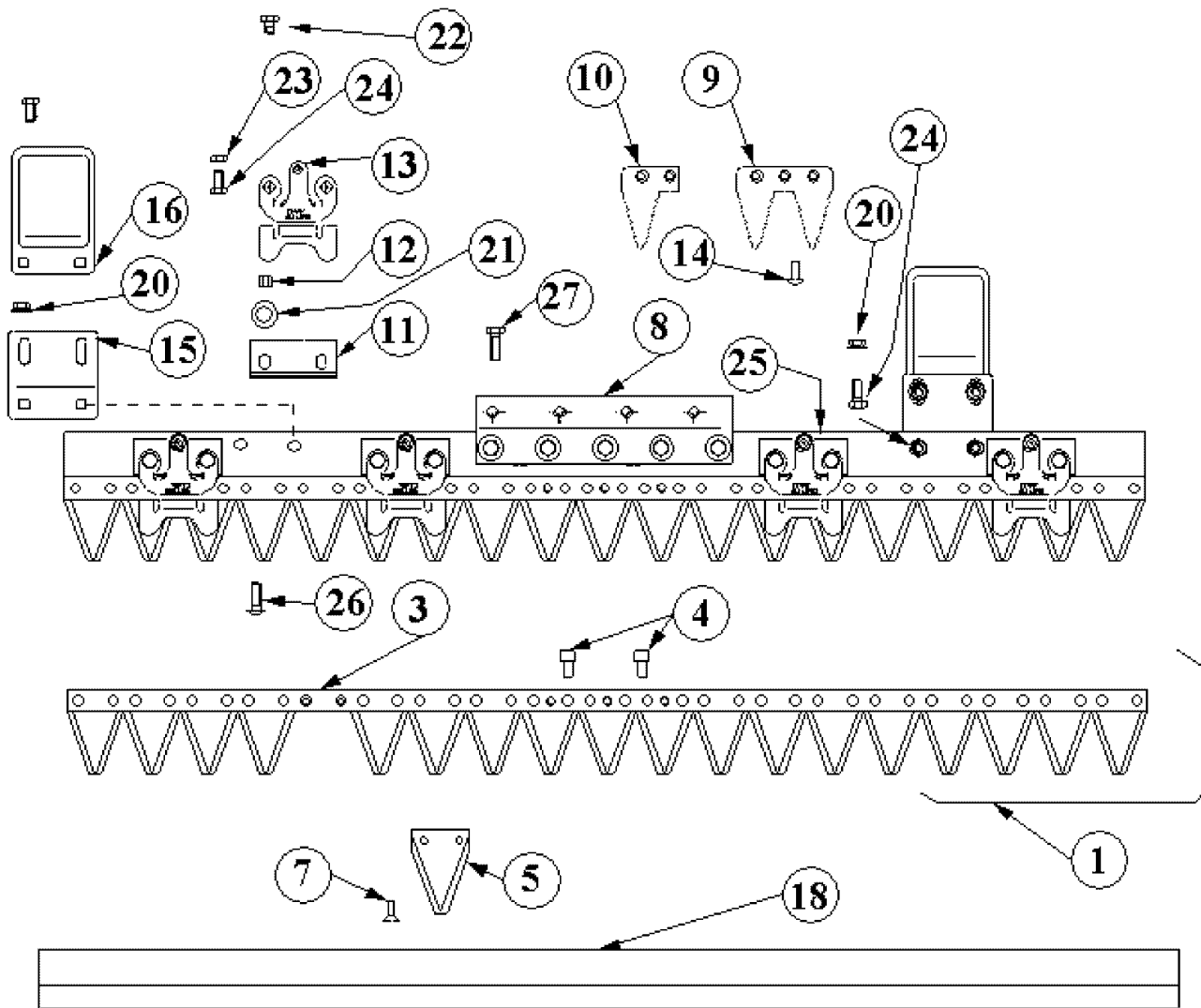

Ref.Nu	Qty	Part number	Description	Validity from	Validity till	Notes	Bulletin
1	1	YLS471906	Complete Blade			97 cm	
1	1	YLS472306	Complete Blade			117 cm	
1	1	YLS472506	Complete Blade			127 cm	
1	1	YLS472906	Complete Blade			147 cm	
3	1	LS3419225	Tube				
4	1	LS625231	Pin				
5	19	LS310067	Blade			3 fori; 3 holes	
7	36	LS213611	Rivet				
8	1	LS627027	Plate				
9	9	LS623122	Tooth (Double)			Dente doppio; Double tooth	
10	1	LS623125	Plate			Dente singolo; Singolo tooth	
11	6	LS621139	Blades support				
12	12	LS621144	Spacer				
13	6	LS621230	Press blade				
14	24	LS215619	Rivet				
15	2	LS621136	Support				
16	2	LS621172	Sliding block				
18	1	LS625056	Guard 97 cm			97 cm	
18	1	LS625061	Guard cm 117			117 cm	
18	1	LS625062	Guard cm 127			127 cm	
18	1	LS625064	Guard cm 147			147 cm	
20	8	LS7060008	Nut				
21	12	3916008R	Washer				
22	12	LS7000810	Screw				
23	6	320000028R	Nut				
24	4	LS7190825	Screw				
25	1	LS626923	Plate			97 cm	
25	1	LS626918	Plate			117 cm	
25	1	LS626924	Plate			127 cm	
25	1	LS626925	Plate			147 cm	
26	12	LS7190822	Screw				
27	5	3806063	Screw				

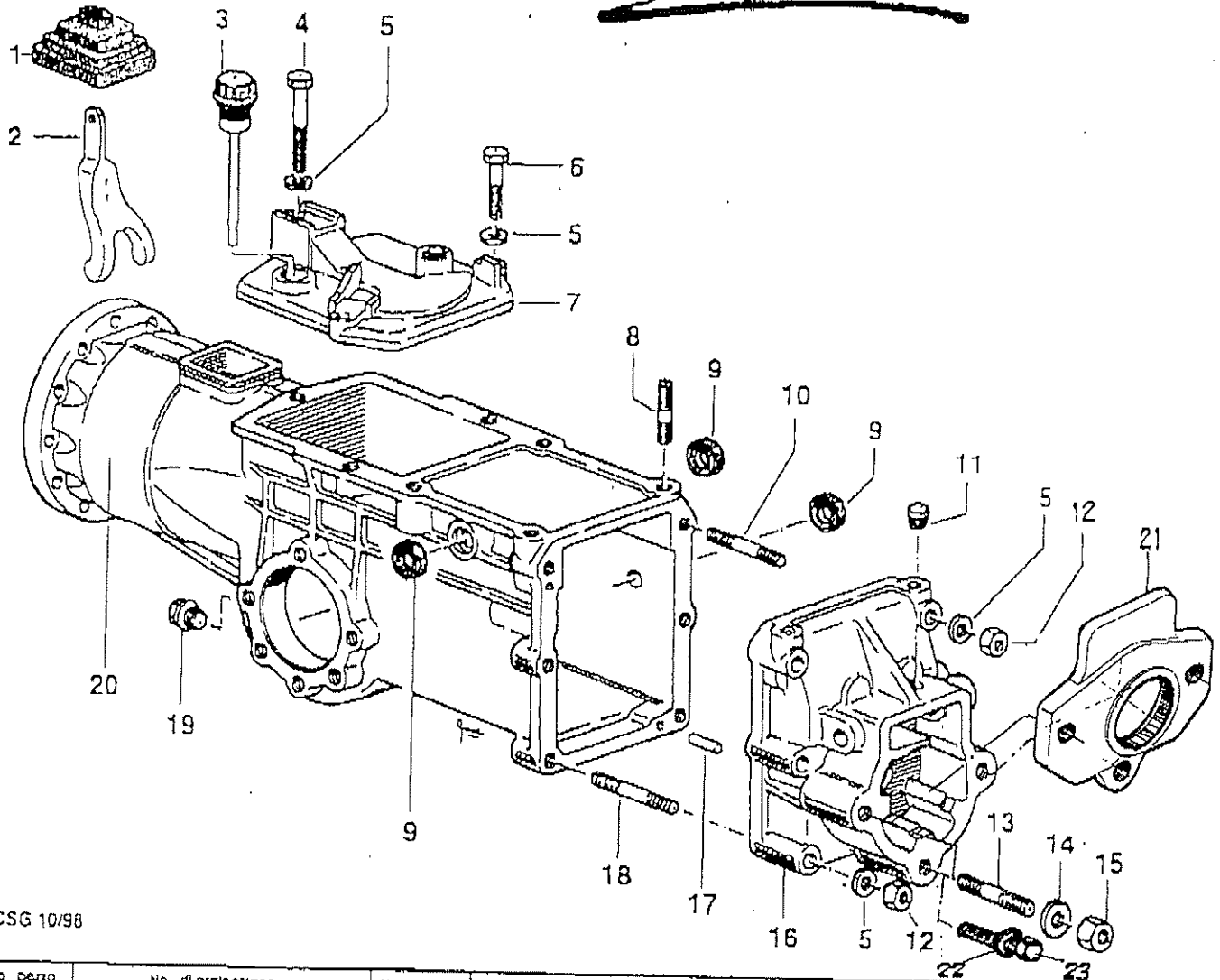

CSG 10/98

No. pezzo No. nimm No. pièce No. END No. pieza	No. di ordinazione Part No. No. de commande Bestell - Nr. No. de pedido	No. pezzo No. piece No. pièce No. END No. pieza	No. di ordinazione Part No. No. de commande Bestell - Nr. No. de pedido	No. pezzo No. piece No. pièce No. END No. pieza	No. di ordinazione Part No. No. de commande Bestell - Nr. No. de pedido
1	F75.1646	17	N5.1243.00 6x20mm		
2	F75.0011	18	N3.8257.00		
3	F129.0819	19	N5.2540.00		
4	N6.2944.00	20	F129.0801		
5	N4.3654.00	21	F129.0820		
6	N6.2741.00	* 13	N3.8662.00 3866200		
7	F129.0818 (411)	22	N4.3845.60		
	F129.0802 (410)	23	N6.3879.50		
8	N3.8125.00				
9	N2030.00 14x22x4				
10	N3.8245.00				
11	F75.0835				
12	N1.4585.00				
* 13	N3.8615.00 19/2x30				
14	N4.3877.00 K 430.2510				
15	N1.4705.00				
16	F129.0817				

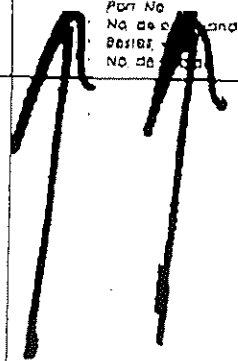

HAFOG
 Salg. Service. Fabrikation. Import
 Lyngager 5-9 2805 Brandby
 Telefon 43 98 66 11. Fax 43 28 66 25

Segnalazioni di validità
 Usage code
 Signalements de validité
 Gültigkeitsvermerk
 Indicación de validez

FICHES



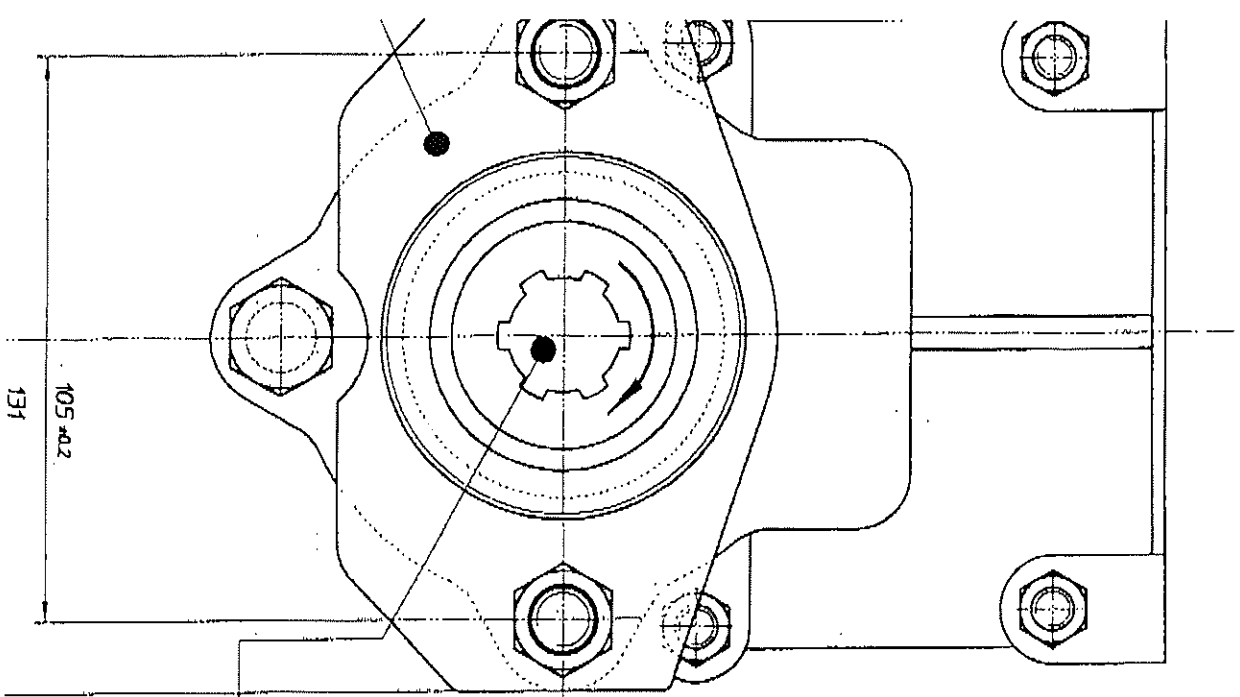

Scanalato UN221

Centro ruota

12.5

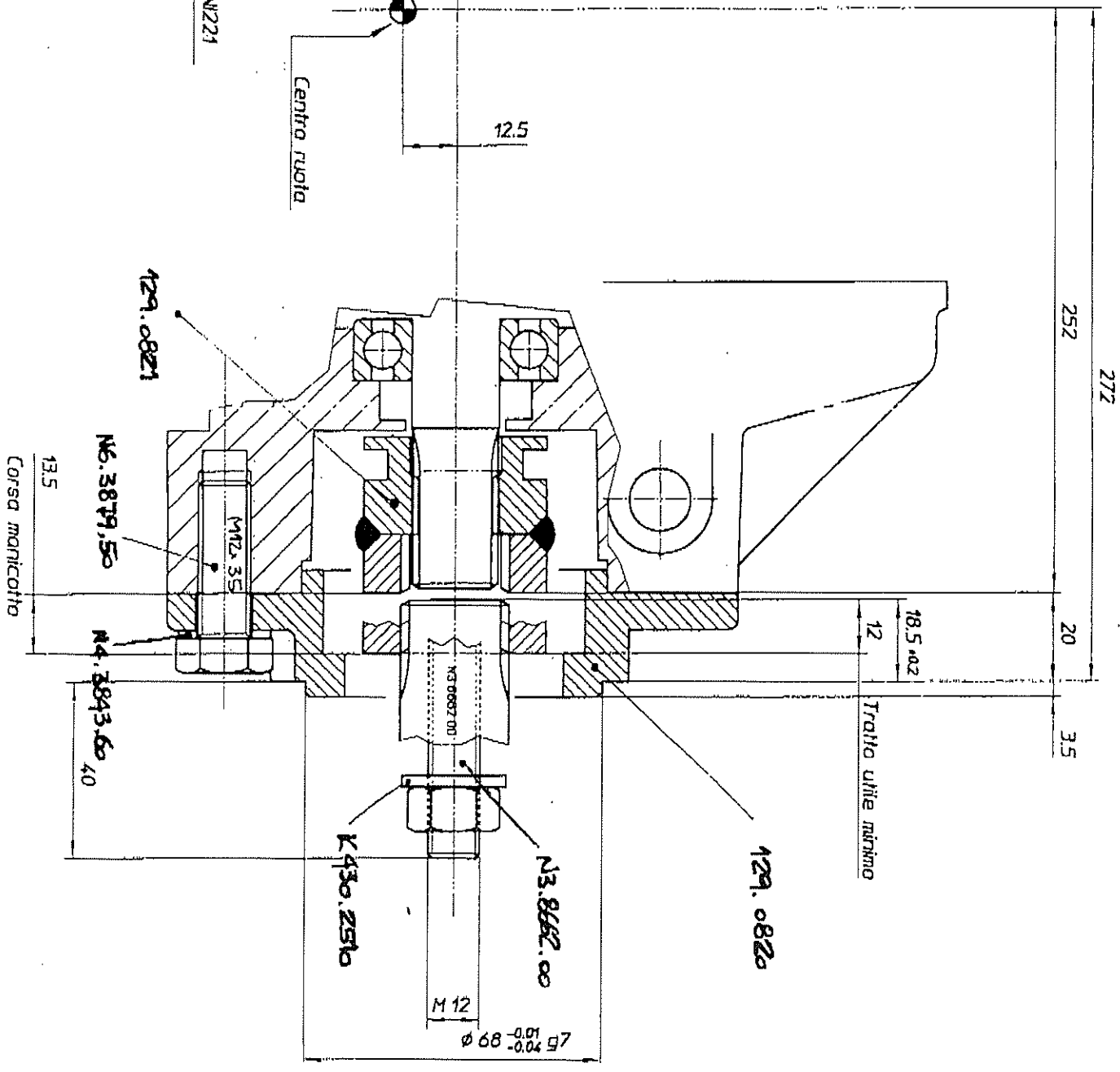

69219013 - 69219008 - 69219012

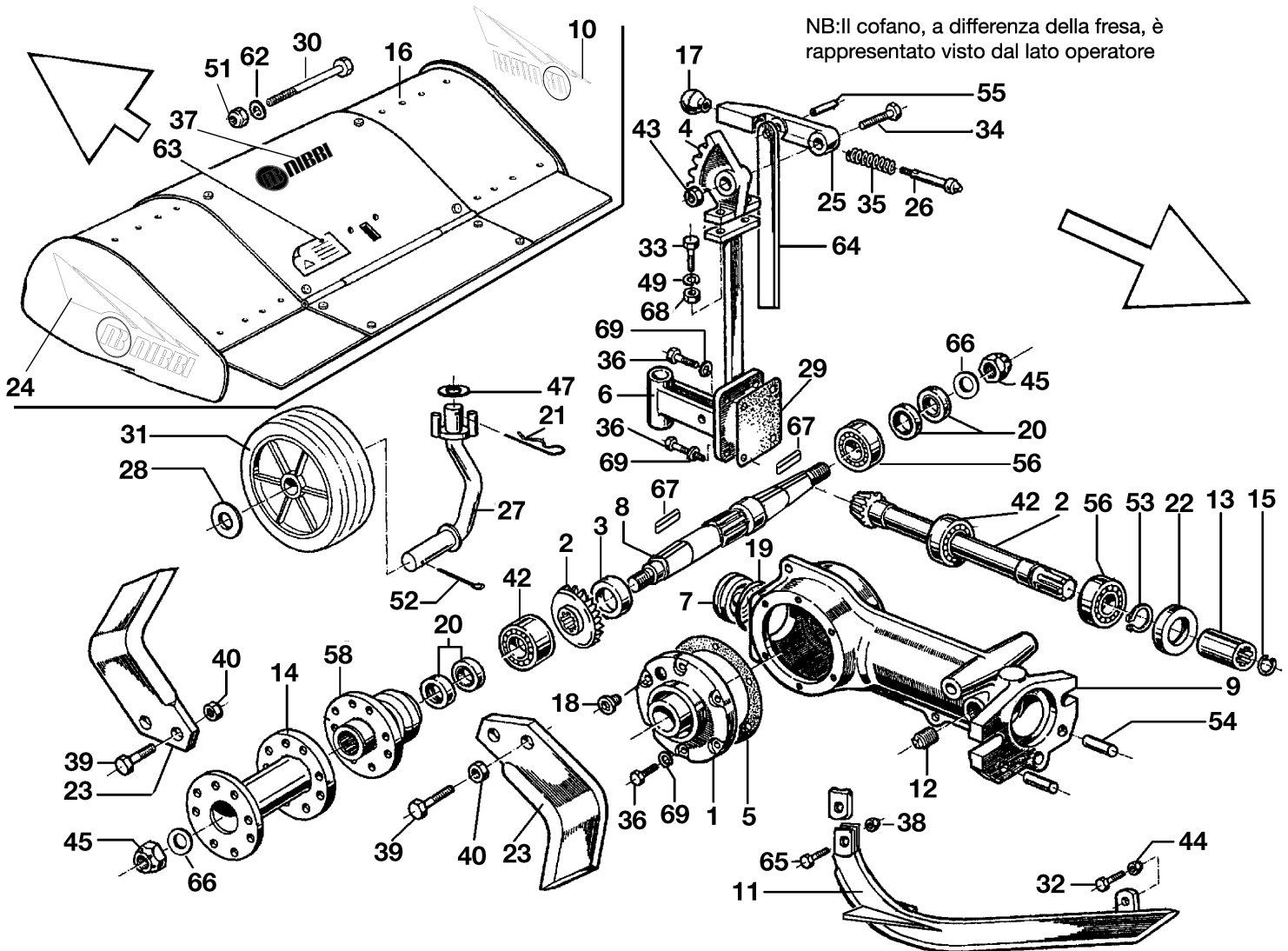

Ref.Nu	Qty	Part number	Description	Validity from	Validity till	Notes	Bulletin
1	1	K1101060	Cover				
2	1	K4806930	Set bevel gear				
3	1	K4801310	Spacer				
4	1	K4302350	Sector				
5	1	K1101100	Gasket				
6	1	K4808008	Support (Wheel)				
7	1	K4302520	Cap				
8	1	K4808060	Shaft				
9	1	K1101070	Arm				
10	1	68330029	Mark			Su richiesta; Upon request; DX; RIGHT	
11	1	F0015613	Cutter tool				
12	1	K8535002	Cap				
13	1	K1101080	Joint				
14	1	69210038	Spacer				BT12-002- 11/10
15	1	028200019	Ring				
16	1	PA001873	Hood			60+40 cm; Rosso; Red	
16	1	PA001872	Hood			70+60 cm; Rosso; Red	
16	1	PA001860	Hood			80+60 cm; Rosso; Red	
17	1	K8211001	Knob				
18	1	K8536002	Cap				
19	1	K7035045	O-ring				
20	1	N0209200	Ring				
21	1	N1054500	Cotter pin				
22	1	N0210045	Ring				
23	1	R0000138	Cutters kit			Per fresa 70 cm, kit composto da: F0015602, DX, 10pz + F0015603, SX, 10pz; For tiller 70 cm, set composed by: F0015602, RIGHT, 10pcs + F0015603, LEFT, 10pcs	
24	1	68330030	Mark			Su richiesta; Upon request; SX; LEFT	
25	1	K22035508	Lever				
26	1	K2203560	Piston pin				
27	1	K3501830	Support				
28	1	3916020	Washer				
29	1	K1101230	Gasket				
30	1	N6417235	Screw				
31	1	K1102480	Wheel				
32	1	3806067R	Screw				
33	1	YN6335900	Screw				
34	1	N6399710	Screw				
35	1	K7903026	Spring				
36	1	N6254500	Screw				
37	1	68610007	Mark			Su richiesta; Upon request	
38	1	N1458800	Nut				
39	1	N6262100	Screw				
39	1	N6274000	Screw				
40	1	N1463500	Nut	06/2009			
42	1	N1270751	Bearing				
43	1	K7272009	Nut				
44	1	K7275003	Nut				
45	1	N1482500	Nut			DX; RIGHT	
45	1	N1482600	Nut			SX; LEFT	
47	1	3916020	Washer				
49	1	3819014R	Grower				
51	1	YN1470200	Nut				
52	1	YN1060200	Cotter pin				
53	1	YN0118500	Seeger				
54	1	K8504014	Pin				
55	1	K8503039	Pin				
56	1	YN1270701	Bearing				
58	1	K4808050	Support				
62	1	3916012	Washer				
63	1	F0015577	Mark (Danger)			Su richiesta; Upon request	
64	1	F0015612	Rod				
65	1	3806065	Screw				

66	1	N4418000	Washer
67	1	YN0652200	Key
68	1	N1464600	Nut
69	1	N4364350	Washer

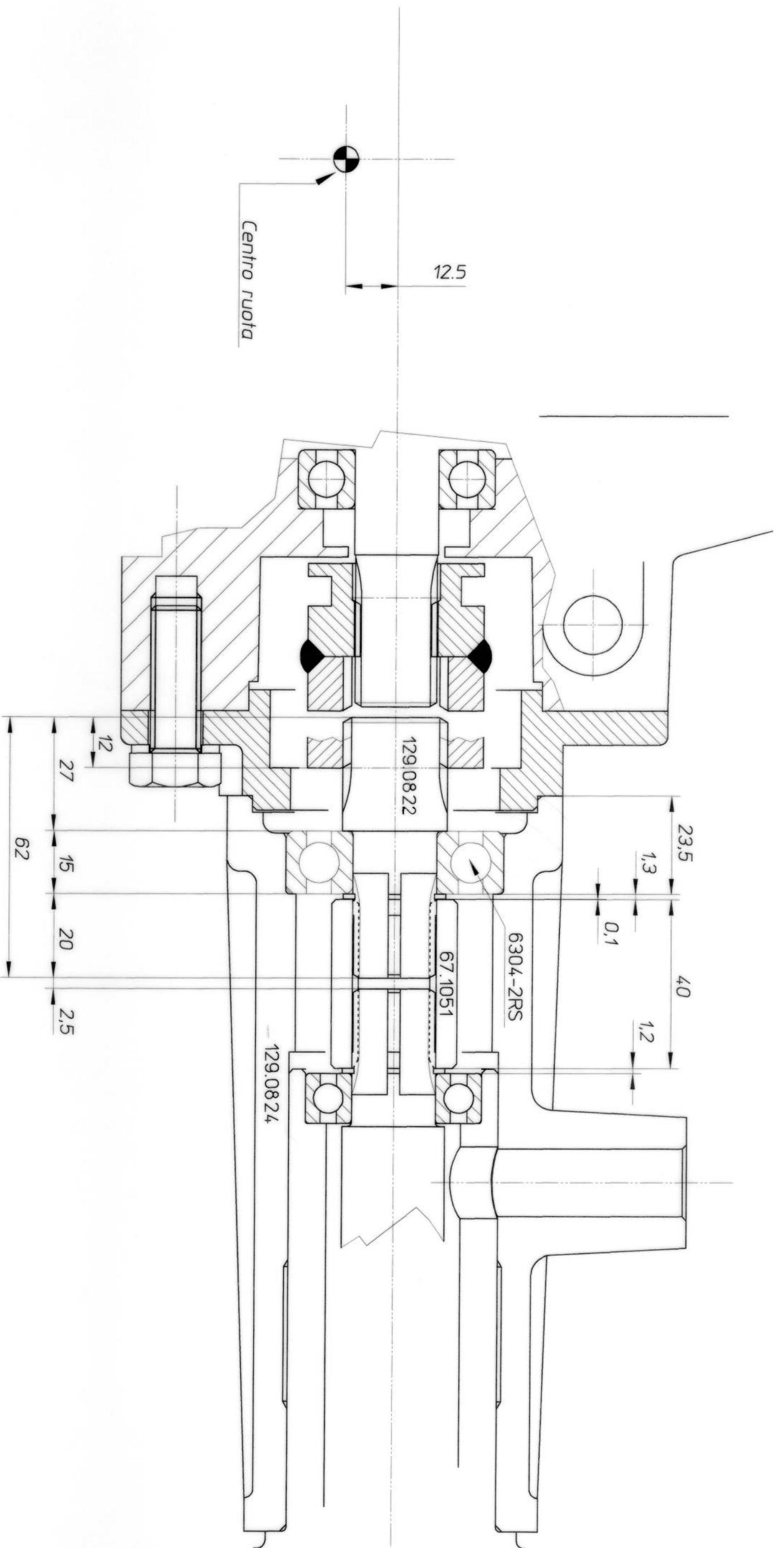

Imodi		Data		Oggetto modifica		Firma		Controllo	
● CARATTERISTICA CRITICA		● CARATTERISTICA IMPORTANTE		NESSUN SIMBOLO		● CARATTERISTICA NORMALE			
Materiale:	UNI:	Tolleranze generali	Grezzi	Lungh. e diametri $\pm 0.5\%$ max $\pm 1\text{mm}$	Spess. 10% con minimo di 1mm	Angoli $\pm 2^\circ$	Lavorati	Lungh. e diam. fino a 18 ± 0.15	da 18 a 80 ± 0.25 , > 80 ± 0.40
Stato:	UNI:	Denominazione:							
Tratt. Term.:	UNI:	Appl. flang. MAK6/7 SU KAM4/5 per MBO							
Tratt. prof. superf.:	UNI:	Gruppo:	Macchina:						
Resistenza (kg/mm ²):	UNI:	Durezza HRC: \pm							
Logo: YARBE		REGGIO EMILIA		ITALY		Disegno N°:		129.00000.00	
						Scala: 1:1		Disegnato da: Gazzotti F.	
						N° pezzi:		Controllato da:	
						Data: 06/07/00			

TECNICO • TECHNICAL	●
RICAMBI • SPARE PARTS	●
INFORMAZIONI • INFORMATION	

GRUPPO • GROUP	12
NR • NO	006
DATA • DATE	02-14

GENERALE - RICAMBI - GARANZIA General - Spares - Warranty	-1-	ACCESSORI Accessories	-2-	PRODOTTI DI COMPLEMENTO Other products	-6-	MOTOZAPPE Rotary tillers	-9-
TRINCIASARMENTI Flail mowers	-10-	TRANSPORTER	-11-	MOTOCOLTIVATORI Rotary cultivators	-12- ●		

I **MODELLI: Motocoltivatori BRIK 1 - BRIK 3 - KAM 4 - KAM 5**

OGGETTO: Leva comando frizione

DESCRIZIONE: Miglioramento prodotto. Modificato il sistema di blocco sulla leva frizione.

INTERCAMBIABILITÀ: Sì, utilizzando il kit cod.68320199R. Particolari singoli, no.

DISPONIBILITÀ RICAMBI: La leva premodifica verrà fornita ad esaurimento mentre pulsante di blocco premodifica e relativa molla continuano ad essere disponibili.

DECORRENZA: 11/08/13, matr.B043246134 (BRIK 1 - BRIK 3); 18/08/13, matr.B053329010 (KAM 4 - KAM 5)

NOTE: A seguito della modifica, il codice kit leva completo prende la variante alfabetica "A".

GB **MODELS: BRIK 1 - BRIK 3 - KAM 4 - KAM 5 rotary cultivators**

SUBJECT: Control clutch lever

DESCRIPTION: Product improvement. Changed the locking system on the clutch lever.

INTERCHANGEABILITY: Yes, using the kit p/n 68320199R. Single parts, no.

PARTS AVAILABILITY: Old lever will be supplied until end of the stock while the old locking button and relative spring continue to be available to spare.

CUT-IN DATE: 11/08/13, serial n° B043246134 (BRIK 1 - BRIK 3); 18/08/13, serial n° B053329010 (KAM 4 - KAM 5)

NOTES: After the improvement, the p/n for complete kit lever get the letter "A".

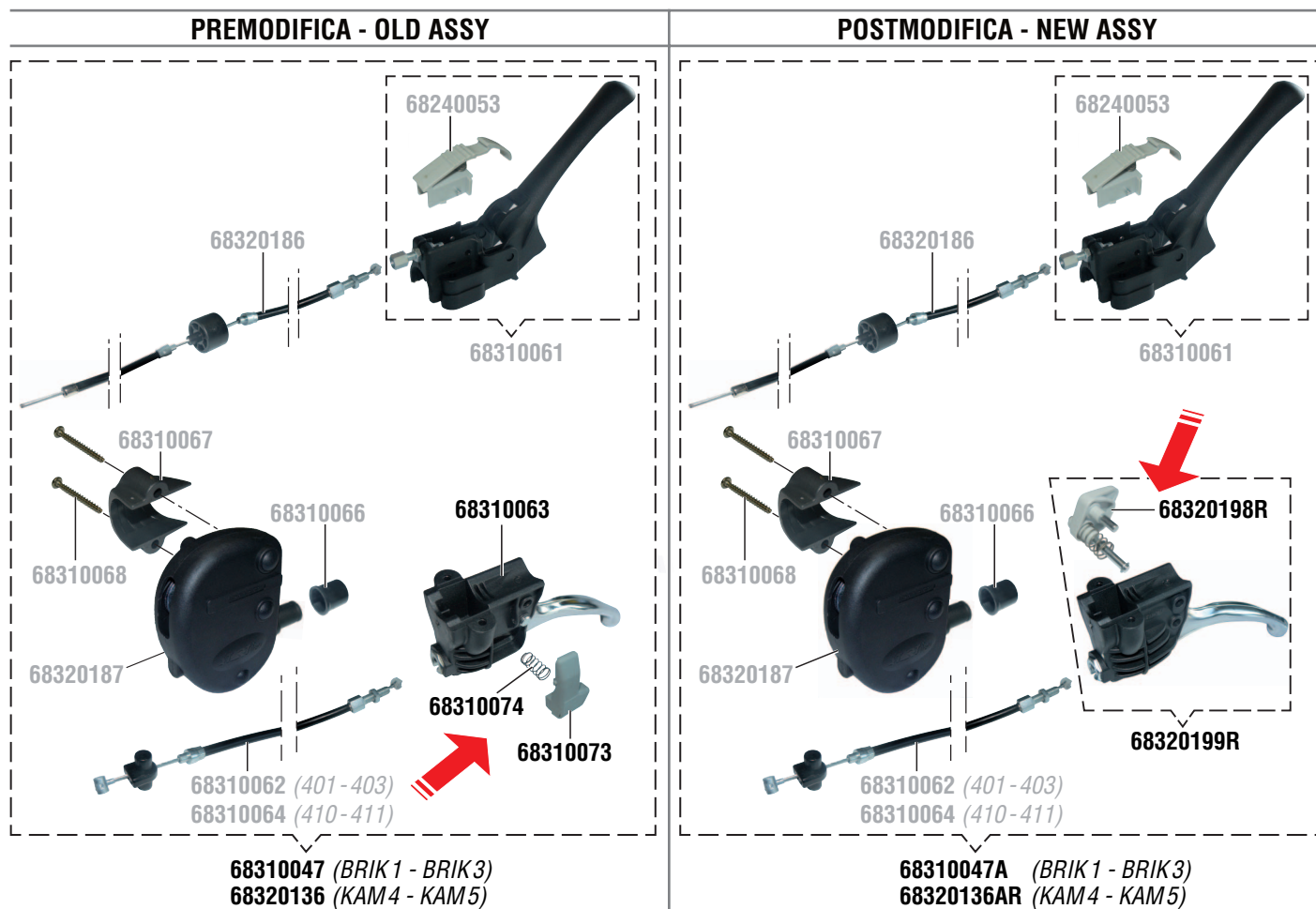

TECNICO • TECHNICAL	●	GRUPPO • GROUP	12
RICAMBI • SPARE PARTS	●	NR • NO	008
INFORMAZIONI • INFORMATION		DATA • DATE	03-14

GENERALE - RICAMBI - GARANZIA General - Spares - Warranty	-1-	ACCESSORI Accessories	-2-	PRODOTTI DI COMPLEMENTO Other products	-6-	MOTAZAPPE Rotary tillers	-9-
TRINCIASARMENTI Flail mowers	-10-	TRANSPORTER	-11-	MOTOCOLTIVATORI Rotary cultivators	-12-		

I **MODELLI: Motocoltivatori MAK 16 - BRIK 1 - BRIK 3 - KAM 4 - KAM 5 - KAM 5 HF - KAM 5 JUNIOR**

OGGETTO: Interruttore arresto motore

DESCRIZIONE: Introdotta un nuovo interruttore d'arresto motore. Compatibile su modelli equipaggiati con motori Honda GX 270 / GX 340 versioni T1 e H (cavetto singolo), Honda GX160 - GC160 - GX200, Emak K800H, Kohler CH270 - CH395.

INTERCAMBIABILITÀ: Sì.

DISPONIBILITÀ RICAMBI: L'interruttore premodifica verrà fornito ad esaurimento; il cavetto premodifica continua ad essere disponibile.

DECORRENZA: (MAK 16) 03/03/14, matr.B034100001 (BRIK 1 - BRIK 3) 08/11/13, matr.B043456555
(KAM 4 - KAM 5 - KAM 5 HF - KAM 5 JUNIOR) 01/11/13, matr.B053449246

GB **MODELS: MAK 16 - BRIK 1 - BRIK 3 - KAM 4 - KAM 5 - KAM 5 HF - KAM 5 JUNIOR Rotary cultivators**

SUBJECT: Engine stop switch

DESCRIPTION: Introduced a new engine stop switch. Compatible on models equipped with Honda GX 270 / GX 340 version T1 e H (single cable), Honda GX160 - GC160 - GX200, Emak K800H, Kohler CH270 - CH395 engine.

INTERCHANGEABILITY: Yes.

PARTS AVAILABILITY: Old switch will be supplied until end of the stock; the old cable continue to be available.

CUT-IN DATE: (MAK 16) 03/03/14, serial n° B034100001 (BRIK 1 - BRIK 3) 08/11/13, serial n° B043456555
(KAM 4 - KAM 5 - KAM 5 HF - KAM 5 JUNIOR) 01/11/13, serial n° B053449246

PREMODIFICA - OLD ASSY

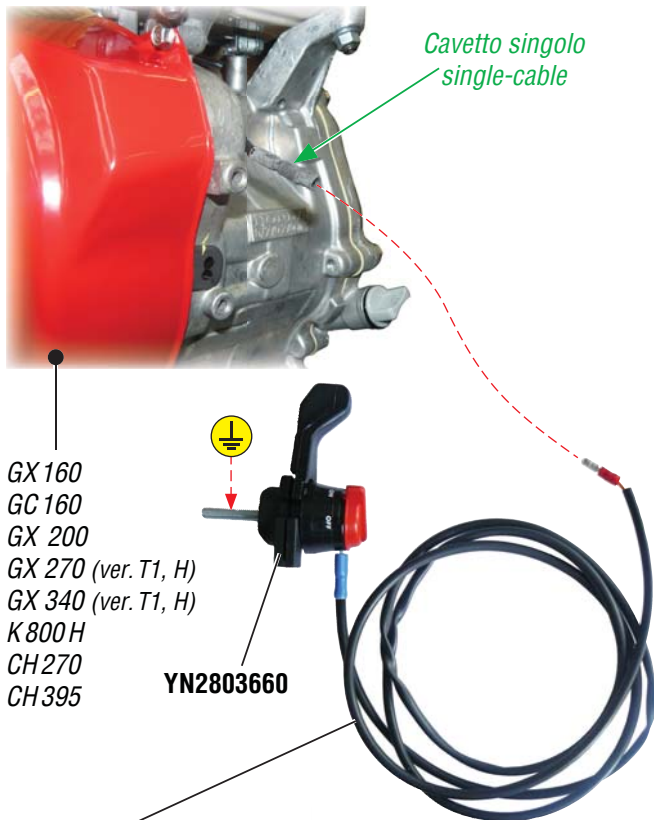

(MAK 16) **68330113**
(BRIK 1 - BRIK 3 - KAM 4 - KAM 5 - KAM 5 HF - KAM 5 JUNIOR) **68310059**

POSTMODIFICA - NEW ASSY

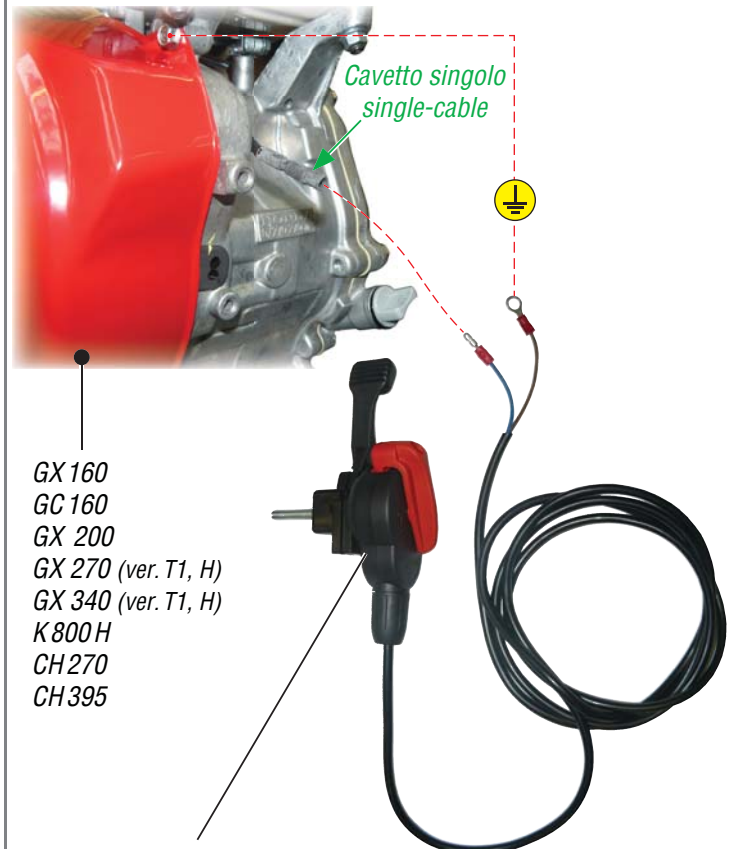

(MAK 16) **3044011R**
(BRIK 1 - BRIK 3 - KAM 4 - KAM 5 - KAM 5 HF - KAM 5 JUNIOR) **3044010R**

TECNICO • TECHNICAL	●	GRUPPO • GROUP	12
RICAMBI • SPARE PARTS	●	NR • NO	009
INFORMAZIONI • INFORMATION		DATA • DATE	05-14

GENERALE - RICAMBI - GARANZIA General - Spares - Warranty	-1-	ACCESSORI Accessories	-2-	PRODOTTI DI COMPLEMENTO Other products	-6-	MOTOZAPPE Rotary tillers	-9-
TRINCIASARMENTI Flail mowers	-10-	TRANSPORTER	-11-	MOTOCOLTIVATORI Rotary cultivators	-12-		

I

MODELLI: Motocoltivatori KAM 4 - KAM 5

OGGETTO: Selettore marce e leva

DESCRIZIONE: Per migliorare l'inserimento delle marce è stato sostituito il selettore e relative leve.

INTERCAMBIABILITÀ: No

DISPONIBILITÀ RICAMBI: Selettore e leva premodifica continuano ad essere forniti mentre i gruppi cambio verranno forniti ad esaurimento.

DECORRENZA: 14/12/13, matr.B053499349

NOTE: Nei nuovi gruppi cambio cod.68322132R / 68322133R non è compreso il kit selettore leva cod.68320209

GB

MODELS: KAM 4 - KAM 5 Rotary cultivators

SUBJECT: Gear selector switch and lever

DESCRIPTION: To improve the gear engagement we have replaced the selector switch and related levers.

INTERCHANGEABILITY: No

PARTS AVAILABILITY: Selector switch and lever premodified continue to be available to spare while the gear box assemblies will be supplied until end of the stock.

CUT-IN DATE: 14/12/13, serial n° B053499349

NOTES: On the new gear box assembly p/n 68322132R / 68322133R is not included the selector switch and lever kit p/n 68320209

PREMODIFICA - OLD ASSY

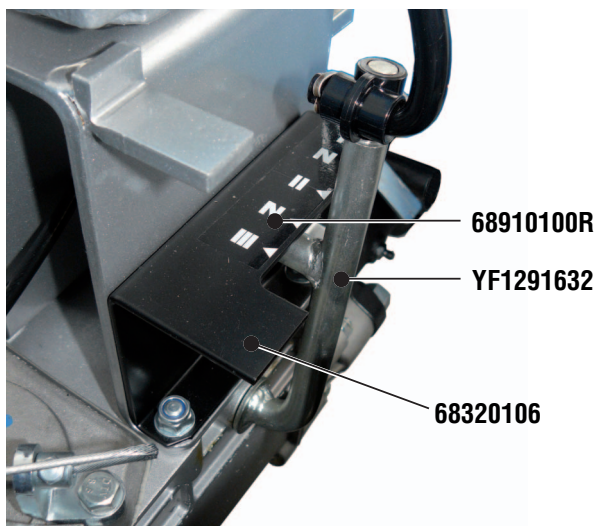

(Mod.KAM 4) Gruppo cambio /Gear box assy P/N 68322057
(Mod.KAM 5) Gruppo cambio /Gear box assy P/N 68322055R

POSTMODIFICA - NEW ASSY

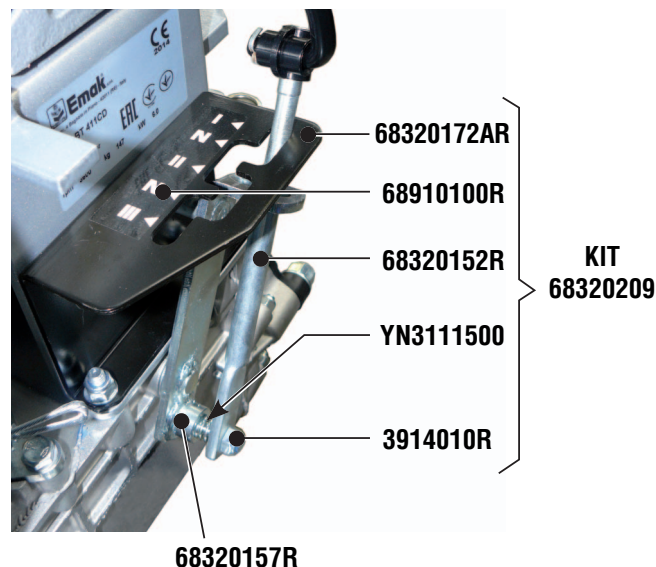

(Mod.KAM 4) Gruppo cambio /Gear box assy P/N 68322133R
(Mod.KAM 5) Gruppo cambio /Gear box assy P/N 68322132R



our power, your passion

BOLLETTINO - BULLETIN

TECNICO • TECHNICAL	
RICAMBI • SPARE PARTS	
INFORMAZIONI • INFORMATION	●

GRUPPO • GROUP	1
NR • NO	01
DATA • DATE	10-10

GENERALE - RICAMBI - GARANZIA General - Spares - Warranty	-1- ●	ACCESSORI Accessories	-2-	PRODOTTI DI COMPLEMENTO Other products	-6-	MOTOZAPPE Rotary tillers	-9-
TRINCIASARMENTI Flail mowers	-10-	TRANSPORTER	-11-	MOTOCOLTIVATORI Rotary cultivators	-12-		

I **MODELLI: Motozappe - Motocoltivatori - Motofalciatrici - Transporters - Trinciasarmenti**
OGGETTO: Numero di matricola

DESCRIZIONE: Il numero di matricola identifica il modello macchina, periodo di produzione e il numero progressivo delle macchine prodotte.

GB **MODELS: Rotary tillers - Rotary cultivators - Cutterbar mowers - Transporters - Flail mowers**
SUBJECT: Serial number

DESCRIPTION: The serial number identifies the machine model, date of production and progressive number of produced machines.

ESEMPIO / EXAMPLE

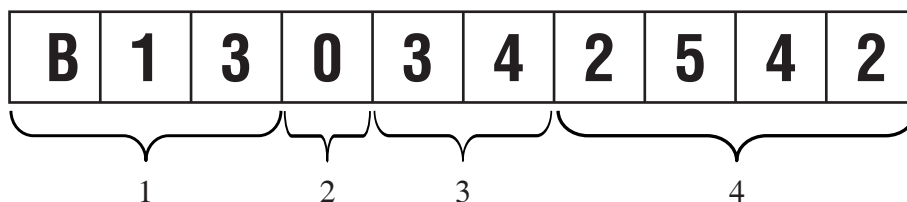

1 = MODELLO/MODEL
 3 = SETTIMANA/WEEK

2 = ANNO/YEAR
 4 = NUMERO PROGRESSIVO/
 PROGRESSIVE NUMBER

PREFISSO/PREFIX	MODELLO/MODEL
B01	FC20/FC20L/FC30
B02	FC30M
B03	FC30H/FC30HM
B04	BRIK1/BRIK3
B05	KAM4/KAM5
B06	119
B07	106
B08	110/112
B09	115
B10	160/162
B11	NTR 270V/350V
B12	NTR 450/550/550D/1750D/2250D

PREFISSO/PREFIX	MODELLO/MODEL
B13	NTS 65/80
B14	121/122
B31	MAK16/MAK17/MAK18
B33	193/194
B34	NTS 50
B35	101/102
B39	100
B41	090
850	010

Product Information

Language	INGLESE
Nr.	10
Date	02/2012
Subject	EN-709



Compliance with standard UNI-EN-709



Rotary cultivators

The recent update of safety measures (contained in standard UNI-EN-709) called for a revision of the following product types for agricultural applications in relation to the operator safety devices:

rotary tillers
rotary cultivators

In the case of rotary cultivators, the main changes prompted by the update concern the following functional areas of the machine:

1. Control system
2. Soil working tool
3. Speed change
4. Braking system

Emak has met these requirements by implementing dedicated technical solutions and redesigning the layout of certain controls.

TECHNICAL SOLUTIONS

• **Control system:** Irrespective of the type of transmission installed on the rotary cultivators, the machine must have a hold-to-run control, configured in such a way that:

- when the operator releases the levers, the engine does not shut off
- activation of the lever occurs in two distinct stages.

New features were required in order to keep the engine running even when the operator is absent and to avoid involuntary activation of the controls, notably:

A) a new clutch type, known as a reverse clutch. This is a normally disengaged clutch (drive not transmitted between engine and gearbox) that makes it possible to keep the engine running when the control levers are not operated, both with a gear engaged and in neutral. Moreover, when the levers are released the rotary cultivator remains braked thanks to a safety brake device installed on the clutch (Fig.1). This supplementary brake is applied whenever the clutch is disengaged, thereby avoiding uncontrolled movement of the machine and protecting the operator's safety.

B) a new system for activation of the reverse clutch, called QUICK-START and composed of:

1) Dual control lever comprising:

- an upper holding lever operated by means of two separate movements (Fig.2 A) and with force of less than 27.5 N (approximately 3 kg);
- a lower drive lever, operated with just one hand (Fig.2 B) and equipped with manual locking and automatic release (Fig.2 C) thus maximizing operator comfort.

2) Rocker: this device is tripped when both levers have been activated by the operator, consequently controlling engagement of the clutch. (Fig.3)

3) Spring shock absorber: composed of a steel cylinder and a preloaded spring; manages simultaneous operation of the control levers and transmits the necessary force for operation of the clutch. (Fig.4) In synthesis, the use of the QUICK START system means that simultaneous activation of the two levers enables the load to be transferred from the rocker to the shock absorber, thereby causing the clutch to engage and transmit drive between engine and gearbox.

It follows that the current Motor Stop system will no longer be installed on the rotary cultivators.

Fig. 1



Fig. 2

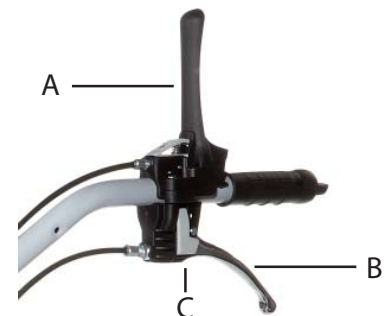

Fig. 3

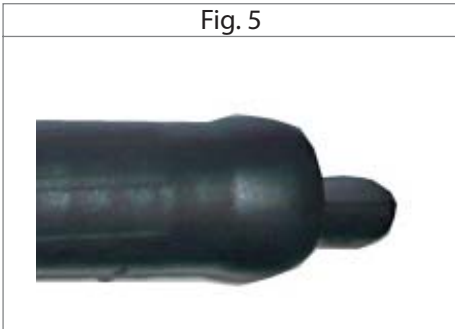

Fig. 4



TECHNICAL SOLUTIONS

Fig. 5



• **Soil working tool:**

The standard specifies that, under any given operating condition, the minimum distance between the operator and the tool shall be between 600 mm and 700 mm. Accordingly, spacer knobs have been added to the ends of the handgrips; this modification also improves ergonomic efficiency during operations.

Fig. 6

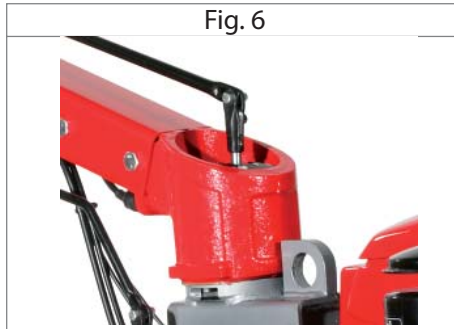

• **Speed change:**

The ground speed of certain rotary cultivators in the range has been revised in order to comply with the new limits imposed by the standard (8 km/h forward and 3 km/h reverse).

Fig. 7



• **Braking system:**

All rotary cultivators, with the exception of models BRIK 1 and BRIK 3, will be equipped as standard with service brakes that can be operated directly from a lever on the handlebar (a double lever for models with differential), allowing immediate immobilisation of the machine when necessary (such as stopping on a gradient or negotiation of obstacles).

Rotary cultivators				
Model	QUICK-START	Speed change comply	Soil working tool	Braking system
BRIK 1	●	-	●	-
BRIK 3	●	-	●	-
KAM 4	●	●	●	●
KAM 5	●	●	●	●
MAK 16	●	●	●	●



It's an Emak S.p.A. trademark Member of the Yama Group
Via E.Fermi, 4 • 42011 Bagnolo in Piano (Reggio Emilia) - Italy
Tel. +39 0522 956611 • Fax +39 0522 951555
info@mynibbi.com • www.mynibbi.com

