



our **power**, your **passion**

NIBBI MAK 4

(OP TIL ÅRG. 2009)



Henrik A. Fog A/S

Lyngager 5-11

2605 Brøndby

Tel 43966611

Fax 43266624

reservedele@hafog.dk

www.hafog.dk

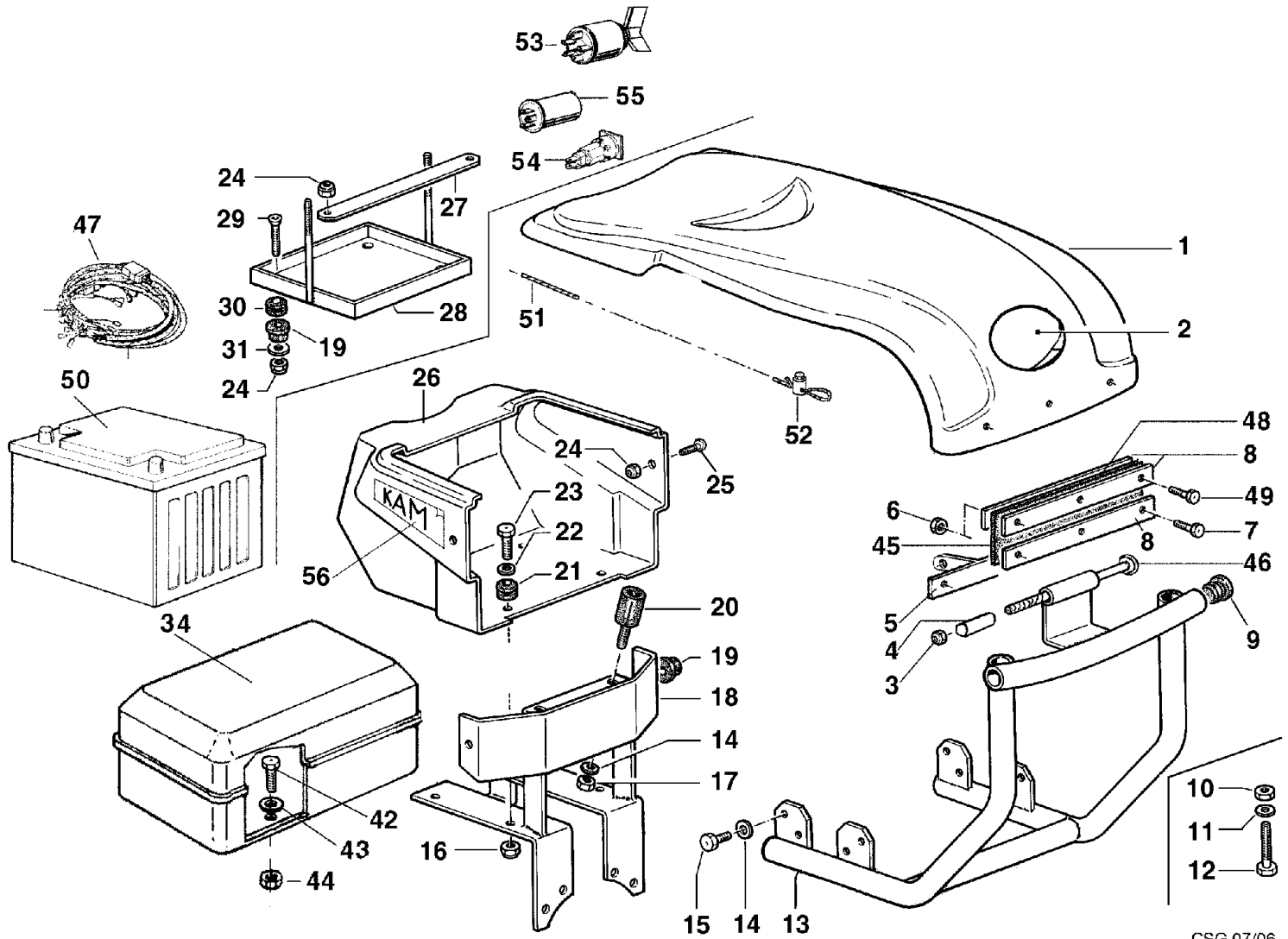

CSG 07/06

Ref.Nu	Qty	Part number	Description	Validity from	Validity till	Notes	Bulletin
1	1	68322106	Hood				
2		-	Not available for this product				
3	1	YN1458020	Nut				
4	1	F1292146	Spacer				
5	1	68320059	Support				
6	1	3914006R	Nut				
7	1	3906016	Screw				
8	1	68320055	Main board				
9	1	N5267400	Cap				
10	1	006000091R	Nut			15LD400; 15LD400 AE; ACT280; 15LD315; 15LD350; 15LD350 AE; Honda GX270; Kohler CS8.5; Kohler CS8.5 AE	
10	1	3914010R	Nut			Honda GX160	
11	1	YN4376400	Washer			15LD400; 15LD400 AE; ACT280; 15LD315; 15LD350; 15LD350 AE; Honda GX270; Kohler CS8.5; Kohler CS8.5 AE	
11	1	3916008R	Washer			Honda GX160	
12	1	3806067R	Screw			Honda GX160	
12	1	YN6335900	Screw			Honda GX160	
12	1	N6294400	Screw			15LD400; 15LD400 AE; 15LD315; 15LD350; 15LD350 AE	
12	1	N6354300	Screw			ACT280; Honda GX270; Kohler CS8.5; Kohler CS8.5 AE	
13	1	68320058	Support			Honda GX160	
13	1	F1292124	Support			Honda GX270	
13	1	68320068	Support			Kohler CS8.5; Kohler CS8.5 AE	
13	1	F1292175	Support			15LD400; 15LD400 AE	
13	1	F1292108	Support			ACT280	
13	1	68320064	Support			15LD315; 15LD350	
13	1	F1292115	Support			IM359; A349; CA340	
13	1	F1292109	Support			ALN330	
14	1	YN4365400	Washer			IM359; IM349; IM359 AE; A349 AE; CA340	
15	1	3806063	Screw			IM359; IM349; IM359 AE; A349 AE; CA340	
16	1	3914010R	Nut			15LD400; 15LD400 AE; ACT280; 15LD315; 15LD350; 15LD350 AE; Honda GX270; Kohler CS8.5; Kohler CS8.5 AE; IM359; IM349; IM359 AE; A349 AE; CA340	
17	1	320000028R	Nut				
18	1	68320007	Support	04/2004		15LD400; 15LD400 AE	
18	1	68320044	Support			Honda GX160	
18	1	F1292104	Support			Honda GX270; IM359; IM349; IM359 AE; A349 AE; CA340; 15LD315; 15LD350; 15LD350 AE; ACT280	
19	1	F0752170	Buffer				
20	1	F0752159	Silent block				
21	1	N0400530	Grommet			15LD400; 15LD400 AE; ACT280; 15LD315; 15LD350; 15LD350 AE; Honda GX270; Kohler CS8.5; Kohler CS8.5 AE; IM359; IM349; IM359 AE; A349 AE; CA340	
22	1	3916008R	Washer			15LD400; 15LD400 AE; ACT280; 15LD315; 15LD350; 15LD350 AE; Honda GX270; Kohler CS8.5; Kohler CS8.5 AE; IM359; IM349; IM359 AE; A349 AE; CA340	
23	1	3806067R	Screw			15LD400; 15LD400 AE; ACT280; 15LD315; 15LD350; 15LD350 AE; Honda GX270; Kohler CS8.5; Kohler CS8.5 AE; IM359; IM349; IM359 AE; A349 AE; CA340	
24	1	3914006R	Nut			15LD400; 15LD400 AE; ACT280; 15LD315; 15LD350; 15LD350 AE; Honda GX270; Kohler CS8.5; Kohler CS8.5 AE; IM359; IM349; IM359 AE; A349 AE; CA340	
25	1	N6218600	Screw			15LD400; 15LD400 AE; ACT280;	

				15LD315; 15LD350; 15LD350 AE; Honda GX270; Kohler CS8.5; Kohler CS8.5 AE; IM359; IM349; IM359 AE; A349 AE; CA340
26	1	68320026	Hood	Avviamento elettrico; Electric starter
26	1	68320024	Hood	15LD400; 15LD400 AE; ACT280; 15LD315; 15LD350; 15LD350 AE; Honda GX270; Kohler CS8.5; Kohler CS8.5 AE; IM359; IM349; IM359 AE; A349 AE; CA340
27	1	F1292601	Main board	Avviamento elettrico; Electric starter; 15LD400; 15LD400 AE; 15LD315; 15LD350; 15LD350 AE; IM359; IM349; IM359 AE; A349 AE; Kohler CS8.5; Kohler CS8.5 AE
28	1	F1292600	Battery casing	Avviamento elettrico; Electric starter; 15LD400; 15LD400 AE; 15LD315; 15LD350; 15LD350 AE; IM359; IM349; IM359 AE; A349 AE; Kohler CS8.5; Kohler CS8.5 AE
29	1	N6233000	Screw	Avviamento elettrico; Electric starter; 15LD400; 15LD400 AE; 15LD315; 15LD350; 15LD350 AE; IM359; IM349; IM359 AE; A349 AE; Kohler CS8.5; Kohler CS8.5 AE
30	1	N0400530	Grommet	Avviamento elettrico; Electric starter; 15LD400; 15LD400 AE; 15LD315; 15LD350; 15LD350 AE; IM359; IM349; IM359 AE; A349 AE; Kohler CS8.5; Kohler CS8.5 AE
31	1	YN4361900	Washer	Avviamento elettrico; Electric starter; 15LD400; 15LD400 AE; 15LD315; 15LD350; 15LD350 AE; IM359; IM349; IM359 AE; A349 AE; Kohler CS8.5; Kohler CS8.5 AE
34	1	F1221601	Box	Honda GX160
42	1	3806035R	Screw	Honda GX160; Kohler CS8.5; Kohler CS8.5 AE
43	1	3916006R	Washer	Honda GX160; Kohler CS8.5; Kohler CS8.5 AE
44	1	3914006R	Nut	Honda GX160; Kohler CS8.5; Kohler CS8.5 AE
45	1	K4301960	Tire	
46	1	N6302700	Screw	
47	1	F1292606	Electric starter	15LD315; 15LD350; 15LD400
47	1	F1292605	Electric starter	LGA280
47	1	F1292603	Electric starter	IM359; A349; Kohler CS8.5
48	1	F1292170	Tire	
49	1	3806035R	Screw	
50	1	68330115	Battery	
51	1	K4804570	Cable	
52	1	YN5901000	Clamp	
53	1	N2540020	Switch	
54	1	N2552250	Warning light	
55	1	N2552370	Plug	
56		-	Not available for this product	

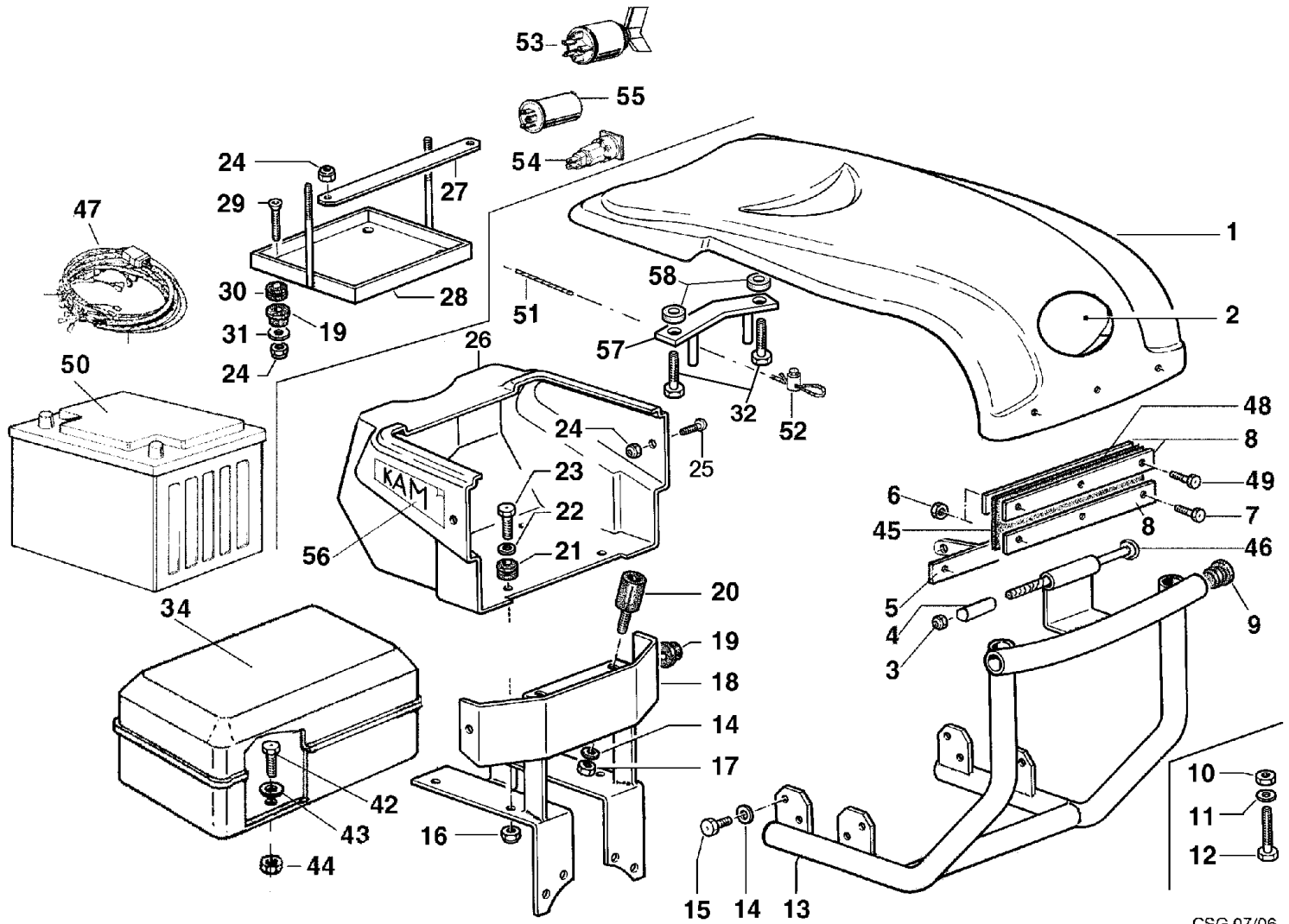

CSG 07/06

Ref.Nu	Qty	Part number	Description	Validity from	Validity till	Notes	Bulletin
1	1	68322106	Hood	SN 15044			
2	-	-	Not available for this product				
3	1	YN1458020	Nut				
4	1	F1292146	Spacer				
5	1	68320059	Support				
6	1	3914006R	Nut				
7	1	3906016	Screw				
8	1	68320055	Main board				
9	1	N5267400	Cap				
10	1	3914010R	Nut			Honda GX160	
10	1	006000091R	Nut			15LD400; 15LD400 AE; ACT280; 15LD315; 15LD350; 15LD350 AE; Honda GX270	
11	1	3916008R	Washer			Honda GX160	
11	1	YN4376400	Washer			15LD400; 15LD400 AE; ACT280; 15LD315; 15LD350; 15LD350 AE; Honda GX270	
12	1	N6294400	Screw			Honda GX160	
12	1	N6354300	Screw			ACT280; Honda GX270	
12	1	3806067R	Screw			Honda GX160	
12	1	YN6335900	Screw			15LD315; 15LD350; 15LD350 AE; 15LD400; 15LD400 AE	
13	1	68320064	Support			15LD315; 15LD350	
13	1	F1292108	Support			ACT280	
13	1	F1292109	Support			ALN330	
13	1	F1292115	Support			IM359; A349; CA340	
13	1	F1292124	Support			Honda GX270	
13	1	68320058	Support			Honda GX160	
13	1	F1292175	Support			15LD315; 15LD350; 15LD350 AE	
14	1	YN4365400	Washer			IM359; IM349; IM359 AE; A349 AE; CA340	
15	1	3806063	Screw			IM359; IM349; IM359 AE; A349 AE; CA340	
16	1	3914010R	Nut			15LD400; 15LD400 AE; ACT280; 15LD315; 15LD350; 15LD350 AE; Honda GX270; IM359; IM349; IM359 AE; A349 AE; CA340	
17	1	320000028R	Nut				
18	1	F1292104	Support			15LD400; 15LD400 AE; ACT280; Honda GX270; IM359; IM349; IM359 AE; A349 AE; CA340	
18	1	68320044	Support			Honda GX160	
18	1	68320007	Support	04/2004		15LD400; 15LD400 AE	
19	1	F0752170	Buffer				
20	1	F0752159	Silent block				
21	1	N0400530	Grommet			15LD400; 15LD400 AE; ACT280; 15LD315; 15LD350; 15LD350 AE; Honda GX270; IM359; IM349; IM359 AE; A349 AE; CA340	
22	1	3916008R	Washer			15LD400; 15LD400 AE; ACT280; 15LD315; 15LD350; 15LD350 AE; Honda GX270; IM359; IM349; IM359 AE; A349 AE; CA340	
23	1	3806067R	Screw			15LD400; 15LD400 AE; ACT280; 15LD315; 15LD350; 15LD350 AE; Honda GX270; IM359; IM349; IM359 AE; A349 AE; CA340	
24	1	3914006R	Nut			15LD400; 15LD400 AE; ACT280; 15LD315; 15LD350; 15LD350 AE; Honda GX270; IM359; IM349; IM359 AE; A349 AE; CA340	
25	1	N6218600	Screw			15LD400; 15LD400 AE; ACT280; 15LD315; 15LD350; 15LD350 AE; Honda GX270; IM359; IM349; IM359 AE; A349 AE; CA340	
26	1	68320024	Hood			15LD400; 15LD400 AE; ACT280; 15LD315; 15LD350; 15LD350 AE; Honda GX270; IM359; IM349; IM359 AE; A349 AE; CA340	
26	1	68320026	Hood			Avviamento elettrico; Electric starter	
27	1	F1292101	Main board			Avviamento elettrico; Electric starter	

27	1	F1292601	Main board	Avviamento elettrico; Electric starter; 15LD400; 15LD400 AE; 15LD315; 15LD350; 15LD350 AE; IM359; Im349; IM359 AE; A349 AE
28	1	F1292600	Battery casing	Avviamento elettrico; Electric starter; 15LD400; 15LD400 AE; 15LD315; 15LD350; 15LD350 AE; IM359; Im349; IM359 AE; A349 AE
29	1	N6233000	Screw	Avviamento elettrico; Electric starter; 15LD400; 15LD400 AE; 15LD315; 15LD350; 15LD350 AE; IM359; Im349; IM359 AE; A349 AE
30	1	N0400530	Grommet	Avviamento elettrico; Electric starter; 15LD400; 15LD400 AE; 15LD315; 15LD350; 15LD350 AE; IM359; Im349; IM359 AE; A349 AE
31	1	YN4361900	Washer	Avviamento elettrico; Electric starter; 15LD400; 15LD400 AE; 15LD315; 15LD350; 15LD350 AE; IM359; Im349; IM359 AE; A349 AE
32	2	3806035R	Screw	
34	1	F1221601	Box	Honda GX160
42	1	3806035R	Screw	Honda GX160
43	1	3916006R	Washer	Honda GX160
44	1	3914006R	Nut	Honda GX160
45	1	K4301960	Tire	
46	1	N6302700	Screw	
47	1	F1292603	Electric starter	IM359; A349
47	1	F1292606	Electric starter	15LD315; 15LD350; 15LD400
47	1	F1292605	Electric starter	LGA280
48	1	F1292170	Tire	
49	1	YN6234500	Screw	SN 15044
50	1	68330115	Battery	
51	1	K4804570	Cable	
52	1	YN5901000	Clamp	
53	1	N2540020	Switch	
54	1	N2552250	Warning light	
55	1	N2552370	Plug	
56		-	Not available for this product	
57	1	F1292206	Support	
58	1	N2400500	Washer	

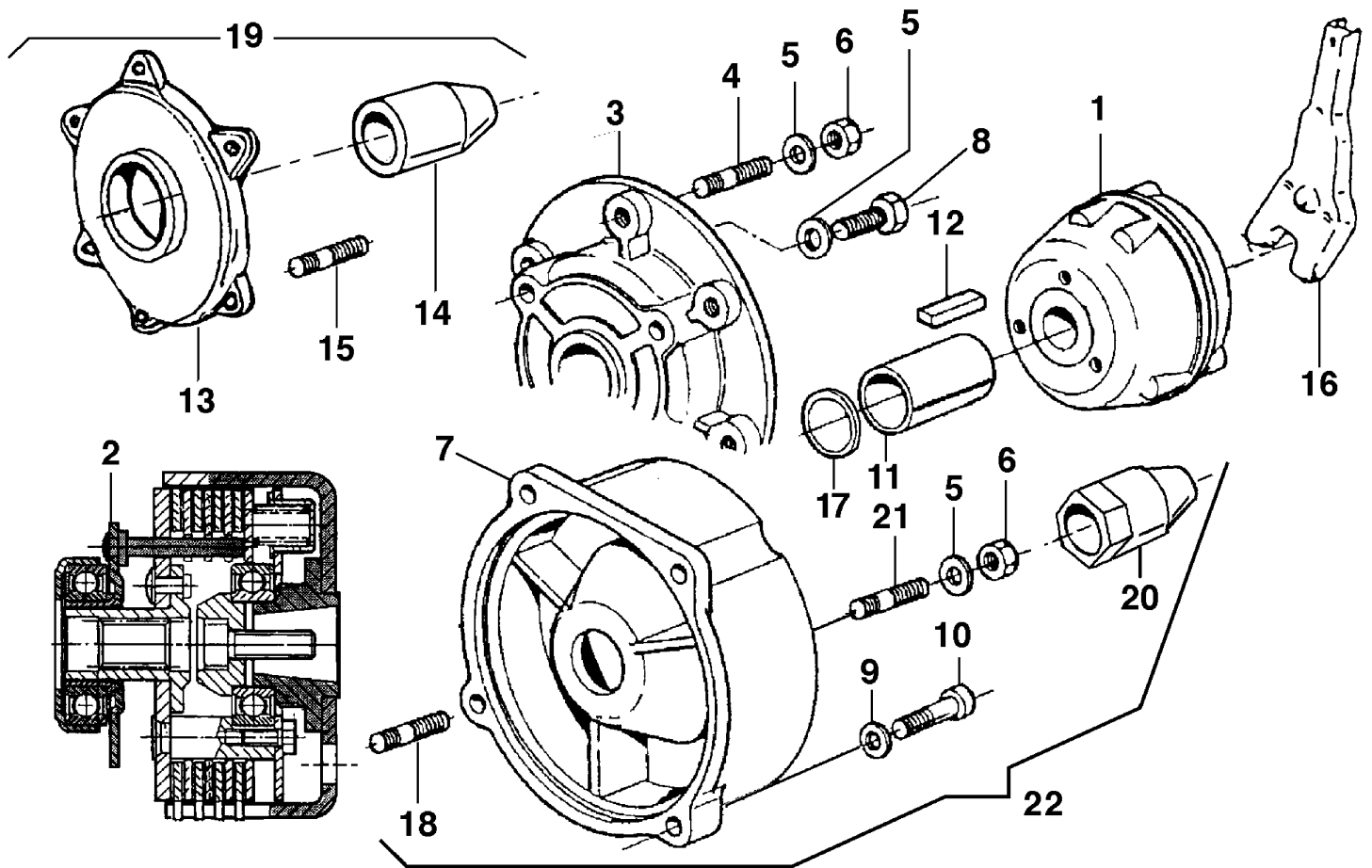

Ref.Nu	Qty	Part number	Description	Validity from	Validity till	Notes	Bulletin
1	1	YF1200016	Clutch			Honda GX160	
1	1	YF1200032	Clutch				
1	1	YF1200003	Clutch			IM359; A349; CA340	
1	1	F1200004	Clutch			ALN330; 15LD315; A220; A230	
2	1	F1200035	Multiple disk clutch			Kohler CS10	
2	1	F1200006	Multiple disk clutch			Honda GX270; Kohler CS8.5	
2	1	YF1090002	Multiple disk clutch			15LD400; 15LD440; 15LD400 AE (da- from 03/2004); ACT280; 6LD400; 6LD400 AE; 6LD435	
2	1	F1090007	Multiple disk clutch			Yanmar L70; Yanmar L100; 15LD350; 15LD400 AE; 15LD400; 15LD440 (fino-until 03/2004)	
3	1	68310038A	Flange			Honda GX160	
3	1	F1050027G	Flange			Honda GC160; B&S; Tecumseh	
4	1	N3812500	Stud			Honda GX160	
5	1	YN4365400	Washer			Honda GX270; Kohler CS8.5; 15LD400; 15LD440; 15LD400 AE (da- from 03/2004); Honda GX160	
6	1	320000028R	Nut			Honda GX270; Kohler CS8.5; 15LD400; 15LD440; 15LD400 AE (da- from 03/2004); Honda GX160	
7	1	68320117	Flange			Honda GX270; Kohler CS8.5; 15LD400; 15LD440; 15LD400 AE (da- from 03/2004)	
8	1	YN6243980	Screw			Honda GX160	
9	1	YN4376400	Washer			Honda GX270; Kohler CS8.5; 15LD400; 15LD440; 15LD400 AE (da- from 03/2004)	
10	1	N6309790	Screw			Honda GX270; Kohler CS8.5; 15LD400; 15LD440; 15LD400 AE (da- from 03/2004)	
11	1	F1050036	Spacer			Vecchia frizione; Old clutch; Honda GX270; Kohler CS8.5	
11	1	F1050028	Spacer			Honda GX160; 15LD400 AE; 15LD400; 15LD440 (fino-until 03/2004)	
12	1	YN0643410	Key			Honda GX160	
12	1	N0648090	Key			Frizione monoblocco; Clutch single- block; Honda GX270; Kohler CS8.5	
12	1	N0648080	Key			Frizione con distanziale; Clutch with spacer; Honda GX270; Kohler CS8.5	
13	1	F1210001	Spacer			ALN330; 15LD315; A220; A230; Yanmar L70; Yanmar L100; 15LD350; 15LD400 AE; 15LD400; 15LD440; (fino 03/2004)	
14	1	F1210002	Spacer			ALN330; 15LD315; A220; A230; Yanmar L70; Yanmar L100; 15LD350; 15LD400 AE; 15LD400; 15LD440; (fino 03/2004)	
15	1	N3815300	Stud			Motore senza distanziale; Engine without spacer	
15	1	K8236004	Stud			ALN330; 15LD315; A220; A230; Yanmar L70; Yanmar L100; 15LD350; 15LD400 AE; 15LD400; 15LD440; (fino 03/2004)	
16	1	YF0750011	Lever				
17	1	N5002870	Washer			Honda GX160	
18	1	N3815300	Stud			15LD400; 15LD440; 15LD400 AE; (da- from 03/2004)	
19	1	P1200020	Spacer unit			ALN330; 15LD315; A220; A230; Yanmar L70; Yanmar L100; 15LD350; 15LD400 AE; 15LD400; 15LD440; (fino 03/2004)	
20	1	F1290007	Spacer			15LD400; 15LD440; 15LD400 AE; (da- from 03/2004)	
21	1	N3815300	Stud			15LD400; 15LD440; 15LD400 AE; (da- from 03/2004); Kohler CS8.5	
21	1	N3812500	Stud			Honda GX270; Kohler CS8.5	
22	1	P1200021	Spacer unit			15LD400; 15LD440; 15LD400 AE; (da- from 03/2004)	

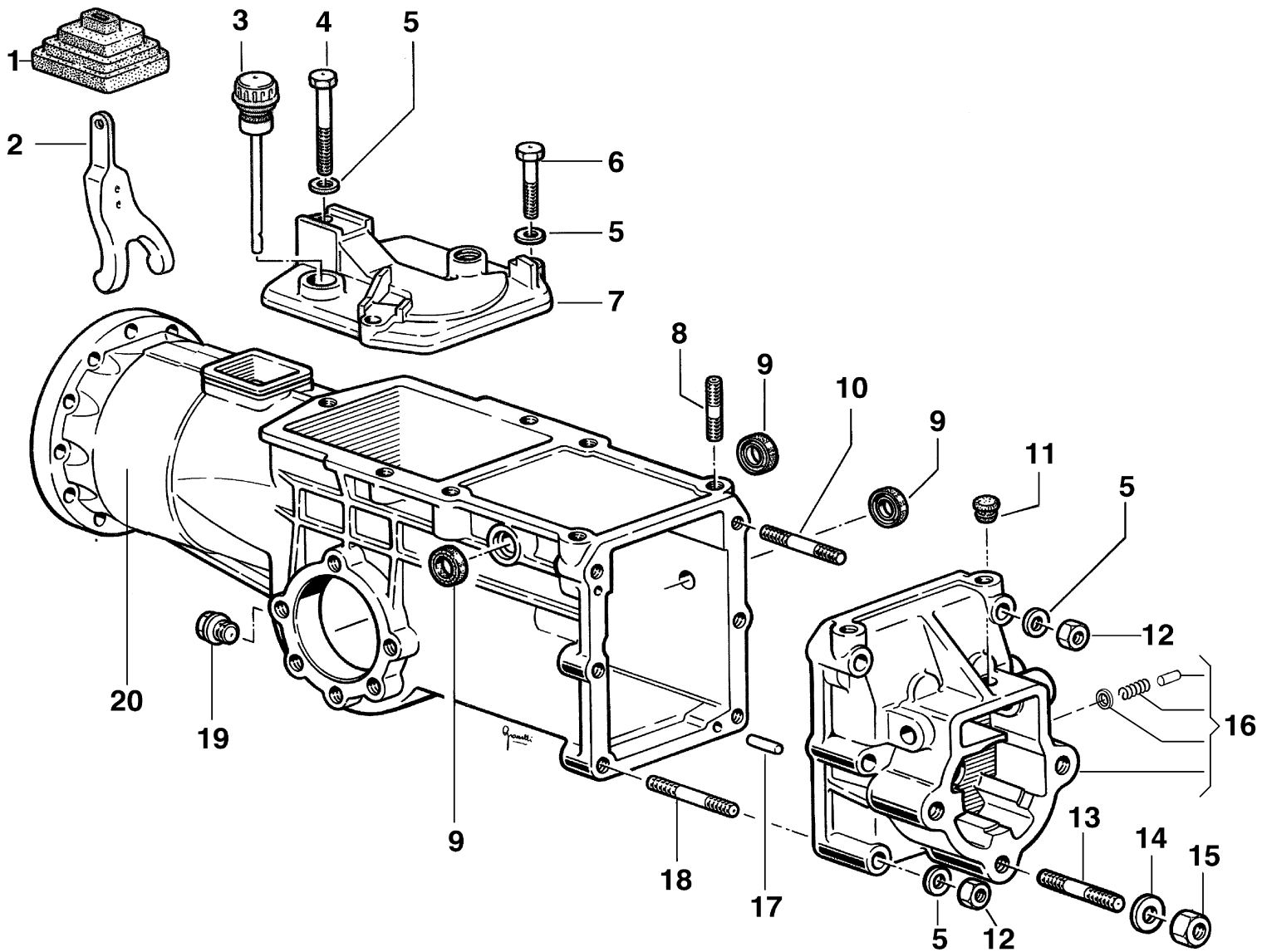

Ref.Nu	Qty	Part number	Description	Validity from	Validity till	Notes	Bulletin
1	1	F0751646	Bellows				
2	1	YF0750011	Lever				
3	1	F1290819	Cap				
4	1	N6294400	Screw				
5	1	YN4365400	Washer				
6	1	3806074R	Screw				
7	1	F1290802	Upper cover				
8	1	N3812500	Stud				
9	1	YN0203000	Ring				
10	1	N3825400	Stud				
11	1	YF0750835	Cap				
12	1	N1458800	Nut				
13	1	N3861500	Stud				
14	1	YN4387700	Washer				
15	1	N1470500	Nut				
16	1	YF1290817	Set cover				
17	1	YN5124300	Pin				
18	1	N3825750	Stud				
19	1	YN5254000	Oil cap				
20	1	68320135	Speed-change gear box				

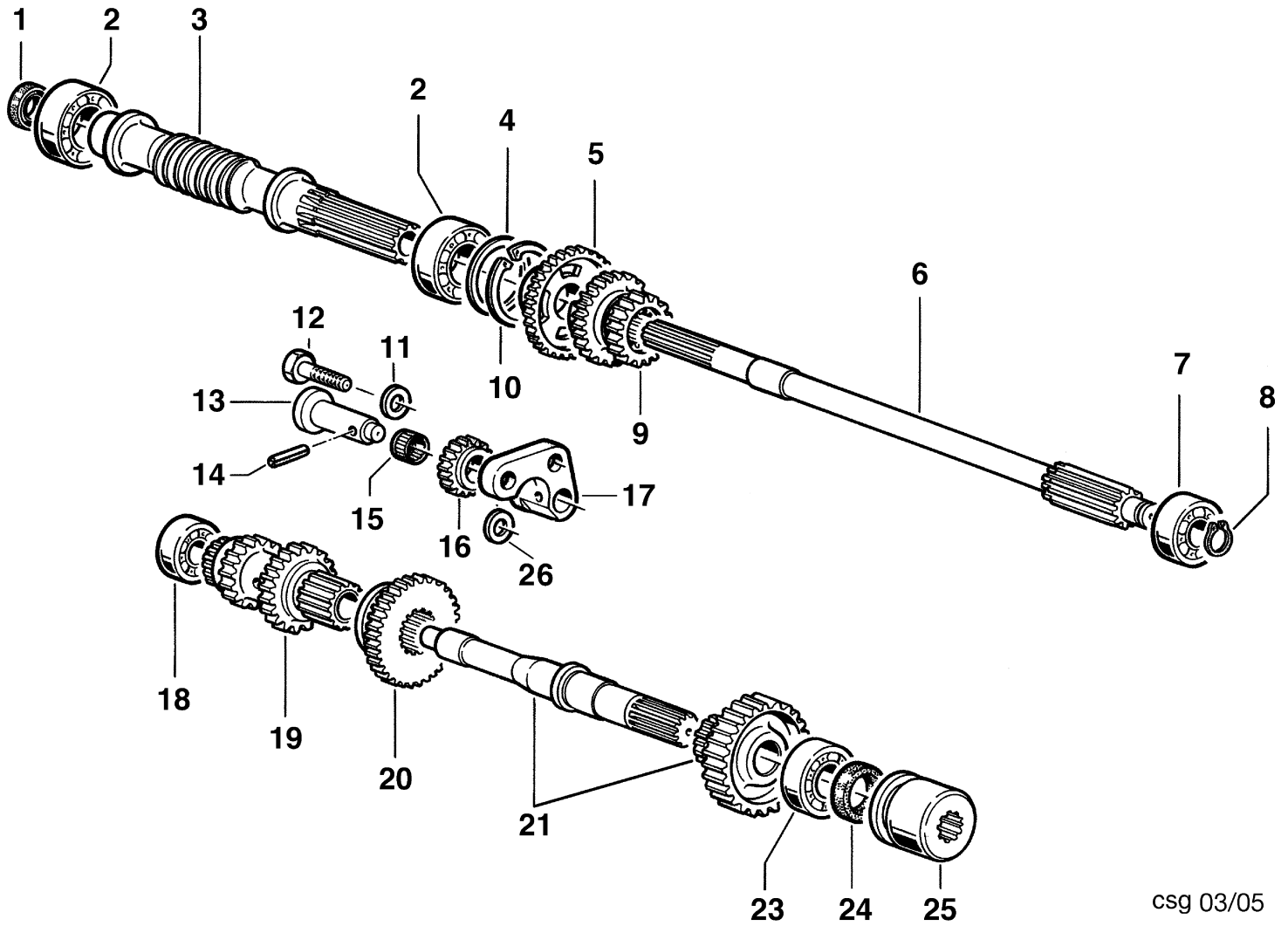

csg 03/05

Ref.Nu	Qty	Part number	Description	Validity from	Validity till	Notes	Bulletin
1	1	N0204750	Gasket				
2	1	N1270751	Bearing				
3	1	F1290800	Shaft				
4	1	N5010200	Washer				
5	1	F1290812	Sprocket				
6	1	F1290811	Shaft				
7	1	N1257700	Bearing				
8	1	3024015	Seeger				
9	1	YF1290813	Gear (Sliding)				
10	1	N0136900	Seeger				
11	1	005000343	Washer				
12	1	N6327500	Screw				
13	1	F1290803	Pin				
14	1	N5115000	Cotter pin				
15	1	3037026R	Roller cage				
16	1	YF1290804	Sprocket				
17	1	F1290807	Support				
18	1	N1251500	Bearing				
19	1	F1290810	Gear				
20	1	YF1290805	Sprocket				
21	1	R1290814	Shaft (Complete)				
23	1	YN1263701	Bearing				
24	1	YN0207300	Ring				
25	1	F1290816	Sleeve				
26	1	N5001900	Washer				

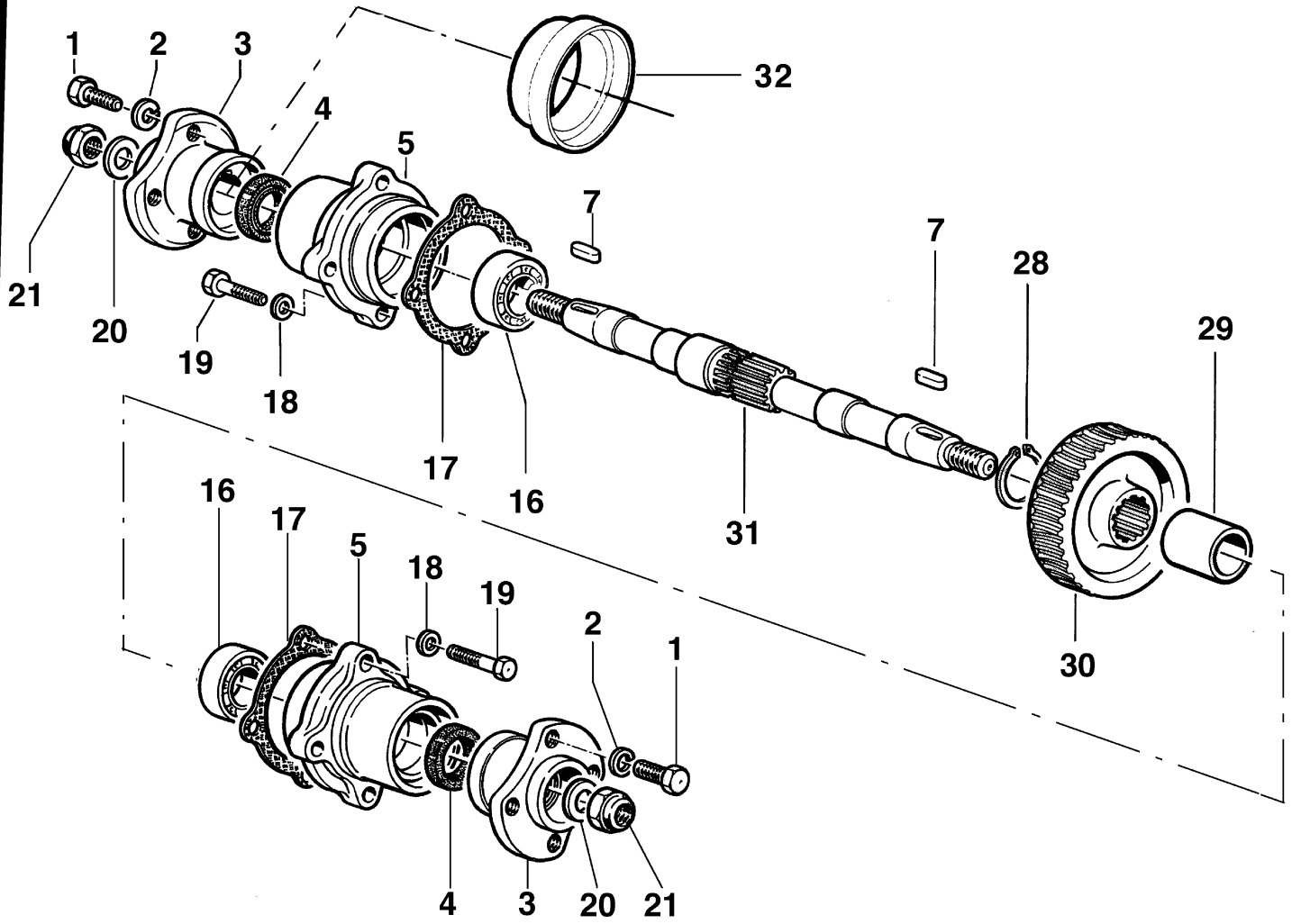

CSG 07/06

Ref.Nu	Qty	Part number	Description	Validity from	Validity till	Notes	Bulletin
1	1	N6322000	Screw				
2	1	3819014R	Grower				
3	1	YF1290211	Wheel hub				
4	1	YN0209720	Ring				
5	1	F1290209	Support				
7	1	YN0646800	Key				
16	1	N1272501	Bearing				
17	1	R1096000	Gasket set				
18	1	YN4365400	Washer				
19	1	3806067R	Screw				
20	1	N4403000	Grower				
21	1	YN1479800	Nut				
28	1	N0124150	Seeger				
29	1	F1290216	Spacer				
30	1	F1290215	Wheel				
31	1	YF1290214	Shaft				
32	1	F1290227	Guard				

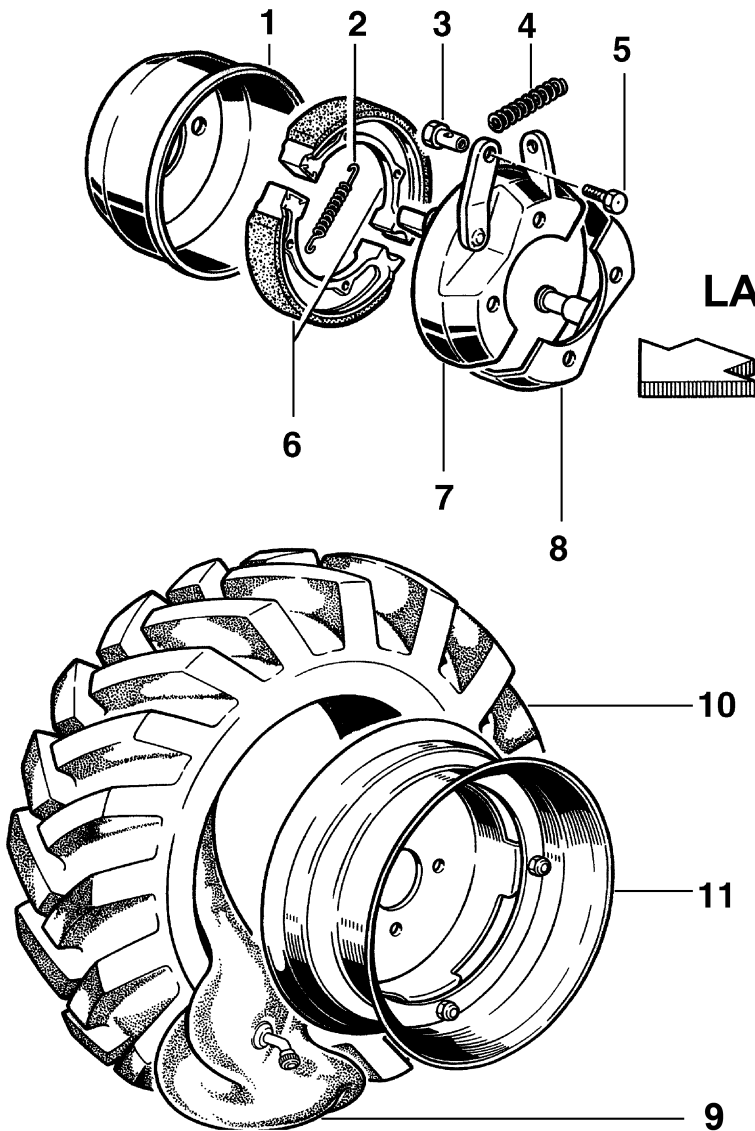

Ref.Nu	Qty	Part number	Description	Validity from	Validity till	Notes	Bulletin
1	1	N2382700	Cable reel				
2	1	YN3105100	Spring				
3	1	YF1290225	Clamp				
4	1	N3101050	Spring				
5	1	301000042	Screw				
6	1	YN2362700	Brake shoe				
7	1	F1290223	Half-cable reel				
8	1	F1290220	Half-cable reel				
9	1	YN4882500	Inner tube			5.00-10	
9	1	N4881500	Inner tube			4.00-10	
10	1	N4853500	Tire			5.00-10	
10	1	N4852000A	Tire			4.00-10	
11	1	69200014	Rim			4.00/5.00-10	

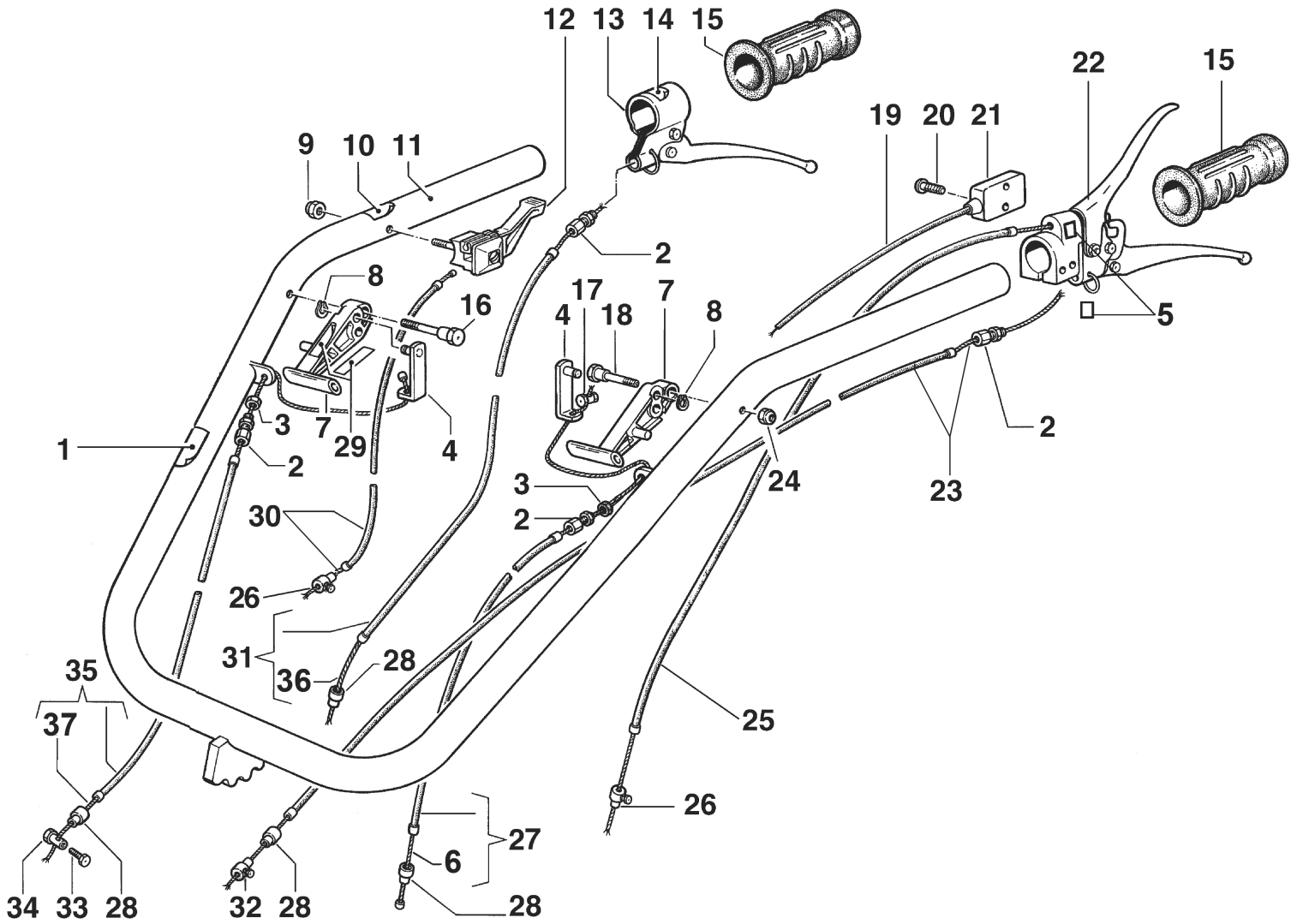

Ref.Nu	Qty	Part number	Description	Validity from	Validity till	Notes	Bulletin
1		-	Not available for this product				
2	1	YN5801000	Adjuster assy				
3	1	3911008R	Nut				
4	1	F1291619	Bracket				
5		-	Not available for this product				
6	1	F1291617	Bushing				
7	1	F1291614	Lever				
8	1	N1734000	Ring				
9	1	3914006R	Nut				
10		-	Not available for this product				
11	1	F1291640	Handle kit				
12	1	YN2803660	Fuel control				
13	1	N2806200	Handle				
14		-	Not available for this product				
15	1	YN2847300	Knob				
16	1	F1291616	Pin				
17	1	N5901500	Clamp				
18	1	F1291615	Pin				
19	1	F1182601	Cable			Motori benzina; Gasoline engines	
20	1	N6182150	Screw			Motori benzina; Gasoline engines	
21	1	N2542360	Switch			Motori benzina; Gasoline engines	
22	1	N2806110	Handle				
23	1	N5488035A	Transmission				BT12-003-11/10
24	1	3914010R	Nut				
25	1	N5476600	Transmission			Motori diesel; Diesel engines	
25	1	N5477050	Transmission			15LD400; Yanmar L70; Yanmar L100	
26	1	F1300004	Clamp			Honda GX270; Vanguard; Kohler CS8.5	
26	1	YN5901000	Clamp				
27	1	N5481100	Transmission				
28	1	N5852100A	Clamp				
29		-	Not available for this product				
30	1	N5464160	Transmission			15LD400; Yanmar L70; Yanmar L100	
30	1	N5467270	Transmission			ALN330; CA340; Honda GX270; Honda GX160; Vanguard; Kohler CS8.5	
30	1	N5467270	Transmission			15LD315; 15LD350; IM350; IM359; ACT280; 6LD400; A349	
31	1	N5491250	Transmission				
32	1	YN5901600	Clamp				
33	1	301000042	Screw				
34	1	YF1290225	Clamp				
35	1	N5483810	Transmission				
36	1	N5485405	Transmission				
37		-	Not available for this product				

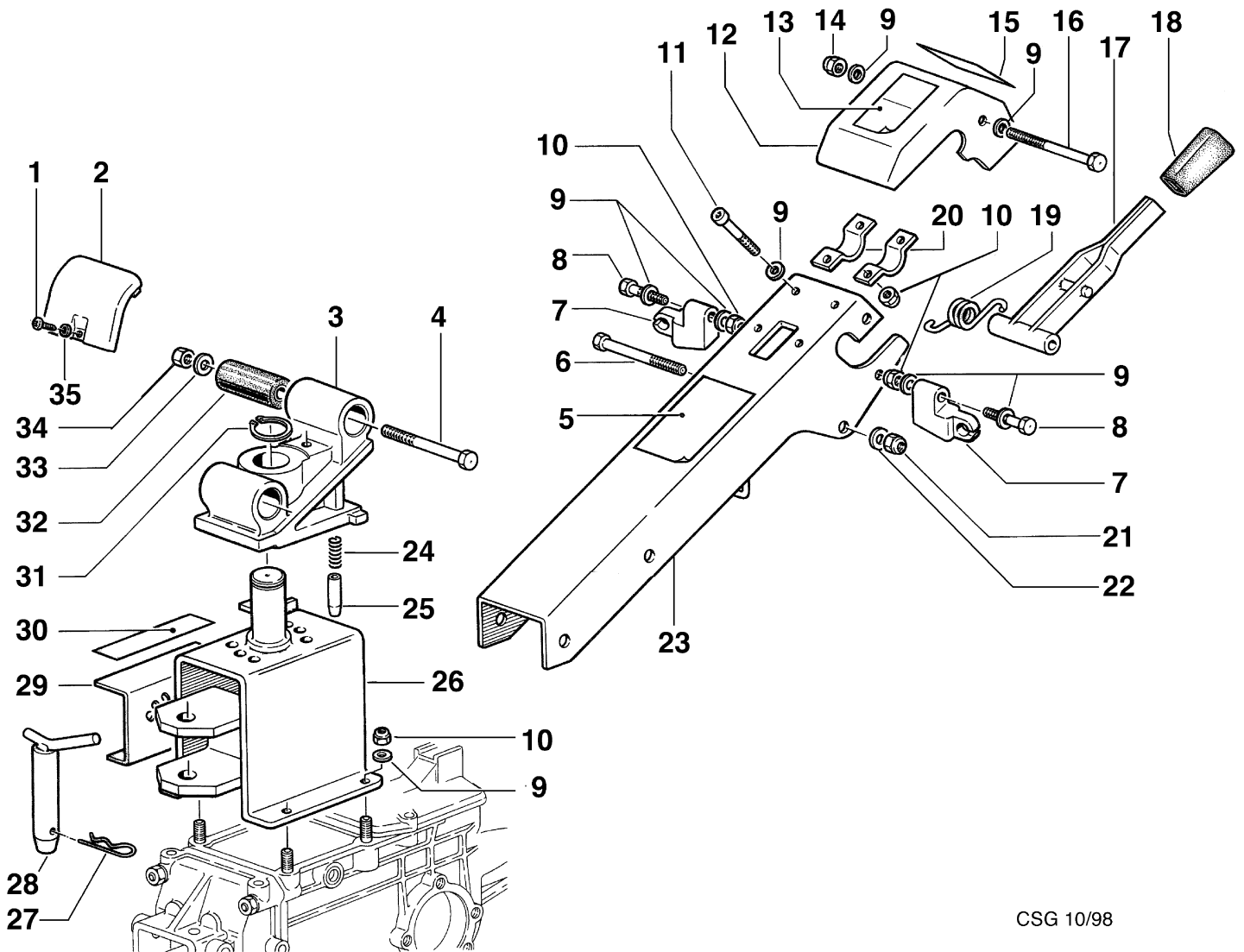

CSG 10/98

Ref.Nu	Qty	Part number	Description	Validity from	Validity till	Notes	Bulletin
1	1	N6192200	Screw				
2	1	F1291651	Cover				
3	1	R0000114	Grip-end				
4	1	N6407550	Screw				
5	-	-	Not available for this product				
6	1	YN6361500	Screw				
7	1	F1255009B	Support				BT12-001-10/09
8	1	3806067R	Screw				
9	1	3916008R	Washer				
10	1	N1458800	Nut				
11	1	N6289250	Screw				
12	1	68240022	Cover				
13	-	-	Not available for this product				
14	1	3914010R	Nut				
15	-	-	Not available for this product				
16	1	N6306500	Screw				
17	1	YF1291636	Lever				
18	1	YN2840480	Knob				
19	1	YF1291634B	Spring				
20	1	YF1151601	Clamp				
21	1	3914014R	Nut				
22	1	3916010R	Washer				
23	1	F1291642	Handlebar rod				
24	1	K3503380	Spring				
25	1	K3502650	Shutter				
26	1	68320010E	Column support				
27	1	N5148800	Cotter pin				
28	1	F0751647	Pin				
29	1	F1291627B	Selector switch				
30	-	-	Not available for this product				
31	1	N0126400	Seeger				
32	1	N4924200	Silent block				
33	1	N4384360	Washer				
34	1	N1470500	Nut				
35	1	3916005R	Sealing washer				

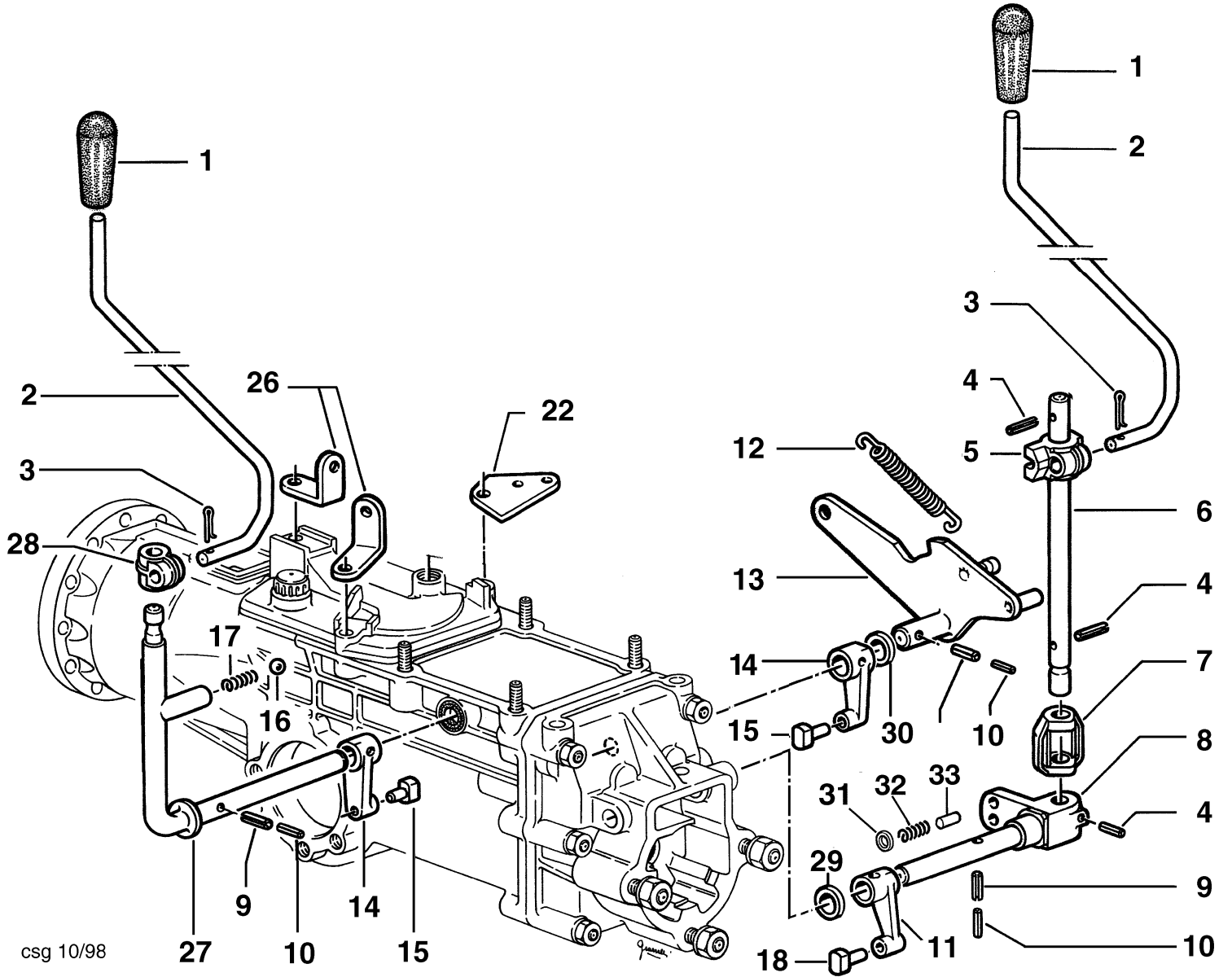

Ref.Nu	Qty	Part number	Description	Validity from	Validity till	Notes	Bulletin
1	1	YN3753600	Knob				
2	1	F1291641	Handlebar				
3	1	YN1054900	Cotter pin				
4	1	N5113800	Pin				
5	1	YF1291633	Support				
6	1	YF1291637	Lever				
7	1	F1241614	Shoe				
8	1	F1291613	Pin				
9	1	YN5125500	Pin				
10	1	YN5109300	Pin				
11	1	F1051700	Lever				
12	1	YN3118060	Spring				
13	1	F1291612	Cam				
14	1	F1291603	Lever				
15	1	YF1291604	Sliding block				
16	1	YN4745400	Ball				
17	1	YN3104250	Spring				
18	1	F1050831	Sliding block				
22	1	F1291607	Plate				
26	1	F1291605	Bracket				
27	1	F1291632	Lever				
28	1	YF1061633	Fix plate (Handlebar)				
29	1	N4394700	Washer				
30	1	K8491008	Washer				
31	1	N0281400	Ring				
32	1	N3101020	Spring				
33	1	F1291661	Cap				

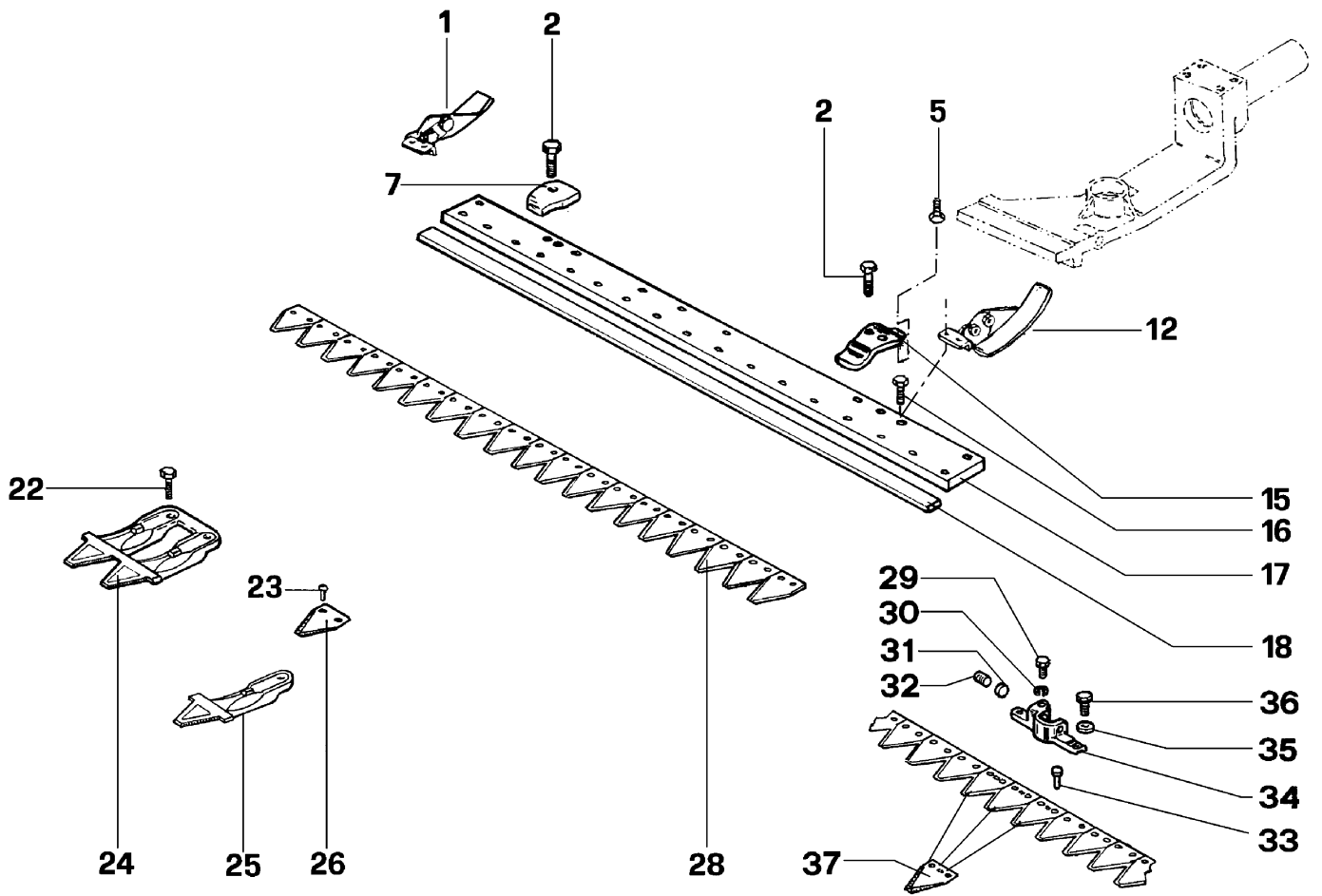

barra speciale attacco registrabile

Ref.Nu	Qty	Part number	Description	Validity from	Validity till	Notes	Bulletin
1	1	F1303153	Sliding block	10/2000			
2	1	YN6332800	Screw				
5	1	N6245800	Screw				
7	1	F0582687	Plate				
12	1	F1303153	Sliding block	10/2000			
15	1	F1113112	Press blade (Long)				
16	1	N6321250	Screw	10/2000			
17	1	F1303118	Plate			1270 mm	
17	1	F1303119	Plate			1400 mm	
17	1	F1303116	Plate			950 mm	
17	1	F1303117	Plate			1150 mm	
18	1	F0712031	Slide			1150 mm	
18	1	F1073220	Slide			1400 mm	
18	1	F0591593	Slide			1270 mm	
18	1	F0712027	Slide			950 mm	
22	1	N6322000	Screw				
23	1	YN0886600	Rivet				
24	1	F1113114	Tooth (Double)				
25	1	F1113114	Tooth (Double)				
26	1	F1073216R	Blade				
28	1	F1073349	Blade			950 mm SP	
28	1	F1073388	Blade			1400 mm SP	
28	1	F1073276	Blade			1150 mm SP	
28	1	F1073277	Blade			1270 mm SP	
29	1	YN6262200	Screw				
30	1	3819013R	Grower				
31	1	YF1073364	Valve				
32	1	N6433900	Screw				
33	1	F1073261	Rivet				
34	1	F1073363B	Clutch driver			Per barra SP; For SP bar	
35	1	3819013R	Grower				
36	1	3806063	Screw				
37	1	F1073273	Blade				

esm universal 102/122/142 clip clap
L635.00 L637.00 L639.00

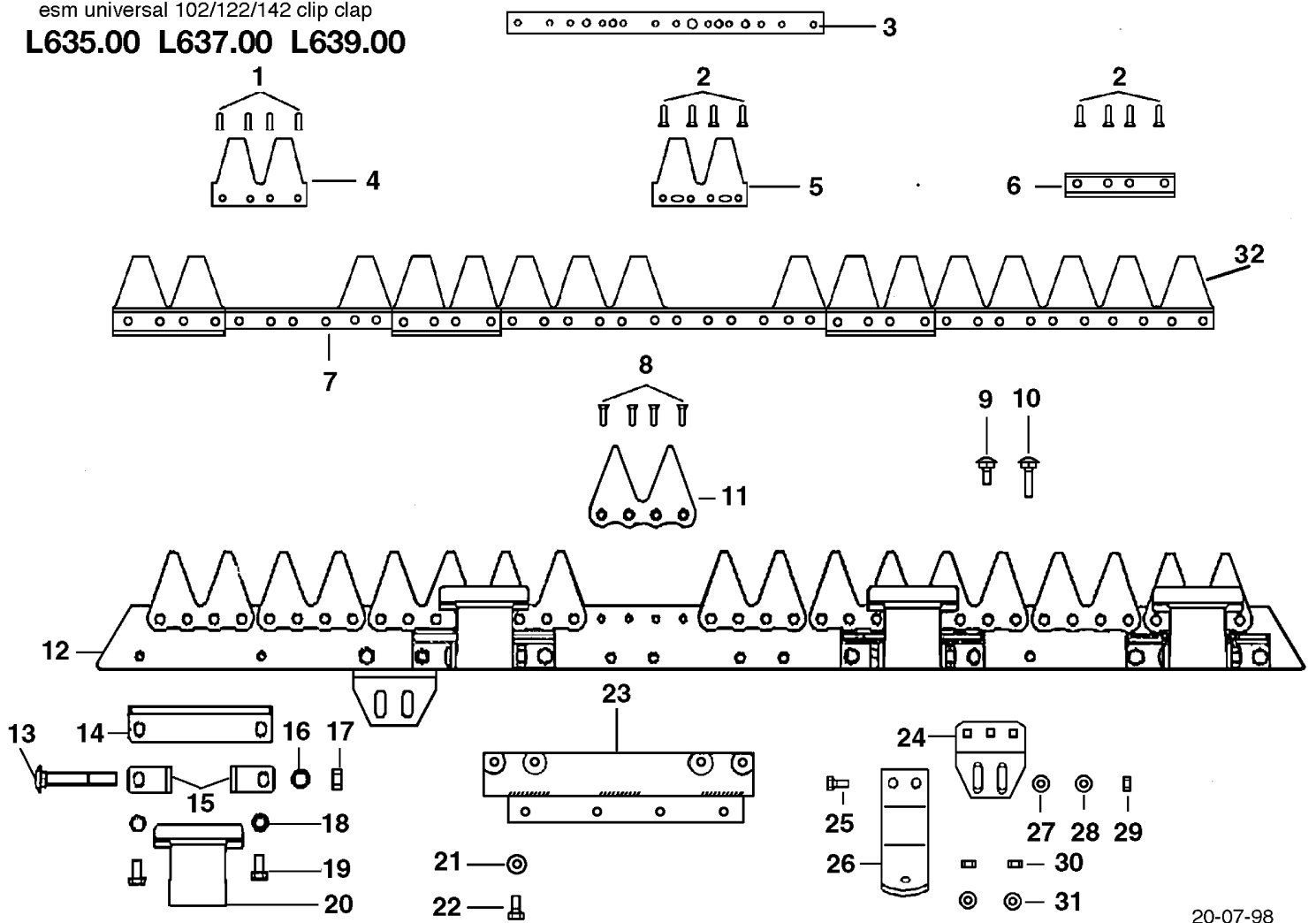

20-07-98

Ref.Nu	Qty	Part number	Description	Validity from	Validity till	Notes	Bulletin
1	1	R1504705	Rivet				
2	1	R1504706	Rivet				
3	1	F1073501	Plate				
4	1	F1073451	Shear blade (Double)				
5	1	F1073452	Shear blade (Double)				
6	1	F1073453	Slide				
7	1	F1073504	Back (Blade)			142 cm	
7	1	F1073502	Back (Blade)			102 cm	
7	1	F1073468	Shear blade			122 cm	
8	1	N0892500	Rivet				
9	-	-	Not available for this product				
10	-	-	Not available for this product				
11	1	F1073456	Tooth (Double)				
12	1	F1073506	Back (Bar)			122 cm	
12	1	F1073507	Back (Bar)			142 cm	
12	1	F1073505	Back (Bar)			102 cm	
13	1	F1073462	Screw				
14	1	F1073458	Plate				
15	1	F1073459	Bracket				
16	-	-	Not available for this product				
17	1	N1464800	Nut				
18	-	-	Not available for this product				
19	1	3806063	Screw				
20	1	F1073457	Pusher				
21	1	YN4365400	Washer				
22	1	YN6254600	Screw				
23	1	F1073401	Connection plate				
24	1	F1073430	Attachment (Sole)				
25	1	3806067R	Screw				
26	1	F1073428	Sole				
27	1	3916008R	Washer				
28	1	YN4365400	Washer				
29	1	R1504723	Nut				
30	-	-	Not available for this product				
31	-	-	Not available for this product				
32	1	F1073467	Shear blade			102 cm	
32	1	F1073468	Shear blade			122 cm	
32	1	F1073469	Shear blade			142 cm	

esm comunale 122/142

L641.00 L643.00

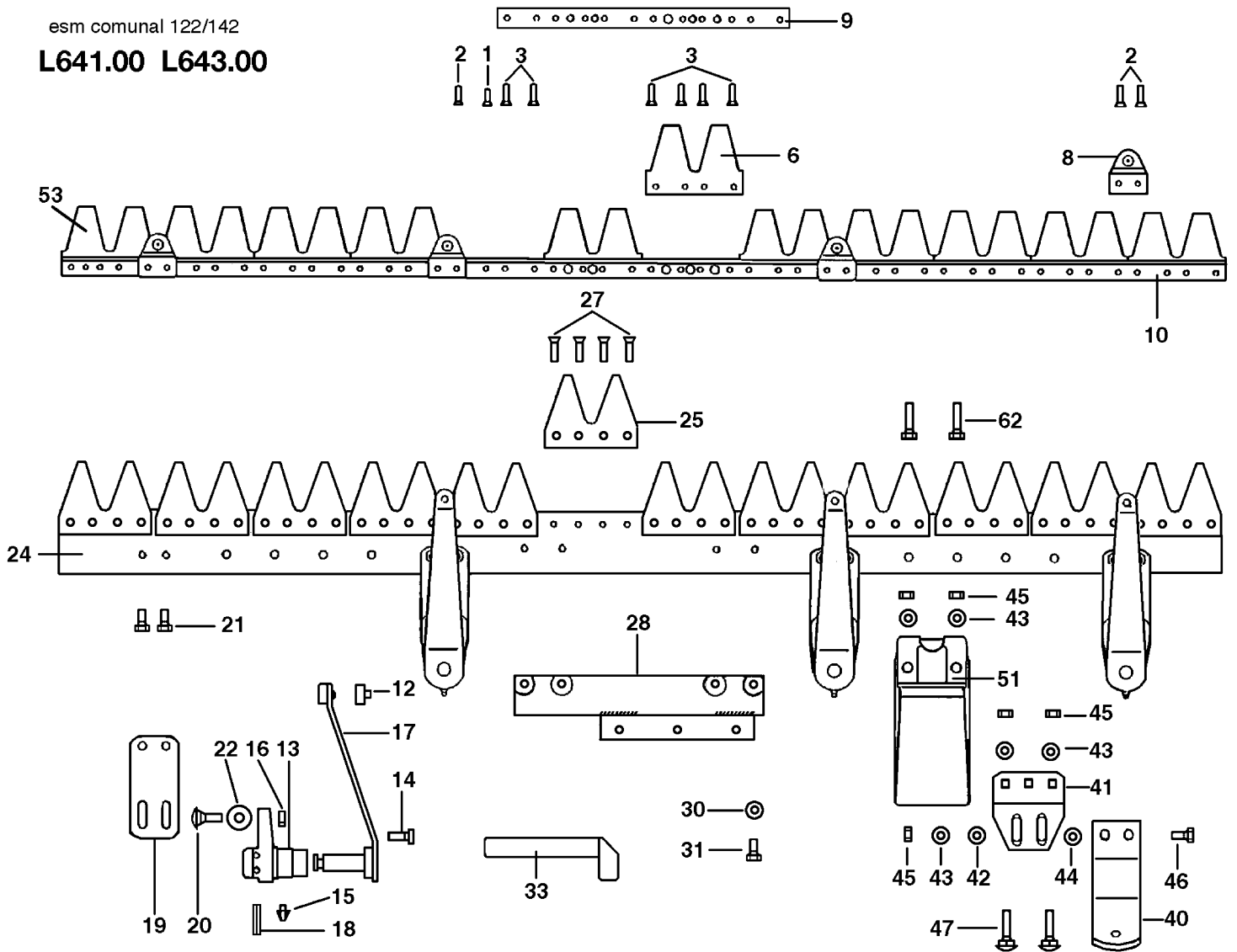

Ref.Nu	Qty	Part number	Description	Validity from	Validity till	Notes	Bulletin
1	1	R1504705	Rivet				
2	1	R1504706	Rivet				
3	1	F1073441	Rivet				
6	1	R1504709	Shear blade (Double)				
8	1	R1504764	Support				
9	1	F1073438	Plate				
10		-	Not available for this product				
12	1	R1504773	Bushing				
13	1	R1504768	Support				
14	1	R1504769	Screw				
15	1	R1504770	Nipple				
16	1	R1504723	Nut				
17	1	R1504772	Swing arm				
18	1	R1504771	Pin				
19	1	F1073436	Plate				
20	1	F1073442	Screw				
21	1	N6249300	Screw				
22	1	R1504776	Washer				
24	1	F1073418	Back (Bar)			142 cm	
24	1	F1073417	Back (Bar)			122 cm	
25	1	F1073422	Tooth (Double)				
27	1	N0892500	Rivet				
28	1	F1073401	Connection plate				
30	1	YN4365400	Washer				
31	1	YN6254600	Screw				
33	1	F1073415	Lever (Fitting)				
40	1	F1073428	Sole				
41	1	F1073430	Attachment (Sole)				
42	1	3916008R	Washer				
43	1	YN4365400	Washer				
44	1	F1073443	Washer				
45	1	R1504723	Nut				
46	1	3806067R	Screw				
47	1	R1504720	Screw				
51	1	F1073432	Slide shoe				
52	1	3806070R	Screw				
53	1	F1073410	Shear blade			142 cm	
53	1	F1073409	Shear blade			122 cm	

L1019.00

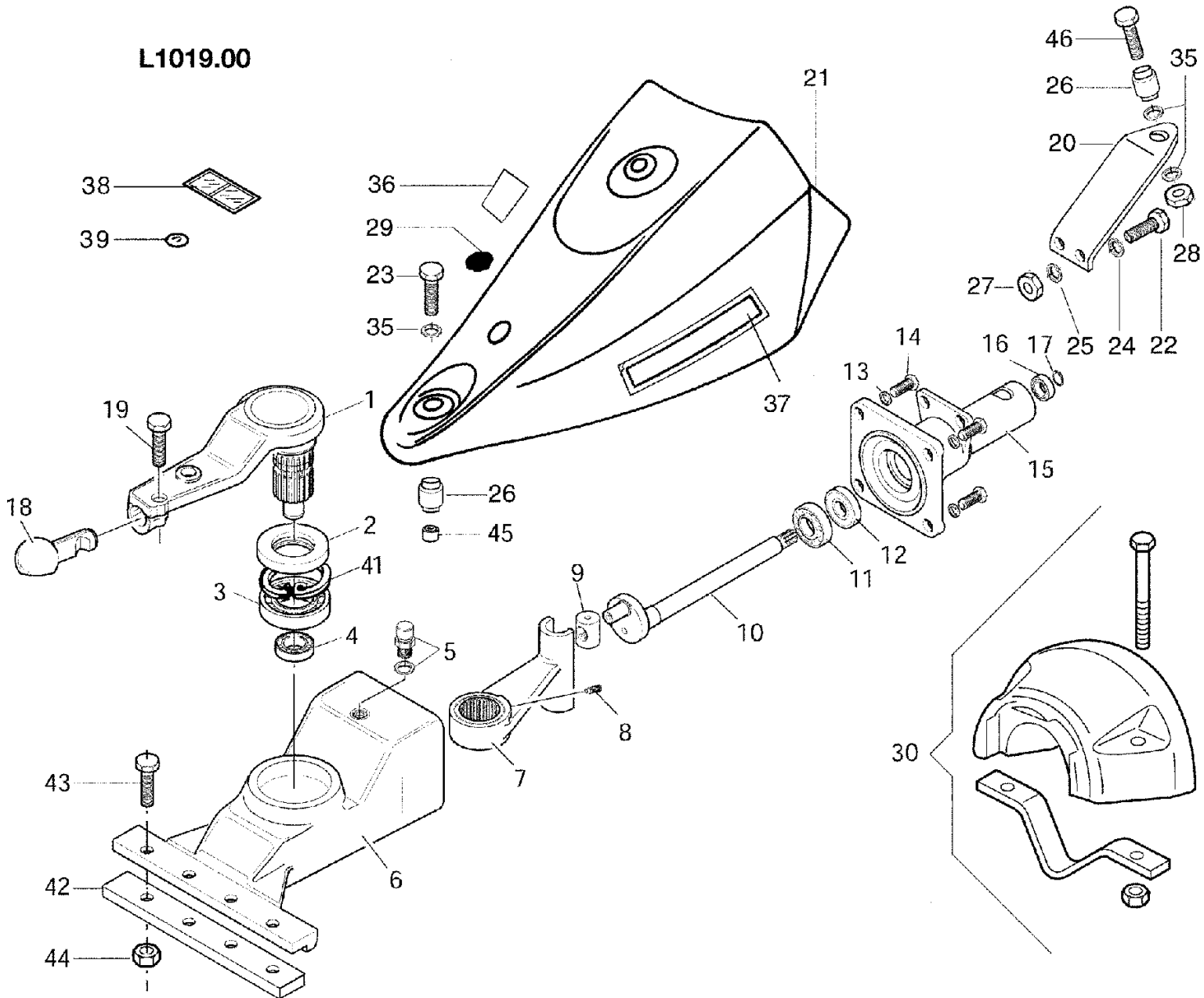

Ref.Nu	Qty	Part number	Description	Validity from	Validity till	Notes	Bulletin
1	1	F1303156	Connecting rod				
2	1	YN0222805	Ring				
3	1	N1289200	Bearing				
4	1	YN1263701	Bearing				
5	1	K4101420	Cap				
6	1	F1303100	Housing				
7	1	F1303102	Connecting rod				
8	1	N6251000	Screw				
9	1	F1303106	Switch				
10	1	F1303108	Shaft				
11	1	N1272501	Bearing				
12	1	N0210045	Ring				
13	1	3819014R	Grower				
14	1	3806094R	Screw				
15	1	F1303101	Cover				
16	1	YN1263201	Bearing				
17	1	3024020R	Seeger				
18	1	F1303155	Pin				
19	1	3806094R	Screw				
20	1	F1303125	Support				
21	1	PA001254	Hood				
22	1	3806067R	Screw				
23	1	YN6402600	Screw				
24	1	3819013R	Grower				
25	1	3916008R	Washer				
26	1	N4924000	Silent block				
27	1	320000028R	Nut				
28	1	YN1470200	Nut				
29	1	N5265900	Cap				
30	1	L0105700	Set (Counterweight) Oil bath movement				
35	1	3916012	Washer				
36	-	-	Not available for this product				
37	-	-	Not available for this product				
38	-	-	Not available for this product				
39	-	-	Not available for this product				
41	1	N0140800	Seeger				
42	1	L0081100	Washer				
43	1	YN6332800	Screw				
44	1	YN1463650	Nut				
45	1	F1303133	Spacer				
46	1	N6399710	Screw				

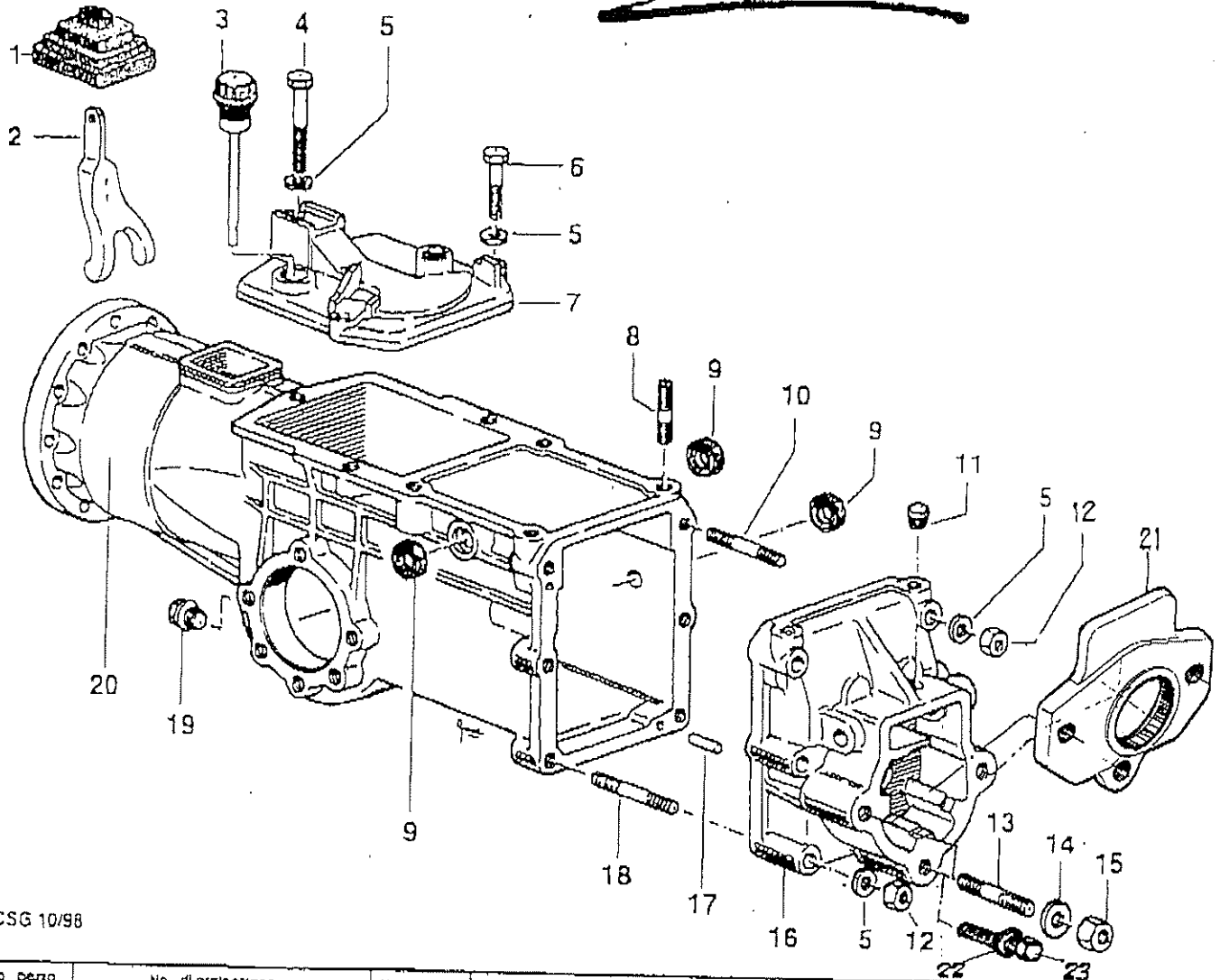

CSG 10/98

No. pezzo No. nimm No. pièce No. END No. pieza	No. di ordinazione Part No. No. de commande Bestell - Nr. No. de pedido	No. pezzo No. piece No. pièce No. END No. pieza	No. di ordinazione Part No. No. de commande Bestell - Nr. No. de pedido	No. pezzo No. piece No. pièce No. END No. pieza	No. di ordinazione Part No. No. de commande Bestell - Nr. No. de pedido
1	F75.1646	17	N5.1243.00 6x20mm		
2	F75.0011	18	N3.8257.00		
3	F129.0819	19	N5.2540.00		
4	N6.2944.00	20	F129.0801		
5	N4.3654.00	21	F129.0820		
6	N6.2741.00	* 13	N3.8662.00 3866200		
7	F129.0818 (411)	22	N4.3843.60		
	F129.0802 (410)	23	N6.3879.50		
8	N3.8125.00				
9	N2030.00 14x22x4				
10	N3.8245.00				
11	F75.0835				
12	N1.4585.00				
* 13	N3.8615.00 19/2x30				
14	N4.3877.00 K 430.2510				
15	N1.4705.00				
16	F129.0817				

HAFOG
 Salg. Service . Fabrilation . Import
 Lyngager 5-9 2805 Brandby
 Telefon 43 98 66 11 . Fax 43 28 66 25

Segnalazioni di validità
 Usage code
 Signalements de validité
 Gültigkeitsvermerk
 Indicación de validez

FICHES

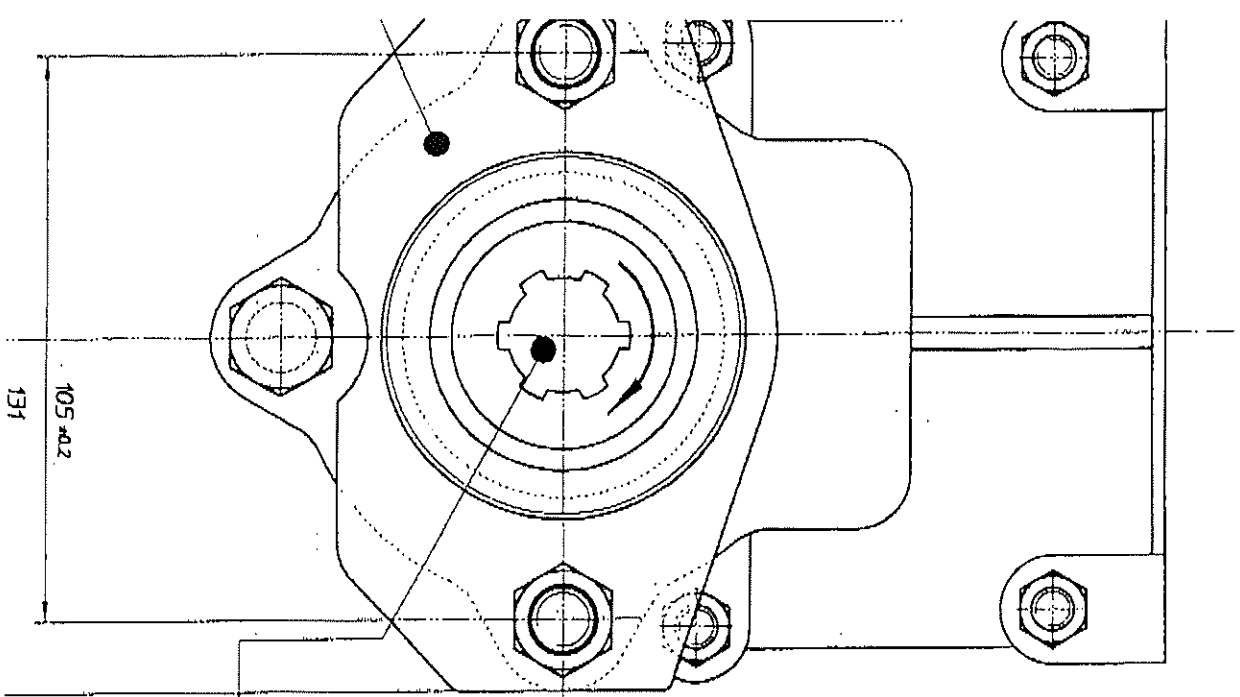

Scanalato UN221

Centro ruota

12.5

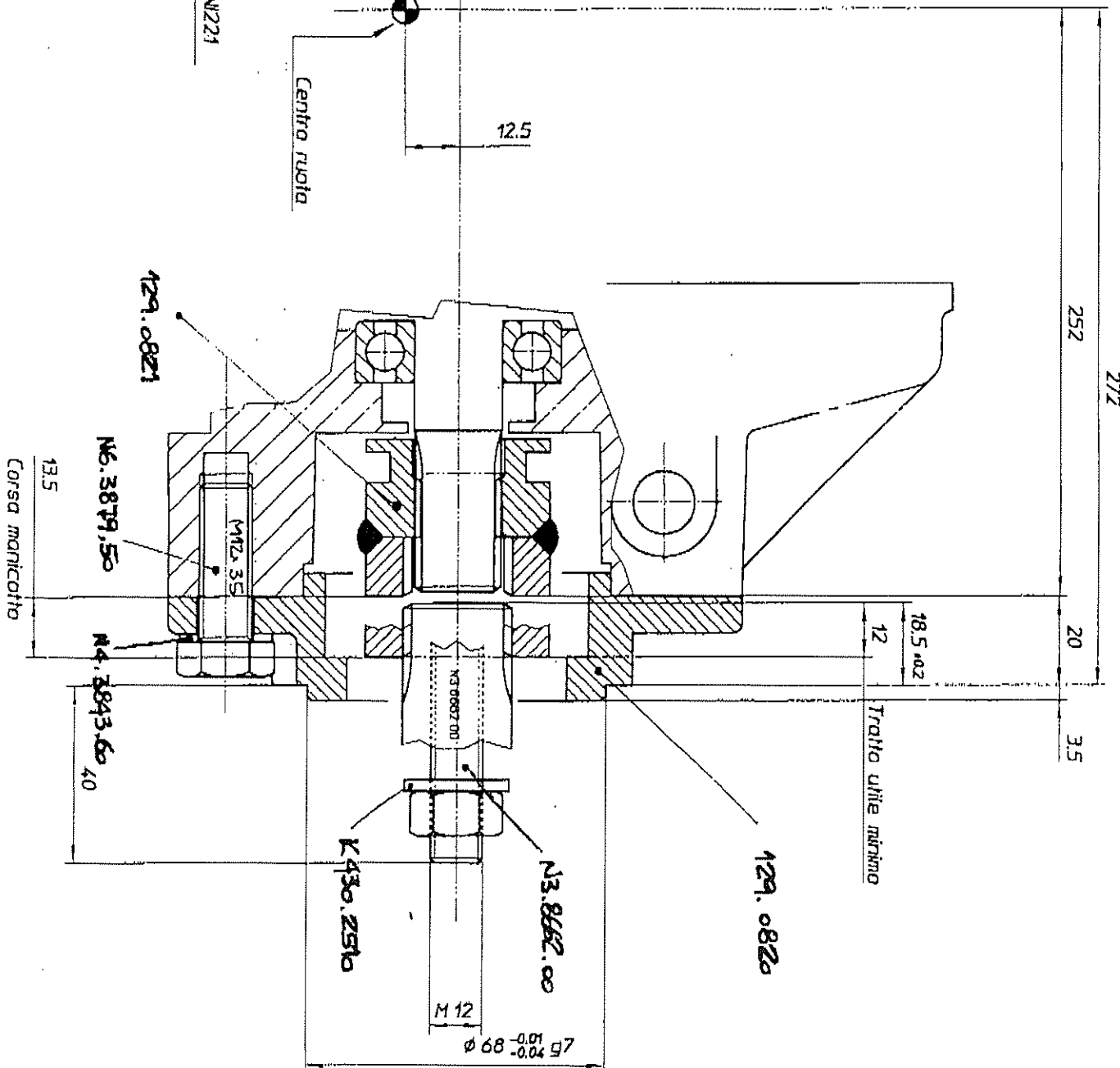

272

252

20

3.5

18.5 ± 0.2

Traito utile minimo

12

N29.0821

N6.3879.50

M12.35

N4.3893.60

Corsa manicotto

13.5

K430.2510

N3.8662.00

N29.0820

M 12

68 ± 0.02

69219013 - 69219008 - 69219012

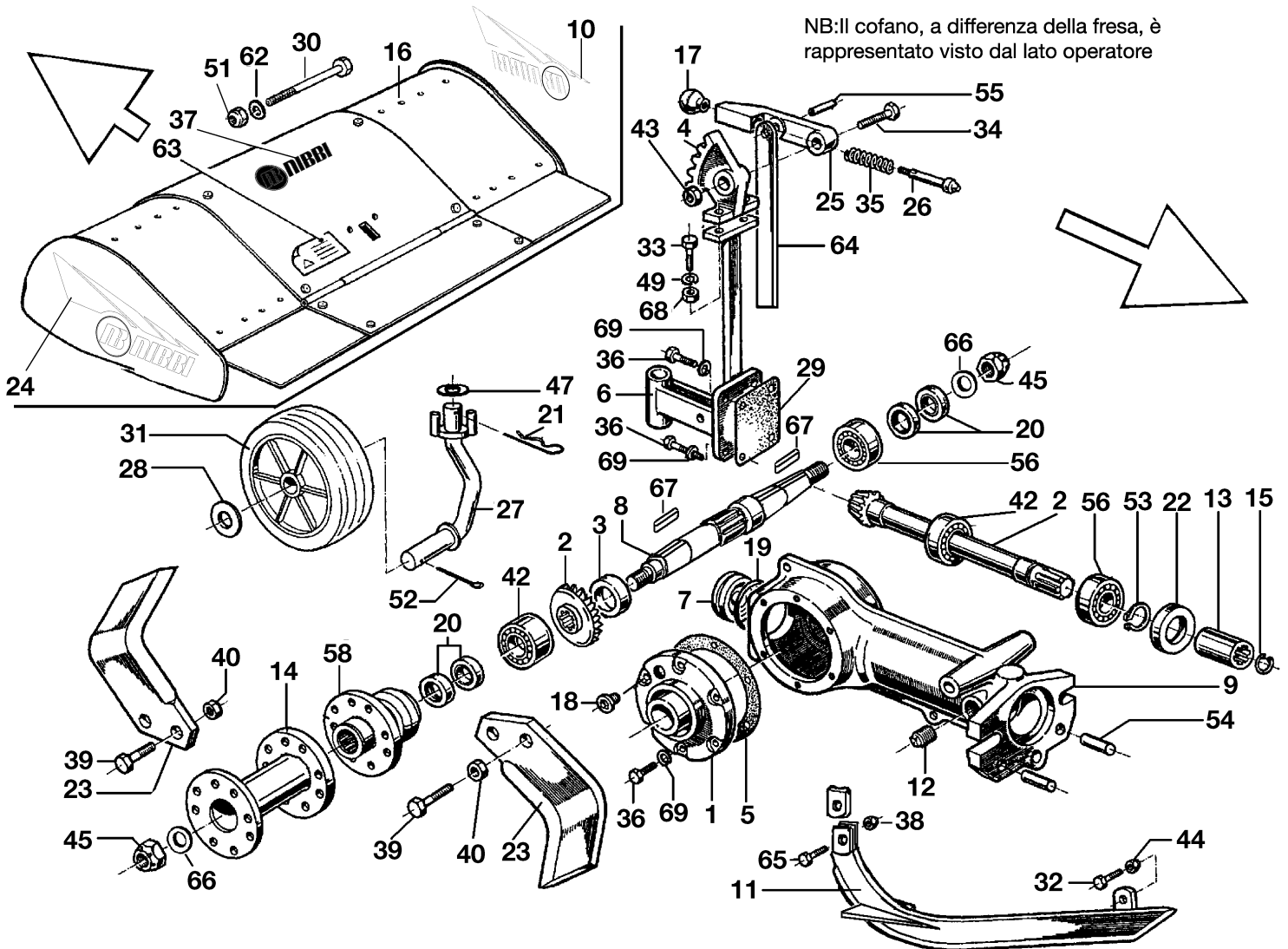

Ref.Nu	Qty	Part number	Description	Validity from	Validity till	Notes	Bulletin
1	1	K1101060	Cover				
2	1	K4806930	Set bevel gear				
3	1	K4801310	Spacer				
4	1	K4302350	Sector				
5	1	K1101100	Gasket				
6	1	K4808008	Support (Wheel)				
7	1	K4302520	Cap				
8	1	K4808060	Shaft				
9	1	K1101070	Arm				
10	1	68330029	Mark			Su richiesta; Upon request; DX; RIGHT	
11	1	F0015613	Cutter tool				
12	1	K8535002	Cap				
13	1	K1101080	Joint				
14	1	69210038	Spacer				BT12-002- 11/10
15	1	028200019	Ring				
16	1	PA001873	Hood			60+40 cm; Rosso; Red	
16	1	PA001872	Hood			70+60 cm; Rosso; Red	
16	1	PA001860	Hood			80+60 cm; Rosso; Red	
17	1	K8211001	Knob				
18	1	K8536002	Cap				
19	1	K7035045	O-ring				
20	1	N0209200	Ring				
21	1	N1054500	Cotter pin				
22	1	N0210045	Ring				
23	1	R0000138	Cutters kit			Per fresa 70 cm, kit composto da: F0015602, DX, 10pz + F0015603, SX, 10pz; For tiller 70 cm, set composed by: F0015602, RIGHT, 10pcs + F0015603, LEFT, 10pcs	
24	1	68330030	Mark			Su richiesta; Upon request; SX; LEFT	
25	1	K22035508	Lever				
26	1	K2203560	Piston pin				
27	1	K3501830	Support				
28	1	3916020	Washer				
29	1	K1101230	Gasket				
30	1	N6417235	Screw				
31	1	K1102480	Wheel				
32	1	3806067R	Screw				
33	1	YN6335900	Screw				
34	1	N6399710	Screw				
35	1	K7903026	Spring				
36	1	N6254500	Screw				
37	1	68610007	Mark			Su richiesta; Upon request	
38	1	N1458800	Nut				
39	1	N6262100	Screw				
39	1	N6274000	Screw				
40	1	N1463500	Nut	06/2009			
42	1	N1270751	Bearing				
43	1	K7272009	Nut				
44	1	K7275003	Nut				
45	1	N1482500	Nut			DX; RIGHT	
45	1	N1482600	Nut			SX; LEFT	
47	1	3916020	Washer				
49	1	3819014R	Grower				
51	1	YN1470200	Nut				
52	1	YN1060200	Cotter pin				
53	1	YN0118500	Seeger				
54	1	K8504014	Pin				
55	1	K8503039	Pin				
56	1	YN1270701	Bearing				
58	1	K4808050	Support				
62	1	3916012	Washer				
63	1	F0015577	Mark (Danger)			Su richiesta; Upon request	
64	1	F0015612	Rod				
65	1	3806065	Screw				

66	1	N4418000	Washer
67	1	YN0652200	Key
68	1	N1464600	Nut
69	1	N4364350	Washer

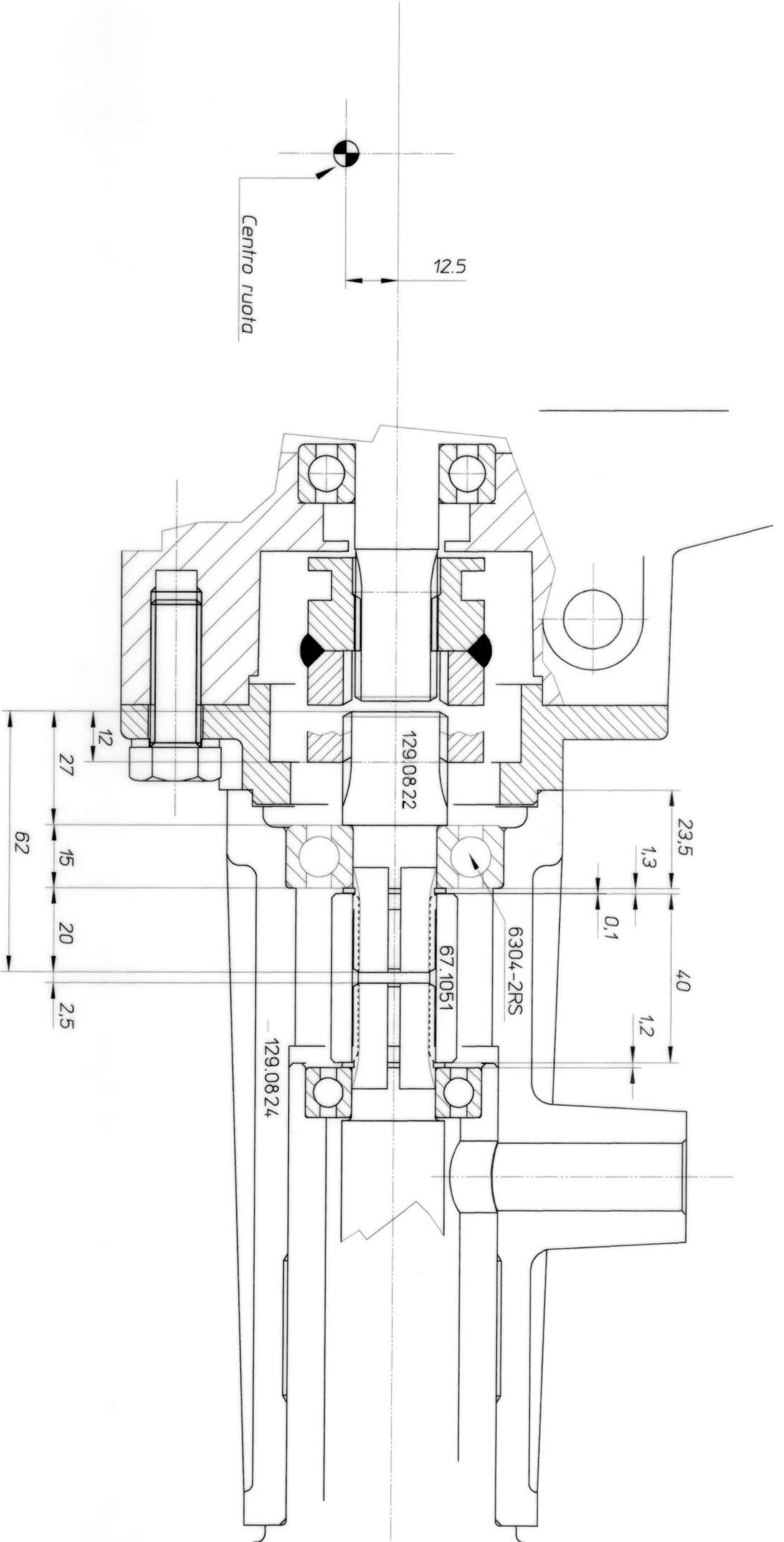

Imodi		Data		Oggetto modifica		Firma		Controllo	
● CARATTERISTICA CRITICA		● CARATTERISTICA IMPORTANTE		NESSUN SIMBOLO		● CARATTERISTICA NORMALE			
Materiale:	UNI:	Tolleranze generali	Grezzi	Lungh. e diametri $\pm 0.5\%$ max $\pm 1\text{mm}$	Spess. 10% con minimo di 1mm	Angoli $\pm 2^\circ$	Lavorati	Lungh. e diam. fino a 18 ± 0.15	da 18 a 80 ± 0.25 , > 80 ± 0.40
Stato:	UNI:	Denominazione:							
Tratt. Term.:	UNI:	Appl. flang. MAK6/7 SU KAM4/5 per MBO							
Tratt. prof. superf.:	UNI:	Gruppo:	Macchina:						
Resistenza (kg/mm ²):	UNI:	Durezza HRC: \pm							
Logo: YARBE		REGGIO EMILIA		ITALY		Disegno N°:		129.00000.00	
						Scala: 1:1		Disegnato da: Gazzotti F.	
						N° pezzi:		Controllato da:	
						Data: 06/07/00			