

FRESA INTERRASASSI

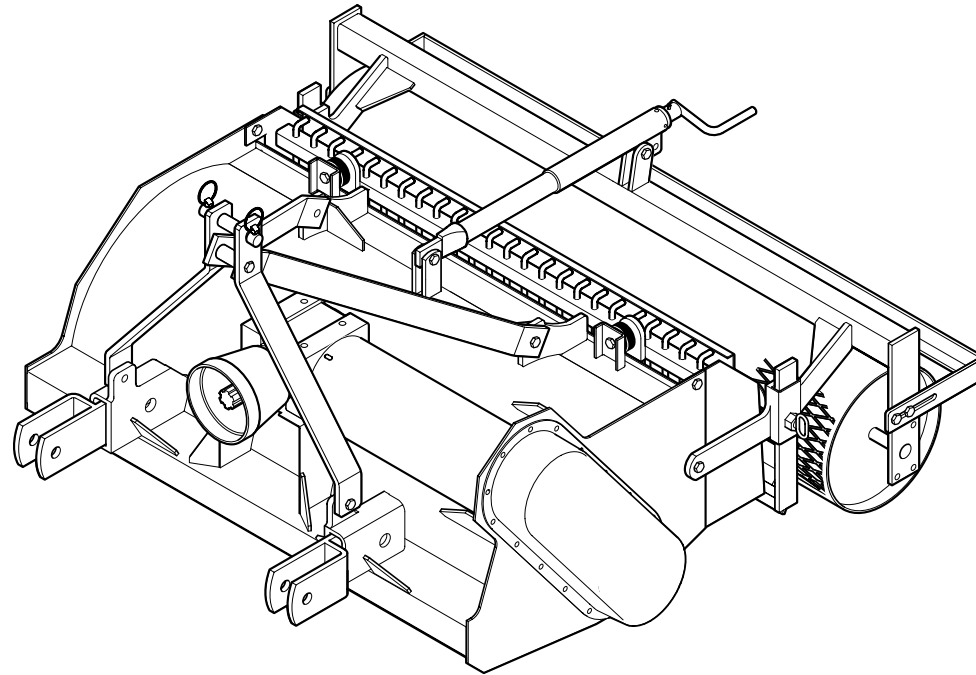

TST-100
TST-113
TST-130
TST-100H
TST-113H
TST-130H



R2 s.a.s. di Rinaldi Roberto & C.

40060 Toscanella di Dozza (Bologna) Italy - Via Valsellustra, 25-29

Tel. +39.0542.672100 • Fax +39.0542.674391

CATALOGO PARTI DI RICAMBIO

SPARE PARTS CATALOGUE
CATALOGUE DE PIECES DETACHEES
ERSATZTEILKATALOG
CATALOGO DE PIEZAS DE REPUESTO

Cod. **060** rev.2

Edizione 05/2008

INDICE DELLE TAVOLE • TABLE INDEX • INDEX DES TABLEUX

01.0	MONTAGGIO RULLO POSTERIORE E GRIGLIA (TST 100)	REAR ROLLER AND GRATE ASSEMBLY (TST 100)	MONTAGE ROULEAUX ARRIERE ET GRILLAGE (TST 100)
02.0	MONTAGGIO RULLO POSTERIORE E GRIGLIA (TST 113)	REAR ROLLER AND GRATE ASSEMBLY (TST 113)	MONTAGE ROULEAUX ARRIERE ET GRILLAGE (TST 113)
03.0	MONTAGGIO RULLO POSTERIORE E GRIGLIA (TST 130)	REAR ROLLER AND GRATE ASSEMBLY (TST 130)	MONTAGE ROULEAUX ARRIERE ET GRILLAGE (TST 130)
04.0	TRASMISSIONE (TST 100)	TRANSMISSION (TST 100)	TRANSMISSION (TST 100)
05.0	TRASMISSIONE (TST 113)	TRANSMISSION (TST 113)	TRANSMISSION (TST 113)
06.0	TRASMISSIONE (TST 130)	TRANSMISSION (TST 130)	TRANSMISSION (TST 130)
07.0	TELAIO - CARTER E ACCESSORI (TST 100-113-130)	FRAME - COVERS AND ACCESSORIES (TST 100-113-130)	CHASSIS - CARTERS ET ACCESSOIRES (TST 100-113-130)
08.0	TRASMISSIONE IDRAULICA (TST 100H)	HYDRAULIC TRANSMISSION (TST 100H)	TRANSMISSION HYDRAULIQUE (TST 100H)
09.0	TRASMISSIONE IDRAULICA (TST 113H)	HYDRAULIC TRANSMISSION (TST 113H)	TRANSMISSION HYDRAULIQUE (TST 113H)
10.0	TRASMISSIONE IDRAULICA (TST 130H)	HYDRAULIC TRANSMISSION (TST 130H)	TRANSMISSION HYDRAULIQUE (TST 130H)
11.0	CASSONETTO SEMINATRICE (SMT 100-113-130)	SEEDER BOX (SMT 100-113-130)	CAISSON SEMOIR (SMT 100-113-130)
12.0	MONTAGGIO RULLO POSTERIORE (SMT 100-113-130)	REAR ROLLER ASSEMBLY (SMT 100-113-130)	MONTAGE ROULEAUX ARRIERE (SMT 100-113-130)
13.0	COMANDI OPERATORE	OPERATION CONTROLS	COMMANDES OPERATEUR



MONTAGGIO RULLO POSTERIORE E GRIGLIA
REAR ROLLER AND GRATE ASSEMBLY
MONTAGE ROULEAUX ARRIERE ET GRILLAGE
MONTAGE HINTERE ROLLEN UND GITTERROST
MONTAGE RODILLOS TRASERO Y ENREJADO

Tav. 01.0

TST-100

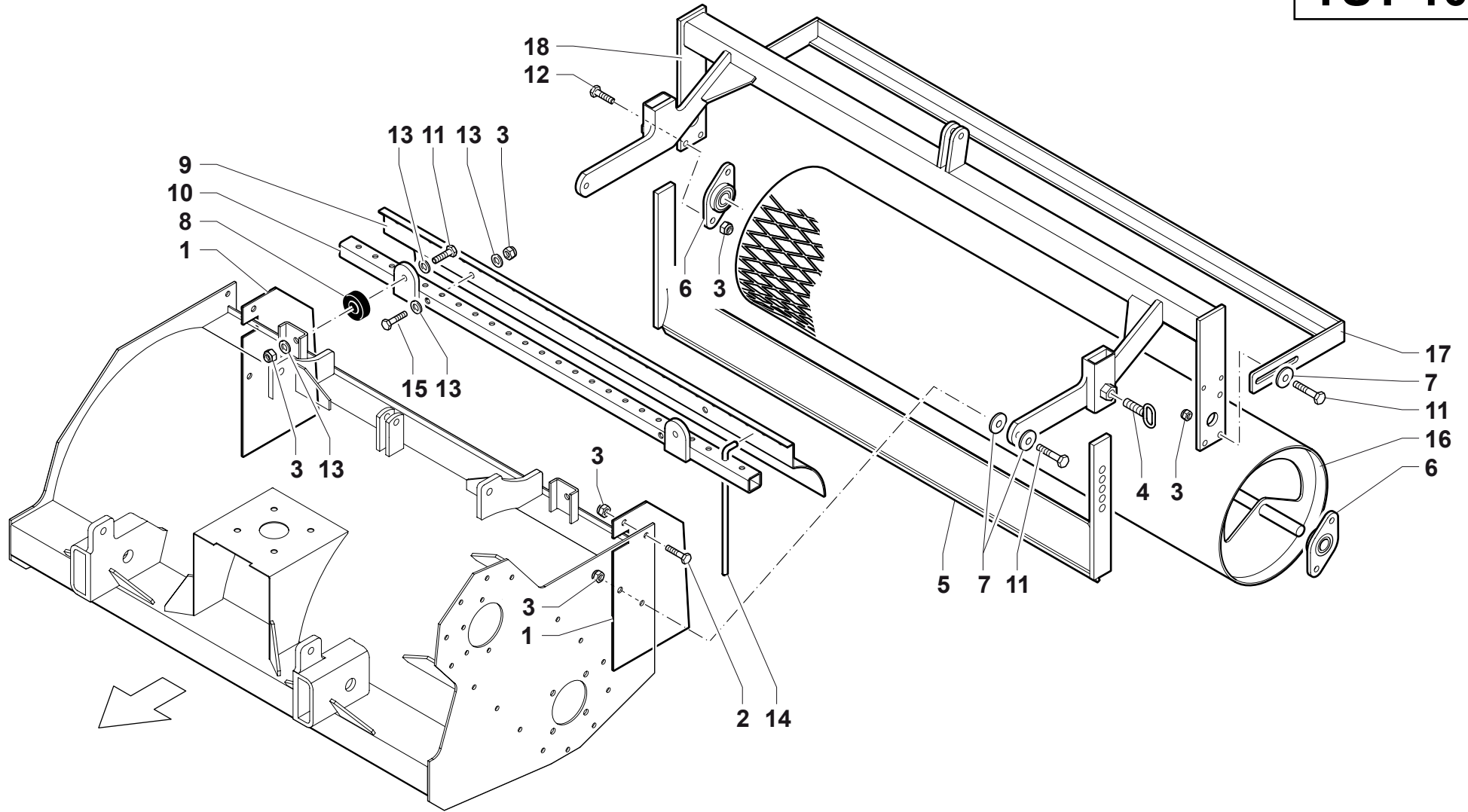



MONTAGGIO RULLO POSTERIORE E GRIGLIA
REAR ROLLER AND GRATE ASSEMBLY
MONTAGE ROULEAUX ARRIERE ET GRILLAGE
MONTAGE HINTERE ROLLEN UND GITTERROST
MONTAGE RODILLOS TRASERO Y ENREJADO

Tav. 02.0

TST-113

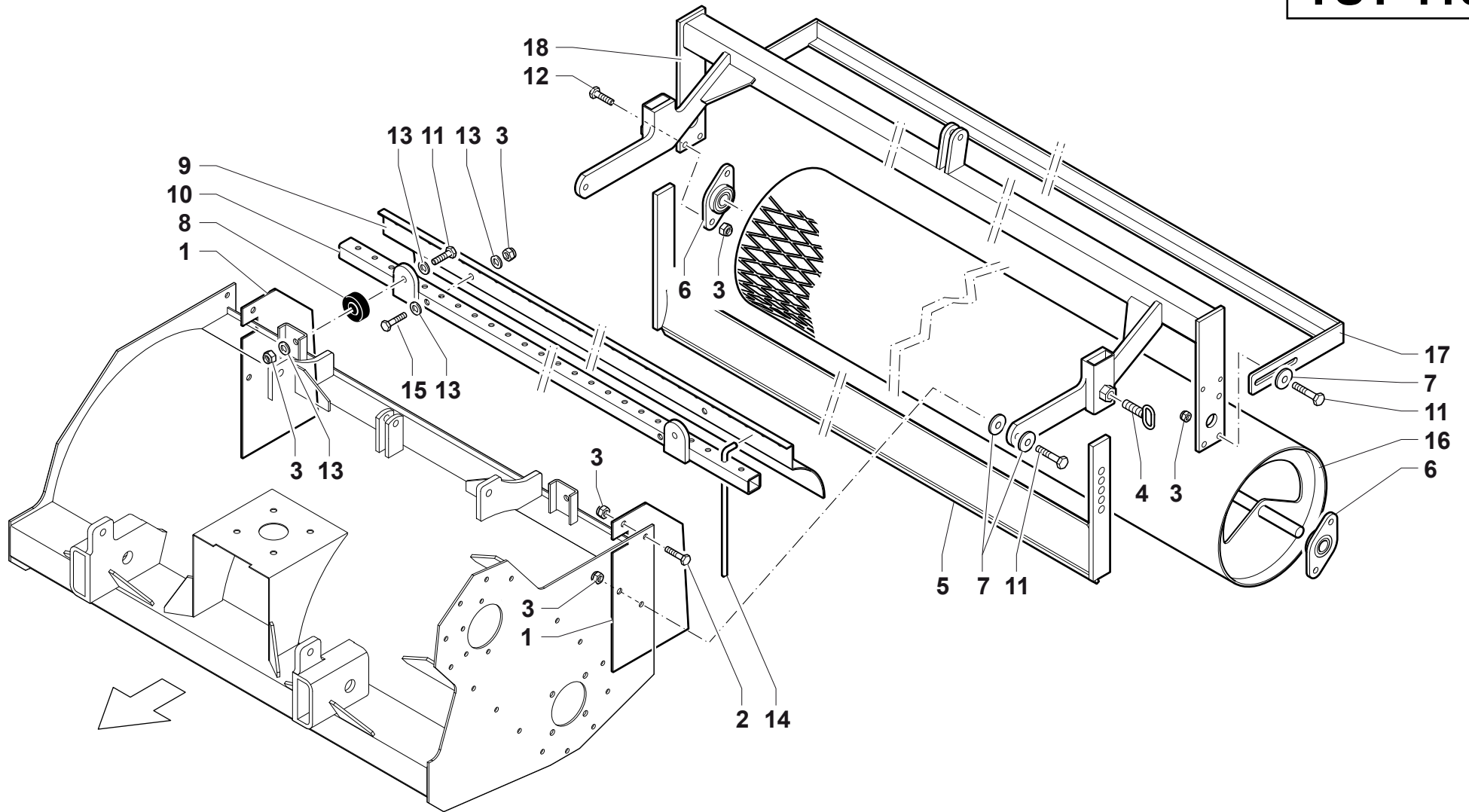



MONTAGGIO RULLO POSTERIORE E GRIGLIA
REAR ROLLER AND GRATE ASSEMBLY
MONTAGE ROULEAUX ARRIERE ET GRILLAGE
MONTAGE HINTERE ROLLEN UND GITTERROST
MONTAGE RODILLOS TRASERO Y ENREJADO

Tav. 03.0

TST-130

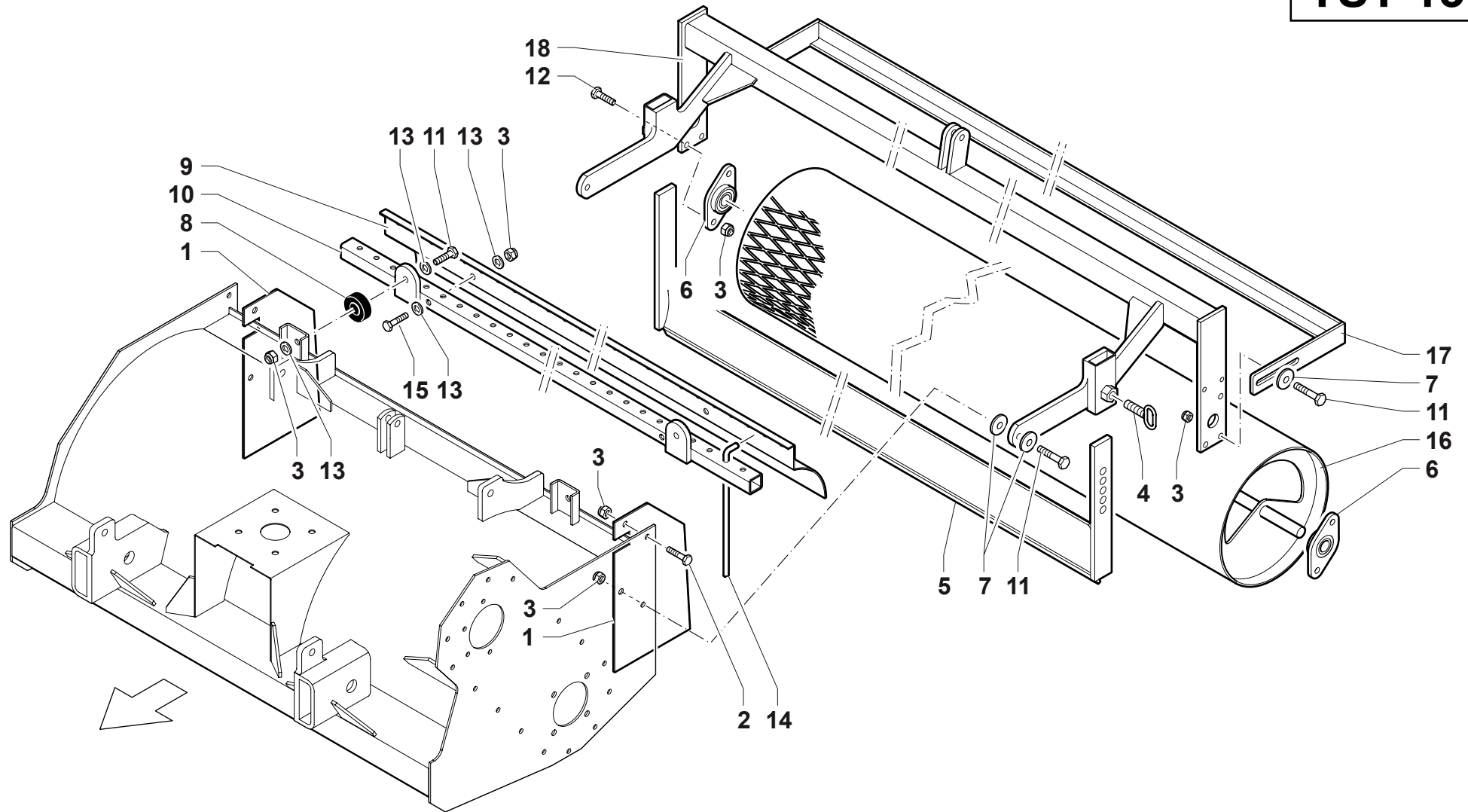



TRASMISSIONE
TRANSMISSION
TRANSMISSION
TRANSMISSION
TRANSMISSION

Tav. 04.0

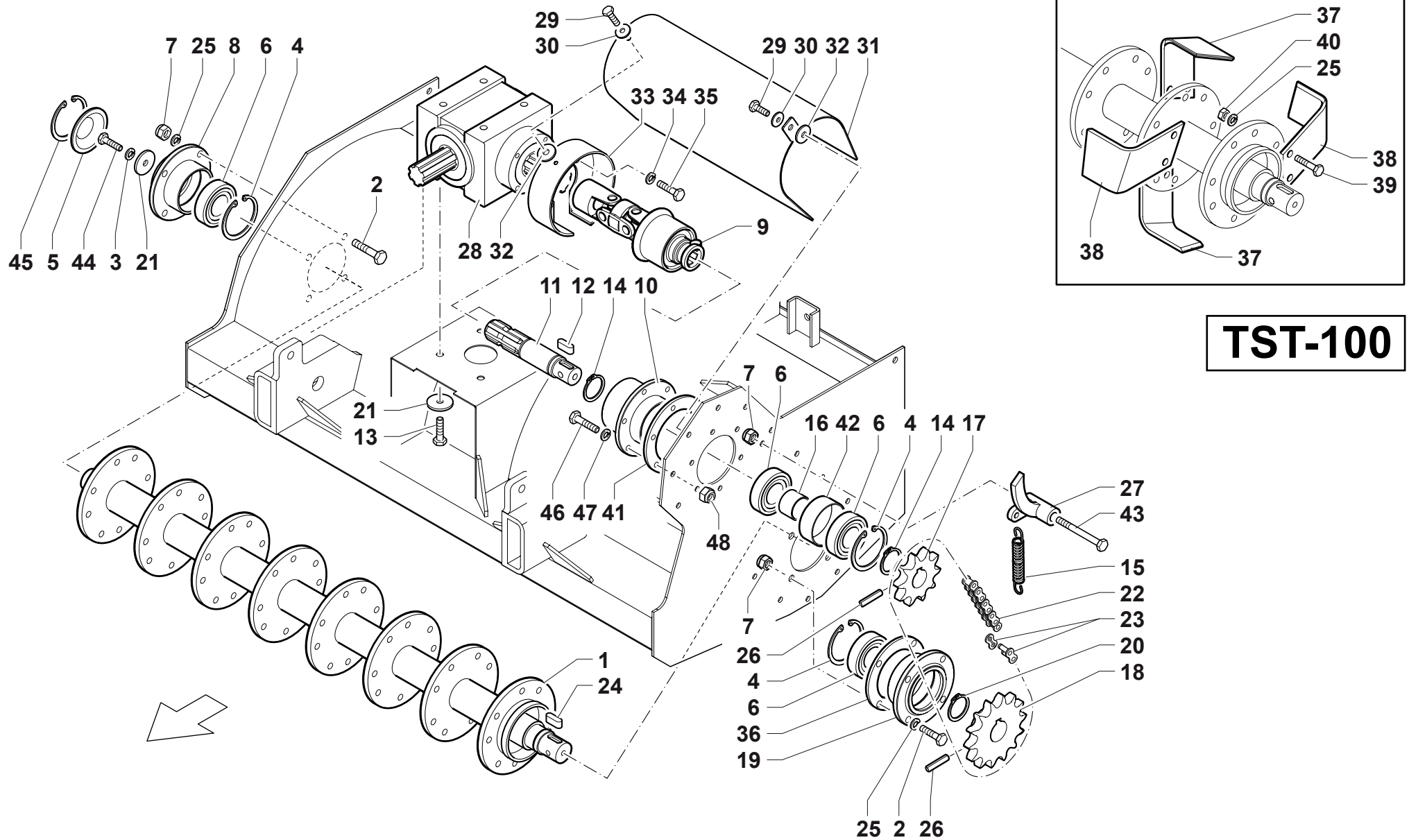

TST-100

<i>Rif.</i>	<i>CODICE</i>	<i>Qnt</i>	<i>Descrizione</i>	<i>Description</i>	<i>Designation</i>	<i>Benennung</i>	<i>Denominaciones</i>
1	060.003	1	ALBERO PORTACOLTELLI	CUTTER HOLDING SHAFT	ARBRE PORTE COUTEAUX	MESSERWELLE	ÁRBOL PORTRA CUCHILLAS
2	21.0.0.10030	8	VITE	SCREW	VIS	SCHRAUBE	TORNILLO
3	16.01.00.010	1	RONDELLA ELASTICA	SPRING WASHER	RONDELLE ELASTIQUE	FEDERSCHEIBE	ARANDELA ELASTICA
4	18.00.01.072	3	ANELLO ELASTICO	SNAP RING	ANNEAU RESSORT	SICHERUNGSRING	ANILLO ELASTICO
5	060.087	1	COPERCHIO	COVER	COUVERCLE	DECKEL	TAPA
6	A6207	4	CUSCINETTO	BEARING	PALIER	LAGERSCHALE	COJINETE
7	30.01.00.010	9	DADO AUTOBLOCCANTE	STOP NUT	ECROU DE SURETE	SPERRMUTTER	TUERCA AUTOTRABADORA
8	060.006	1	MOZZO PORTA ALBERO	SHAFT HUB	MOYEU ARBRE	WELLENNABE	CUBO EJE
9	050.111	1	GIUNTO CON LIMITATORE	JOINT WITH LIMIT STOP	JOINT AVEC BUTEE	GELENK MIT ENDANSCHLAG	JUNTA CON LIMITADOR
10	060.007	1	MOZZO PORTA ALBERO	SHAFT HUB	MOYEU ARBRE	WELLENNABE	CUBO EJE
11	060.009	1	ALBERO DI TRASMISSIONE	PROPELLER SHAFT	ARBRE DE TRANSMISSION	WELLE TRANSMISSION	ARBOL DE TRANSMISIÓN
12	35.1.0.08030	1	LINGUETTA	KEY	CLAVETTE	KEIL	CHAVETA
13	21.0.0.10030	1	VITE	SCREW	VIS	SCHRAUBE	TORNILLO
14	18.01.00.035	2	ANELLO ELASTICO	SNAP RING	ANNEAU RESSORT	SICHERUNGSRING	ANILLO ELASTICO
15	050.117	1	MOLLA	SPRING	RESSORT	FEDER	RESORTE
16	031.045	1	DISTANZIALE	SPACER	ENTRETOISE	ABSTANDSTUECK	SEPARADOR
17	060.013	1	PIGNONE	PINION	PIGNON	RITZEL	PINON
18	060.014	1	CORONA	RING GEAR	COURONNE	KRANZ	CORONA
19	060.005	1	MOZZO PORTA ALBERO	SHAFT HUB	MOYEU ARBRE	WELLENNABE	CUBO EJE
20	18.01.00.040	1	ANELLO ELASTICO	SNAP RING	ANNEAU RESSORT	SICHERUNGSRING	ANILLO ELASTICO
21	15.1.0.01.010	2	RONDELLA	WASHER	RONDELLE	SCHEIBE	ARANDELA
22	050.105	1	CATENA	CHAIN	CHAÎNE	KETTE	CADENA
23	050.105/A	1	MAGLIA DI GIUNZIONE	CHAIN JOINT	JOINT DE CHAÎNE	STECKGLIED	UNIÓN DE CADENA
24	35.1.0.10030	1	LINGUETTA	KEY	CLAVETTE	KEIL	CHAVETA
25	16.01.01.010	16	RONDELLA ELASTICA	SPRING WASHER	RONDELLE ELASTIQUE	FEDERSCHEIBE	ARANDELA ELASTICA
26	38.1.1.10050	2	SPINA ELASTICA	SPLIT PIN	BROCHE ELASTIQUE	ZAPFEN FEDRIG	PERNO ELASTICO
27	060.016	1	TENDICATENA	CHAIN STRETCHER	TENDEUR DE CHAINE	KETTENSPIANN	TENJOR DE CADENA
28	050.109	1	RIDUTTORE	REDUCTION GEAR	REDUCTEUR	REDUKTIONSGETRIEBE	REDUCTOR
29	21.0.0.06020	2	VITE	SCREW	VIS	SCHRAUBE	TORNILLO
30	15.0.0.00.006	2	RONDELLA PIANA	PLAIN WASHER	RONDELLE PLANE	ABSTANDSRING	ARANDELA LLANA
31	060.063	1	CARTER DI PROTEZIONE	GUARD	PROTECTION	SCHUTZKASTEN	PROTECCIÓN





TRASMISSIONE
TRANSMISSION
TRANSMISSION
TRANSMISSION
TRANSMISSION

Tav. 05.0

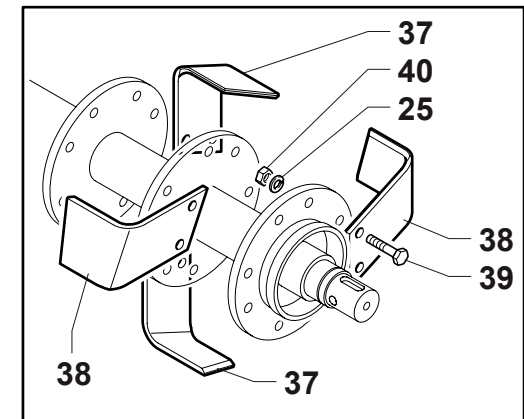
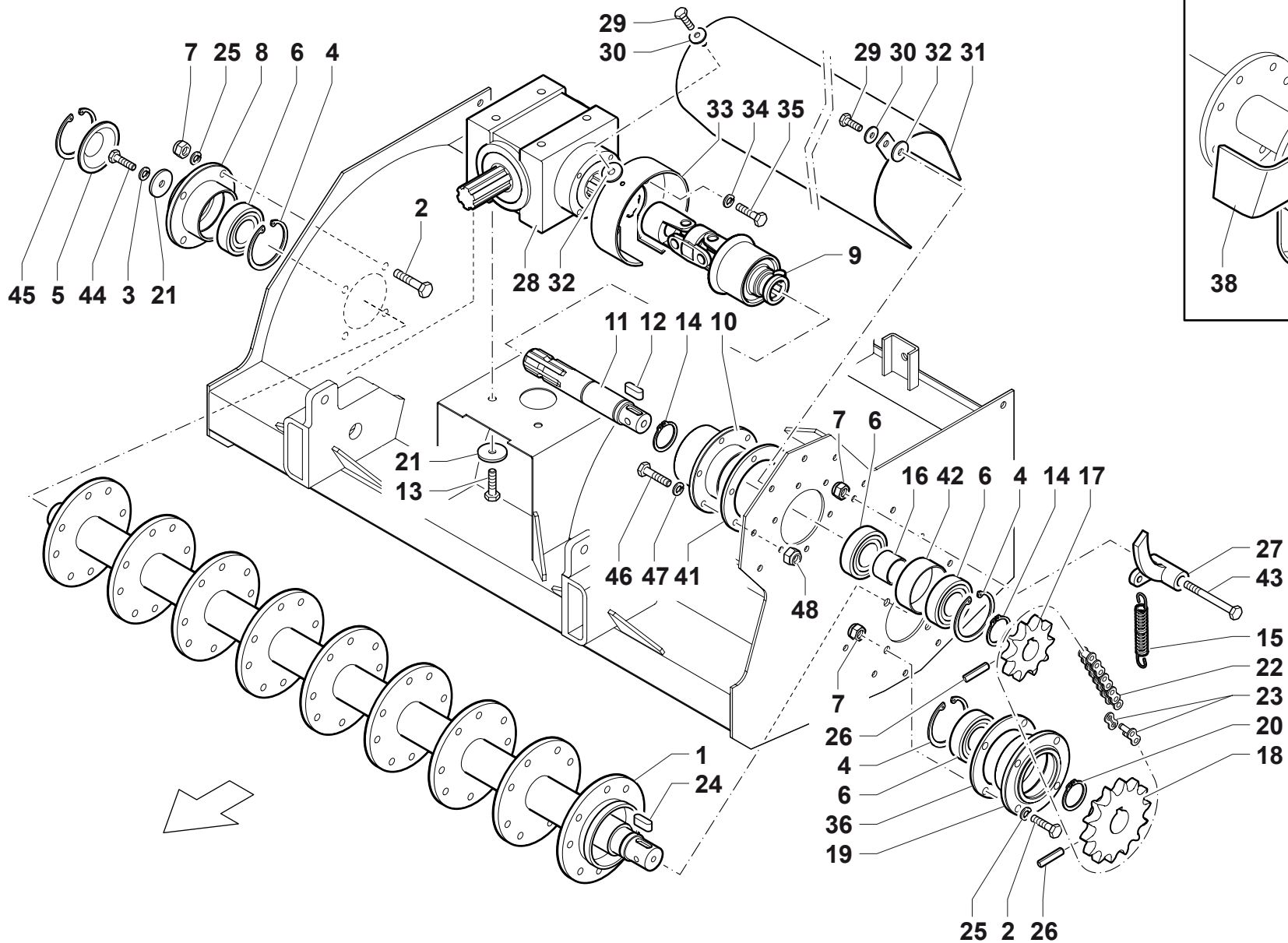

TST-113

<i>Rif.</i>	<i>CODICE</i>	<i>Qty</i>	<i>Descrizione</i>	<i>Description</i>	<i>Designation</i>	<i>Benennung</i>	<i>Denominaciones</i>
1	060.047	1	ALBERO PORTACOLTELLI	CUTTER HOLDING SHAFT	ARBRE PORTE COUTEAUX	MESSERWELLE	ÁRBOL PORTRA CUCHILLAS
2	21.0.0.10030	8	VITE	SCREW	VIS	SCHRAUBE	TORNILLO
3	16.01.00.010	1	RONDELLA ELASTICA	SPRING WASHER	RONDELLE ELASTIQUE	FEDERSCHEIBE	ARANDELA ELASTICA
4	18.00.01.072	3	ANELLO ELASTICO	SNAP RING	ANNEAU RESSORT	SICHERUNGSRING	ANILLO ELASTICO
5	060.087	1	COPERCHIO	COVER	COUVERCLE	DECKEL	TAPA
6	A6207	4	CUSCINETTO	BEARING	PALIER	LAGERSCHALE	COJINETE
7	30.01.00.010	9	DADO AUTOBLOCCANTE	STOP NUT	ECROU DE SURETE	SPERRMUTTER	TUERCA AUTOTRABADORA
8	060.006	1	MOZZO PORTA ALBERO	SHAFT HUB	MOYEU ARBRE	WELLENNABE	CUBO EJE
9	050.249	1	GIUNTO CON LIMITATORE	JOINT WITH LIMIT STOP	JOINT AVEC BUTEE	GELENK MIT ENDANSCHLAG	JUNTA CON LIMITADOR
10	060.007	1	MOZZO PORTA ALBERO	SHAFT HUB	MOYEU ARBRE	WELLENNABE	CUBO EJE
11	060.069	1	ALBERO DI TRASMISSIONE	PROPELLER SHAFT	ARBRE DE TRANSMISSION	WELLE TRANSMISSION	ARBOL DE TRANSMISIÓN
12	35.1.0.08030	1	LINGUETTA	KEY	CLAVETTE	KEIL	CHAVETA
13	21.0.0.10030	1	VITE	SCREW	VIS	SCHRAUBE	TORNILLO
14	18.01.00.035	2	ANELLO ELASTICO	SNAP RING	ANNEAU RESSORT	SICHERUNGSRING	ANILLO ELASTICO
15	050.117	1	MOLLA	SPRING	RESSORT	FEDER	RESORTE
16	031.045	1	DISTANZIALE	SPACER	ENTRETOISE	ABSTANDSTUECK	SEPARADOR
17	060.013	1	PIGNONE	PINION	PIGNON	RITZEL	PINON
18	060.014	1	CORONA	RING GEAR	COURONNE	KRANZ	CORONA
19	060.005	1	MOZZO PORTA ALBERO	SHAFT HUB	MOYEU ARBRE	WELLENNABE	CUBO EJE
20	18.01.00.040	1	ANELLO ELASTICO	SNAP RING	ANNEAU RESSORT	SICHERUNGSRING	ANILLO ELASTICO
21	15.1.0.01.010	2	RONDELLA	WASHER	RONDELLE	SCHEIBE	ARANDELA
22	050.105	1	CATENA	CHAIN	CHAÎNE	KETTE	CADENA
23	050.105/A	1	MAGLIA DI GIUNZIONE	CHAIN JOINT	JOINT DE CHAÎNE	STECKGLIED	UNIÓN DE CADENA
24	35.1.0.10030	1	LINGUETTA	KEY	CLAVETTE	KEIL	CHAVETA
25	16.01.01.010	24	RONDELLA ELASTICA	SPRING WASHER	RONDELLE ELASTIQUE	FEDERSCHEIBE	ARANDELA ELASTICA
26	38.1.1.10050	2	SPINA ELASTICA	SPLIT PIN	BROCHE ELASTIQUE	ZAPFEN FEDRIG	PERNO ELASTICO
27	060.016	1	TENDICATENA	CHAIN STRETCHER	TENDEUR DE CHAINE	KETTENSPIANN	TENJOR DE CADENA
28	050.109	1	RIDUTTORE	REDUCTION GEAR	REDUCTEUR	REDUKTIONSGETRIEBE	REDUCTOR
29	21.0.0.06020	2	VITE	SCREW	VIS	SCHRAUBE	TORNILLO
30	15.0.0.00.006	2	RONDELLA PIANA	PLAIN WASHER	RONDELLE PLANE	ABSTANDSRING	ARANDELA LLANA
31	060.048	1	CARTER DI PROTEZIONE	GUARD	PROTECTION	SCHUTZKASTEN	PROTECCIÓN





TRASMISSIONE
TRANSMISSION
TRANSMISSION
TRANSMISSION
TRANSMISSION

Tav. 06.0

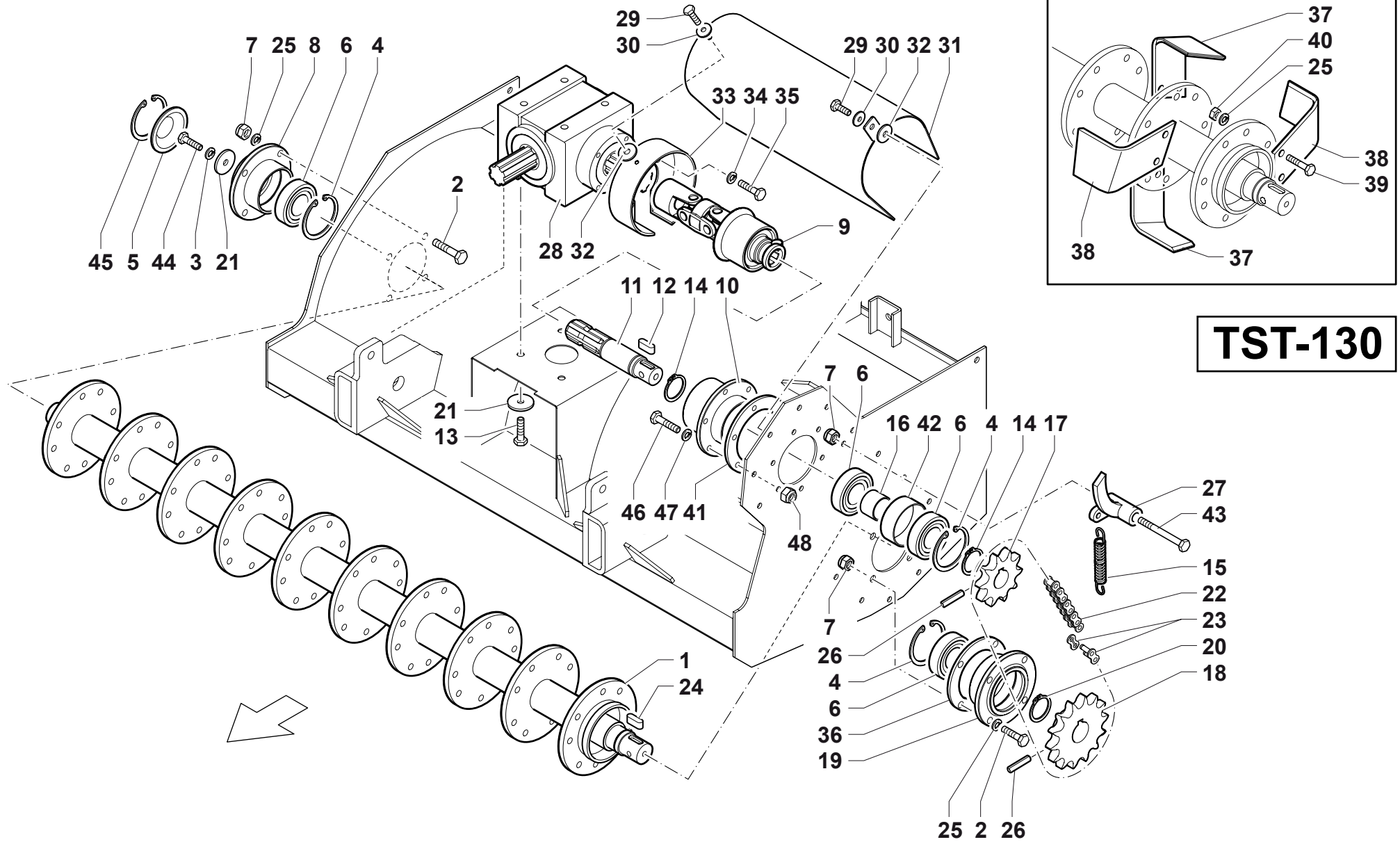

TST-130

<i>Rif.</i>	<i>CODICE</i>	<i>Qnt</i>	<i>Descrizione</i>	<i>Description</i>	<i>Designation</i>	<i>Benennung</i>	<i>Denominaciones</i>
1	060.044	1	ALBERO PORTACOLTELLI	CUTTER HOLDING SHAFT	ARBRE PORTE COUTEAUX	MESSERWELLE	ÁRBOL PORTRA CUCHILLAS
2	21.0.0.10030	8	VITE	SCREW	VIS	SCHRAUBE	TORNILLO
3	16.01.00.010	1	RONDELLA ELASTICA	SPRING WASHER	RONDELLE ELASTIQUE	FEDERSCHEIBE	ARANDELA ELASTICA
4	18.00.01.072	3	ANELLO ELASTICO	SNAP RING	ANNEAU RESSORT	SICHERUNGSRING	ANILLO ELASTICO
5	060.087	1	COPERCHIO	COVER	COUVERCLE	DECKEL	TAPA
6	A6207	4	CUSCINETTO	BEARING	PALIER	LAGERSCHALE	COJINETE
7	30.01.00.010	9	DADO AUTOBLOCCANTE	STOP NUT	ECROU DE SURETE	SPERRMUTTER	TUERCA AUTOTRABADORA
8	060.006	1	MOZZO PORTA ALBERO	SHAFT HUB	MOYEU ARBRE	WELLENNABE	CUBO EJE
9	050.341	1	GIUNTO CON LIMITATORE	JOINT WITH LIMIT STOP	JOINT AVEC BUTEE	GELENK MIT ENDANSCHLAG	JUNTA CON LIMITADOR
10	060.007	1	MOZZO PORTA ALBERO	SHAFT HUB	MOYEU ARBRE	WELLENNABE	CUBO EJE
11	060.106	1	ALBERO DI TRASMISSIONE	PROPELLER SHAFT	ARBRE DE TRANSMISSION	WELLE TRANSMISSION	ARBOL DE TRANSMISIÓN
12	35.1.0.08030	1	LINGUETTA	KEY	CLAVETTE	KEIL	CHAVETA
13	21.0.0.10030	1	VITE	SCREW	VIS	SCHRAUBE	TORNILLO
14	18.01.00.035	2	ANELLO ELASTICO	SNAP RING	ANNEAU RESSORT	SICHERUNGSRING	ANILLO ELASTICO
15	050.117	1	MOLLA	SPRING	RESSORT	FEDER	RESORTE
16	031.045	1	DISTANZIALE	SPACER	ENTRETOISE	ABSTANDSTUECK	SEPARADOR
17	060.013	1	PIGNONE	PINION	PIGNON	RITZEL	PINON
18	060.014	1	CORONA	RING GEAR	COURONNE	KRANZ	CORONA
19	060.005	1	MOZZO PORTA ALBERO	SHAFT HUB	MOYEU ARBRE	WELLENNABE	CUBO EJE
20	18.01.00.040	1	ANELLO ELASTICO	SNAP RING	ANNEAU RESSORT	SICHERUNGSRING	ANILLO ELASTICO
21	15.1.0.01.010	2	RONDELLA	WASHER	RONDELLE	SCHEIBE	ARANDELA
22	050.105	1	CATENA	CHAIN	CHAÎNE	KETTE	CADENA
23	050.105/A	1	MAGLIA DI GIUNZIONE	CHAIN JOINT	JOINT DE CHAÎNE	STECKGLIED	UNIÓN DE CADENA
24	35.1.0.10030	1	LINGUETTA	KEY	CLAVETTE	KEIL	CHAVETA
25	16.01.01.010	24	RONDELLA ELASTICA	SPRING WASHER	RONDELLE ELASTIQUE	FEDERSCHEIBE	ARANDELA ELASTICA
26	38.1.1.10050	2	SPINA ELASTICA	SPLIT PIN	BROCHE ELASTIQUE	ZAPFEN FEDRIG	PERNO ELASTICO
27	060.016	1	TENDICATENA	CHAIN STRETCHER	TENDEUR DE CHAINE	KETTENSPIANN	TENJOR DE CADENA
28	050.109	1	RIDUTTORE	REDUCTION GEAR	REDUCTEUR	REDUKTIONSGETRIEBE	REDUCTOR
29	21.0.0.06020	2	VITE	SCREW	VIS	SCHRAUBE	TORNILLO
30	15.0.0.00.006	2	RONDELLA PIANA	PLAIN WASHER	RONDELLE PLANE	ABSTANDSRING	ARANDELA LLANA
31	060.110	1	CARTER DI PROTEZIONE	GUARD	PROTECTION	SCHUTZKASTEN	PROTECCIÓN





TELAIO - CARTER E ACCESSORI
FRAME - COVERS AND ACCESSORIES
CHASSIS - CARTERS ET ACCESSOIRES
RAHMEN - SCHUTZABDECKUNGEN UND ZEBÖHR
BASTIDOR - CÁRTERES Y ACCESORIOS

Tav. 07.0

TST-100
TST-113
TST-130

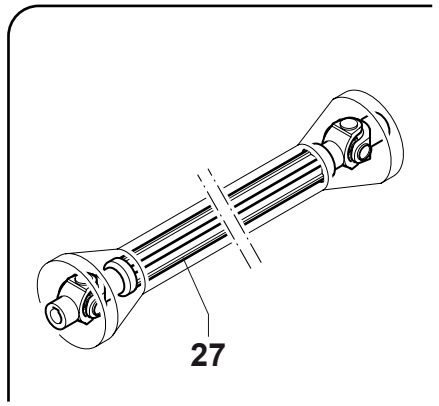
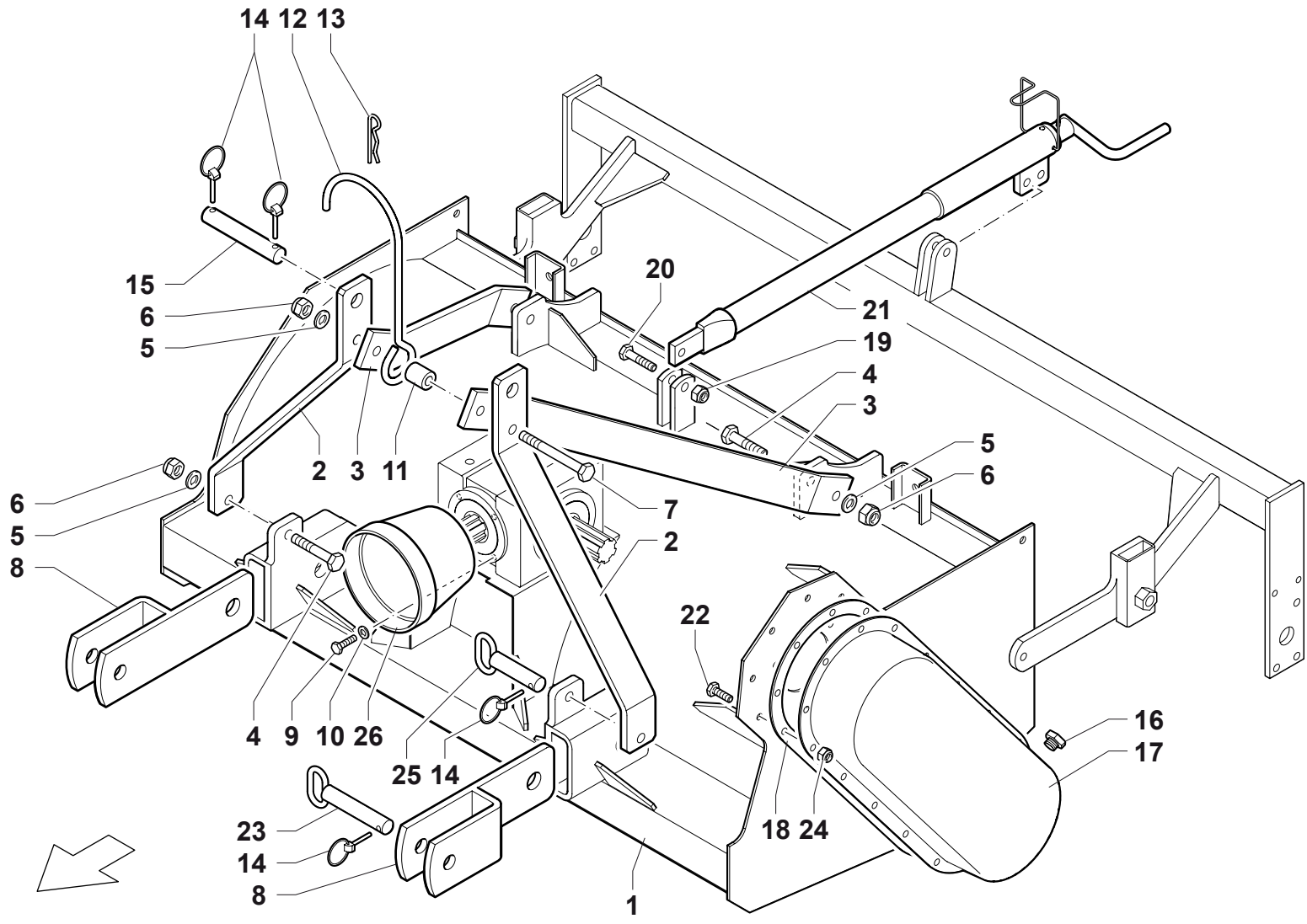

Rif.	CODICE	Qty	Descrizione	Description	Designation	Benennung	Denominaciones
1	060.001	1	TELAIO TST-100	FRAME	CHASSIS	RAHMEN	BASTIDOR
1	060.050	1	TELAIO TST-113	FRAME	CHASSIS	RAHMEN	BASTIDOR
1	060.105	1	TELAIO TST-130	FRAME	CHASSIS	RAHMEN	BASTIDOR
2	034.008	2	LAMA ANTERIORE	FRONT TIE-ROD	TIRANT AVANT	VORDERE ZUGSTANGE	TIRANTE ANTERIOR
3	034.009	2	LAMA POSTERIORE	REAR TIE-ROD	TIRANT ARRIERE	HINTERE ZUGSTANGE	TIRANTE POSTERIOR
4	20.0.0.12045	4	VITE	SCREW	VIS	SCHRAUBE	TORNILLO
5	15.0.0.00.012	5	RONDELLA PIANA	PLAIN WASHER	RONDELLE PLANE	ABSTANDSRING	ARANDELA LLANA
6	30.02.00.012	5	DADO AUTOBLOCCANTE	STOP NUT	ECROU DE SURETE	SPERRMUTTER	TUERCA AUTOTRABADORA
7	20.0.0.12090	1	VITE	SCREW	VIS	SCHRAUBE	TORNILLO
8	060.026	2	BRACCIO	ARM	BRAS	ARM	BRAZO
9	21.0.0.08016	4	VITE	SCREW	VIS	SCHRAUBE	TORNILLO
10	15.0.0.00.008	4	RONDELLA PIANA	PLAIN WASHER	RONDELLE PLANE	ABSTANDSRING	ARANDELA LLANA
11	034.012	1	DISTANZIALE	SPACER	ENTRETOISE	ABSTANDSTUECK	SEPARADOR
12	093.140	1	GANCIO	HOOK	CROCHET	HAKEN	GANCHO
13		1	COPIGLIA A "R"	COTTER PIN	GOUPILLE	SPLINT	CLAVIJA
14	050.159	1	SPINOTTO A SCATTO	RELEASE PIN	BROCHE DE SÛRETE	SPRINGSTECKER	PASADOR DISPARO
15	000.017	1	PERNO	PIN	PIVOT	BOLZEN	PERNO
16	050.001	1	TAPPO	PLUG	BOUCHON	STOPFEN	TAPÓN
17	060.004	1	CARTER CATENA	CHAIN CASING	CARTER CHAINE	GEHÄUSEKETTE	CARTER CADENA
18	050.106	1	GUARNIZIONE	SEAL	JOINT	DICHTUNG	GUARNICIÓN
19	30.02.00.010	2	DADO AUTOBLOCCANTE	STOP NUT	ECROU DE SURETE	SPERRMUTTER	TUERCA AUTOTRABADORA
20	20.0.0.10045	2	VITE	SCREW	VIS	SCHRAUBE	TORNILLO
21	060.030	1	REGISTRO	ADJUSTER	REGLAGE	REGULATOR	AJUSTE
22	21.0.1.08016	16	VITE	SCREW	VIS	SCHRAUBE	TORNILLO
23	000.016	2	PERNO LUNGO	HIGH PIN	TOURILLON LONG	HOHER BOLZEN	PERNO ALTO
24	30.01.00.008	16	DADO AUTOBLOCCANTE	STOP NUT	ECROU DE SURETE	SPERRMUTTER	TUERCA AUTOTRABADORA
25	000.056	2	PERNO CORTO	THIN PIN	TOURILLON COURT	NIEDRIGER BOLZEN	PERNO BAJO
26	050.052	1	CUFFIA GIUNTO	JOINT HOUSING	PROTECTEUR JOINT	KUPPLUNGSMANSCHETTE	PROTECCIÓN ARTICULACIÓN
27	050.035	1	ALBERO CARDANICO L=550	CARDAN SHAFT	ARBRE CARDAN	KARDANWELLE	ARBOL CARDANICO
27	050.128	1	ALBERO CARDANICO L=600	CARDAN SHAFT	ARBRE CARDAN	KARDANWELLE	ARBOL CARDANICO
27	050.216	1	ALBERO CARDANICO L=700	CARDAN SHAFT	ARBRE CARDAN	KARDANWELLE	ARBOL CARDANICO





TRASMISSIONE IDRAULICA
HYDRAULIC TRANSMISSION
TRANSMISSION HYDRAULIQUE
HYDRAULIKANTRIEB
TRANSMISSION HIDRÁULICA

Tav. 08.0

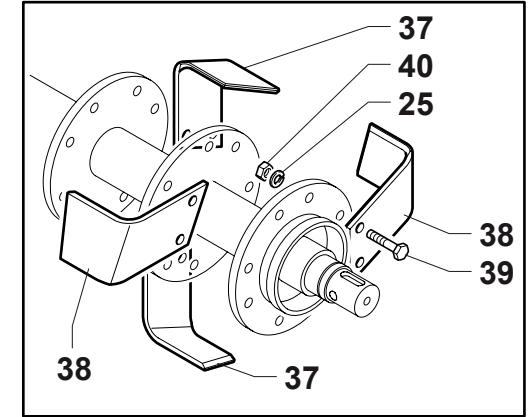
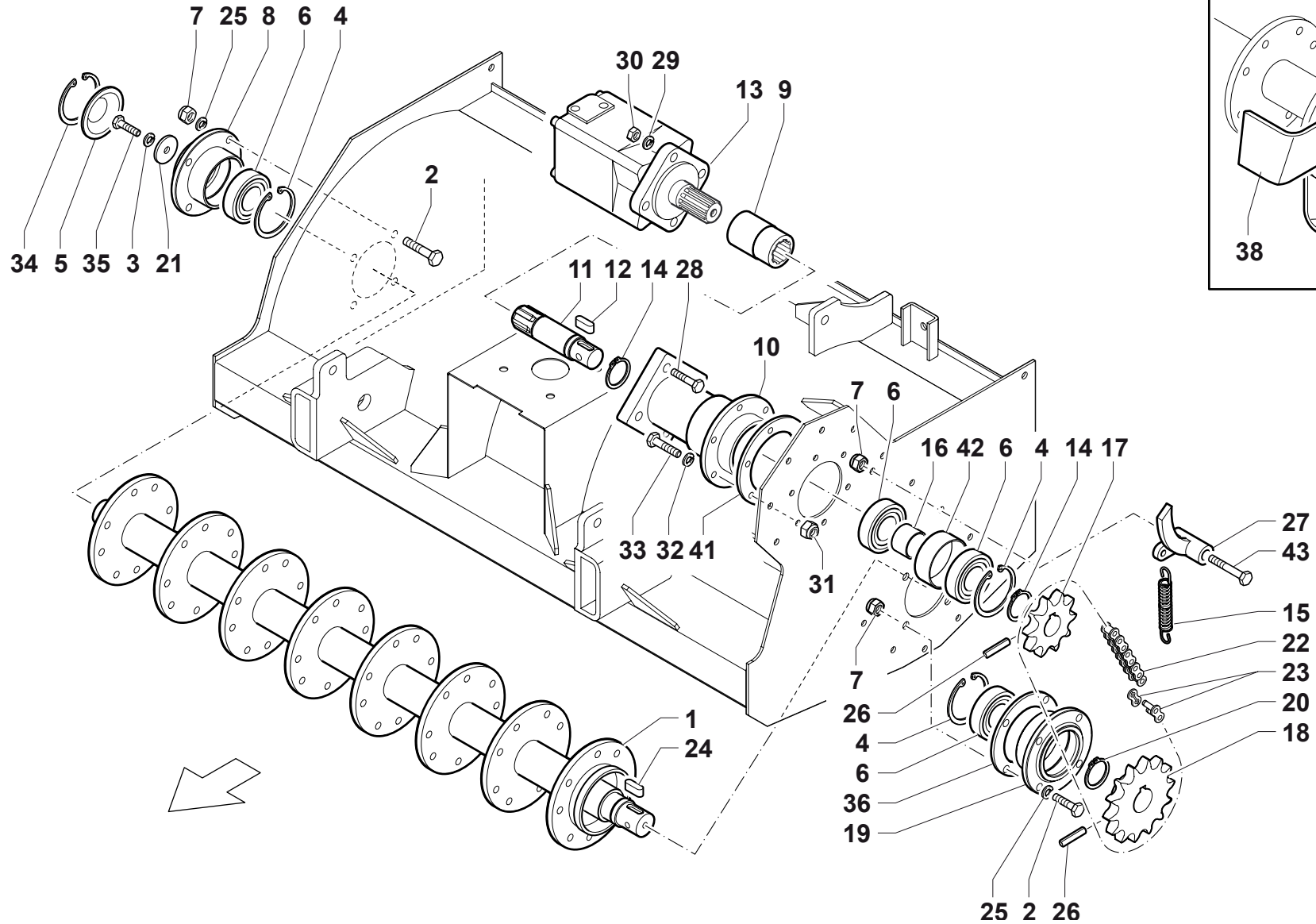

TST 100H

<i>Rif.</i>	<i>CODICE</i>	<i>Qnt</i>	<i>Descrizione</i>	<i>Description</i>	<i>Designation</i>	<i>Benennung</i>	<i>Denominaciones</i>
1	060.003	1	ALBERO PORTACOLTELLI	CUTTER HOLDING SHAFT	ARBRE PORTE COUTEAUX	MESSERWELLE	ÁRBOL PORTRA CUCHILLAS
2	21.0.0.10030	8	VITE	SCREW	VIS	SCHRAUBE	TORNILLO
3	16.01.00.010	1	RONDELLA ELASTICA	SPRING WASHER	RONDELLE ELASTIQUE	FEDERSCHEIBE	ARANDELA ELASTICA
4	18.00.01.072	3	ANELLO ELASTICO	SNAP RING	ANNEAU RESSORT	SICHERUNGSRING	ANILLO ELASTICO
5	060.087	1	COPERCHIO	COVER	COUVERCLE	DECKEL	TAPA
6	A6207	4	CUSCINETTO	BEARING	PALIER	LAGERSCHALE	COJINETE
7	30.01.00.010	9	DADO AUTOBLOCCANTE	STOP NUT	ECROU DE SURETE	SPERRMUTTER	TUERCA AUTOTRABADORA
8	060.006	1	MOZZO PORTA ALBERO	SHAFT HUB	MOYEU ARBRE	WELLENNABE	CUBO EJE
9	015.012	1	MANICOTTO TRASMISSIONE	TRANSMISSION SLEEVE	MANCHON TRANSMISSION	TRANSMISSIONSROHR	MANGUITO TRANSMISIÓN
10	015.011	1	SUPPORTO	SUPPORT	SUPPORT	LAGER	SOPORTE
11	060.010	1	ALBERO DI TRASMISSIONE	PROPELLER SHAFT	ARBRE DE TRANSMISSION	WELLE TRANSMISSION	ARBOL DE TRANSMISIÓN
12	35.1.0.08030	1	LINGUETTA	KEY	CLAVETTE	KEIL	CHAVETA
13	050.045	1	MOTORE IDRAULICO	HYDRAULIC MOTOR	MOTEUR HYDRAULIQUE	HYDRAULIKMOTOR	MOTOR HIDRAULICO
14	18.01.00.035	2	ANELLO ELASTICO	SNAP RING	ANNEAU RESSORT	SICHERUNGSRING	ANILLO ELASTICO
15	050.117	1	MOLLA	SPRING	RESSORT	FEDER	RESORTE
16	031.045	1	DISTANZIALE	SPACER	ENTRETOISE	ABSTANDSTUECK	SEPARADOR
17	060.013	1	PIGNONE	PINION	PIGNON	RITZEL	PINON
18	060.014	1	CORONA	RING GEAR	COURONNE	KRANZ	CORONA
19	060.005	1	MOZZO PORTA ALBERO	SHAFT HUB	MOYEU ARBRE	WELLENNABE	CUBO EJE
20	18.01.00.040	1	ANELLO ELASTICO	SNAP RING	ANNEAU RESSORT	SICHERUNGSRING	ANILLO ELASTICO
21	15.1.0.01.010	1	RONDELLA	WASHER	RONDELLE	SCHEIBE	ARANDELA
22	050.105	1	CATENA	CHAIN	CHAÎNE	KETTE	CADENA
23	050.105/A	1	MAGLIA DI GIUNZIONE	CHAIN JOINT	JOINT DE CHAÎNE	STECKGLIED	UNIÓN DE CADENA
24	35.1.0.10030	1	LINGUETTA	KEY	CLAVETTE	KEIL	CHAVETA
25	16.01.01.010	16	RONDELLA ELASTICA	SPRING WASHER	RONDELLE ELASTIQUE	FEDERSCHEIBE	ARANDELA ELASTICA
26	38.1.1.10050	2	SPINA ELASTICA	SPLIT PIN	BROCHE ELASTIQUE	ZAPFEN FEDRIG	PERNO ELASTICO
27	060.016	1	TENDICATENA	CHAIN STRETCHER	TENDEUR DE CHAINE	KETTENSPIANN	TENJOR DE CADENA
28	22.0.1.12055	4	VITE	SCREW	VIS	SCHRAUBE	TORNILLO
29	16.01.01.012	4	GROWER	GROWER	GROWER	GROWER	GROWER
30	31.02.00.0.12	4	DADO	NUT	ECROU	MUTTER	TUERCA
31	30.03.00.008	6	DADO AUTOBLOCCANTE	STOP NUT	ECROU DE SURETE	SPERRMUTTER	TUERCA AUTOTRABADORA





TRASMISSIONE IDRAULICA
HYDRAULIC TRANSMISSION
TRANSMISSION HYDRAULIQUE
HYDRAULIKANTRIEB
TRANSMISSION HIDRÁULICA

Tav. 09.0

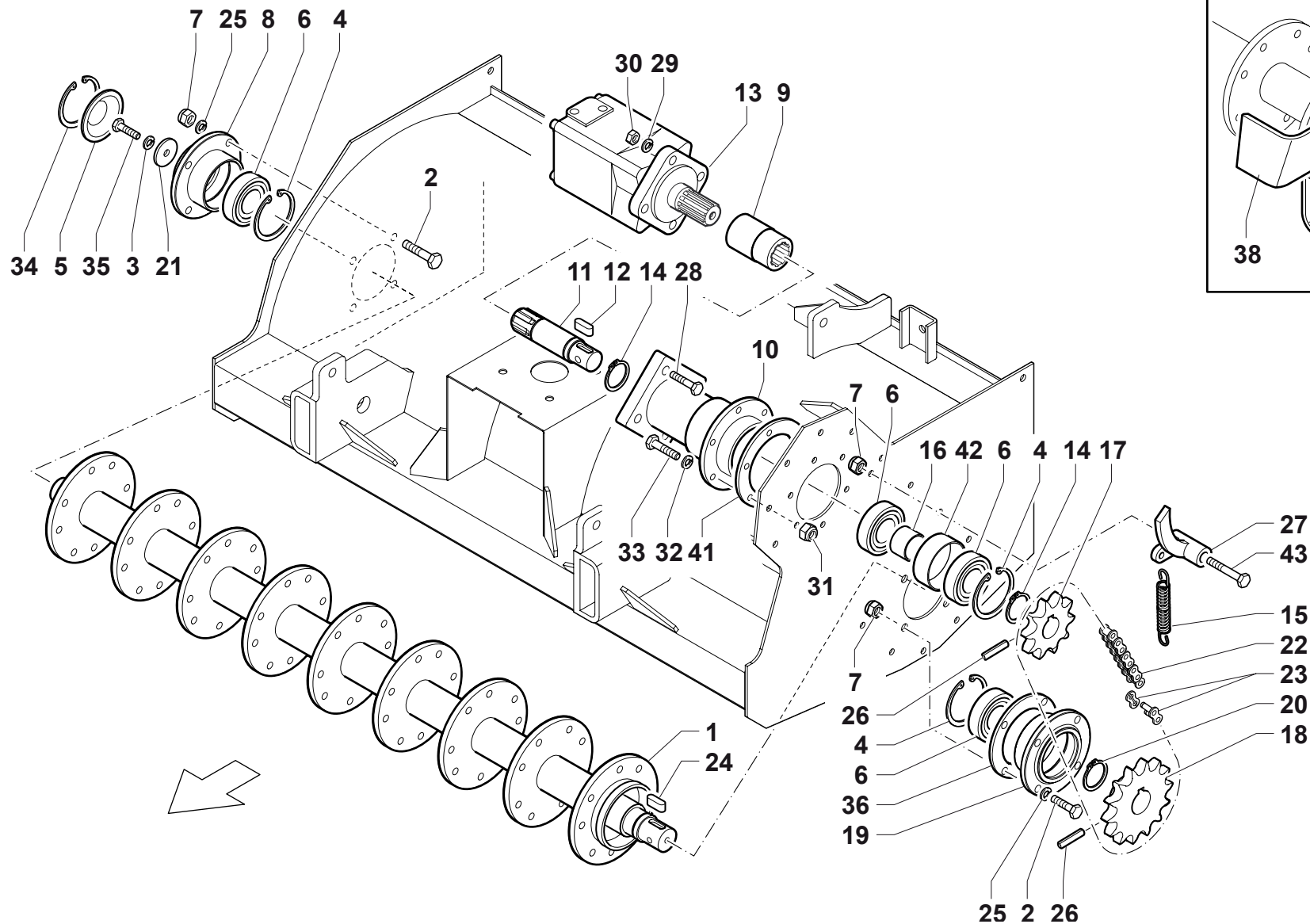

TST 113H

<i>Rif.</i>	<i>CODICE</i>	<i>Qnt</i>	<i>Descrizione</i>	<i>Description</i>	<i>Designation</i>	<i>Benennung</i>	<i>Denominaciones</i>
1	060.047	1	ALBERO PORTACOLTELLI	CUTTER HOLDING SHAFT	ARBRE PORTE COUTEAUX	MESSERWELLE	ÁRBOL PORTRA CUCHILLAS
2	21.0.0.10030	8	VITE	SCREW	VIS	SCHRAUBE	TORNILLO
3	16.01.00.010	1	RONDELLA ELASTICA	SPRING WASHER	RONDELLE ELASTIQUE	FEDERSCHEIBE	ARANDELA ELASTICA
4	18.00.01.072	3	ANELLO ELASTICO	SNAP RING	ANNEAU RESSORT	SICHERUNGSRING	ANILLO ELASTICO
5	060.087	1	COPERCHIO	COVER	COUVERCLE	DECKEL	TAPA
6	A6207	4	CUSCINETTO	BEARING	PALIER	LAGERSCHALE	COJINETE
7	30.01.00.010	9	DADO AUTOBLOCCANTE	STOP NUT	ECROU DE SURETE	SPERRMUTTER	TUERCA AUTOTRABADORA
8	060.006	1	MOZZO PORTA ALBERO	SHAFT HUB	MOYEU ARBRE	WELLENNABE	CUBO EJE
9	015.012	1	MANICOTTO TRASMISSIONE	TRANSMISSION SLEEVE	MANCHON TRANSMISSION	TRANSMISSIONSROHR	MANGUITO TRANSMISIÓN
10	015.011	1	SUPPORTO	SUPPORT	SUPPORT	LAGER	SOPORTE
11	060.010	1	ALBERO DI TRASMISSIONE	PROPELLER SHAFT	ARBRE DE TRANSMISSION	WELLE TRANSMISSION	ARBOL DE TRANSMISIÓN
12	35.1.0.08030	1	LINGUETTA	KEY	CLAVETTE	KEIL	CHAVETA
13	050.045	1	MOTORE IDRAULICO	HYDRAULIC MOTOR	MOTEUR HYDRAULIQUE	HYDRAULIKMOTOR	MOTOR HIDRAULICO
14	18.01.00.035	2	ANELLO ELASTICO	SNAP RING	ANNEAU RESSORT	SICHERUNGSRING	ANILLO ELASTICO
15	050.117	1	MOLLA	SPRING	RESSORT	FEDER	RESORTE
16	031.045	1	DISTANZIALE	SPACER	ENTRETOISE	ABSTANDSTUECK	SEPARADOR
17	060.013	1	PIGNONE	PINION	PIGNON	RITZEL	PINON
18	060.014	1	CORONA	RING GEAR	COURONNE	KRANZ	CORONA
19	060.005	1	MOZZO PORTA ALBERO	SHAFT HUB	MOYEU ARBRE	WELLENNABE	CUBO EJE
20	18.01.00.040	1	ANELLO ELASTICO	SNAP RING	ANNEAU RESSORT	SICHERUNGSRING	ANILLO ELASTICO
21	15.1.0.01.010	1	RONDELLA	WASHER	RONDELLE	SCHEIBE	ARANDELA
22	050.105	1	CATENA	CHAIN	CHAÎNE	KETTE	CADENA
23	050.105/A	1	MAGLIA DI GIUNZIONE	CHAIN JOINT	JOINT DE CHAÎNE	STECKGLIED	UNIÓN DE CADENA
24	35.1.0.10030	1	LINGUETTA	KEY	CLAVETTE	KEIL	CHAVETA
25	16.01.01.010	16	RONDELLA ELASTICA	SPRING WASHER	RONDELLE ELASTIQUE	FEDERSCHEIBE	ARANDELA ELASTICA
26	38.1.1.10050	2	SPINA ELASTICA	SPLIT PIN	BROCHE ELASTIQUE	ZAPFEN FEDRIG	PERNO ELASTICO
27	060.016	1	TENDICATENA	CHAIN STRETCHER	TENDEUR DE CHAINE	KETTENSPIANN	TENJOR DE CADENA
28	22.0.1.12055	4	VITE	SCREW	VIS	SCHRAUBE	TORNILLO
29	16.01.01.012	4	GROWER	GROWER	GROWER	GROWER	GROWER
30	31.02.00.0.12	4	DADO	NUT	ECROU	MUTTER	TUERCA
31	30.03.00.008	1	DADO AUTOBLOCCANTE	STOP NUT	ECROU DE SURETE	SPERRMUTTER	TUERCA AUTOTRABADORA



Tav. 09.0



TRASMISSIONE IDRAULICA
HYDRAULIC TRANSMISSION
TRANSMISSION HYDRAULIQUE
HYDRAULIKANTRIEB
TRANSMISIÓN HIDRÁULICA

Tav. 10.0

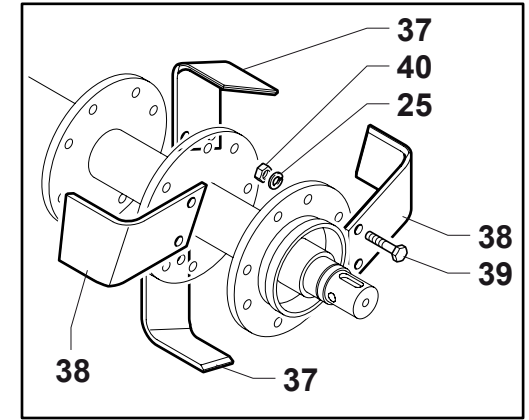
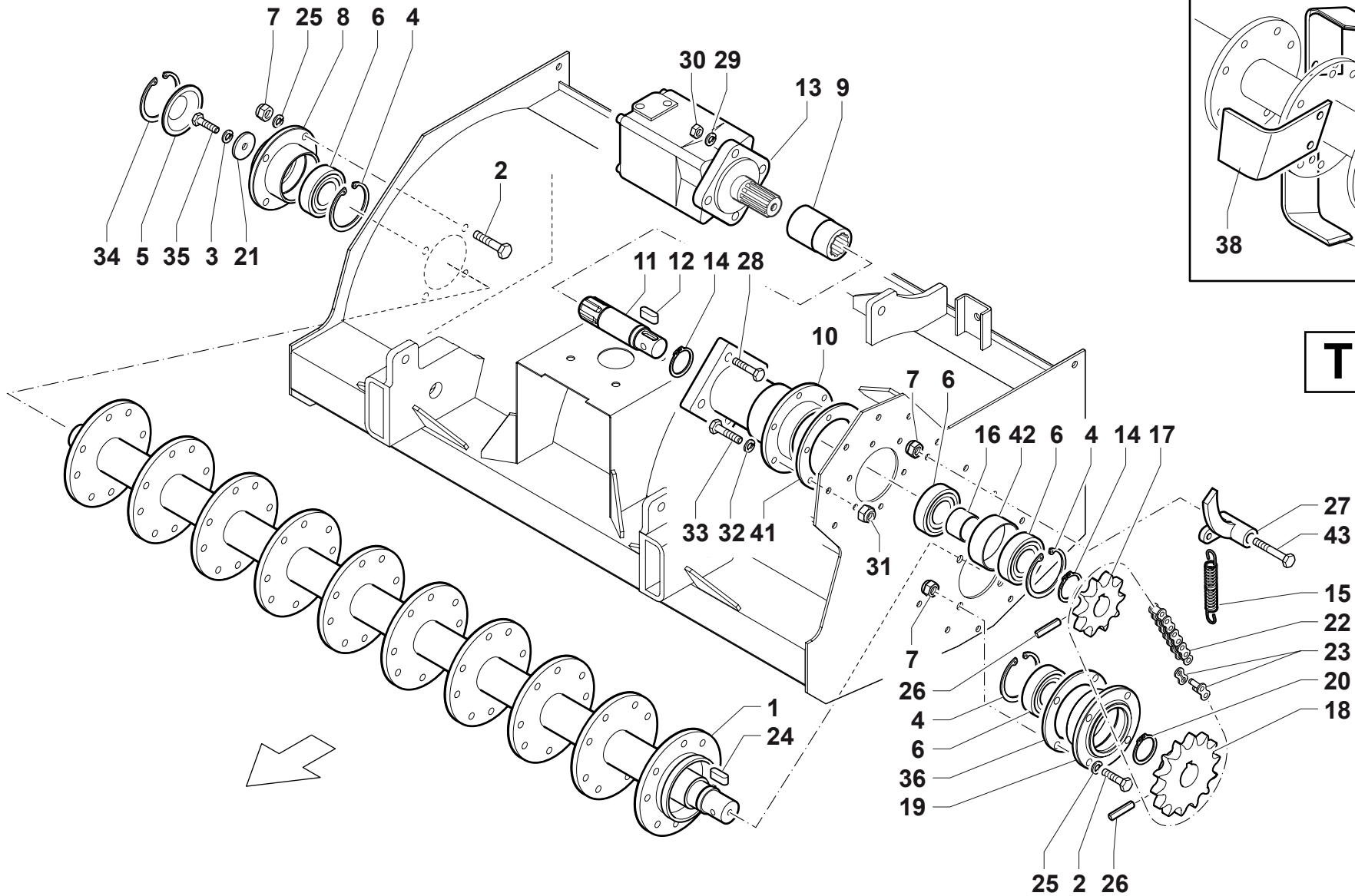

TST 130H

<i>Rif.</i>	<i>CODICE</i>	<i>Qty</i>	<i>Descrizione</i>	<i>Description</i>	<i>Designation</i>	<i>Benennung</i>	<i>Denominaciones</i>
1	060.044	1	ALBERO PORTACOLTELLI	CUTTER HOLDING SHAFT	ARBRE PORTE COUTEAUX	MESSERWELLE	ÁRBOL PORTRA CUCHILLAS
2	21.0.0.10030	8	VITE	SCREW	VIS	SCHRAUBE	TORNILLO
3	16.01.00.010	1	RONDELLA ELASTICA	SPRING WASHER	RONDELLE ELASTIQUE	FEDERSCHEIBE	ARANDELA ELASTICA
4	18.00.01.072	3	ANELLO ELASTICO	SNAP RING	ANNEAU RESSORT	SICHERUNGSRING	ANILLO ELASTICO
5	060.087	1	COPERCHIO	COVER	COUVERCLE	DECKEL	TAPA
6	A6207	4	CUSCINETTO	BEARING	PALIER	LAGERSCHALE	COJINETE
7	30.01.00.010	9	DADO AUTOBLOCCANTE	STOP NUT	ECROU DE SURETE	SPERRMUTTER	TUERCA AUTOTRABADORA
8	060.006	1	MOZZO PORTA ALBERO	SHAFT HUB	MOYEU ARBRE	WELLENNABE	CUBO EJE
9	015.012	1	MANICOTTO TRASMISSIONE	TRANSMISSION SLEEVE	MANCHON TRANSMISSION	TRANSMISSIONSROHR	MANGUITO TRANSMISIÓN
10	015.011	1	SUPPORTO	SUPPORT	SUPPORT	LAGER	SOPORTE
11	060.010	1	ALBERO DI TRASMISSIONE	PROPELLER SHAFT	ARBRE DE TRANSMISSION	WELLE TRANSMISSION	ARBOL DE TRANSMISIÓN
12	35.1.0.08030	1	LINGUETTA	KEY	CLAVETTE	KEIL	CHAVETA
13	050.045	1	MOTORE IDRAULICO	HYDRAULIC MOTOR	MOTEUR HYDRAULIQUE	HYDRAULIKMOTOR	MOTOR HIDRAULICO
14	18.01.00.035	2	ANELLO ELASTICO	SNAP RING	ANNEAU RESSORT	SICHERUNGSRING	ANILLO ELASTICO
15	050.117	1	MOLLA	SPRING	RESSORT	FEDER	RESORTE
16	031.045	1	DISTANZIALE	SPACER	ENTRETOISE	ABSTANDSTUECK	SEPARADOR
17	060.013	1	PIGNONE	PINION	PIGNON	RITZEL	PINON
18	060.014	1	CORONA	RING GEAR	COURONNE	KRANZ	CORONA
19	060.005	1	MOZZO PORTA ALBERO	SHAFT HUB	MOYEU ARBRE	WELLENNABE	CUBO EJE
20	18.01.00.040	1	ANELLO ELASTICO	SNAP RING	ANNEAU RESSORT	SICHERUNGSRING	ANILLO ELASTICO
21	15.1.0.01.010	1	RONDELLA	WASHER	RONDELLE	SCHEIBE	ARANDELA
22	050.105	1	CATENA	CHAIN	CHAÎNE	KETTE	CADENA
23	050.105/A	1	MAGLIA DI GIUNZIONE	CHAIN JOINT	JOINT DE CHAÎNE	STECKGLIED	UNIÓN DE CADENA
24	35.1.0.10030	1	LINGUETTA	KEY	CLAVETTE	KEIL	CHAVETA
25	16.01.01.010	16	RONDELLA ELASTICA	SPRING WASHER	RONDELLE ELASTIQUE	FEDERSCHEIBE	ARANDELA ELASTICA
26	38.1.1.10050	2	SPINA ELASTICA	SPLIT PIN	BROCHE ELASTIQUE	ZAPFEN FEDRIG	PERNO ELASTICO
27	060.016	1	TENDICATENA	CHAIN STRETCHER	TENDEUR DE CHAINE	KETTENSPIANN	TENJOR DE CADENA
28	22.0.1.12055	4	VITE	SCREW	VIS	SCHRAUBE	TORNILLO
29	16.01.01.012	4	GROWER	GROWER	GROWER	GROWER	GROWER
30	31.02.00.0.12	4	DADO	NUT	ECROU	MUTTER	TUERCA
31	30.03.00.008	1	DADO AUTOBLOCCANTE	STOP NUT	ECROU DE SURETE	SPERRMUTTER	TUERCA AUTOTRABADORA





CASSONETTO SEMINATRICE (SMT 100-113-130)
SEEDER BOX (SMT 100-113-130)
CAISSON SEMOIR (SMT 100-113-130)
KASTEN DRILLMASCHINE (SMT 100-113-130)
CAJA SEMBRADORA (SMT 100-113-130)

Tav. 11.0

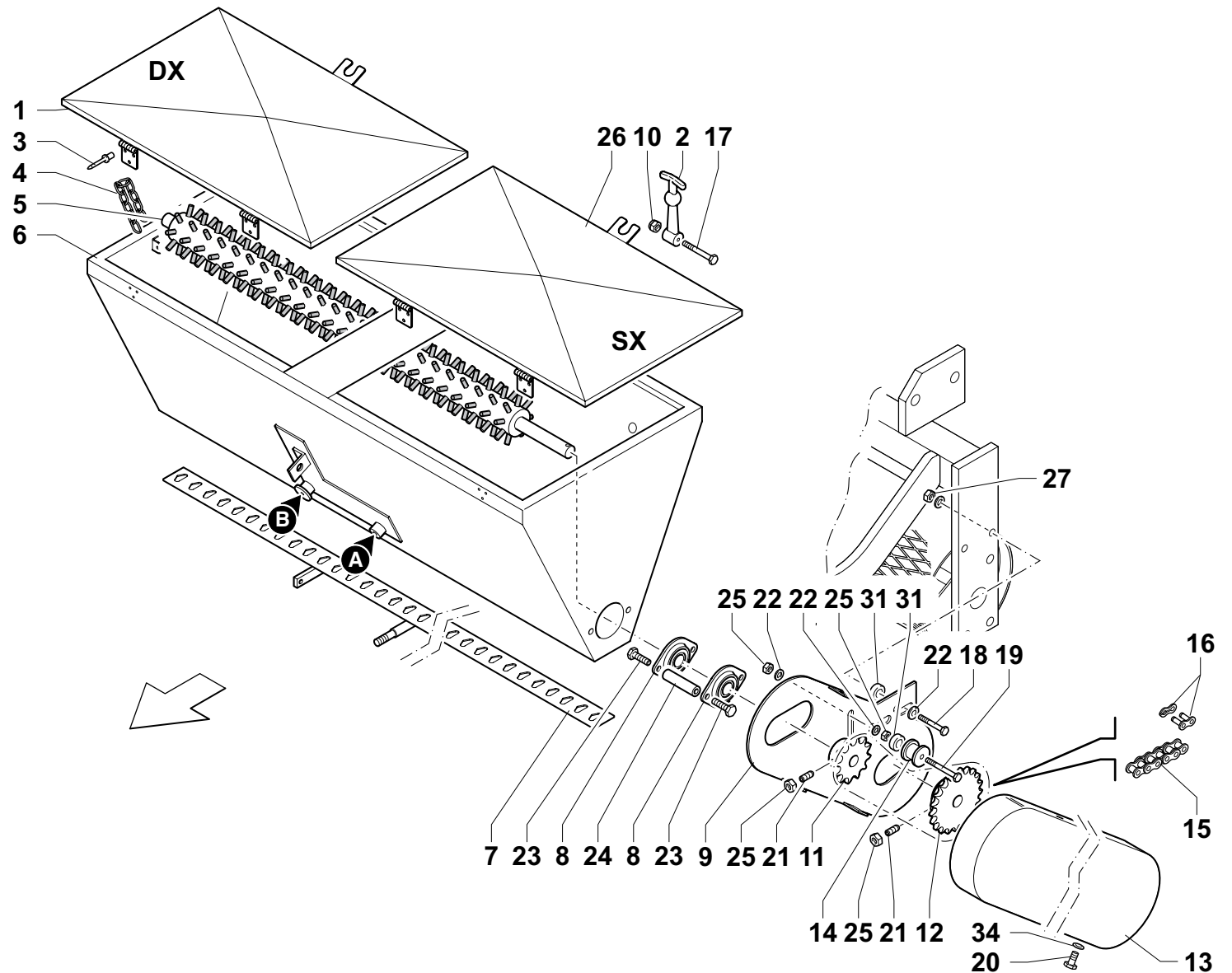
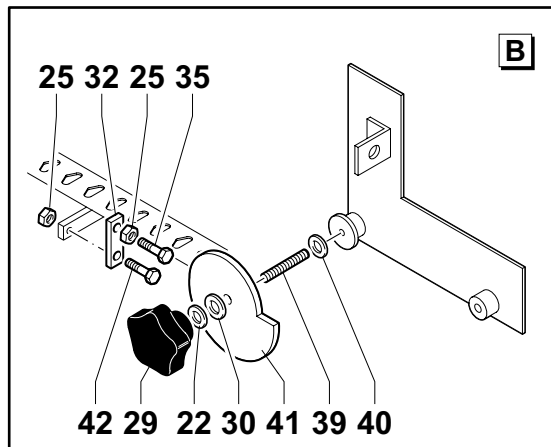
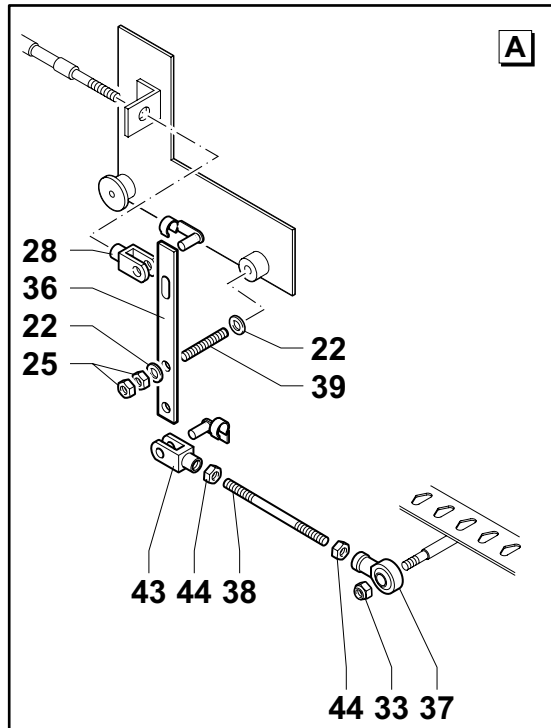

Rif.	CODICE	Qnt	Descrizione	Description	Designation	Benennung	Denominaciones
1	/DX	2	COPERCHIO SMT-100	COVER	COUVERCLE	DECKEL	TAPA
1	/DX	2	COPERCHIO SMT-113	COVER	COUVERCLE	DECKEL	TAPA
1	/DX	2	COPERCHIO SMT-130	COVER	COUVERCLE	DECKEL	TAPA
2	050.066	2	TIRANTE IN GOMMA	RUBBER TIE-ROG	TIRANT CAOUTCHOUC	GUMMI-ZUGSTANGE	TIRANTE DE GOMA
3		12	RIVETTO	RIVET	RIVET	NIETVERBINDUNG	REMACHE
4		2	CATENA	CHAIN	CHAÎNE	KETTE	CADENA
5		1	SPAZZOLA SMT-100	BOX BRUSH	BROSSE CAISSON	BÜRSTE KASTEN	CEPILLO CAJA
5		1	SPAZZOLA SMT-113	BOX BRUSH	BROSSE CAISSON	BÜRSTE KASTEN	CEPILLO CAJA
5		1	SPAZZOLA SMT-130	BOX BRUSH	BROSSE CAISSON	BÜRSTE KASTEN	CEPILLO CAJA
6		1	CASSONETTO SMT-100	SEEDER BOX	CAISSON SEMOIR	KASTEN DRILLMASCHINE	CAJA SEMBRADORA
6		1	CASSONETTO SMT-113	SEEDER BOX	CAISSON SEMOIR	KASTEN DRILLMASCHINE	CAJA SEMBRADORA
6		1	CASSONETTO SMT-130	SEEDER BOX	CAISSON SEMOIR	KASTEN DRILLMASCHINE	CAJA SEMBRADORA
7		1	BANDELLA SMT-100	BOX BAR	RABAT CAISSON	KASTENBAND	BANDA CAJA
7		1	BANDELLA SMT-113	BOX BAR	RABAT CAISSON	KASTENBAND	BANDA CAJA
7		1	BANDELLA SMT-130	BOX BAR	RABAT CAISSON	KASTENBAND	BANDA CAJA
8	BUPFL204	3	SUPPORTO	SUPPORT	SUPPORT	LAGER	SOPORTE
9	036.096/B	1	CARTER INTERNO CATENA	INTERNAL COVER FOR	CARTER INTERIEUR	INNERE SCHUTZABDECKUNG	CÁRTER INTERIOR CADENA
10	30.02.00.004	2	DADO AUTOBLOCCANTE	STOP NUT	ECROU DE SURETE	SPERRMUTTER	TUERCA AUTOTRABADORA
11	036.082	1	PIGNONE	PINION	PIGNON	RITZEL	PINON
12	036.081	1	CORONA	RING GEAR	COURONNE	KRANZ	CORONA
13	036.096/A	1	CARTER ESTERNO	EXTERNAL COVER FOR	CARTER EXTERIEUR	AUSSERE SCHUTZABDECKUNG	CÁRTER EXTERIOR CADENA
14	030.036	1	RULLO	ROLLER	ROULEAU	WALZE ROLLE	RODILLO
15	050.075	1	CATENA	CHAIN	CHAÎNE	KETTE	CADENA
16	050.076	1	MAGLIA DI GIUNZIONE	CHAIN JOINT	JOINT DE CHAÎNE	STECKGLIED	UNIÓN DE CADENA
17	21.0.0.04035	2	VITE	SCREW	VIS	SCHRAUBE	TORNILLO
18	20.0.0.08040	2	VITE	SCREW	VIS	SCHRAUBE	TORNILLO
19	20.0.0.08055	1	VITE	SCREW	VIS	SCHRAUBE	TORNILLO
20	21.0.0.05016	1	VITE	SCREW	VIS	SCHRAUBE	TORNILLO
21	25.2.1.08020	2	GRANO	SECURITY DOWEL	GRAIN	STIFT	PERNO DE TOPE
22	15.1.0.00.008	6	RONDELLA PIANA	PLAIN WASHER	RONDELLE PLANE	ABSTANDSRING	ARANDELA LLANA
23	21.0.0.08016	6	VITE	SCREW	VIS	SCHRAUBE	TORNILLO



Rif.	CODICE	Qty	Descrizione	Description	Designation	Benennung	Denominaciones
24	036.154	2	DISTANZIALE	SPACER	ENTRETOISE	ABSTANDSTUECK	SEPARADOR
25	31.02.00.0.08	8	DADO AUTOBLOCCANTE	STOP NUT	ECROU DE SURETE	SPERRMUTTER	TUERCA AUTOTRABADORA
26	/SX	2	COPERCHIO SMT-100	COVER	COUVERCLE	DECKEL	TAPA
26	/SX	2	COPERCHIO SMT-113	COVER	COUVERCLE	DECKEL	TAPA
26	/SX	2	COPERCHIO SMT-130	COVER	COUVERCLE	DECKEL	TAPA
27	30.02.00.008	2	DADO AUTOBLOCCANTE	STOP NUT	ECROU DE SURETE	SPERRMUTTER	TUERCA AUTOTRABADORA
28	050.070	1	FORCELLA	FORK	FOURCHE	GABEL	HORQUILLA
29	050.030	1	POMELLO	BALL-GRIP	POMMEAU	KUGELGRIFF	POMO
30	050.071	1	RONDELLA TEFLON	TEFLON WASHER	RONDELLE TEFLON	TEFLON-SCHEIBE	ARANDELA TEFLON
31	036.205	1	DISTANZIALE	SPACER	ENTRETOISE	ABSTANDSTUECK	SEPARADOR
32	036.068	1	LEVA	LEVER	LEVIER	HEBEL	PALANCA
33	30.02.01.008	1	DADO AUTOBLOCCANTE	STOP NUT	ECROU DE SURETE	SPERRMUTTER	TUERCA AUTOTRABADORA
34	15.0.0.00.005	1	RONDELLA PIANA	PLAIN WASHER	RONDELLE PLANE	ABSTANDSRING	ARANDELA LLANA
35	20.0.0.08035	1	VITE	SCREW	VIS	SCHRAUBE	TORNILLO
36	036.064	1	LEVA	LEVER	LEVIER	HEBEL	PALANCA
37	050.263	1	SNODO SFERICO	BALL JOINT	JOINT A ROTULE	KUGELGELENK	ARTICULACION DE BOLA
38	045.041	1	BARRA FILETTATA	THREADED BAR	BARE FILETEE	STANGE SCHRAUBEN	BARRA FILETEAR
39	26.0.0.08025	2	PRIGIONIERO	STUD	PRISONNIER	GEWINDESTIFT	PRISIONERO
40	050.072	1	RONDELLA PIANA	PLAIN WASHER	RONDELLE PLANE	ABSTANDSRING	ARANDELA LLANA
41	036.066	1	CAMMA REGOLAZIONE	ADJUSTMENT CAM	CAME DE REGLAGE	EINSTELNOCCKEN	LEVA DE AJUSTE
42	21.0.0.08025	1	VITE	SCREW	VIS	SCHRAUBE	TORNILLO
43	050.069	2	FORCELLA	FORK	FOURCHE	GABEL	HORQUILLA
44	31.02.00.008	4	DADO	NUT	ECROU	MUTTER	TUERCA



<i>Rif.</i>	<i>CODICE</i>	<i>Qty</i>	<i>Descrizione</i>	<i>Description</i>	<i>Designation</i>	<i>Benennung</i>	<i>Denominaciones</i>
1	15.1.0.00.010	2	RONDELLA PIANA	PLAIN WASHER	RONDELLE PLANE	ABSTANDSRING	ARANDELA LLANA
2	15.1.0.00.012	8	RONDELLA PIANA	PLAIN WASHER	RONDELLE PLANE	ABSTANDSRING	ARANDELA LLANA
3	060.030	1	REGISTRO	ADJUSTER	REGLAGE	REGULATOR	AJUSTE
4	036.109	1	SUPPORTO RULLO SMT-113	SUPPORT	SUPPORT	LAGER	SOPORTE
4	036.118	1	SUPPORTO RULLO SMT-100	SUPPORT	SUPPORT	LAGER	SOPORTE
4	036.194	1	SUPPORTO RULLO SMT-130	SUPPORT	SUPPORT	LAGER	SOPORTE
5	UCFL204	2	SUPPORTO	SUPPORT	SUPPORT	LAGER	SOPORTE
6	036.117	1	RUSPETTA SMT-113	LEVELLING BAR	BARRE NIVELEUSE	PLANIERSTANGE	BARRA NIVELADORA
6	036.120	1	RUSPETTA SMT-100	LEVELLING BAR	BARRE NIVELEUSE	PLANIERSTANGE	BARRA NIVELADORA
6	036.196	1	RUSPETTA SMT-130	LEVELLING BAR	BARRE NIVELEUSE	PLANIERSTANGE	BARRA NIVELADORA
7	036.080/D	1	SUPPORTO CASSONETTO DX	RIGHT BOX SUPPORT	SUPPORT COFFRE DROIT	KASTENHALTERUNG RECHTS	SOPORTE CAJA DERECHA
8	036.080/S	1	SUPPORTO CASSONETTO SX	LEFT BOX SUPPORT	SUPPORT COFFRE GAUCHE	KASTENHALTERUNG LINKS	SOPORTE CAJA IZQUIERDA
9	036.037	1	SUPPORTO SPAZZOLA SMT-130	BRUSH SUPPORT	SUPPORT BROSSE	BÜRSTENTRÄGER	SOPORTE CEPILLO
9	036.123	1	SUPPORTO SPAZZOLA SMT-100	BRUSH SUPPORT	SUPPORT BROSSE	BÜRSTENTRÄGER	SOPORTE CEPILLO
9	036.179	1	SUPPORTO SPAZZOLA SMT-113	BRUSH SUPPORT	SUPPORT BROSSE	BÜRSTENTRÄGER	SOPORTE CEPILLO
10	036.049	1	SPAZZOLA SMT-100	BRUSH	BROSSE	BUERSTE	CEPILLO
10	036.050	1	SPAZZOLA SMT-113	BRUSH	BROSSE	BUERSTE	CEPILLO
10	236.189	1	SPAZZOLA SMT-130	BRUSH	BROSSE	BUERSTE	CEPILLO
11	036.024	1	RULLO SMT-130	ROLLER	ROULEAU	WALZE ROLLE	RODILLO
11	036.026	1	RULLO SMT-113	ROLLER	ROULEAU	WALZE ROLLE	RODILLO
11	036.121	1	RULLO SMT-100	ROLLER	ROULEAU	WALZE ROLLE	RODILLO
12	21.0.0.10045	4	VITE	SCREW	VIS	SCHRAUBE	TORNILLO
13	000.001	2	FRULLETTO	THREADED PIN	AXE TARAUDE	GEWINDEBOLZEN	PERNO CON ROSCA
14	20.0.0.10035	4	VITE	SCREW	VIS	SCHRAUBE	TORNILLO
15	21.0.0.08030	4	VITE	SCREW	VIS	SCHRAUBE	TORNILLO
16	21.0.0.06020	-	VITE	SCREW	VIS	SCHRAUBE	TORNILLO
17	20.0.5.12040	4	VITE	SCREW	VIS	SCHRAUBE	TORNILLO
18	036.086	6	PIATTO	PLATE	PLATEAU	TELLER	DISCO
19	30.02.00.010	8	DADO AUTOBLOCCANTE	STOP NUT	ECROU DE SURETE	SPERRMUTTER	TUERCA AUTOTRABADORA
20	30.02.01.012	10	DADO AUTOBLOCCANTE	STOP NUT	ECROU DE SURETE	SPERRMUTTER	TUERCA AUTOTRABADORA
21	036.119	1	SCIVOLO PER SEME SMT-100	SEED CHUTE	GLISSOIR SEMENCES	KÖRNERRUTSCHE	RAMPA SEMILLAS



