

Planche N°1

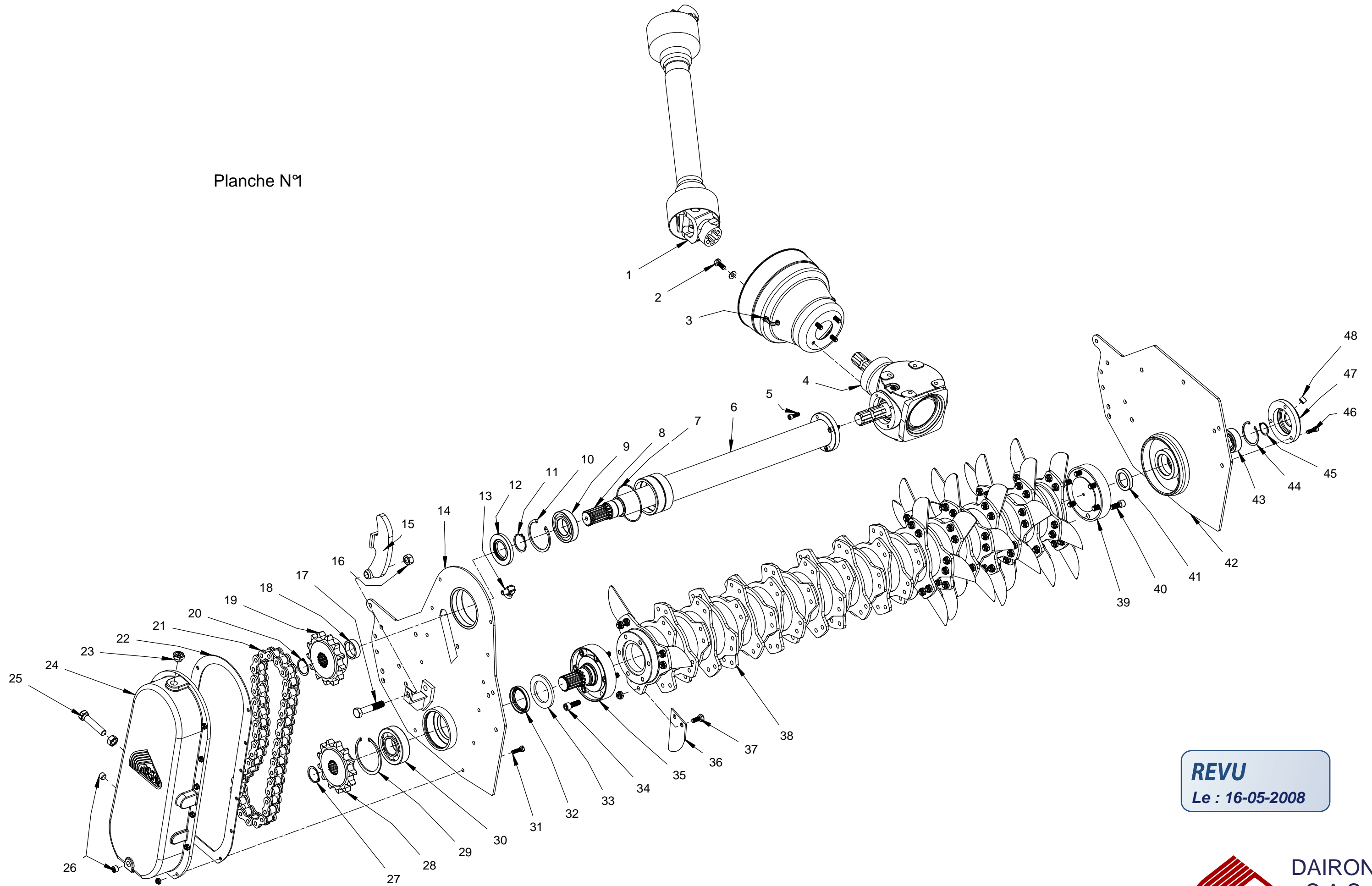

REVU
Le : 16-05-2008

PARTIE TRANSMISSION CR 140 / 200



DAIRON S.A.S. D92 Les Hunaudières
72230 MULSANNE
☎ 02 43 422 422 Fax. 02 43 422 000
E-mail. Rotadairon@wanadoo.fr

REVU

Le : 16-05-2008

Planche N°2

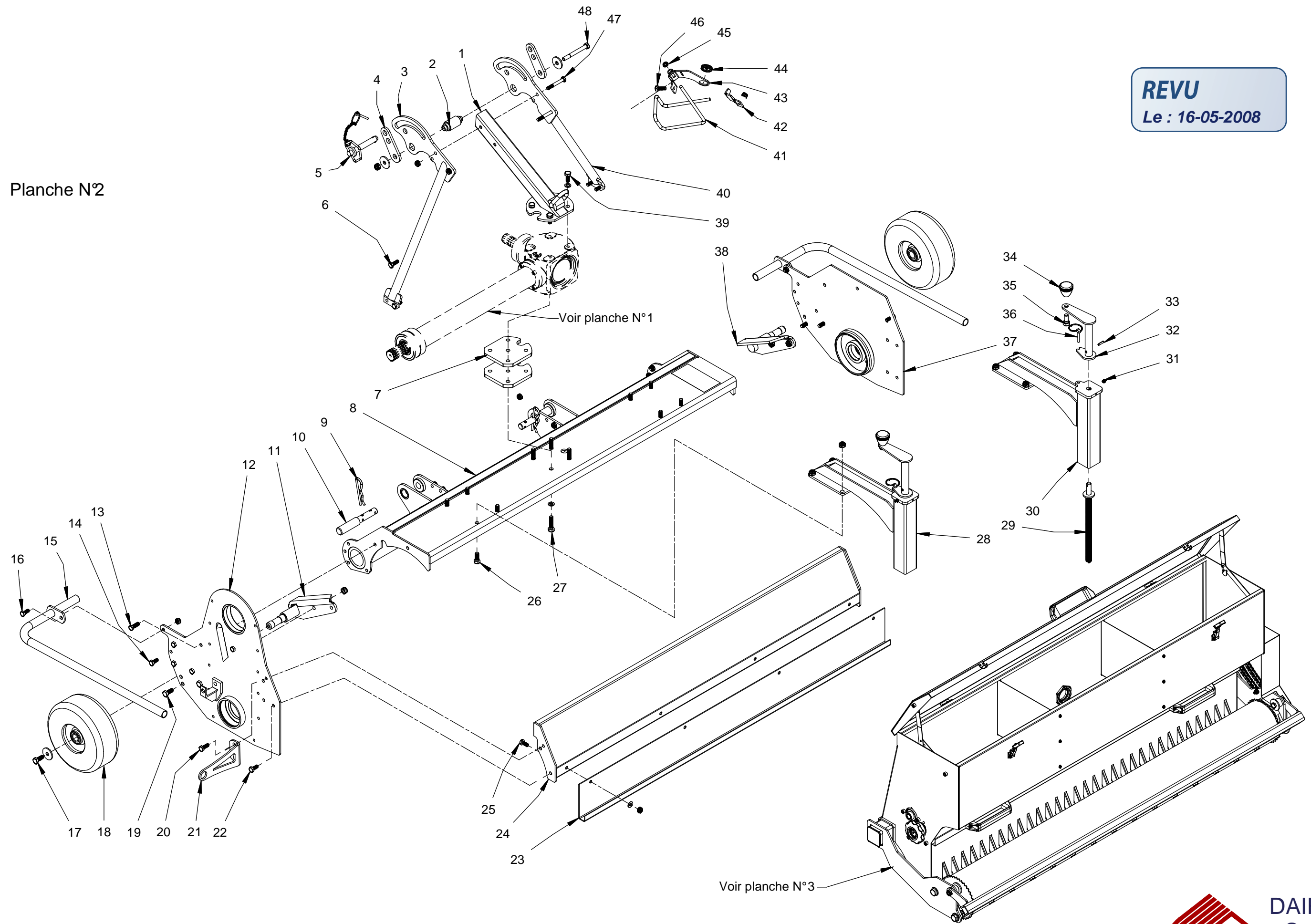

PARTIE AVANT CR 140 / 200



DAIRON
S.A.S

Since 1958

DAIRON S.A.S. D92 Les Hunaudières
72230 MULSANNE

☎ 02 43 422 422 Fax. 02 43 422 000
E-mail. Rotadairon@wanadoo.fr

Planche N°3

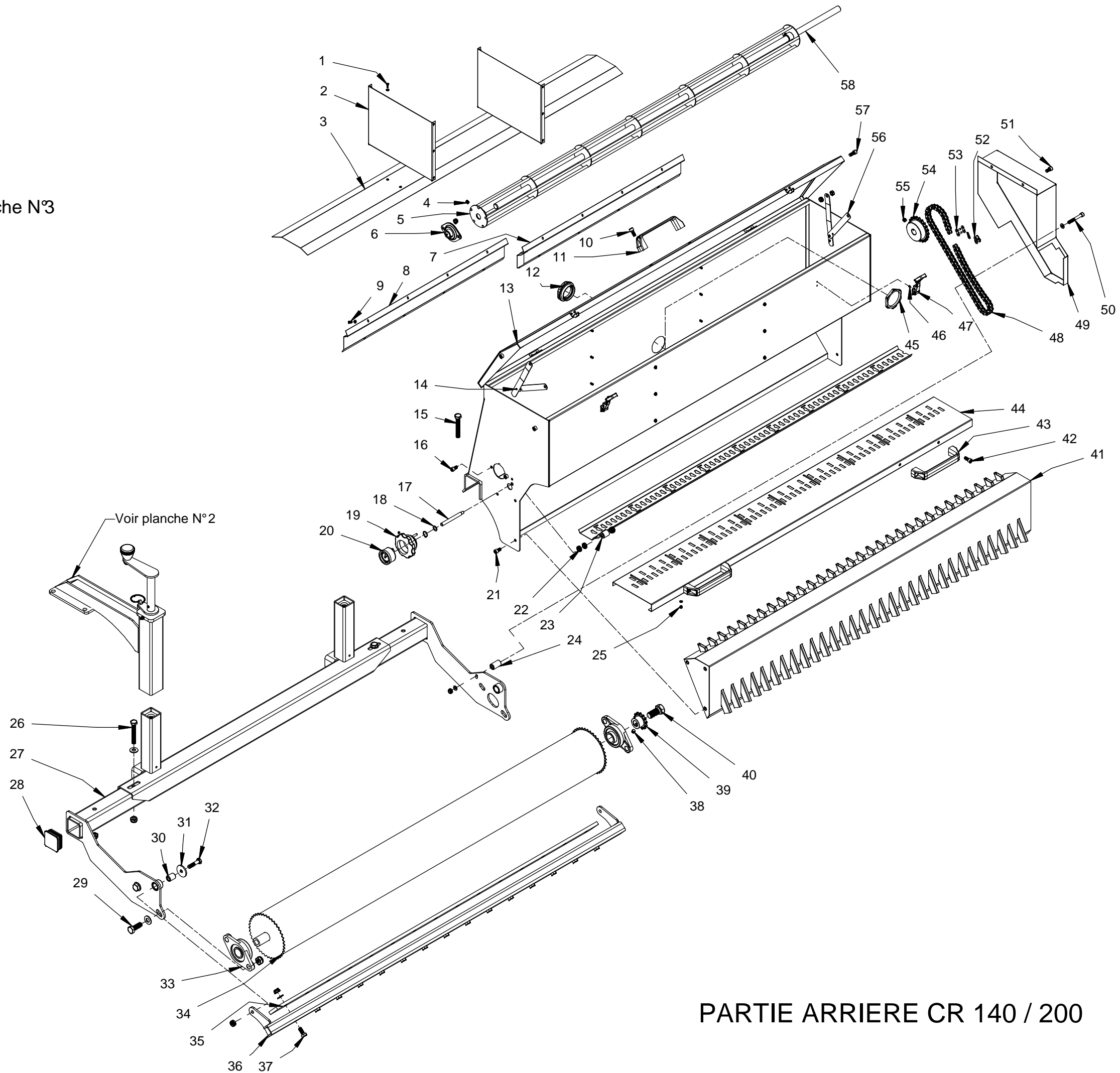

PARTIE ARRIERE CR 140 / 200

REVVU
Le : 16-05-2008



DAIRON S.A.S
Since 1958
DAIRON S.A.S. D92 Les Hunaudières
72230 MULSANNE
☎ 02 43 422 422 Fax. 02 43 422 000
E-mail. Rotadairon@wanadoo.fr

NOMENCLATURE PLANCHE N° CR 140 +5634 / CR 200 +6596 16-05-2008

REP	DESIGNATION	REFERENCES PIECES			
		CR 140	QTE	CR 200	QTE
1	TRANSMISSION	094-1010	1	094-1010	1
2	VIS H,10x25,8.8,DIN 933 ZBJ	850-2003	4	850-2003	4
	RONDELLE MU 10 ZBJ	695-1017	4	695-1017	4
3	CACHE VOLANT	093-1005	1	093-1005	1
4	BOITIER RENVOI D'ANGLE	095-1003	1	095-1003	1
5	VIS C HC 8 * 25 CL 8.8	850-3003	4	850-3003	4
6	TROMPETTE	3140-760-1047	1	3200-760-1095	1
7	JOINT OR 95 x 2.5	400-1008	1	400-1008	1
8	ARBRE SECONDAIRE	3140-100-1007	1	3200-100-1048	1
9	ROULEMENT 6209	690-1011	1	690-1011	1
10	CIRCLIPS 85 INT	190-1007	1	190-1007	1
11	CIRCLIPS 45 EXT	190-1003	1	190-1003	1
12	JOINT A LEVRE 45x85x10 D.L.	400-1001	1	400-1001	1
13	EQUERRE G13-8x13	265-1002	1	265-1002	1
14	COTE GAUCHE	3140-195-1006	1	3140-195-1006	1
15	TENDEUR DE CHAINE	3140-730-1006	1	3140-730-1006	1
16	ECROU M16-4032	260-1016	1	260-1016	1
17	VIS H 16 * 80 CL 8.8	850-1015	1	850-1015	1
18	BAGUE ENTRETOISE	139-1002	1	139-1002	1
19	PIGNON DE CHAINE 13D	600-1001	1	600-1001	1
20	CIRCLIPS 40 EXT	190-1001	1	190-1001	1
21	CHAINE PAS 31.75	175-1001	1	175-1001	1
22	JOINT LIEGE	420-1003	1	420-1003	1
23	BOUCHON DE REMPLISSAGE TCC	155-1003	1	155-1003	1
24	CARTER DE CHAINE	180-1006	1	180-1006	1
25	VIS H, M16 x 80,CL 8.8 - DIN 933	850-2011	1	850-2011	1
	ECROU M16, ZBJ, 4032	260-1015	1	260-1015	1
26	BOUCHON HC 3/8 G	155-1001	2	155-1001	2
27	CIRCLIPS 40 EXT	190-1001	1	190-1001	1
28	PIGNON 13 DENTS PAS 31.75	600-1020	1	600-1020	1
29	CIRCLIPS Ø100 INT.	190-1006	1	190-1006	1
30	ROULEMENT 6309 C3	690-1003	1	690-1003	1
31	VIS H 8 * 30 CL 8.8	850-2021	12	850-2021	12
	ECROU M8, ZBJ, DIN 985	260-1010	12	260-1010	12
32	JOINT SPI 54.72.10 D.L	400-1005	1	400-1005	1
33	JOINT FEUTRE Ø60/Ø90x6	415-1001	1	415-1001	1
34	VIS C HC M12 * 35 CL 12.9	850-3015	6	850-3015	6
35	PLATEAU D'ENTRAINEMENT	3140-630-1010	1	3140-630-1010	1
36	LAME	450-1017	93	450-1017	123

NOMENCLATURE PLANCHE N°1 CR 140 +5634 / CR 200 +6596 16-05-2008

REP	DESIGNATION	REFERENCES PIECES			
		CR 140	QTE	CR 200	QTE
37	VIS H 10 * 25 CL 10.9	850-1038	186	850-1038	246
	ECROU H, M10 - DIN 985 - ZBJ	260-1011	186	260-1011	246
38	ROTOR	3140-760-1084	1	3200-760-1085	1
39	PETIT PLATEAU	5150-630-1003	1	5150-630-1003	1
40	VIS C HC 12 * 30 CL 12.9	850-3019	6	850-3019	6
41	JOINT SPI 40,58,10 DL	400-1002	1	400-1002	1
42	COTE DROIT	3140-195-1007	1	3140-195-1007	1
43	ROULEMENT 22206	690-1017	1	690-1017	1
44	CIRCLIPS 62 INT	190-1016	1	190-1016	1
45	CIRCLIPS 30 EXT	190-1002	1	190-1002	1
46	VIS C HC 8 * 25 CL 8.8	850-3003	3	850-3003	3
47	CHAPEAU FTE 74	178-1004	1	178-1004	1
48	BOUCHON HC 3/8 G	155-1001	1	155-1001	1

NOMENCLATURE PLANCHE N°2 CR 140 +5634 / CR 200 +6596

16-05-2008

REP	DESIGNATION	REFERENCES PIECES			
		CR 140	QTE	CR 200	QTE
1	ATTELAGE 3 IEME POINT	3140-750-1041	1	3140-750-1041	1
2	DOUILLE ENTRETOISE ATTELAGE	240-1102	1	240-1102	1
3	TIRANT GAUCHE	3140-760-G032	1	3140-760-G032	1
4	PLAT D'OSCILLATION	640-1277	2	640-1277	2
5	BROCHE	151-1002	1	151-1002	1
6	VIS H 10 * 30 CL 8.8	850-1012	4	850-1012	4
	ECROU H, M10 - DIN 985	260-1011	4	260-1011	4
7	PLAQUE ENTRETOISE	640-1217	2	640-1217	2
8	CAPOT	3140-770-1048	1	3200-770-1114	1
9	GOUPILLE BETA Ø6	340-1001	2	340-1001	2
10	AXE DOUBLE 22 x 28	120-1006	2	120-1006	2
11	SUPPORT DE ROUE GAUCHE	3140-720-1045	1	3140-720-1045	1
12	COTE GAUCHE	3140-195-1006	1	3140-195-1006	1
13	VIS H 7/16 NF 1" 1/4 CL 12.9	850-1001	4	850-1001	4
	ECROU HH -7/16 UNF	260-1001	4	260-1001	4
14	VIS H,10 * 25,CL 8.8	850-1011	8	850-1011	8
	ECROU H, M10 - DIN 985	260-1011	8	260-1011	8
15	CANNE DE PROTECTION	5075-760-1204	2	5075-760-1204	2
16	VIS H,10 x 25,CL 8.8	850-2003	2	850-2003	2
	ECROU H, M10 - DIN 985	260-1011	2	260-1011	2
17	VIS H, M12 * 30, CL 8.8	850-2016	2	850-2016	2
	RONDELLE Ø13 x Ø42 x 4	695-1027	2	695-1027	2
18	ROUE	685-1003	2	685-1003	2
19	VIS H, M12 - 30, CL 8.8	850-2016	4	850-2016	4
	ECROU H, M12 - DIN 985	260-1012	4	260-1012	4
20	VIS H,10 * 30,CL 8.8	850-2002	2	850-2002	2
	ECROU H, M10 - DIN 985	260-1011	2	260-1011	2
21	PATTE ENTRETOISE DE CANNE	620-1144	2	620-1144	2
22	VIS H,10 x 25,CL 8.8	850-2003	2	850-2003	2
	ECROU H, M10 - DIN 985	260-1011	2	260-1011	2
23	TÔLE VOLET BASSE	770-1213	1	770-1214	1
24	VOLET ARRIERE	3140-770-1050	1	314-770-1116	1
25	VIS H,10 * 25, CL 8.8	850-2003	4	850-2003	5
	RONDELLE MU 10	695-1017	4	695-1017	5
	ECROU H, M10 - DIN 985	260-1011	4	260-1011	5
26	VIS H, M12 * 30, CL 8.8	850-1014	8	850-1014	8
	ECROU H, M12 - DIN 985	260-1012	8	260-1012	8
27	VIS H, M12 * 50, CL 8.8	850-2012	4	850-2012	4
	RONDELLE W12	695-1019	4	695-1019	4
28	BRAS GAUCHE DE CHASSIS	3140-270-G017	1	3140-270-G017	1
29	VIS DE MANIVELLE	5180-850-1043	2	5180-850-1043	2

NOMENCLATURE PLANCHE N°2 CR 140 +5634 / CR 200 +6596

16-05-2008

REP	DESIGNATION	REFERENCES PIECES			
		CR 140	QTE	CR 200	QTE
30	BRAS DROIT DE CHASSIS	3140-270-D017	1	3140-270-D017	1
31	GRAISSEUR	320-1001	2	320-1001	2
32	MANIVELLE	3140-640-1001	2	3140-640-1001	2
33	GOUPILLE MECANINDUS Ø6x25	340-1007	2	340-1007	2
34	POIGNEE DE MANIVELLE Ø14	610-1001	2	610-1001	2
35	VIS H, M14 * 30, CI 8.8	850-2005	2	850-2005	2
36	GOUPILLE CLIPS Ø6	340-1005	2	340-1005	2
37	COTE DROIT	3140-195-1007	1	3140-195-1007	1
38	SUPPORT DE ROUE DROIT	3140-720-1008	1	3140-720-1008	1
39	VIS H, M12 * 30, CL 8.8	850-1014	4	850-1014	4
	RONDELLE W12	695-1019	4	695-1019	4
40	TIRAND DROIT	3140-760-D032	1	3140-760-D032	1
41	FIL SUPPORT PDF	620-1099	1	620-1099	1
42	PLAQUE DE FERMETURE PINCE	640-1299	1	640-1299	1
43	PINCE POUR SUPPORT PDF	3130-640-1300	1	3130-640-1300	1
44	BOUCHON ODTURATEUR	156-1009	1	156-1009	1
45	ANNEAU D'ARRET Ø10	190-1025	1	190-1025	1
46	VIS H,10 * 30,CL 8.8	850-2002	1	850-2002	1
	ECROU H, M10 - DIN 985	260-1011	1	260-1011	1
47	VIS H 10 * 75 CL 8.8	850-2030	2	850-2030	2
	ECROU H, M10 - DIN 985	260-1011	2	260-1011	2
48	VIS H, M12 * 110, CI 8.8	850-2048	1	850-2048	1
	RONDELLE Ø13 x Ø42 x 4	695-1027	2	695-1027	2
	ECROU H, M12 - DIN 985	260-1012	1	260-1012	1

NOMENCLATURE PLANCHE N°3 CR 140 +5634 / CR 200 +6596

16-05-2008

REP	DESIGNATION	REFERENCES PIECES			
		CR 140	QTE	CR 200	QTE
1	VIS H 4 * 12 CL 8.8 INOX	850-4004	16	850-4004	24
	RONDELLE MU,4 INOX	695-4001	16	695-4001	24
2	PLAQUE RENFORT DE CUVE	5150-770-1320	2	5150-770-1320	3
3	DEFLECTEUR	5150-770-1326	1	6205-770-1334	1
4	VIS HC 8 * 10 INOX	850-4001	2	850-4001	2
5	MALAXEUR	5150-280-1113	1	6205-280-1113	1
6	PALIER SLFL Ø20	690-1022	2	690-1022	2
7	GUIDE AVANT DROIT	3140-770-1321	1	3200-770-1336	1
8	GUIDE AVANT GAUCHE	770-1322	1	770-1337	1
9	VIS H 4 * 12 CL 8.8 INOX	850-4004	16	850-4004	20
	RONDELLE MU,4 INOX	695-4001	16	695-4001	20
10	VIS C HC 8 * 20 CL 8.8	850-4006	2	850-4006	4
	ECROU M8, DIN 985 INOX	260-4005	2	260-4005	4
11	POIGNEE M443/200 N CH	610-1003	1	610-1003	2
12	BOUCHON 3/5 FGH 40/52	155-1006	1	155-1006	1
13	CUVE	715-1011	1	715-1012	1
14	COMPAS GAUCHE	900-1006	1	900-1006	1
15	VIS H 12 * 80 CL 8.8	850-2014	2	850-2014	2
	ECROU H, M12 - DIN 985	260-1012	2	260-1012	2
16	VIS C HC 8 * 16 CL 8.8 INOX	850-4005	4	850-4005	4
	ECROU M8, DIN 985 INOX	260-4005	4	260-4005	4
17	AXE DE REGLAGE DEBIT	120-1069	1	120-1069	1
18	RONDELLE LAITON 18 x 10.5 x 0.8	695-1011	2	695-1011	2
19	VOLANT A LOBES VHT85	800-1005	1	800-1005	1
20	CADRAN INDICATEUR PA 11.12	159-1001	1	159-1001	1
21	VIS C HC 8 * 16 CL 8.8 INOX	850-4005	6	850-4005	6
22	ECROU HM,10 INOX	260-4001	4	260-4001	4
23	REGLETTE	3140-655-1004	1	3200-655-1005	1
24	DOUILLE	240-1051	1	240-1051	1
25	ECROU M4,INOX,DIN985	260-4003	16	260-4003	24
	RONDELLE MU,4 INOX	695-4001	18	695-4001	24
26	VIS H 12 * 80 CL 8.8	850-2014	2	850-2014	2
	ECROU H, M12 - DIN 985	260-1012	2	260-1012	2
27	CHASSIS	3140-750-1160	1	3200-750-1162	1
28	BOUCHON PLASTIQUE	156-1002	2	156-1002	2
29	VIS H 14 * 40 CL 8.8	850-2006	4	850-2006	4
	RONDELLE MU 14	695-1026	4	695-1026	4
	ECROU H, M14 - DIN 985	260-1013	4	260-1013	4
30	DOUILLE	240-1022	2	240-1022	2
31	RONDELLE	695-1029	2	695-1029	2
32	VIS H 10 * 40 CL 8.8	850-2008	2	850-2008	2
	ECROU H, M10 - DIN 985	260-1011	2	260-1011	2
33	PALIER UCFL 206	690-1021	2	690-1021	2
34	ROULEAU INOX	3140-760-1019	1	3200-760-1096	1
35	GRATTOIR	645-1002	1	645-1004	1
36	SUPPORT GRATTOIR	3140-770-1060	1	3200-770-1117	1

NOMENCLATURE PLANCHE N°3 CR 140 +5634 / CR 200 +6596

16-05-2008

REP	DESIGNATION	REFERENCES PIECES			
		CR 140	QTE	CR 200	QTE
37	VIS H,10 x 25,CL 8.8	850-2003	15	850-2003	20
	RONDELLE MU 10	695-1017	15	695-1017	20
	ECROU H, M10 - DIN 985	260-1011	15	260-1011	20
38	VIS HC 10 x 10 INOX	850-4002	1	850-4002	1
39	PIGNON	600-1030	1	600-1030	1
40	VIS H 20 * 45 CL 8.8	850-2044	1	850-2044	1
41	DISTRIBUTEUR DE GRAINE	3140-770-1324	1	3200-770-1338	1
42	VIS C HC 8 * 20 CL 8.8	850-4006	2	850-4006	4
	ECROU M8, DIN 985 INOX	260-4005	2	260-4005	4
43	POIGNEE M443/200 N CH	610-1003	1	610-1003	2
44	TIROIR	770-1319	1	770-1331	1
45	ECROU GHIERRA 2. HGH 40	260-1009	1	260-1009	1
46	RIVET Ø3 X 10	697-1002	8	697-1002	8
47	FERMETURE SE SEMOIR	900-1001	2	900-1001	2
48	CHAINE 67 MAILLONS SPAS 12.7	175-1007	1	175-1007	1
49	CARTER DE CHAINE	180-1012	1	180-1012	1
50	VIS C HC 8 * 50 INOX	850-4009	1	850-4009	1
	RONDELLE MU 8, ZC	695-1062	2	695-1062	2
	ECROU M8, DIN 985 INOX	260-4005	1	260-4005	1
51	VIS C HC 8 * 16 CL 8.8 INOX	850-4005	2	850-4005	2
	ECROU M8, DIN 985 INOX	260-4005	2	260-4005	2
52	MAILLON COUDE	175-1008	1	175-1008	1
53	ATTACHE RAPIDE	175-1009	1	175-1009	1
54	PIGNON	600-1029	1	600-1029	1
55	VIS HC 10 x 10 INOX	850-4002	1	850-4002	1
56	COMPAS DROIT	900-1005	1	900-1005	1
57	VIS C HC 8 * 20 CL 8.8	850-4006	4	850-4006	4
	ECROU M8 INOX , 4032	260-4004	4	850-4004	4
	ECROU M8, DIN 985 INOX	260-4005	4	260-4005	4
58	AXE DE MALAXEUR	120-1022	1	120-1025	1