

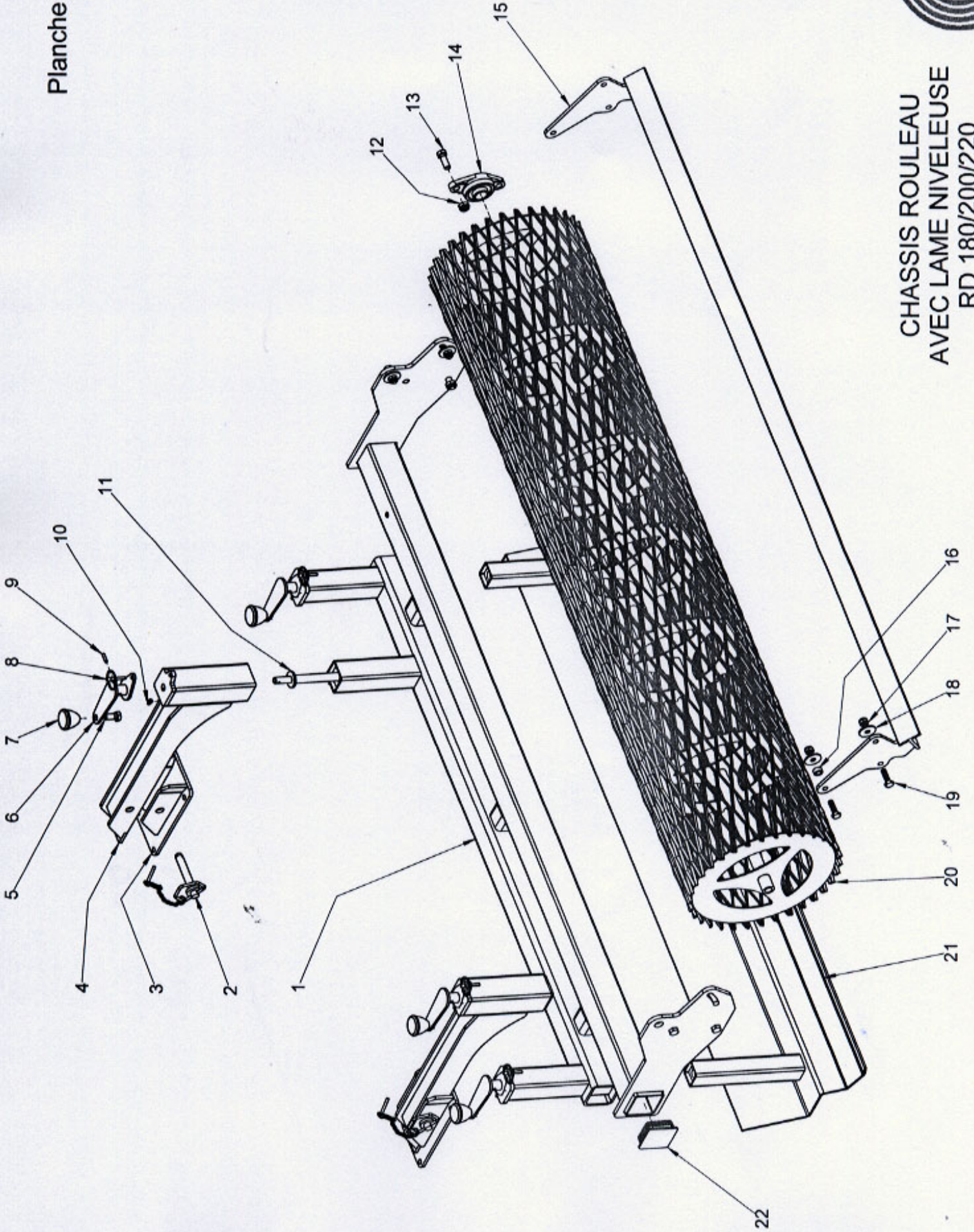

CHASSIS ROULEAU
AVEC LAME NIVELEUSE
RD 180/200/220

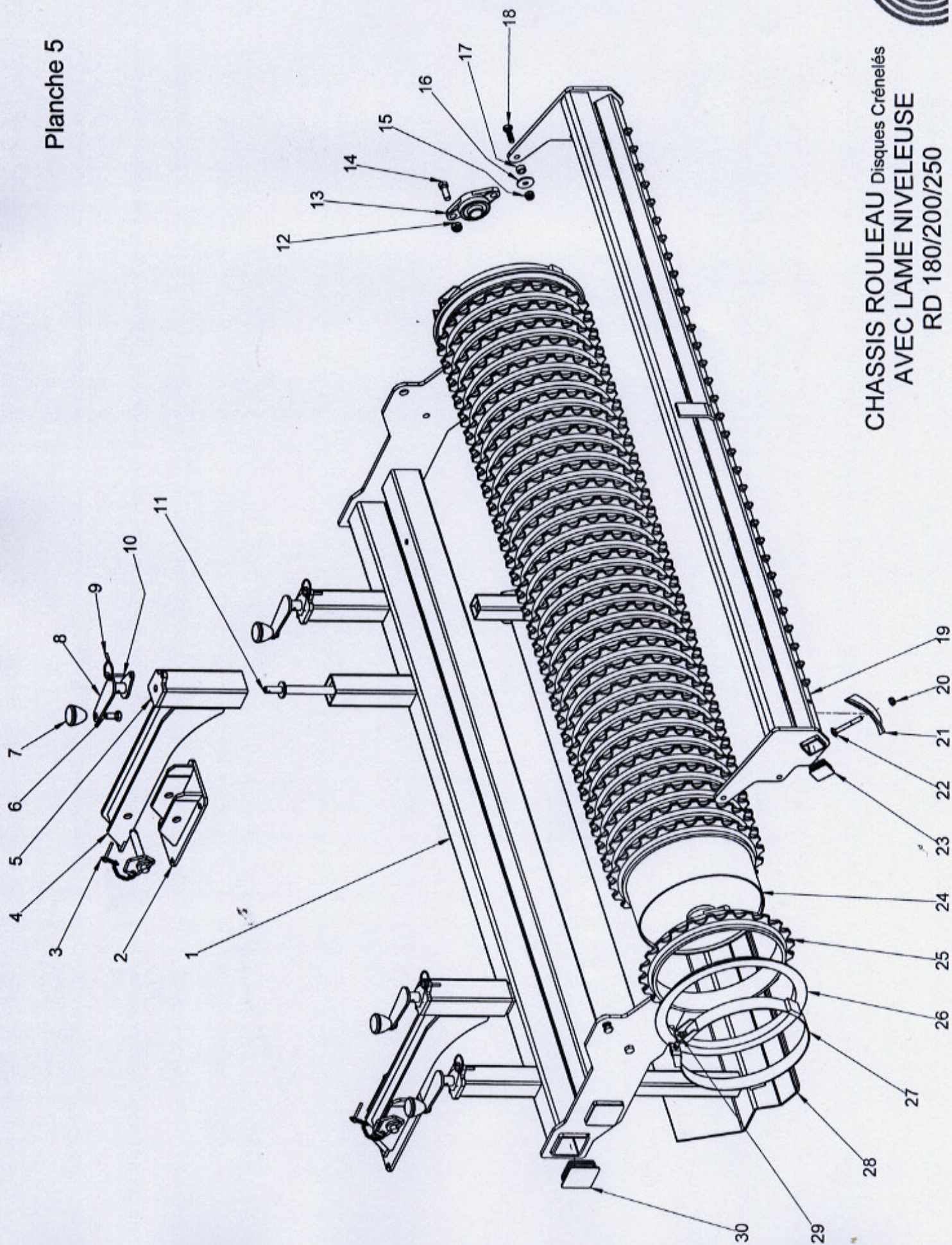



CHASSIS ROULEAU Disques Crénelés
AVEC LAME NIVELEUSE
RD 180/200/250

SPARE PARTS LIST 2004 DRAWING NR 1 RD 180 / 200 / 250

1/2

NR	DESIGNATIONS	SPARE PARTS REFERENCES					
		RD 180	QTY	RD 200	QTY	RD 250	QTY
1	CHAIN CASE RD150/180/200	180.1003.	1	180.1003.	1	180.1003.	1
2	CORK GASKET FOR CHAIN CASE	420.1002.	1	420.1002.	1	420.1002.	1
3	CAP TCD 1/2	155.1003.	1	155.1003.	1	155.1003.	1
4	CHAIN 38 CHAIN LINKS PAS 38.1	175.1002.	1	175.1002.	1	175.1002.	1
5	CIRCLIPS 45 EXT	190.1003.	1	190.1003.	1	190.1003.	1
6	PITCH CHAIN WHEEL 10 TEETH	600.1008.	1	600.1008.	1	600.1008.	1
7	BOLT H, M16-90	4000.1039.	1	4000.1039.	1	4000.1039.	1
8	BOLT H, M8-35	4000.005.	14	4000.005.	14	4000.005.	14
9	BREATHER G13 8 x 13 ZBJ	265.1002.	1	265.1002.	1	265.1002.	1
10	SPACER Ø45x55x19	139.1005.	1	139.1005.	1	139.1005.	1
11	PAPER GASKET 160	415.1002.	1	415.1002.	1	415.1002.	1
12	BOLT H, M12-35	4000.1018.	12	4000.1018.	12	4000.1018.	12
13	BOLT H, M12-130	4000.1022.	6	4000.1022.	6	4000.1022.	6
14	CLUTCH SPRING 8.31.32 ZBJ	660.1004.	6	660.1004.	6	660.1004.	6
15	BALL BEARING 6305 EE	690.1006.	1	690.1006.	1	690.1006.	1
16	FRONT WHEEL 302.55	800.1002.	1	800.1002.	1	800.1002.	1
17	PEG 6x40	340.1009.	1	340.1009.	1	340.1009.	1
18	NUT Hm 30 x 200 G	260.1007.	1	260.1007.	1	260.1007.	1
19	CLUTCH DISC 257	5150.257.1001.	1	5150.257.1001.	1	5150.257.1001.	1
20	BALL BEARING 6208 EE	690.1005.	1	690.1005.	1	690.1005.	1
21	REAR WHEEL 302.40	800.1001.	1	800.1001.	1	800.1001.	1
22	SCREW H, M12-50	850.2012.	4	850.2012.	4	850.2012.	4
23	INTERTIA WHEEL GUARDING	5150.640.1008.	1	5150.640.1008.	1	5150.640.1008.	1
24	SPACER 240.1007. ZBJ	240.1031.	4	240.1031.	4	240.1031.	4
25	GEAR BOX + TRUMPET	5180.180.1007.	1	5200.180.1007.	1	5205.180.1007.	1
26	BREATHER 1/8 GAZ	670.1002.	1	670.1002.	1	670.1002.	1
27	DIPSTICK TCD 1/2 + A	390.1001	1	390.1001	1	390.1001	1
28	CAP	156.1005.	1	156.1005.	1	156.1005.	1
29	BOLT H, M12-35	4000.1018.	1	4000.1018.	1	4000.1018.	1
30	PROTECTION SLIDE BLOCK RD 150 / 180 / 200	5150.710.1002.	1	5150.710.1002.	1	5150.710.1002.	1
31	BOLT H, M12-70	4000.008.	1	4000.008.	1	4000.008.	1
32	CAP 3/8 G	155.1001.	1	155.1001.	1	155.1001.	1
33	CAP 3/8 G	155.1001.	1	155.1001.	1	155.1001.	1
34	BOLT M16-110	4000.1014.	1	4000.1014.	1	4000.1014.	1
35	CIRCLIPS 50 EXT	190.1004.	1	190.1004.	1	190.1004.	1
36	PITCH CHAIN WHEEL 16 TEETH PAS 38.1	600.1007.	1	600.1007.	1	600.1007.	1
37	SPACER 50 . 19 . L	139.1006.	1	139.1006.	1	139.1006.	1
38	BALL BEARING 6410	690.1009.	1	690.1009.	1	690.1009.	1
39	LEFT SIDE RD 150	5150.195.1003.	1	5150.195.1003.	1	5150.195.1003.	1

SPARE PARTS LIST DRAWING NR 1 RD 180 / 200 / 250

2/2

NR	DESIGNATIONS	SPARE PARTS REFERENCES					
		RD 180	QTY	RD 200	QTY	RD 250	QTY
40	NR OF THE MACHINE <	622		823		806	
	PACKING RING 54.72.10 DL	400.1005.	1	400.1005.	1	400.1005.	1
40	NR OF THE MACHINE >	622		823		806	
	PACKING RING 60.80.10 DL	400.1011.	1	400.1011.	1	400.1011.	1
41	FELT RING 60.90.6	415.1001.	1	415.1001.	1	415.1001.	1
42	SCREW CHc 12 x 35 12.9	850.3015.	6	850.3015.	6	850.3015.	6
43	EXTERIOR BLADE 90x8 S	450.1005.	6	450.1005.	6	450.1005.	6
44	NR OF THE MACHINE <	622		823		806	
	TRANSMISSION DISC RD150 Ø54	5150.630.1001.	1	5150.630.1001.	1	5150.630.1001.	1
44	NR OF THE MACHINE >	622		823		806	
	TRANSMISSION DISC RD150 Ø60	5150.630.1011.	1	5150.630.1011.	1	5150.630.1011.	1
45	ROTOR RD 180	5180.760.1004.	1				
45	ROTOR RD 200			5200.760.1005.	1		
45	ROTOR RD 250					5205.760.1075.	1
46	LEF BLADE 90x8	450.1004.	24	450.1004.	27	450.1004.	33
47	BOLT FOR BLADE 1/2 x 38	4000.002.	108	4000.002.	120	4000.002.	144
48	RIGHT BLADE 90x8	450.1003.	24	450.1003.	27	450.1003.	33
49	PLATE 148.75	5150.630.1003.	1	5150.630.1003.	1	5150.630.1003.	1
50	SCREW CHc 12 x 30 12.9	850.3019.	6	850.3019.	6	850.3019.	6
51	RIGHT SIDE RD180/200	5180.195.1005.	1	5180.195.1005.	1	5180.195.1005.	1
52	PACKING RING 40 . 58 . 10	400.1002.	1	400.1002.	1	400.1002.	1
53	BALL BEARING 22206	690.1017.	1	690.1017.	1	690.1017.	1
54	WASHER	695.1028.	1	695.1028.	1	695.1028.	1
55	CIRCLIPS 30 EXT	190.1002.	1	190.1002.	1	190.1002.	1
56	CAP FTE 74	178.1004.	1	178.1004.	1	178.1004.	1
57	CAP 3/8 G	155.1001.	1	155.1001.	1	155.1001.	1
58	SCREW CHc 8 x 25	850.3003.	3	850.3003.	3	850.3003.	3

SPARE PARTS LIST DRAWING NR 2 RD 180 / 200 / 250

NR	DESIGNATIONS	SPARE PARTS REFERENCES					
		RD 180	QTY	RD 200	QTY	RD 250	QTY
1	BALL BEARING 6309	690.1003.	1	690.1003.	1	690.1003.	1
2	PACKING RING 50x72x10 SL	400.1004.	1	400.1004.	1	400.1004.	1
3	SECONDARY SHAFT RD 180	100.1011.	1				1
3	SECONDARY SHAFT RD 200			100.1012.			1
3	SECONDARY SHAFT RD 250					100.1014.	1
4	LEFT TRUMPET RD 180	5180.760.1027.	1				
4	LEFT TRUMPET RD 200			5200.760.1037.	1		
4	LEFT TRUMPET RD 250					5205.760.1072.	1
5	BALL BEARING 6312	690.1010.	1	690.1010.	1	690.1010.	1
6	BEVEL WHEEL 108.43 23 TEETH	600.1006.	1	600.1006.	1	600.1006.	1
7	CIRCLIPS 45 E	190.1003.	1	190.1003.	1	190.1003.	1
8	PAPER GASKET 190.250	415.1003.	2	415.1003.	2	415.1003.	2
9	PIN Ø6 Lg40	340.1009.	1	340.1009.	1	340.1009.	1
10	NUT Hm 30*200 G	260.1007.	1	260.1007.	1	260.1007.	1
11	PRIMARY SHAFT RD 150	100.1003.	1	100.1003.	1	100.1003.	1
12	CAP FTE 80.D	178.1001.	1	178.1001.	1	178.1001.	1
13	PACKING RING 40x62x10 DL	400.1003.	1	400.1003.	1	400.1003.	1
14	PAPER GASKET 100	415.1008.	2	415.1008.	2	415.1008.	2
15	BALL BEARING 30308	690.1014.	1	690.1014.	1	690.1014.	1
16	BEVEL GEAR 12 TEETH 108.43	600.1003.	1	600.1003.	1	600.1003.	1
17	NON PARRALEL SHAFT CASE FTE 180	180.1007.	1	180.1007.	1	180.1007.	1
18	RIGHT TRUMPET RD 180	5180.760.1036.	1				
18	RIGHT TRUMPET RD 200			5200.760.1038.	1		
18	RIGHT TRUMPET RD 250					5205.760.1073.	1
19	WASHER W 12 ZBJ	695.1019.	24	695.1019.	24	695.1019.	24
20	SCREW T.H M12 * 35 ZBJ	850.2018.	24	850.2018.	24	850.2018.	24
21	SPACER 40x50x158	139.1007.	1	139.1007.	1	139.1007.	1
22	BALL BEARING 6406	690.1007.	1	690.1007.	1	690.1007.	1
23	WASHER FOR PRIMARY SHAFT Ø30 x 50 x 7	695.1046.	1	695.1046.	1	695.1046.	1
24	REAR CAP 90.D	178.1005.	1	178.1005.	1	178.1005.	1
25	CAP 1/2 G	155.1005.	1	155.1005.	1	155.1005.	1
26	CIRCLIPS Ø30 E	190.1002.	1	190.1002.	1	190.1002.	1

SPARE PARTS LIST DRAWING NR 3 RD 180 / 200 / 250

1/2

NR	DESIGNATIONS	SPARE PARTS REFERENCES					
		RD 180	QTY	RD 200	QTY	RD 250	QTY
1	PEG BETA 4,5	340.1003	1	340.1003	1	340.1003	1
2	HITCHING AXIS 19 * 25	120.1001	1	120.1001	1	120.1001	1
3	LEFT TOPLINK TUBE	5150.760.G018	1	5150.760.G018	1	5150.760.G018	1
4	SCREW T.H 12 * 30 ZBJ	850.2016	4	850.2016	4	850.2016	4
	NUT M12 DIN 985	260.1012	4	260.1012	4	260.1012	4
5	PEG BETA 6	340.1001	2	340.1001	2	340.1001	2
6	HITCHING AXIS 22 * 28	120.U002	2	120.U002	2	120.U002	2
7	PROTECTION TUBE LEFT	5150.760.D023	1	5150.760.D023	1	5150.760.D023	1
7'	PROTECTION TUBE RIGHT	5150.760.G023	1	5150.760.G023	1	5150.760.G023	1
8	SCREW T.H 12 * 30 ZBJ	850.2016	4	850.2016	4	850.2016	4
	NUT M12 DIN 985	260.1012	4	260.1012	4	260.1012	4
9	SCREW T.H 12 * 60 ZBJ	850.2009	2	850.2009	2	850.2009	2
	NUT M12 DIN 985	260.1012	2	260.1012	2	260.1012	2
	NUT M12 DIN 4032	260.1014	2	260.1014	2	260.1014	2
10	SELECTION GRATE SPRING	660.1005	2	660.1005	2	660.1005	2
11	SCREW T.H 12 * 35 ZBJ	850.2018	4	850.2018	4	850.2018	4
	WASHER W 12 ZBJ	695.1019	4	695.1019	4	695.1019	4
12	SCREW T.H 12 * 80 ZBJ	850.2018	2	850.2018	2	850.2018	2
	NUT M12 DIN 4032	260.1014	2	260.1014	2	260.1014	2
13	GRATE FINGER	210.1002	58	210.1002	65	210.1002	82
14	GRATE FINGER SUPPORT RD 180	5180.770.1020	1				
14	GRATE FINGER SUPPORT RD 200			5200.770.1022	1		
14	GRATE FINGER SUPPORT RD 250					5205.770.1080	1
15	GRATE FINGER FLANGE	150.1001	14,5	150.1001	16,5	150.1001	20,5
16	SCREW CHC 10 * 35	850.3002	59	850.3002	66	850.3002	83
	NUT M10 ZBJ	260.1011	59	260.1011	66	260.1011	83
17	GUARDING PLATE RD 180	770.1021	1				
	GUARDING PLATE RD 200			770,1023	1		
	GUARDING PLATE RD 250					770,1083	1
18	SCREW T.H 10 * 25 ZBJ	850.2003	4	850.2003	4	850.2003	4
	WASHER MU 10 ZBJ	695.1017	4	695.1017	4	695.1017	4

SPARE PARTS LIST DRAWING NR 3 RD 180 / 200 / 250

2/2

NR	DESIGNATIONS	SPARE PARTS REFERENCES					
		RD 180	QTY	RD 200	QTY	RD 250	QTY
19	SPRING HANDLE	5075.620.1019	2	5075.620.1019	2	5075.620.1019	2
20	SCREW T.H 12 * 130 ZBJ	850.2029	4	850.2029	4	850.2029	5
	NUT M12 DIN 985	260.1012	4	260.1012	4	260.1012	5
21	GRATE HINGE	5100.240.1005	4	5100.240.1005	4	5100.240.1005	5
22	SCREW T.H 12 * 30 ZBJ	850.2016	8	850.2016	8	850.2016	10
	NUT M12 DIN 985	260.1012	8	260.1012	8	260.1012	10
23	ARMS FORK	5150.640.1006	2	5150.640.1006	2	5150.640.1006	2
24	SCREW T.H 12 * 30 ZBJ	850.2016	8	850.2016	8	850.2016	8
	NUT M12 DIN 985	260.1012	8	260.1012	8	260.1012	8
25	SCREW T.H 12 * 35 ZBJ	850.2018	4	850.2018	4	850.2018	4
	WASHER W 12 ZBJ	695.1019	4	695.1019	4	695.1019	4
26	TOPLINK	5150.750.1091	1	5150.750.1091	1	5150.750.1091	1
27	SCREW T.H 12 * 90	850.1021	2	850.1021	2	850.1021	2
	NUT M12 DIN 985	260.1012	2	260.1012	2	260.1012	2
28	RIGHT TOPLINK TUBE	5150.760.D018	1	5150.760.D018	1	5150.760.D018	1

SPARE PARTS LIST DRAWING NR 4 RD 180 / 200 / 250

NR	DESIGNATIONS	SPARE PARTS REFERENCES					
		RD 180	QTY	RD 200	QTY	RD 250	QTY
1	MESH ROLLER FRAME RD 180	5180.750.1084	1				
	MESH ROLLER FRAME RD 200			5200.750.1085	1		
	MESH ROLLER FRAME RD 250					5205.750.1145	1
2	DRIFT WITH HANDLE	151.1002	2	151.1002	2	151.1002	2
3	ARMS FORK	5150.640.1006	2	5150.640.1006	2	5150.640.1006	2
4	FEMALE ARM	5150.270.1011	2	5150.270.1011	2	5150.270.1011	2
5	SCREW T.H 14 * 30 ZBJ	850.2005	4	850.2005	4	850.2005	4
6	CRANK FOR ARMS	5100.640.1001	4	5100.640.1001	4	5100.640.1001	4
7	CRANK PIN	610.1001	4	610.1001	4	610.1001	4
8	PEG CLIPS 6	340.1005	4	340.1005	4	340.1005	4
9	PEG 6 * 26	340.1007	4	340.1007	4	340.1007	4
10	GREASER	320.1001	4	320.1001	4	320.1001	4
11	SCREW FOR CRANK	5100.850.1039	2	5100.850.1039	2	5100.850.1039	2
	SCREW FOR CRANK NIV GRADER	5180.850.1043	2	5180.850.1043	2	5180.850.1043	2
12	NUT M14 ZBJ DIN 985	260.1013	4	260.1013	4	260.1013	4
13	SCREW T.H 14 * 35 ZBJ	850.2019	4	850.2019	4	850.2019	4
14	BEARING Ø 30	690.1021	2	690.1021	2	690.1021	2
15	SCRAPER RD 180	5180.725.1004	1				
	SCRAPER RD 200			5200.725.1005	1		
	SCRAPER RD 250					5205.725.1016	1
16	SMOOTHED DISTANCE PIECE RING	240.1031	2	240.1031	2	240.1031	2
17	NUT M12 ZBJ DIN 985	260.1012	4	260.1012	4	260.1012	4
18	WASHER 13 * 42 * 4 ZBJ	695.1027	4	695.1027	4	695.1027	4
19	SCREW TH 12 * 40 ZBJ	850.2006	4	850.2006	4	850.2006	4
20	MESH ROLLER RD 180	5180.505.1005	1				
	MESH ROLLER RD 200			5200.505.1007	1		
	MESH ROLLER RD 250					5205.505.1007	1
21	NIV GRADER RD 180	5180.450.1019	1				
	NIV GRADER RD 200			5200.450.1012	1		
	NIV GRADER RD 250					5205.450.1043	1
22	CAP	156.1004	4	156.1004	4	156.1004	4

SPARE PARTS LIST DRAWING NR 5 RD 180 / 200 / 250

NR	DESIGNATIONS	SPARE PARTS REFERENCES					
		RD 180	QTY	RD 200	QTY	RD 250	QTY
1	PACKER ROLLER FRAME RD 180	5180.750.1009	1				
	PACKER ROLLER FRAME RD 200			5200.750.1008	1		
	PACKER ROLLER FRAME RD 250					5205.750.1147	1
2	DRIFT WITH HANDLE	151.1002	2	151.1002	2	151.1002	2
3	ARMS FORK	5150.640.1006	2	5150.640.1006	2	5150.640.1006	2
4	FEMALE ARM	5150.270.1011	2	5150.270.1011	2	5150.270.1011	2
5	SCREW T.H 14 * 30 ZBJ	850.2005	4	850.2005	4	850.2005	4
6	ARM CRANK	5100.640.1001	4	5100.640.1001	4	5100.640.1001	4
7	CRANK PIN	610.1001	4	610.1001	4	610.1001	4
8	PEG CLIPS 6	340.1005	4	340.1005	4	340.1005	4
9	PEG 6 * 26	340.1007	4	340.1007	4	340.1007	4
10	GREASER	320.1001	4	320.1001	4	320.1001	4
11	SCREW FOR ARM CRANK	5100.850.1039	2	5100.850.1039	2	5100.850.1039	2
	SCREW FOR BLADE CRANK	5180.850.1043	2	5180.850.1043	2	5180.850.1043	2
12	NUT M14 ZBJ DIN 985	260.1013	4	260.1013	4	260.1013	4
13	BEARING Ø 30	690.1021	2	690.1021	2	690.1021	2
14	SCREW T.H 14 * 35 ZBJ	850.2019	4	850.2019	4	850.2019	4
15	NUT M12 ZBJ DIN 985	260.1012	4	260.1012	4	260.1012	4
16	WASHER 13 * 42 * 4 ZBJ	695.1027	2	695.1027	2	695.1027	2
17	SMOOTHED DISTANCE PIECE RING	240.1031	2	240.1031	2	240.1031	2
18	SCREW TH 12 * 40 ZBJ	850.2006	4	850.2006	4	850.2006	4
19	SCRAPER RD 180	5180.750.1031	1				
	SCRAPER RD 200			5200.750.1016	1		
	SCRAPER RD 250					5205.750.1144	1
20	NUT M10 ZBJ DIN 985	260.1011	33	260.1011	37	260.1011	46
21	CLEANING SCRAPER	200.1001	33	200.1001	37	200.1001	46
22	SCREW TRCC 10 * 80 ZB	850.2034	33	850.2034	37	850.2034	46
23	CAP	156.1001	2	156.1001	2	156.1001	2
24	ROLLER TUBE RD 180	5180.760.1064	1				
	ROLLER TUBE RD 200			5200.760.1065	1		
	ROLLER TUBE RD 250					5205.760.1076	1
25	DISC	158.1002	32	158.1002	36	158.1002	45
26	1/2 DISC	158.1004	2	158.1004	2	158.1004	2
27	DISC CLAMP	158.1006	2	158.1006	2	158.1006	2
28	NIV GRADER RD 180	5180.450.1019	1				
	NIV GRADER RD 200			5200.450.1012	1		
	NIV GRADER RD 250					5205.270.1003	1
29	SCREW CHC 12 * 60 12.9	850.3017	2	850.3017	2	850.3017	2
	NUT M12 DIN 985	260.1012	2	260.1012	2	260.1012	2
30	CAP	156.1004	4	156.1004	4	156.1004	4