

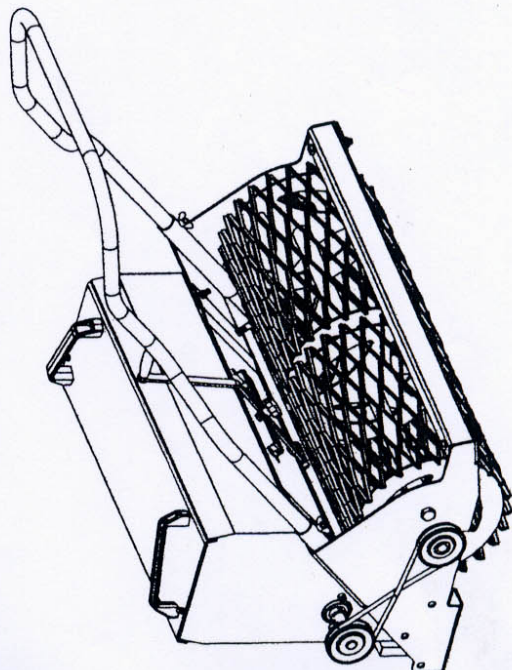

SEEDY

Planche 1

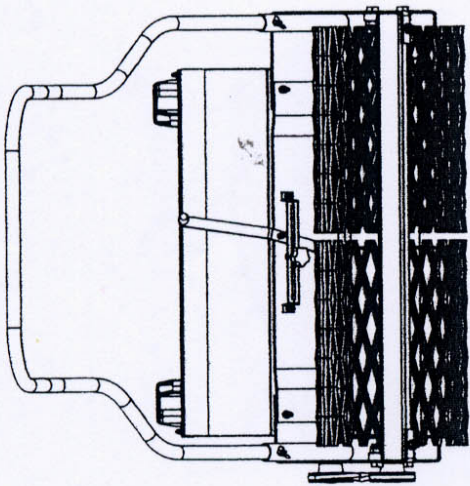

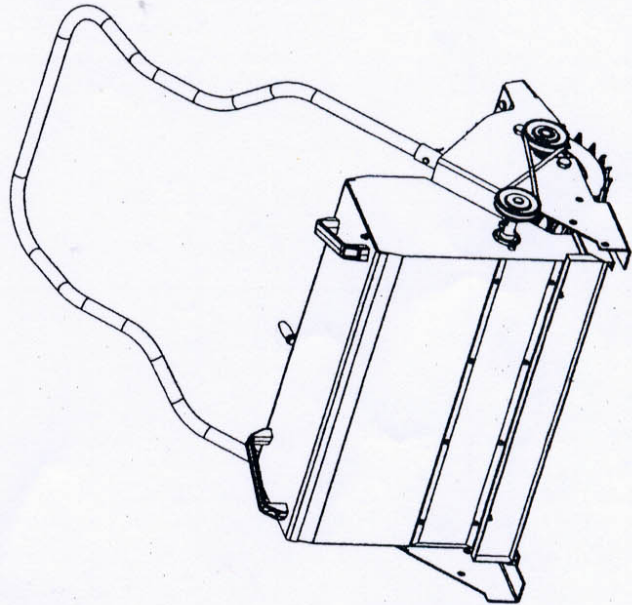
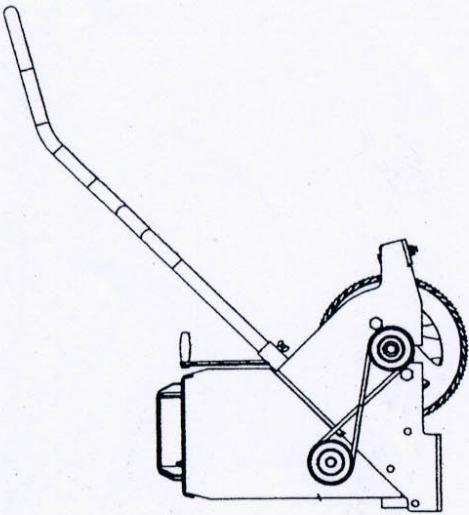
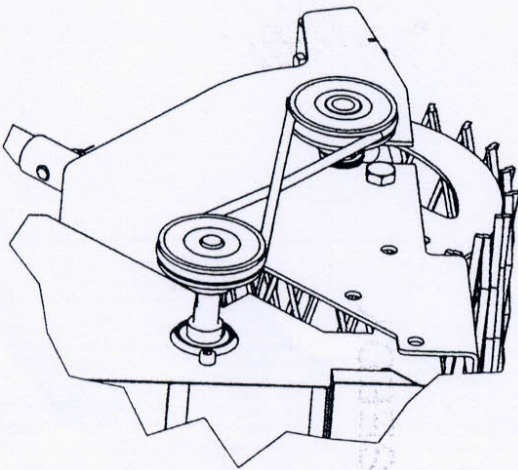

SEEDY

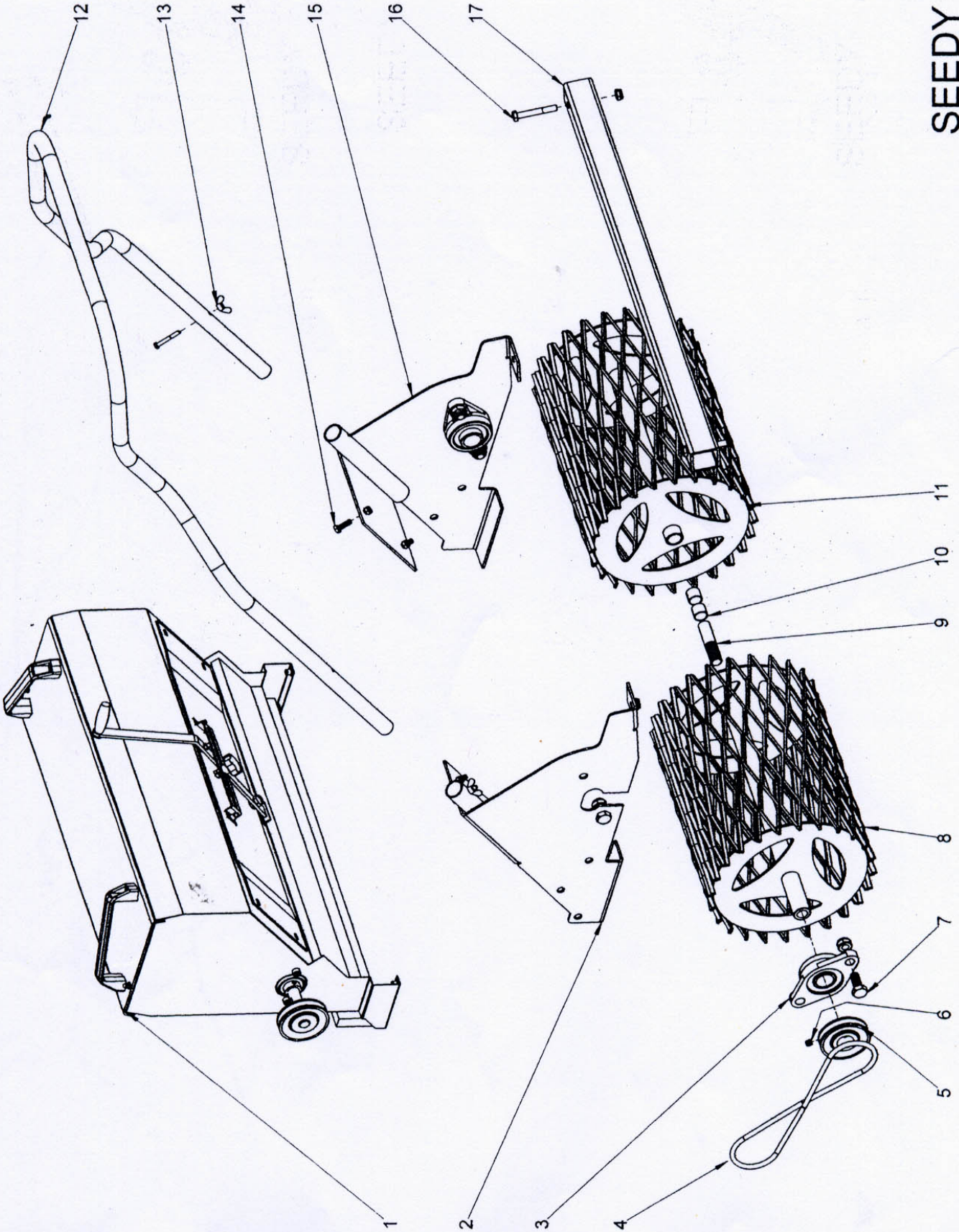

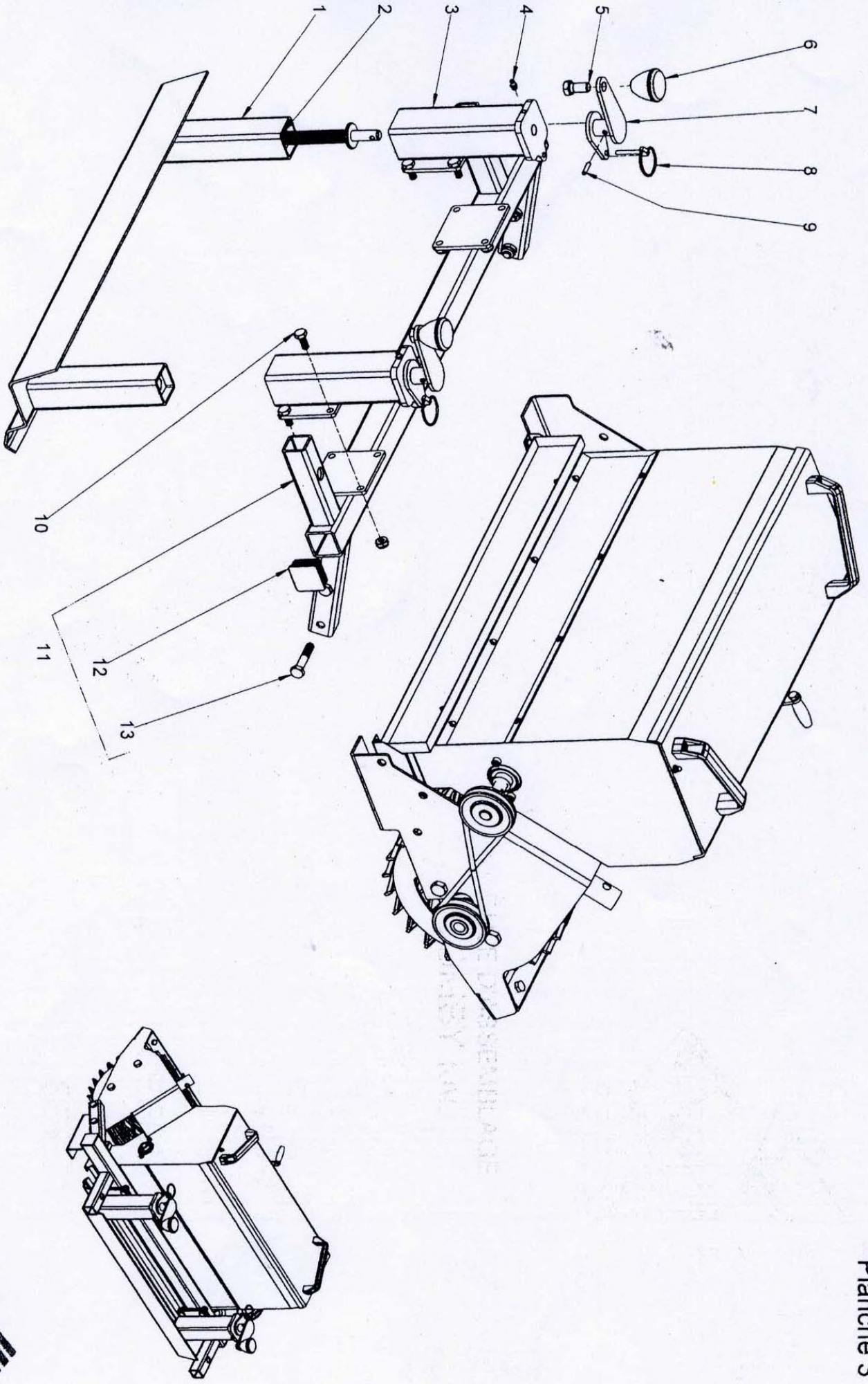

MODULE D'ASSEMBLAGE  
COMBY NIV.



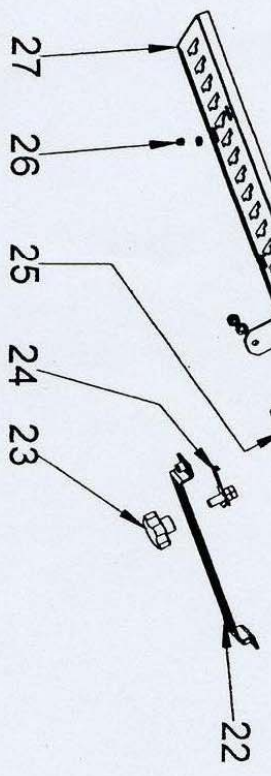
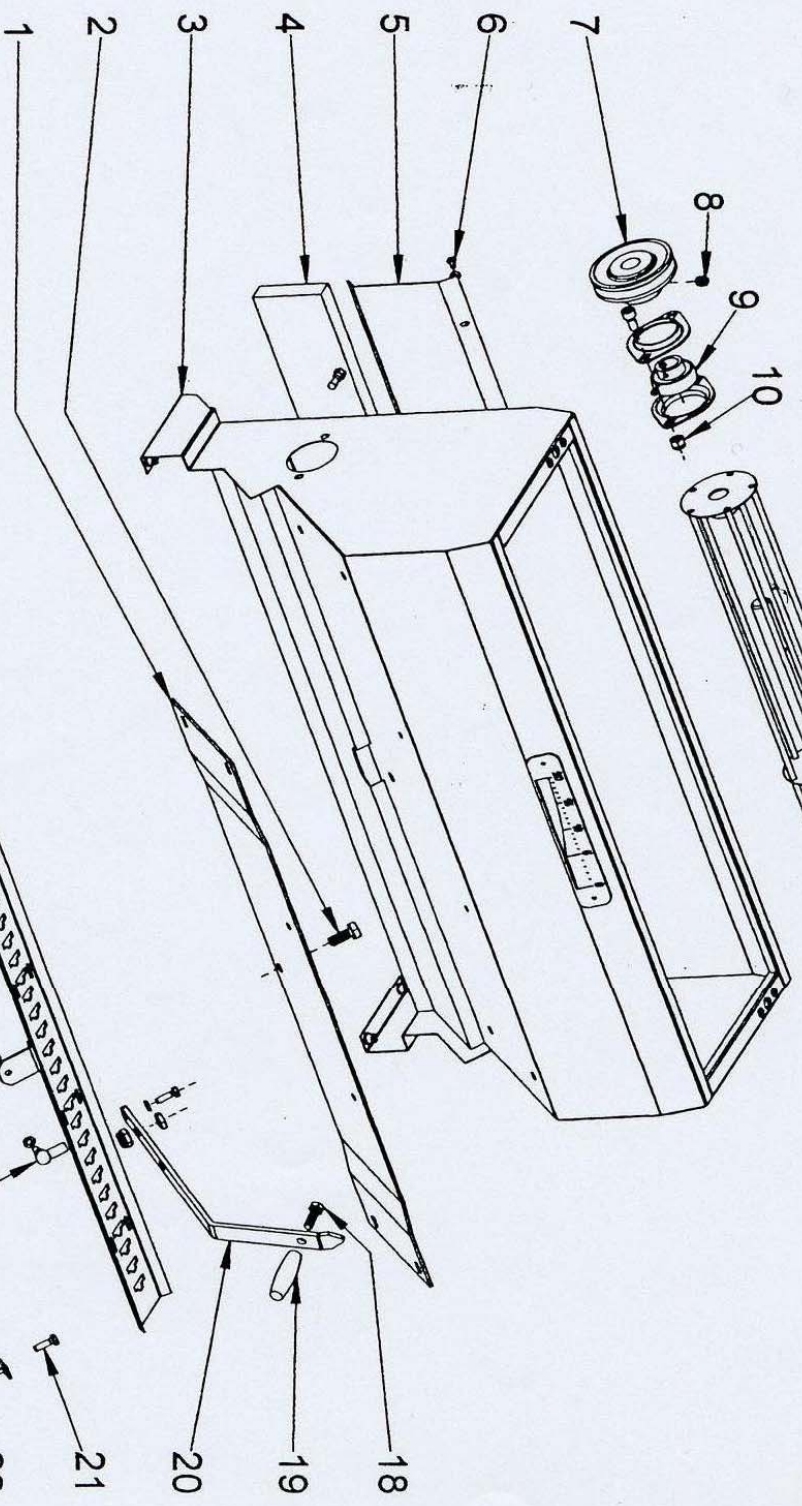
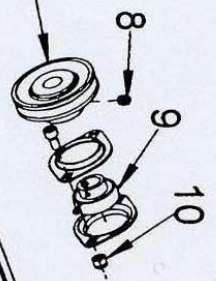
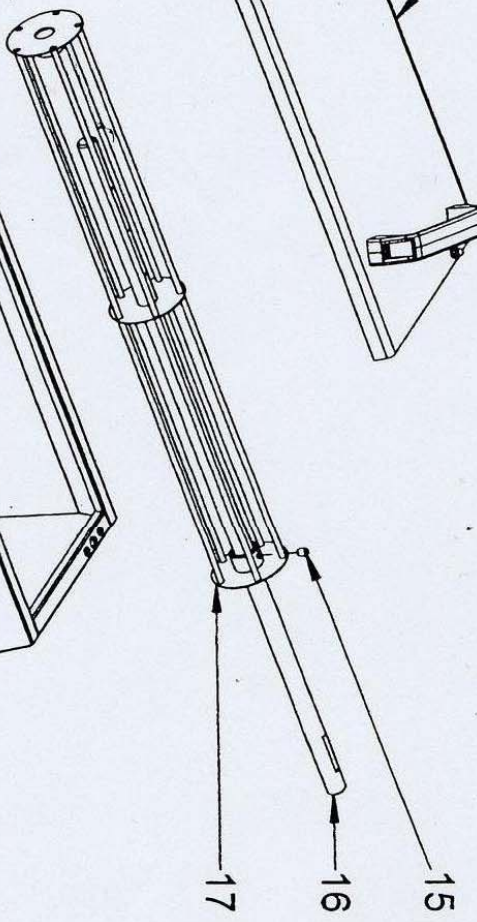
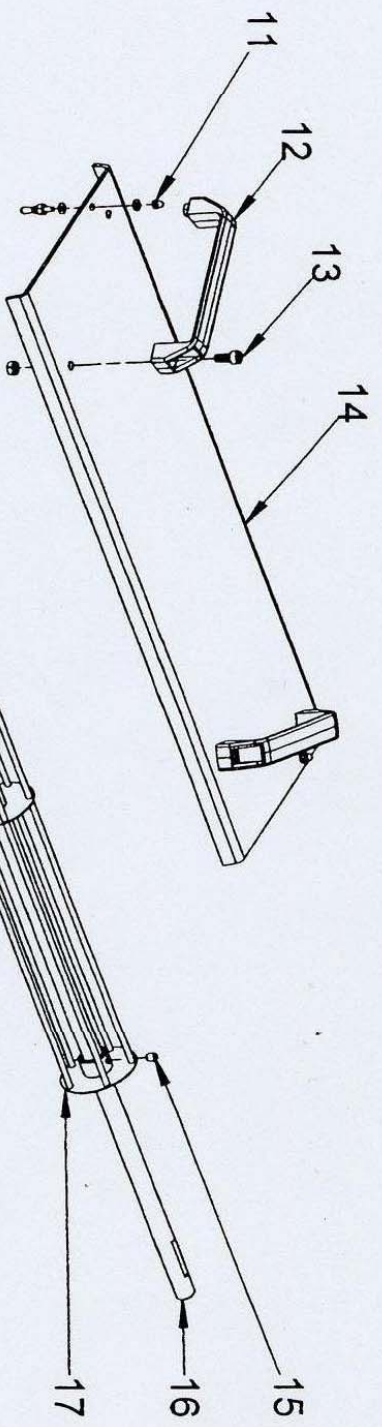

TREMIE SEEDY  
ACIER INOXYDABLE

Planche 4



**PARTS LIST      DRAWING NR 2 SEEDY**

NR	DESIGNATION	PARTS REFERENCES	QTY
1	SEE DRAWING NR 4/4		
2	LEFT FLANGE	6075.270.1041	1
3	BEARING	690.1021	2
4	BELT DRIVE	196.1001	1
5	BOTTOM PULLEY	600.1015	1
6	SCREW STHC 10 *10	850.4002	2
7	SCREW T.H 14 * 35 ZBJ	850.2019	4
	NUT M14 ZBJ	260.2013	4
8	LEFT ROLLER	6075.100.1019	1
9	AXEL PIVOT	120.1014	1
10	FRICTION RING	130.1003	2
11	RIGHT ROLLER	6075.100.1018	1
12	HANDLE	350.U001	1
13	SCREW T.H 6 * 45 ZBJ	850.2037	2
	NUT M6	260.1017	2
14	SCREW T.H 8 * 25 ZBJ	850.2020	4
	WASHER MU 8 ZBJ	695.1062	4
	NUT M 8 ZBJ	260.1010	4
15	RIGHT FLANGE	6075.750.1040	1
16	SCREW T.H 10 * 70	850.2038	2
	NUT M10 ZBJ	260.1011	2
17	REAR TUBE	750.U029	1

**PARTS LIST DRAWING NR 3 SEEDY**

NR	DESIGNATION	PARTS REFERENCES	QTY
1	NIV GRADER	5075.450.1035	1
2	SCREW FOR CRANK	5100.850.1039	2
3	FEMALE TUBE	5036.640.1055	2
4	GREASER	320.1001	2
5	SCREW T.H 14 * 30 ZBJ	850.2005	2
6	HANDLE	610.1001	2
7	CRANK FOR ARM	5036.640.1031	2
8	PEG CLIPS Ø 6	340.1005	2
9	PEG 6 * 26	340.1007	2
10	SCREW CHC 10 * 25 ZBJ	850.3024	8
	NUT M10 ZBJ	260.1011	8
11	FITTING KIT / STONY	5075.750.1039	1
12	CAP 50	156.1001	2
13	SCREW T.H 12 * 60 ZBJ	850.2009	4
	NUT M12 ZBJ	260.1012	4

**T : Technical parts and tools (20 %discount)**

**PARTS LIST DRAWING NR 4 SEEDY**

&gt;428

NR	DESIGNATION	PARTS REFERENCES	QTY
1	SUPPORT PLATE SEED BOX	715-1001-A	1
2	SCREW T,H 10*25 ZBJ	850-2003	1
	NUT Hm 10	260-4001	1
	NUT M10 ZBJ DIN 985	260-1011	1
3	SEED BOX STAINLESS STEEL	715-1001	1
4	SEED TRAY	715-1001-B	1
5	FRONT PLATE	715-1001-C	1
6	SCREW T.H 4 * 12 INOX	850-4004	8
	WASHER MU 4 INOX	695-4001	8
7	PULLEY	600-1014	1
8	SCREW HC 10 * 10 INOX	850-4002	1
9	BEARING SLFL Ø 20	690-1022	2
10	SCREW CHC 8 * 16 INOX	850-4005	4
	NUT M8 INOX DIN 985	260-4005	4
11	NUT M5 INOX	260-4010	2
	WASHER MU 5 INOX	695-4004	4
	CENTERING PIN	715-1001-D	2
12	HANDLE M 443 BLACK	610-1003	2
13	SCREW CHC 8 * 20 INOX	850-4006	4
	NUT M8 INOX	260-4004	4
14	COVER SEED BOX	197-1004	1
15	SCREW HC 8 * 10 INOX	850-4001	2
16	AXIS AGITATOR	120-1015	1
17	AGITATOR	715-1001-E	1
18	SCREW T.H 8 * 25 ZBJ	850-2024	1
19	HANDLE SEED RATE ADJUSTER	610-1005	1
20	SEED RATE ADJUSTER	715-1001-F	1
21	SCREW T.H 6 * 20 INOX	850-4003	2
22	ADJUSTER GUIDE	715-1013-C	1
23	HANDLE ADJUSTER	610-1006	1
24	SCREW STOP SEED RATE ADJUSTE	715-1013-D	1
25	KNUCKLE JOINT 90° RIGHT	692-1003	1
	SCREW T.H 6 * 20 INOX	850-4003	1
	WASHER MU 6 INOX	695-4003	3
	NUT INOX M6 DIN 985	260-4009	1
26	NUT INOX M4 DIN 985	260-4003	8
	WASHER MU 4 INOX	695-4001	8
27	RACK	715-1001-G	1



**T : Technical parts and tools (20 %discount)**