

# KOHLER® COMMAND PRO®

6-14 HP Engines



**KOHLER®**  
IN POWER. SINCE 1920.

Compliance Information  
- Daily Each Use  
- Total 5 hrs.  
- Every 100 hrs./Annually  
- Kohler 10W-30 Oil  
- Recommended  
- Daily Each Use  
www.kohlerengines.com



KOHLER

# BUILT TO FINISH EVERY JOB IT STARTS.

This is what it takes to be a PRO. Performance enhancing features like a heavy-duty air cleaner, forged-steel crankshaft, electronic ignition and cast-iron cylinder liner. KOHLER® Command PRO® is the standard for professional-grade power and performance.

## KOHLER® COMMAND PRO®

### DEPENDABLE OPERATION

- Quad-Clean™ all-season four-stage cyclonic air filter—effective engine protection for tough-and-dirty conditions
- Protects from airborne contaminants that can easily clog traditional air filters

### LONGER RUNTIMES

- Large-capacity fuel tank means more time working, less time filling
- Electronic ignition and an advanced combustion system design help reduce fuel consumption

### EASIER REPOWERING

- Power or repower your equipment without expensive modifications

### ALL-WEATHER PERFORMANCE

- Quad-Clean air filter reconfigures in seconds to recycle engine heat
- Command PRO engine starts effortlessly in all weather conditions, from 0 to 110 degrees

### BUILT TO LAST

- Forged-steel crankshafts and tough Stellite®-faced exhaust valves with Tufftride-coated stems and cast-iron cylinder bores
- Oil Sentry™ system automatically shuts engine down in low-oil conditions







# KOHLER® COMMAND PRO®

## 6-HP Horizontal Shaft Engines

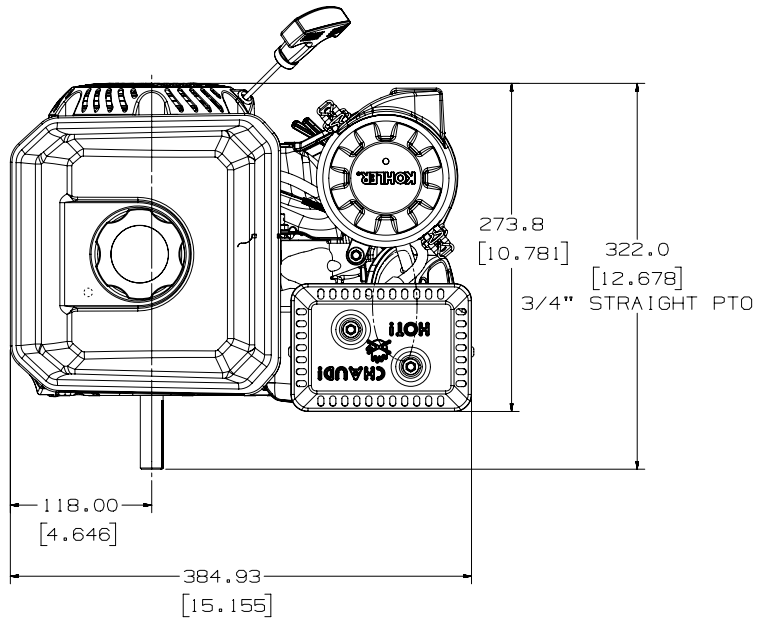

Top view

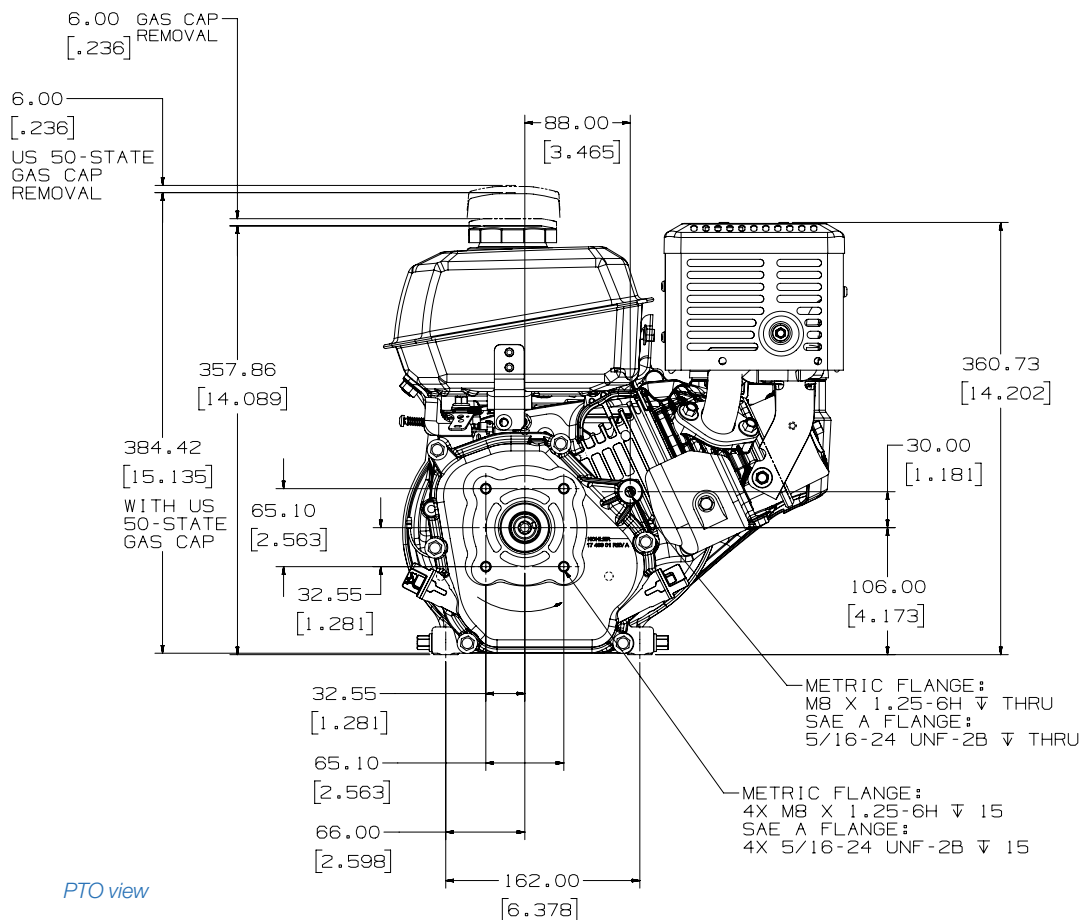

PTO view



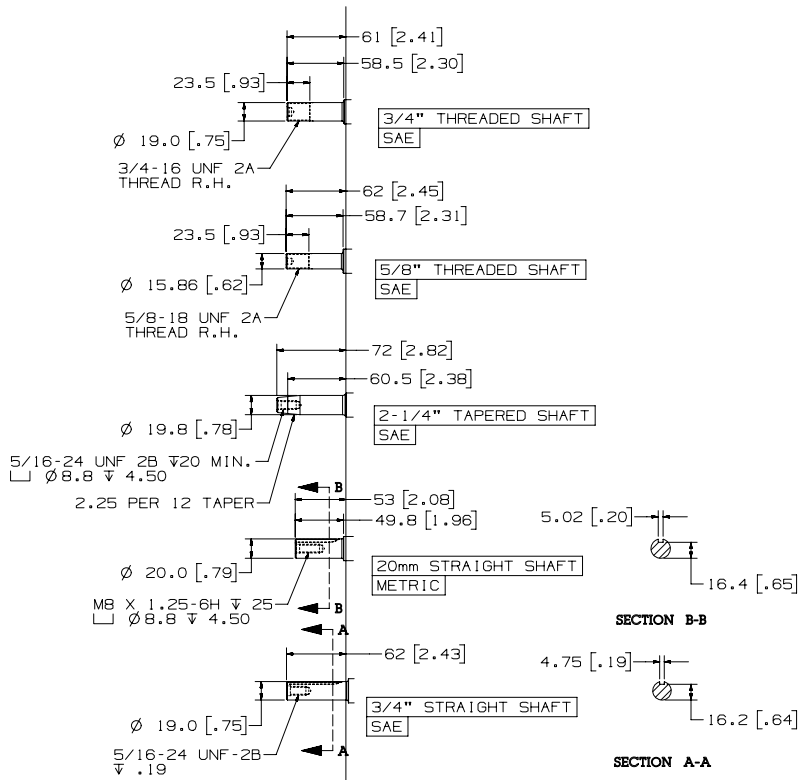

Shaft variations

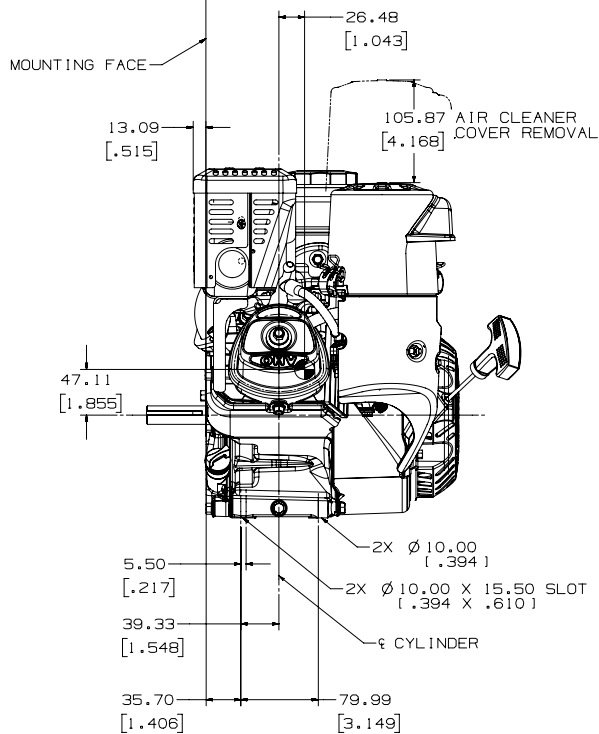

Valve cover view

### MAXIMUM POWER

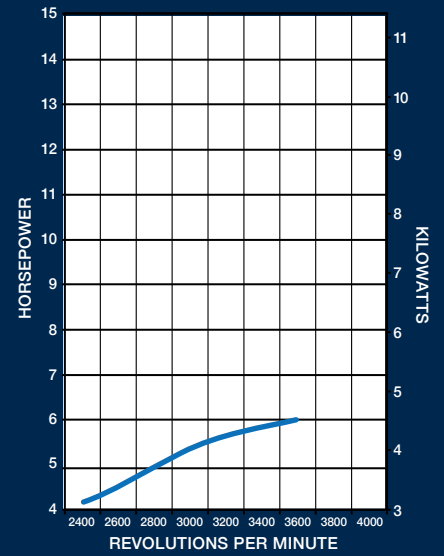

### MAXIMUM TORQUE

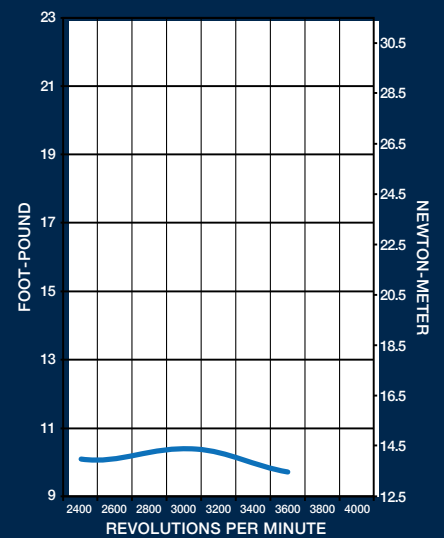

# KOHLER® COMMAND PRO®

## 7-HP Horizontal Shaft Engines

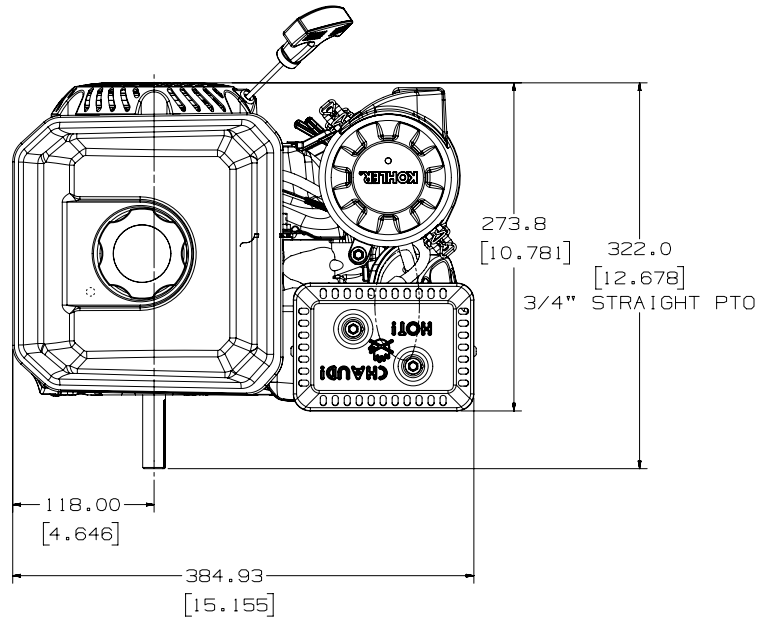

Top view

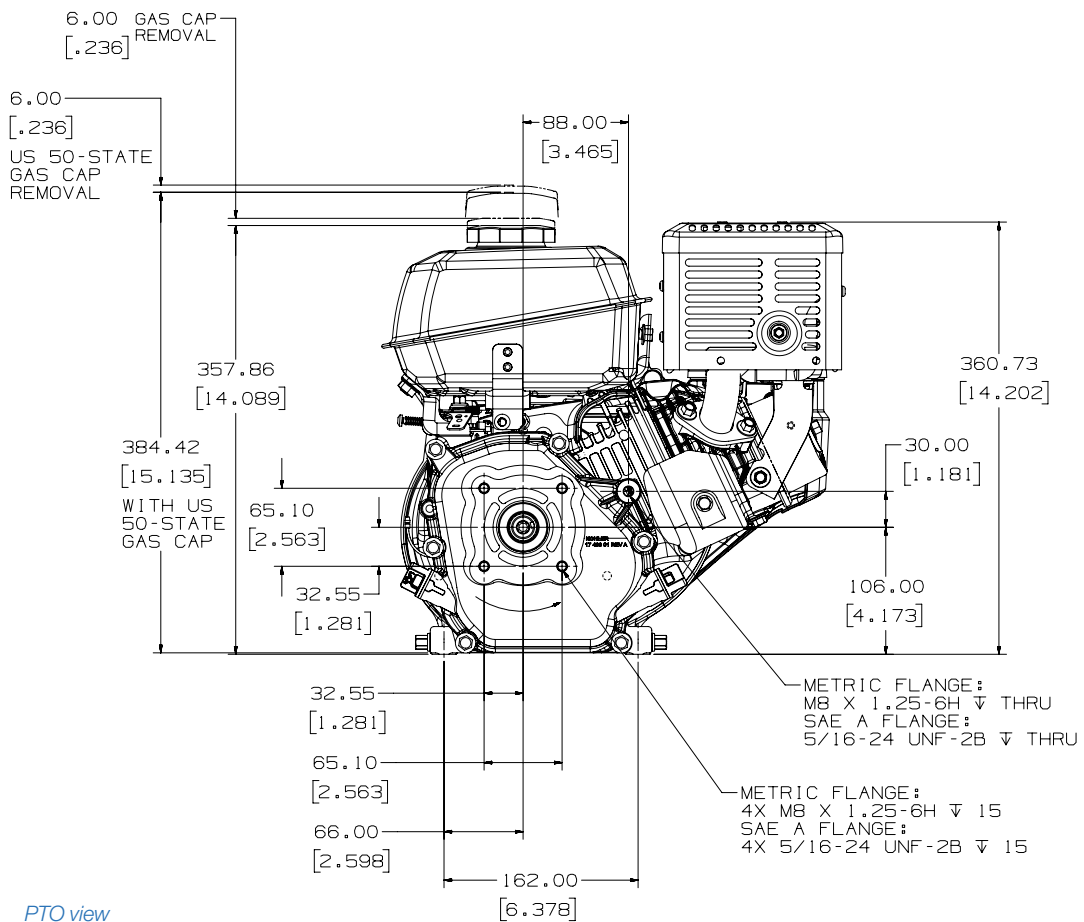

PTO view



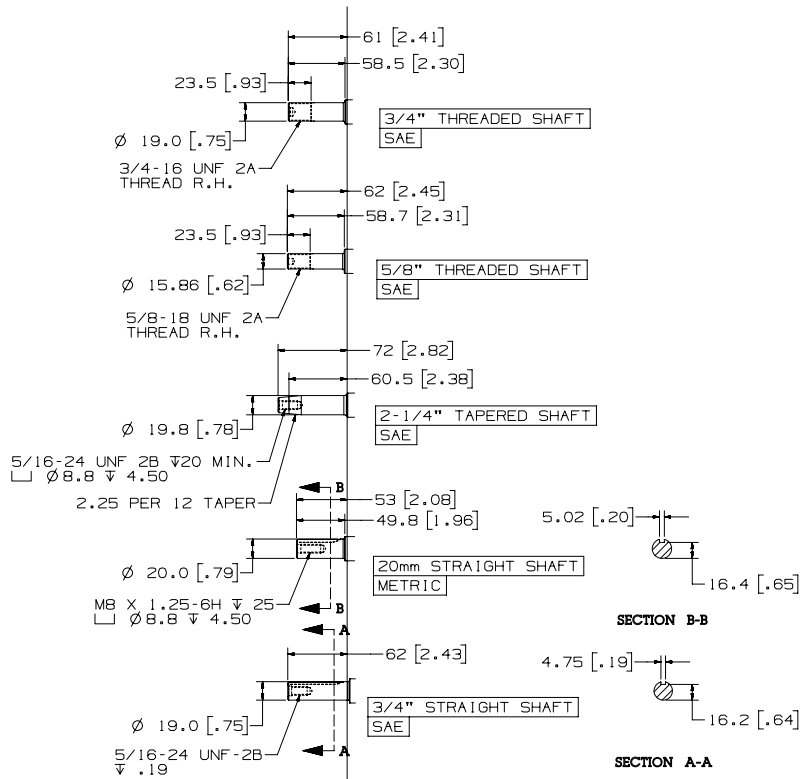

Shaft variations

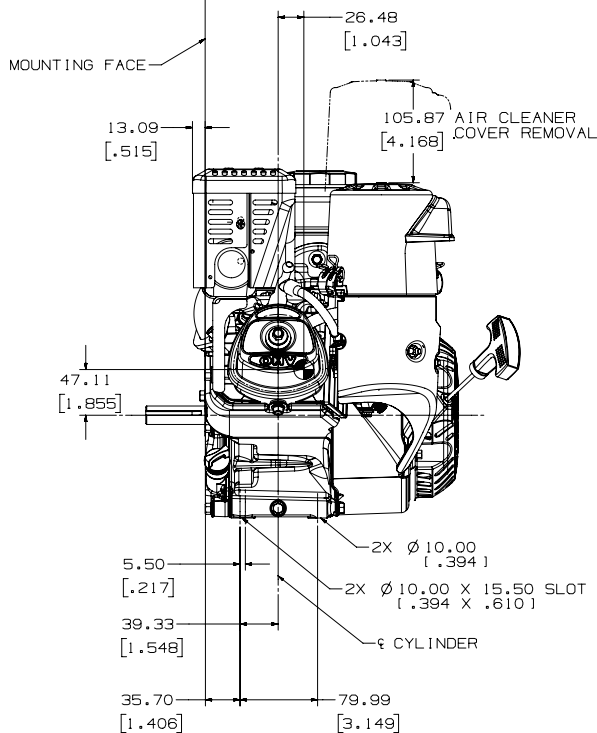

Valve cover view

### MAXIMUM POWER

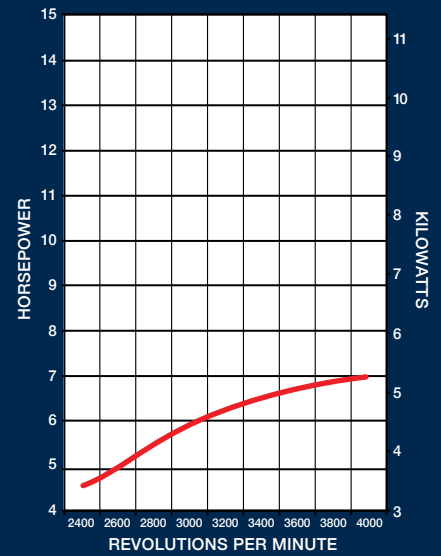

### MAXIMUM TORQUE

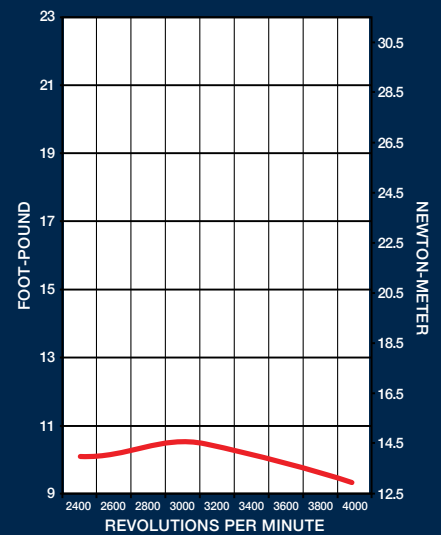





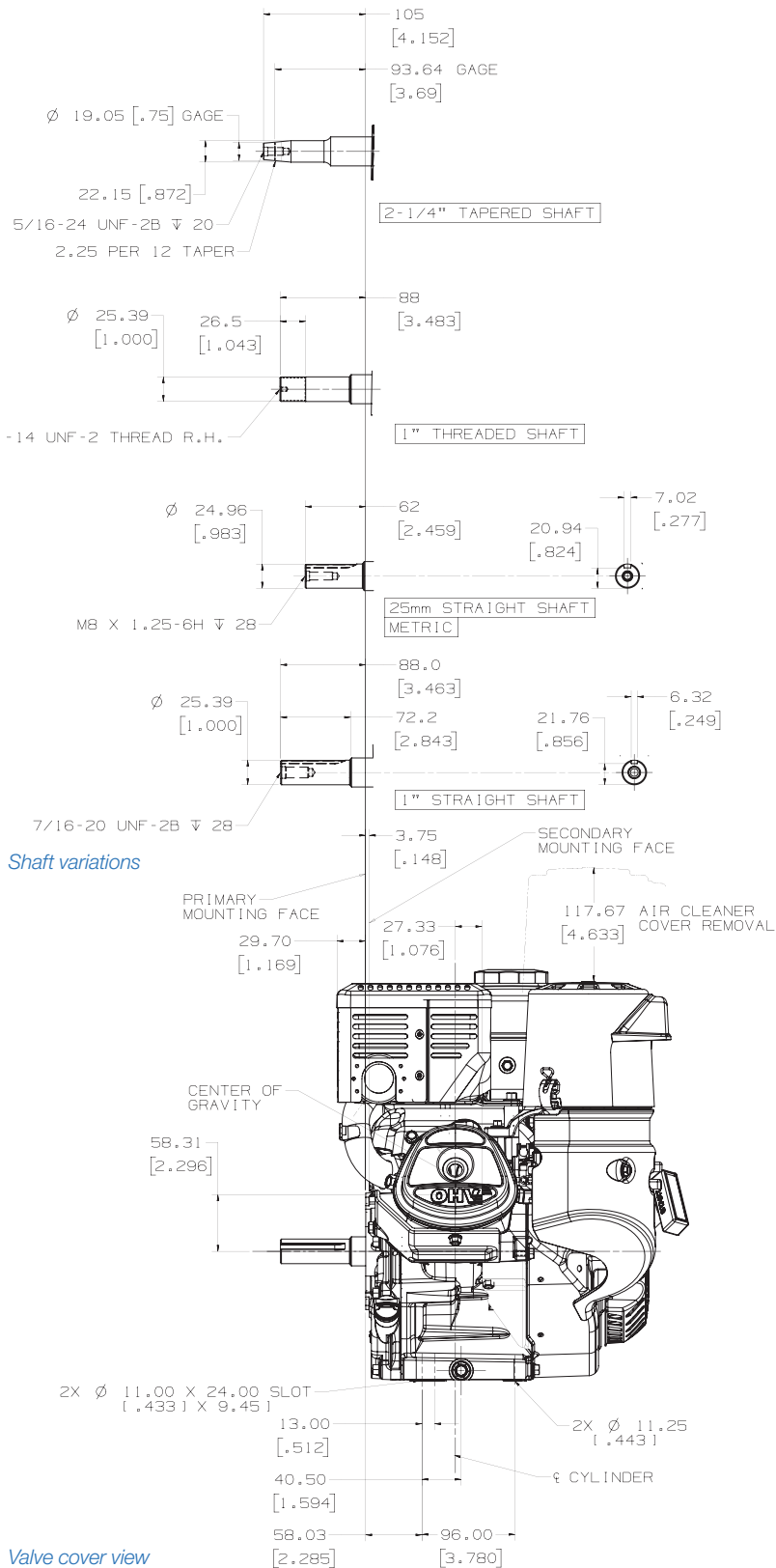

### MAXIMUM POWER

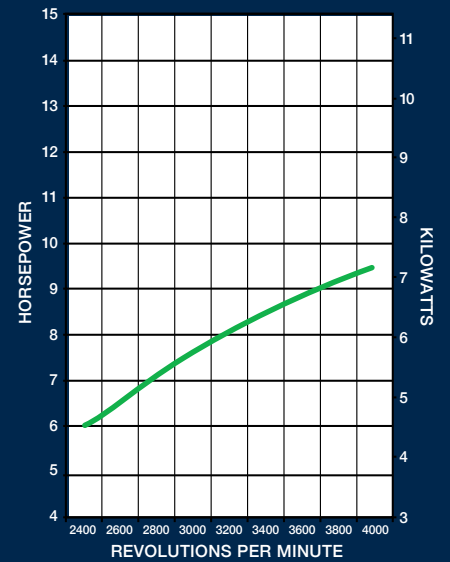

### MAXIMUM TORQUE

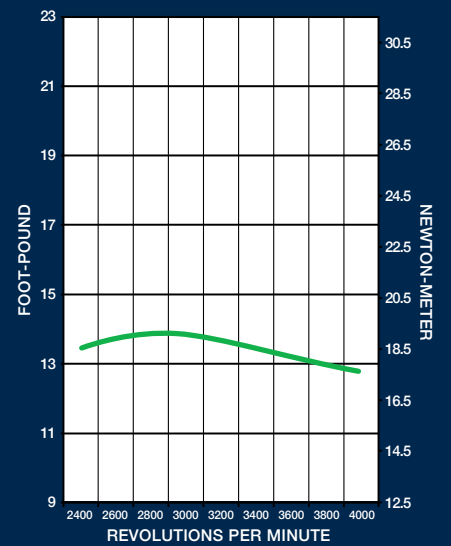

# KOHLER® COMMAND PRO®

## 14-HP Horizontal Shaft Engines

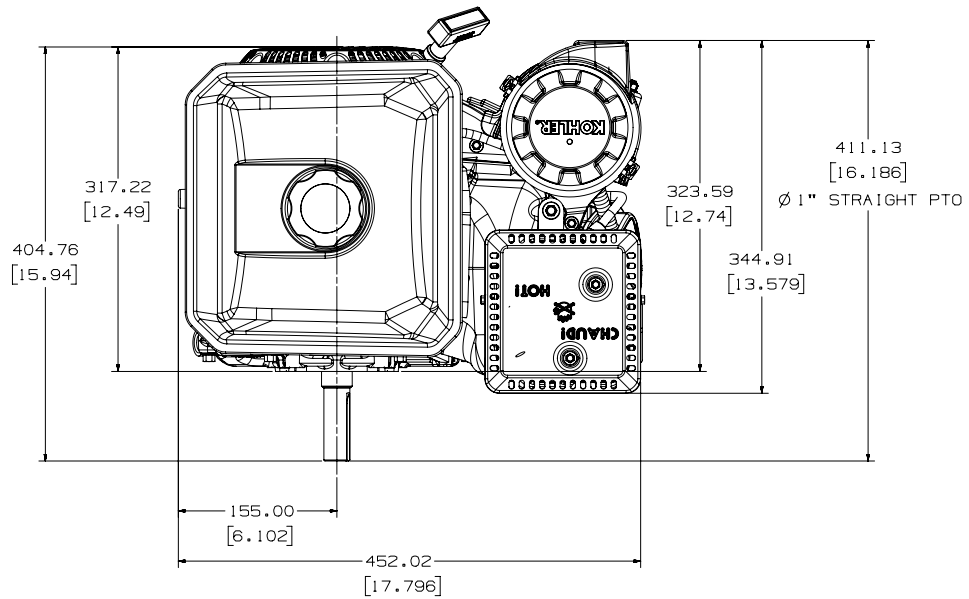

Top view

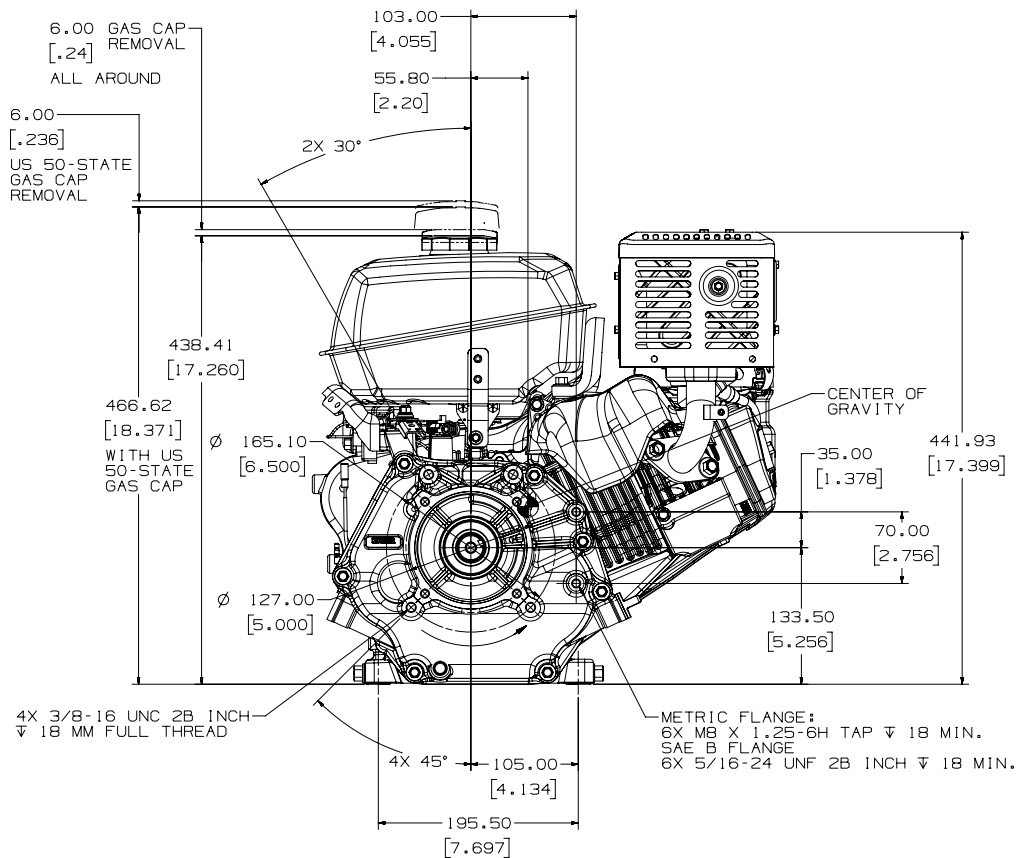

PTO view



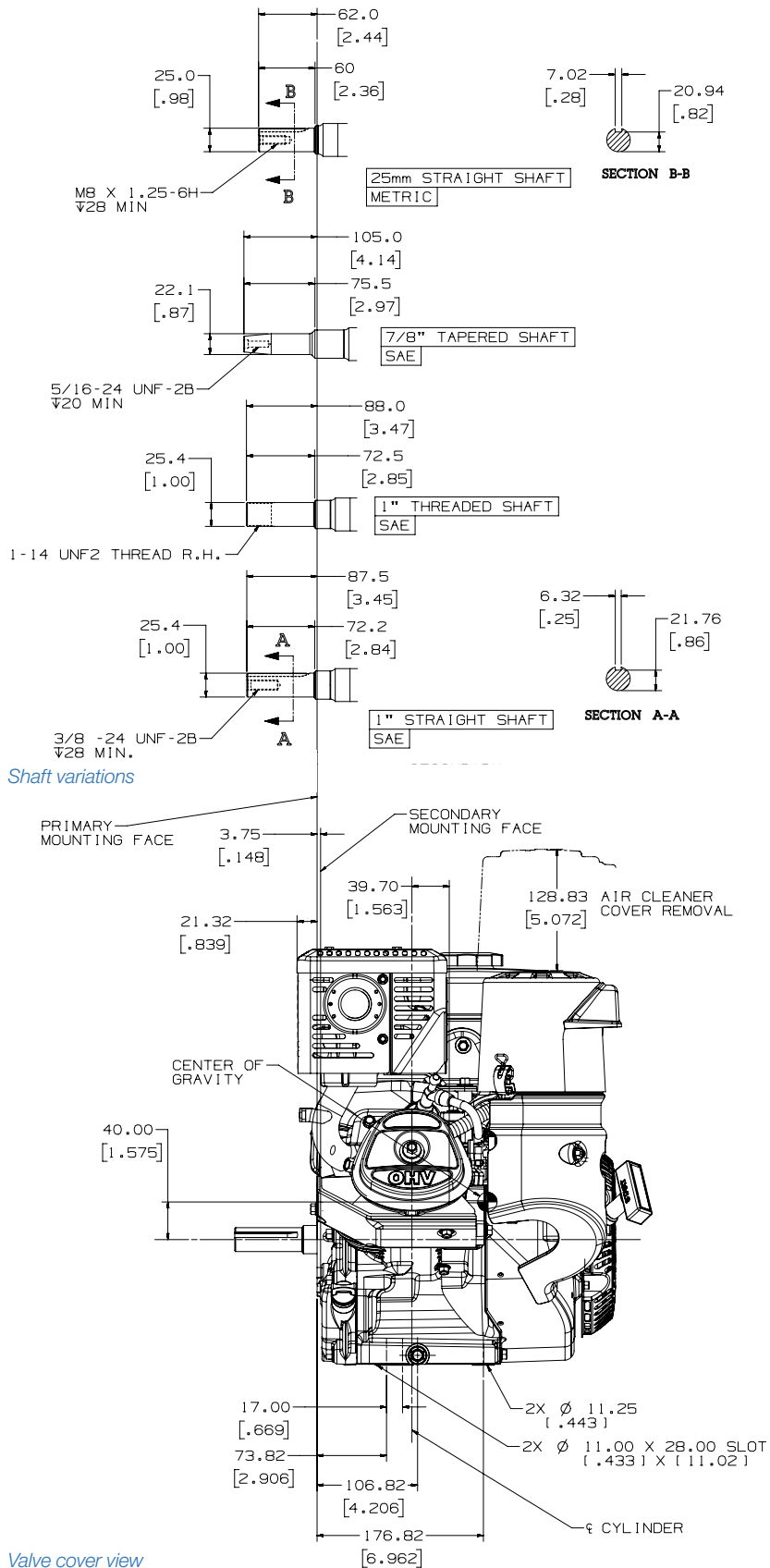

Shaft variations

Valve cover view

### MAXIMUM POWER

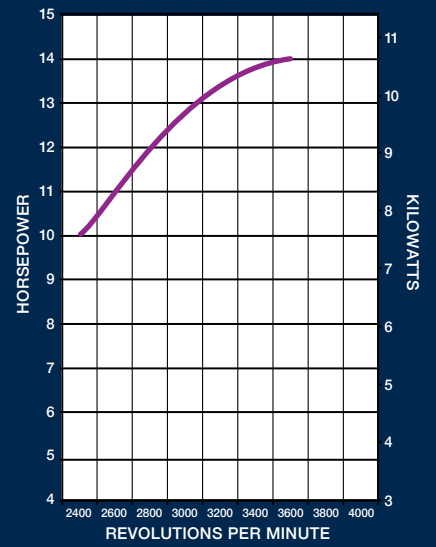

### MAXIMUM TORQUE

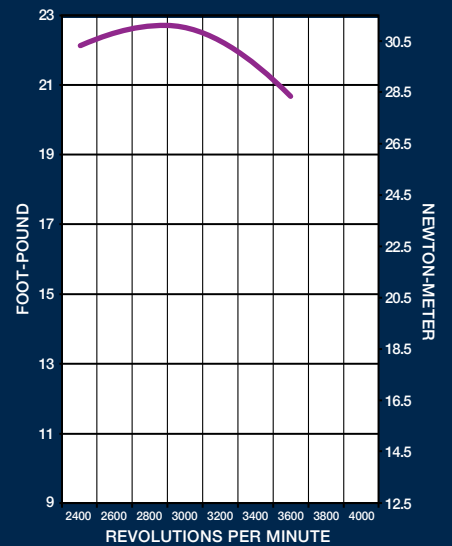

# FEATURES AND OPTIONS



CH395



ENGINE TYPE		Four-cycle, single-cylinder, overhead valve, air-cooled, gasoline, horizontal shaft, aluminum head and crankcase with cast-iron cylinder liner.			
MODEL		CH260	CH270	CH395	CH440
GROSS POWER @ RPM*	Max. hp (kW)	6 (4.5) @ 4000	7 (5.2) @ 4000	9.5 (7.1) @ 4000	14 (10.5) @ 3600
DISPLACEMENT	cu in (cc)	12.7 (208)		16.9 (277)	24.7 (429)
BORE	in (mm)	2.8 (70)		3.1 (78)	3.5 (89)
STROKE	in (mm)	2.1 (54)		2.3 (58)	2.7 (69)
PEAK TORQUE @ RPM	ft-lb (Nm)	10.4 (14.1) @ 3000	10.5 (14.2) @ 3000	13.9 (18.8) @ 2800	22.7 (30.8) @ 2800
COMPRESSION RATIO		8.8:1			8.3:1
DRY WEIGHT (RECOIL START)	lb (kg)	38.7 (17.5)		61.5 (27.9)	72.8 (33.0)
OIL CAPACITY	U.S. qt (L)	0.6 (0.6)		1.4 (1.3)	
FUEL CAPACITY	U.S. qt (L)	4.2 (4.0)		7.4 (7.0)	
LUBRICATION		Splash			
DIMENSIONS <sup>=</sup> L x W x H	in (mm)	10.3 x 15.2 x 15.1 (260 x 385 x 384)		12.4 x 17.8 x 16.8 (315 x 452 x 428)	12.7 x 17.8 x 18.4 (324 x 452 x 467)
CRANKSHAFT HEIGHT	in (mm)	4.2 (106.0)		5.3 (133.5)	

\*Horsepower ratings exceed Society of Automotive Engineers Small Engine Test Code J1940. Actual engine horsepower is lower and affected by, but not limited to, accessories (air cleaner, exhaust, charging, cooling, fuel pump, etc.), application, engine speed and ambient operating conditions (temperature, humidity and altitude). For more information, contact Kohler Co. Engine Engineering. Kohler reserves the right to change product specifications, designs and equipment without notice and without incurring obligation.

<sup>=</sup>Length is recoil starter to PTO mounting face. Height is with the USA 50 state evap fuel cap.



## STANDARD FEATURES

Quad-Clean™ heavy-duty cyclonic air cleaner	Large-capacity muffler with heat shield and spark arrestor	Stellite®-faced exhaust valve	Sound-deadening alloy crankcase
Built-in warm-air system for winter operation	CARB Tier 3 certified	Carbon canister fuel cap	Carburetor bowl drain
OHV slant cylinder	Increased displacement	Water trap to separate moisture in fuel	High-inertia flywheel
Cast-iron cylinder liner	Balance shaft (14 hp)	Swirl-induction combustion chamber	Silenced air intake
Large capacity metal fuel tank	Dual ball bearings	Easy-access throttle, choke and fuel shutoff	Indexable Easy-Pull™ recoil starter
Three fuel filters: fill neck, in-tank and carburetor inlet	Steel-forged-and-hardened crankshaft	Automatic compression release	Fuel Secure™ auto fuel shutoff (basic recoil specs only)
Electronic ignition	Dual oil fills and drains	Mechanical governor	3-year commercial limited warranty
	Automatic low oil engine shutdown system		

## POPULAR FACTORY OPTIONS

2:1 gear box (7 hp)	Crankshaft/PTO variations	EMC and Canadian RFI standards	Extended oil fill
2:1 with clutch gear box	No load idle solenoid for fuel economy	EU emissions and noise compliance	Remote throttle
6:1 gear box	Remote throttle	EPA Phase III compliance	Remote choke
High-altitude kits	Carburetor shutdown solenoid	Exhaust deflector	Electronic governor
12-volt starter	Balance shaft 9.5 hp	Low-profile air cleaner	Pulse pump
Exhaust deflector	In-line fuel filter	Low-profile muffler	Purge port for Quad-Clean air cleaner
3-, 10- or 18- (9.5- and 14-hp) amp charging			Tri-fuel capable





“

**MY KOHLER ENGINES  
START FIRST-PULL  
EVERY TIME  
AND THAT'S THE BEST  
YOU CAN ASK FOR.**

AL KINSEY, Owner  
Madison Rentals

”

**EUROPE**

Lombardini Srl  
Via Cav. del lavoro  
A. Lombardini n° 2  
42124 Reggio Emilia, ITALY  
T. +39-(0)522-389-1  
infodiesel@kohler.com

**DEUTSCHLAND**

Lombardini Motoren GmbH  
Fritz-Klatte-Str. 6, Bürogebäude 2  
65933 Frankfurt am Main,  
DEUTSCHLAND  
T. +49-(0)69-9508160  
de.infodiesel@kohler.com

**UK**

Lombardini U.K. Ltd  
1, Rochester Barn - Eynsham Road  
OX2 9NH  
Oxford, UK  
T. +44-(0)1865-863858  
uk.infodiesel@kohler.com

**ESPAÑA**

Lombardini ESPAÑA, S.L.  
P.I. Cova Solera 1-9  
08191 - Rubí (Barcelona)  
ESPAÑA  
T. +34-(0)9358-62111  
es.infodiesel@kohler.com

**FRANCE**

Lombardini France S.a.s.  
47 Allée de Riottier,  
69400 Limas, FRANCE  
T. +33-(0)474-626500  
fr.infodiesel@kohler.com

**ROAPAC**

Kohler Singapore Pte Ltd  
(Kohler Power Systems)  
7 Jurong Pier Road  
SINGAPORE 619159  
T. +65-63020701  
Sgsalesall@kohler.com

Kohler Engines is a brand distributed by Lombardini s.r.l., part of Kohler Group.  
Lombardini has manufacturing facilities in Italy, Slovakia and India and sales subsidiaries in France, Germany, UK, Spain and Singapore.  
Kohler/Lombardini reserve the right to make modifications without prior notice. For the latest version please visit our website:

**KOHLERENGINES.COM/EU**

**KOHLER**  
IN POWER. SINCE 1920.