



MEGA

eWORKER

Dear Customer,

*You have just picked up your new **MEGA** and we thank you for your trust.*

***MEGA** vehicles are designed to offer you the highest satisfaction in using them, and our network of approved dealers is available to provide you with the best service.*

Before using your vehicle, please read the maintenance program, warranty conditions as well as the explanations contained in this manual, which will allow you to get acquainted with your new vehicle.

Observing the following four important safety rules will ensure you and your passengers drive safely:

- *Never drive under the influence of alcohol, medicine or drugs.*
- *Always observe the speed limits indicated and never drive faster than allowed by traffic conditions.*
- *Always wear your seatbelt and use appropriate retaining devices for children.*
- *Always inform your passengers of the proper use of the safety devices.*

Have a safe trip.
MEGA
After-sales service

CHARACTERISTICS OF THE VEHICLE

I declare having received the vehicle which serial number is specified here in an impeccable state.

Client signature: _____

Serial no.: _____

Motor no.: _____

Reducer No.: _____

Registration no.: _____

Date of first registration : _____

Vehicle owner: _____

Street and No.:

Postal code: _____

City : _____

Telephone: _____

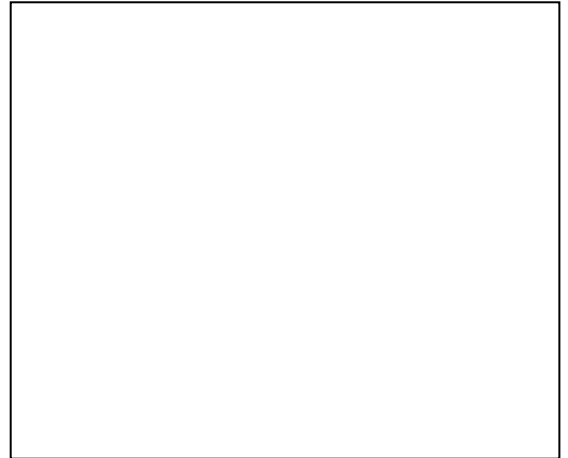

CONTENTS

GENERAL INFORMATION

- Characteristics of the vehicle 1
- Contents..... 2
- Vehicle identification..... 3 to 5
- Foreword and Safety.....6 to 13
- Technical characteristics.....14 to 19
- Checks before delivery 19
- Training.....20
- Checks to be performed by the user 20
- Checks upon servicing..... 21,22
- Servicing program.....23 to 25
- Lubricant and quantity..... 26

USER MANUAL

- Cab25 to 31
 - Opening, closing doors
 - Seats
 - Safety belts
- Instrumentation32 to 45
 - Onboard instruments
 - Other indicators
 - Left control
 - Right control
 - Inside lighting
 - Central dashboard controls
 - Additional heating (option)
 - Emergency stop
 - Hour meter (option)

- Driving
 - Recommendation for break-in.....46 to 50
 - Ignition
 - Forward/reverse selector
 - Parking brake
 - Recommendations
- Charging the Vehicle50 to 53
- Storing the vehicle.....54
- Safety related with the batteries54
- Cleaning the vehicle55 to 56

CHECKS AND SERVICING

- Tires 57
- Opening the hood and lateral tool chests..57
- Accessory battery..... 58
- Changing fuses 59
- Changing lamps 60
- Levels.....61 to 62
- Road call-towing..... 63
- Loading 64
- Troubleshooting65 to 67

VEHICLE IDENTIFICATION

The regulatory plates and inscriptions are located outside the vehicle, on the stringer behind the rear right wheel on short and long versions.

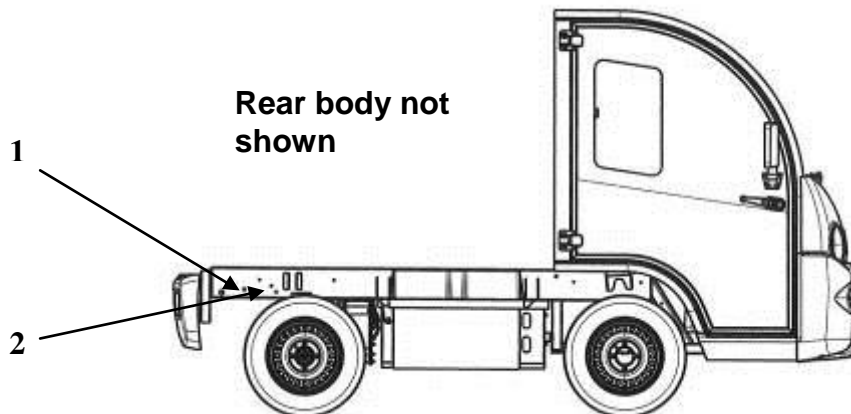

1 : The serial number is cold punched, and is composed of 17 characters and 2 closing stars.

VLGXXXXXXY000001

Structure of the serial no.:

VLG = manufacturer code

XXXXXX = type, variant, version

Y = assembly unit

000001 = order number

2 : The manufacturer plate is fastened by two rivets.



We remind you that altering markings and identifications may result in penal sanctions

- Information on the manufacturer plate of the **machine** version:

AIXAM-MEGA	= Manufacturer
VLGXXXXXXXXY0000001	= Serial number
xxxx Kg	= Maximum allowable loaded weight
xxxx Kg	= Maximum allowable driving weight (with trailer)
1- xxxx Kg	= Maximum weight technically allowable on the front axle
2- xxxx Kg	= Maximum weight technically allowable on the rear axle

- Information on the manufacturer plate of the **quadricycle** version:

AIXAM-MEGA	= Manufacturer
e2*2002/24*xxxx	= authorization number
VLGXXXXXXXXY0000001	= Serial number
xx dB(A)	= sound level
xxxx rpm	= Nominal motor speed



**Never remove the information plate, warnings nor instructions fastened on the MEGA vehicle.
Change them promptly when damaged or disappeared.**

MACHINE LOAD TAG

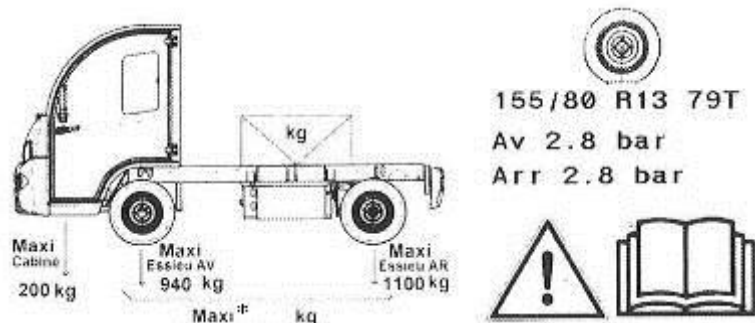

* depends on the version chosen – see weight table

CE MACHINE CONFORMITY TAG

AIXAM-MEGA

56 route de Pugnay

F-73101 AIX-LES-BAINS



Puissance: 10 kW

Tension traction: 72V

Tension service: 12V

Désignation et marque: Chariot porteur MEGA

Type-version: xxxxxxxx

Masse à vide: yyy kg

Masse Maximale: z zzz kg (avec remorque: 2 525 kg)

Année: 201x

RISK IDENTIFICATION TAGS



CAUTION DANGER, SAFETY INSTRUCTIONS



READ THE INSTRUCTION MANUAL



DANGER PRESENCE OF LIVE VOLTAGE
**NEVER ATTEMPT TO ACCESS ALL OR PART OF THE VEHICLE
REQUIRING TO USE TOOL**



RISK OF GASES GENERATED BY THE BATTERIES

La zone de rechargement des batteries doit être correctement ventilée : risque de dégagement d'hydrogène.
Während des aufladens der batterie muss ordentlich gelüftet werden, da wasserstoff austreten kann.
The recharging area for the batteries must be correctly ventilated : risk of hydrogen gases.
La zone di ricarica delle batterie deve essere adeguatamente ventilate : rischio di fuga d'idrogeno.
La zona de recarga de la bateria tiene que ser correctamente ventilada : riesgo de fuga de hidrogeno.

BATTERY RECHARGING



RISKS OF EXPLOSION (HYDROGEN)

NAKED FLAMES, SPARKS (SHORT-CIRCUIT) OR INCANDESCENT MATERIALS ARE FORBIDDEN IN THE BATTERIES ZONE



DANGER CORROSIVE MATERIALS (acid)

IN CASE OF CONTACT WITH THE EYES OR SKIN, WASH THOROUGHLY WITH WATER. REFER TO A DOCTOR IMMEDIATELY



NAKED FLAME FORBIDDEN



HOT ZONE



WEAR PROTECTION GLASSES AND CLOTHING



WEAR YOUR SEATBELT

FOREWORD

Your vehicle offers the best in terms of savings, reliability and comfort. You must maintain its qualities over time to enjoy its performance as long as possible.

This instruction and maintenance manual, also named user manual or instruction manual will provide you with important information, advice and warnings on transporting, starting up, driving and maintaining your MEGA.

This manual defined the purpose for which this vehicle was built for, and contains all the information required to guarantee proper use and environmental protection.

Total and constant application of the indications contained in this technical document guarantees safety both of the person and vehicle, the best running savings and longer lifetime, and therefore this manual should be read carefully before the first use of the vehicle.

The photographic documentation and drawings are supplied as examples to ensure complete description of the operations to be performed on the vehicle.

This manual was written by the **AIXAM- MEGA** company, and is fully part of the vehicle, and must be stored in the vehicle at all times. The absence of this manual on board the vehicle may result in cancelling the warranty.

Observe the warnings and perform regular inspections and servicing at the planned times and mileages.

We advise you to have maintenance performed only by **AIXAM MEGA** specialized and approved personnel and, in any case, observe the indications in this manual.

We also recommend to scrupulously observe any standards related with prevention of occupational accidents and the traffic code.

The driver is liable for any danger caused by observing other provisions, and if applicable, must put forward any circumstances which may result from the manufacturer **AIXAM MEGA**. This vehicle is used for transportation of goods or persons. These operations must be led within compliance with the allowable capacity limits indicated in this document.



WARNING: this manual must be stored on board the vehicle et available at all times for all users.



This symbol  indicates to refer to the use manual.

AIXAM MEGA may not be held liable for the consequences of any modification of the vehicle made without its approval.

The **AIXAM MEGA** company constantly improves its products. Therefore, we reserve the right to make any technical modifications aiming at improving the product.

Even if your vehicle does not correspond to the illustrations contained in this document, safety and the information on the vehicle remain guaranteed.

We also shall update the documentation, but the indications and technical data will in no event be final and cannot be used for claims or compensation in general.



WARNING

This manual describes only **routine** servicing. For **recommended maintenance**, always refer to a MEGA approved dealer.

If you encounter mismatches or differences in the equipment, please call upon your MEGA approved dealer for any instructions in this respect.

Please also call upon the after-sales service of your MEGA approved dealer for any problems related with your MEGA or to acquire spare parts.

Parts not made by MEGA may damage the vehicle, so use only MEGA original parts and the consumables recommended. This will ensure you maintain its characteristics over the years.

Before leaving our company, your vehicle has been scrupulously checked to guarantee it is delivered to you with the full equipment compliant with your order.

Our MEGA approved dealer must perform the pre-delivery checks and deliver your vehicle within the deadline set. Please check that your vehicle is in perfect condition and has all the equipment planned.

Each vehicle is supplied with an instruction manual.



SAFETY STANDARDS

It is indispensable to know the content of this manual, which must be available to persons authorized to drive the vehicle at all times, for the SAFETY STANDARDS to be considered when using and servicing the vehicle.

SAFETY FIRST



The safety warning symbol is used in this manual and on stickers applied to the vehicle to warn about potential injury.

Read these instructions carefully. These safety instructions and rules must be read before attempting to repair or use this vehicle.



DANGER:

indicates an imminent dangerous situation which, if not avoided, will cause severe or even lethal injury.



WARNING:

indicates a potential dangerous situation which, if not avoided, may cause severe or even lethal injury.



CAUTION:

indicates a potential dangerous situation which, if not avoided, may cause light or medium injury.

CAUTION: AVOID RISKS OF FIRE AND EMISSION OF NOXIOUS GASES FROM THE BATTERIES

- Never alter the vehicle's integrity. Do not modify the vehicle. Do not drill, puncture, heat, cut, unscrew, remove, deform any part of the vehicle.
- The batteries are located at the centre of the vehicle. They are distributed into 3 battery trays protecting them from the outside environment.

Any aggression involving penetration of a foreign body into the batteries or distortion of the batteries may start a fire and an emission of noxious gases.

During a fire lead/acid accumulator batteries do not burn, or burn with difficulty. Do not use water in fires where melting metal is present. Put off fires with an appropriate agent to surround combustible materials. Cool the outside of the battery if it is exposed to fire to avoid breakage. Acid mist and vapours generated by heat or the fire are corrosive. Use an autonomous respiratory apparatus approved by and full protection equipment used in positive pressure mode.

Sulphuric acid vapours are generated upon overload and failure of the polypropylene envelope. Use appropriate ventilation. Avoid naked flames / sparks / other ignition sources close to the battery.

MEASURE AGAINST RISKS OF EXPLOSION

Hydrogen vapours are emitted during charging. These battery gases may explode in case of strong accumulation.

Also, always hold sparks, flames and cigarettes away from the top of the battery, particularly during its charging and maintenance.

Ventilate the charging zone properly to avoid any risk of explosion. The volume of air to extract from the charging zone must exceed 15 m³ per hour and per vehicle.

MEASURES AGAINST ACID BURN

Sulphuric acid of the battery electrolyte is toxic. It is sufficiently concentrated to burn skin or clothing, as well as to cause blindness when splashed in the eyes. Maintain the electrolyte away from your eyes, hands, and clothing. If splashed with the electrolyte, rinse with fresh water and call a doctor.

For any intervention on a battery, wear glasses and gloves.

MEASURES IN CASE OF ACCIDENTAL SPILL

Cleaning procedures. Avoid any contact with the spilled substance. Contain the spill, isolate the dangerous zone and refuse entry. Restrict access to the site to emergency interveners. Neutralize with sodium bicarbonate, Soda bicarbonate, Lime or other neutralizing agents. Place the battery in an appropriate container for disposal. Eliminate contaminated materials in compliance with local, state and federal regulations applicable. Sodium bicarbonate, soda bicarbonate, sand, lime or other neutralisation agents must be stored on site to clear up spills.

BE READY FOR EMERGENCIES

- Ensure a first aid kit, a fire extinguisher, a warning triangle and a safety vest are available at all times.
- Keep close to your phone the numbers of doctors, and ambulance service, a hospital and the fire brigade.

SAFE STARTING

Before any use, the user must check it will be able to drive safely.

Any unauthorized modification may be detrimental to the vehicle's operation and/or its safety, as well as its lifetime.









Driving in rough paths or off road is forbidden.

The vehicle must be used on roads prepared, designed and built for motor vehicle traffic.

YOUR VEHICLE BELONGS EITHER TO THE MACHINE OR QUADRICYCLE CATEGORY. Access to public roads is possible only if your model carries a road homologation, a registration and the driver holds the driving authorizations required.

- **MACHINE:** In some countries the machine homologation is not a public road homologation. Before driving in your country, please check you have the appropriate driving authorizations.

- **QUADRICYCLE: HERE IS THE LIST OF ROADS FORBIDDEN TO QUADRICYCLES*:**

-  - Traffic forbidden to any vehicle in both directions.
-  - No entry to all vehicles.
-  - No entry for mopeds and quadricycles.
-  - No entry to all motor vehicles.
-  - Bicycle path or lane forbidden to quadricycles.
-  - Bus lane.
-  - Road for automobiles forbidden to quadricycles.
-  - Motorway entrance forbidden to quadricycles.
-  - Right turn forbidden to mopeds and quadricycles.
-  - Direction forbidden for mopeds and quadricycles.
- 

* the signs presented are valid only for France

SAFETY RULES

- Do not transport persons in the part reserved to the load.
- Do not leave the keys on the ignition during the absence of the driver.
- In case of rain, fog, snow, the driver must use the wipers and light and indicator devices, as well as the windshield demisting/defrosting system.
- In case of breakdown, park your vehicle in a clear area and warn other drivers using the warning and position lights. Also apply the parking brake and activate the emergency stop palm switch on the dashboard. Put on your safety vest and place the warning triangle on the road. The user will equip the vehicle with as many vests and triangles as set by the legislation of the driving country.
- Both the driver and passenger must leave the vehicle and stand in a secured zone at a proper distance.

BEFORE SERVICING AND REPAIRING



An authorization is necessary to intervene on the vehicle's 72V network.

- Carefully read the safety instructions and guidelines contained in this manual and on the safety stickers fixed to the vehicle.
- Clean the working surface and the vehicle.
- Park the vehicle on firm and flat ground. Materialize and protect the intervention zone from any non authorized person.
- Let the vehicle cool down before any intervention.
- Remove the ignition key.
- Disconnect the negative cable from the accessory battery.
- Cut the circuit of the traction batteries using the palm switch circuit breaker on the dashboard and the power connector located on the speed controller plate.
- Hang a **DO NOT START** sign on the operator station.
- Before operating on the batteries, move away any metallic objects on your hands, wrists, neck or likely to fall from your pockets. Always use insulated tooling. Do not place tools or other conductors on the battery elements.

RECYCLING BATTERIES

Traction batteries must be collected and recycled by professionals of waste hazardous for the environment. Never throw a battery in household waste or abandon it in the wild.

TECHNICAL CHARACTERISTICS

Drive wheels	Rear drive					
DIMENSIONS (mm)	Short chassis			Long chassis		
Front track width	1 045					
Rear track width	1 045					
Average wheelbase	1 471			1 971		
Front overhang	1 089					
Min/max rear body overhang	605 / 815					
Min/max body length	3 165 / 3 375			3 665 / 3875		
Overall width (cab chassis version)	1 200 (without doors) - 1 272 (with doors)					
Max body width	1 360					
Cab height (excluding options)	1 895 +/- 25					
Max body height	2 500					
Limit position of the load centre of gravity in respect of the front axle shaft: min/max	1 000 / 1 400	1 000 / 1 400	1 000 / 1 400	1 150 / 1 700	1 150 / 1 700	1 150 / 1 700
WEIGHT (kilograms)	Short cab chassis without 8.6 kWh battery holder	Short cab chassis without 11.5 kWh battery holder	Short cab chassis without 17.3 kWh battery holder	Long cab chassis without 8.6 kWh battery holder	Long cab chassis without 11.5 kWh battery holder	Long cab chassis without 17.3 kWh battery holder
HEAVY QUADRICYCLE CATEGORY (2002/24/CE L7e)						
Gross vehicle weight rating	1 640					
Max allowable load on front axle	940					
Max allowable load on rear axle	1100					
Empty vehicle curb weight:						
Total	768	833	999	778	843	1 009
On front axle	467	498	576	436	459	517
On rear axle	301	335	423	342	384	492
Payload (excluding driver, passenger, equipment and cargo)	872	807	641	862	797	631
Authorized gross vehicle weight (without cab doors)	1 880			1885		
Authorized gross vehicle weight (with cab doors)	1 900			1 905		
Maximum towed weight (braked or not) (without cab doors)	240			245		
Maximum towed weight (braked or not) (with cab doors)	260			265		
EQUIPMENT WEIGHT (to be deducted from the payload)						
Cab doors	40					
Drop side	73			88		

TECHNICAL CHARACTERISTICS (cont'd)

Standard 1-curtain van	101			127		
Per additional curtain				12		
Tipper	124			145		
Additional heating tank full 9l				22		
Rear protection bar				10		
Trailer hitch				15		
WEIGHT (kilograms)	Short cab chassis without 8.6 kWh battery holder	Short cab chassis without 11.5 kWh battery holder	Short cab chassis without 17.3 kWh battery holder	Long cab chassis without 8.6 kWh battery holder	Long cab chassis without 11.5 kWh battery holder	Long cab chassis without 17.3 kWh battery holder
MACHINE CATEGORY						
homologated directive on machinery 2206/42/CE						
Gross vehicle weight rating	1 640	1 700	1 700	1 700	1 772	1 772
Max allowable load on front axle	940					
Max allowable load on rear axle	1 100					
Empty vehicle curb weight:						
Total	768	833	999	778	843	1 009
On front axle	467	498	576	436	459	517
On rear axle	301	335	423	342	384	492
Payload (excluding driver, passenger, equipment and cargo)	872	867	701	922	929	763
Gross driving weight rating	2 525					
Maximum tow weight (brake) within the limit of the AGVV	1 425					
Maximum tow weight (non braked)	750					
EQUIPMENT WEIGHT (to be deducted from the payload)						
Cab doors	40					
Drop side	73			88		
Standard 1-curtain van	101			127		
Per additional curtain				12		
Tipper	124			145		
Additional heating tank full 9l				22		
Rear protection bar				10		
Trailer hitch				15		

TECHNICAL CHARACTERISTICS (CONT'D)

MOTOR	Heavy quadricycle	Machine
Brand	LEROY SOMER	
Technology	Asynchronous	
Maximum power (kW CE)	10 kW S2-45' at 3 200 rpm	
Motor regulation speed (rpm)	5 950	3 750
Motor cooling	Air turbine	
TRACTION BATTERY		
Technology	Lead traction battery – 36 elements of 2V in series	
Theoretical energy on board at C/5 and 25°C	8.6 kWh / 11.5 kWh / 17.3 kWh	

TECHNICAL CHARACTERISTICS (CONT'D)

MOVEMENT TRANSMISSION

- Control mode: automatic
- Transmission type:
Motor → differential regulator bridge → wheels.

Maximum speed

- machine version: 25 km/h
- quadricycle version: 40km/h

OPERATING CAPACITY

- empty slope: ≤ 25 %
- loaded slope: ≤ 15 %
- Superelevation: e-Worker must not be driven on tracks with a superelevation > 10 %

SUSPENSION

- Front:
Independent wheels, pseudo Mac Pherson type, double effect hydraulic telescopic shock absorbers and helical springs.
- Rear:
Rigid axle, double effect hydraulic telescopic shock absorbers and leaf springs.

STEERING

- Steering type: rack

BRAKING

- Service brake

CHARACTERISTICS	FRONT	REAR
Type	Discs	Drums
Diameter	220 mm	160 mm

The front and rear linings are driven by hydraulic pistons controlled by a double circuit master cylinder. This master cylinder supplied by a brake fluid tank is controlled from inside the vehicle by a pedal within reach of the driver's right foot. A restrictor controlled by the load ensures automatic reduction of braking power on the rear train.

- Emergency brake and parking brake
A lever located near the driver's right hand, between both vehicle seats, actuates the rear brakes, by means of a cross-bar with two cables. This brake is adjusted mechanically by a screw on the level of each rear wheel or the cross-bar. A pawl allows to hold this brake in the applied position.



In case of failure of the service brake (e.g. soft pedal), use the emergency brake and call an approved repair shop.

TECHNICAL CHARACTERISTICS (CONT'D)

BODY:

- Materials making up the body:
 - Thermoformed ABS and glass fibre reinforced polyester
- Number of seats: 2
- Seats: 2
- Number of doors: 2 (option)
- Nature of materials used for windows:
 - Windshield: laminated glass
 - Side windows: tempered glass
 - Rear window: tempered glass

LIGHTING AND SIGNALING

- Headlights:
 - indicators: 12V/21W
 - position lights: 12V/21W
 - low and high beam 12V/50W/60W
- Rear lights:
 - rear and stop lights: 12V/5W/21W
 - indicator: 12V/21W
 - reverse: 12V/21W
 - fog: 12V/21W
- Registration plate light: 12V/5W

PRE-DELIVERY CHECKS

After all the care given to the construction of your MEGA vehicle, your approved dealer applies a check-list to ensure you fully enjoy your new vehicle.

- Check of closing and locking of all closing panels (doors, windows, hood, rear doors / curtain, storage compartments,....)
- Check of onboard tooling, including warning lamps
- Check of cable integrity and recharging, as well as earth continuity. Anti-start check
- Level check:
 - reducer axle oil
 - washer fluid
 - brake fluid
 - charging level of traction batteries and accessories battery
 - electrolyte level traction batteries
- Check sealing of the brake circuit
- Tire pressure check
- Check tightening of wheels, ball joints, engine, electric power circuit, reverser bridge and screws in general.
- Check operation of electrical and lighting devices. Full charging of traction batteries.
- Check of parallelism.
- Vehicle test.
- Cleaning the vehicle interior and exterior

TRAINING

Upon key handover and to allow you to enjoy your vehicle in the best possible conditions, your Mega dealer must train you (as well as any potential user of the vehicle) in the operation and rules to be applied rigorously.

An electric vehicle requires prior training, as its use imposes a behaviour different from that applicable with a thermal vehicle.

CHECKING AND SERVICING TO BE PERFORMED BY THE USER

1. Daily checking:

- Pressure and condition of the tires.
- Seatbelt operation check
- Handbrake operation check
- Horn operation check

2. Weekly check:

- Brake fluid level check.
- Vehicle full charging (the charging lamp must be lit steady upon ignition)
- Topping up battery electrolyte (as per the indications of the filling lamp and user manual instructions – see appropriate chapter)
- Lights and signaling operation check.
- Instrument panel lamp check.
- Check of the condition of the cable, vehicle charging plug and 220V mains charging plug.
- Wiper fluid level check.
- Vehicle general condition check.

SERVICING PROGRAM (by a MEGA PRO approved dealer)

INTERVENTIONS AND CHECKS TO PERFORMED UPON SERVICING	First servicing between 500 km and 1000 km or 3 months*	Battery maintenance every month	Inspection visit every 6 months	Servicing at 2,500 km or 1 year and every 2,500 km*
Empty and change reducer oil	o			o
Oil level check in the reducer (top up if necessary)			o	
Check of the level of brake fluid (top up if necessary)**	o			o
Check sealing of the brake circuit	o			o
Check operation of the brakes including the handbrake	o		o	o
Clean and remove dust from the brakes, change the pads if required				o
Check the DC/DC converter as well as the voltage and electrolyte level of the accessories battery, top up with demineralised water if required.			o	o
Perform a discharge test of the accessories battery. Change it if required.				o
Check tightening of the jumper cables between battery elements	o	o	o	o
Check the condition of the battery trays and lack of acid leaks	o	o	o	o

* at first term reached

**The brake fluid must be changed every year

INTERVENTIONS AND CHECKS TO PERFORMED UPON SERVICING	First servicing between 500 km and 1000 km or 3 months*	Battery maintenance every month	Inspection visit every 6 months	Servicing at 2,500 km or 1 year and every 2,500 km*
Full charging of traction batteries	o		o	o
Clean and wipe each battery elements (any traces of acid deposits)		o	o	o
Check if watering system is not pinched or blocked, check the electrolyte level of each traction battery element and top up if necessary	o	o	o	o
Measure idle voltage after charging and acid content of the cells			o	o
Remove dust from the electric components plate and check cable tightening				o
Check the condition of the charging cable and vehicle charging connector	o		o	o
Check the earth connection and isolation	o		o	o
Check errors thanks to diag tools DT-AM / Provista			o	o
Check tightening of the screws (wheels, motor,...)	o		o	o
Check tire pressure	o		o	o
Check sealing of shock absorbers				o
Check leaf springs tightening torque	o		o	o
Check condition of suspension pins (motor, reducer)				o
Check the condition of the bellows (joints and steering rack)				o
Check proper operation of the lighting and electric instrumentation and adjustment of headlights	o			o
Check and adjust parallelism	o			o
Test drive the vehicle	o			o



Servicing work to be performed yearly (in addition to recommended maintenance):

- change the braking circuit fluid.
- change the wiper blades

It is **STRICTLY FORBIDDEN** to remove the protection cover on the electric base plate and more generally to remove any part on the vehicle requiring the use of a tool.

This table is based on a vehicle running in standard conditions. In case of a more constraintful use or environment, the frequency of the operations must be increased (please call).

Servicing 500/1000 km or 3 months

Date : [][] [][] [][]
Day month year

Mileage: [][] [][] [][]

LABOUR FREE

Approved dealer stamp and signature

Servicing 7,500 km or 1 year

Date : [][] [][] [][]
Day month year

Mileage: [][] [][] [][] [][]

Approved dealer stamp and signature

Servicing 2,500 km or 1 year

Date : [][] [][] [][]
Day month year

Mileage: [][] [][] [][] [][]

Approved dealer stamp and signature

Servicing 10,000 km or 1 year

Date : [][] [][] [][]
Day month year

Mileage: [][] [][] [][] [][]

Approved dealer stamp and signature

Servicing 5,000 km or 1 year

Date : [][] [][] [][]
Day month year

Mileage: [][] [][] [][] [][]

Approved dealer stamp and signature

Servicing 12,500 km or 1 year

Date : [][] [][] [][]
Day month year

Mileage: [][] [][] [][] [][]

Approved dealer stamp and signature

Servicing 15,000 km or 1 year

Date : [][] [][] [][]
Day month year

Mileage: [][][][][][]

Approved dealer stamp and signature

Servicing 17,500 km or 1 year

Date : [][] [][] [][]
Day month year

Mileage: [][][][][][]

Approved dealer stamp and signature

Servicing 20,000 km or 1 year

Date : [][] [][] [][]
Day month year

Mileage: [][][][][][]

Approved dealer stamp and signature

Servicing 22,500 km or 1 year

Date : [][] [][] [][]
Day month year

Mileage: [][][][][][]

Approved dealer stamp and signature

Servicing 25,000 km or 1 year

Date : [][] [][] [][]
Day month year

Mileage: [][][][][][]

Approved dealer stamp and signature

Servicing 27,500 km or 1 year

Date : [][] [][] [][]
Day month year

Mileage: [][][][][][]

Approved dealer stamp and signature

Servicing 30,000 km or 1 year

Date : [][] [][] [][]
Day month year

Mileage: [][][][][][]

Approved dealer stamp and signature

Servicing 32,500 km or 1 year

Date : [][] [][] [][]
Day month year

Mileage: [][][][][][]

Approved dealer stamp and signature

Servicing 35,000 km or 1 year

Date : [][] [][] [][]
Day month year

Mileage: [][][][][][]

Approved dealer stamp and signature

Servicing 37,500 km or 1 year

Date : [][] [][] [][]
Day month year

Mileage: [][][][][][]

Approved dealer stamp and signature

Servicing 40,000 km or 1 year

Date : [][] [][] [][]
Day month year

Mileage: [][][][][][]

Approved dealer stamp and signature

Servicing 42,500 km or 1 year

Date : [][] [][] [][]
Day month year

Mileage: [][][][][][]

Approved dealer stamp and signature



MEGA

Recommends the use of synthetic oils

REDUCER (oil 100% synthetic 80W90)

0.8 litre

BRAKE FLUID (DOT4):

0.3 litre

CAB

If the vehicle is not fitted with the door option, the driver and passenger must buckle their seatbelt and keep their lower and upper limbs inside the cab at all times.

Do not stand outside.



FRONT DOORS (option)

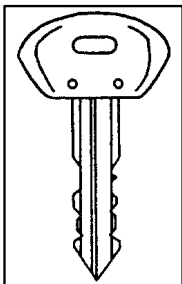

KEYS

Four keys are supplied: two keys for starting ignition, two keys for door locks. Keep one of each in a safe place as spare key. Other keys may be supplied according to the version.

UNLOCKING FROM INSIDE THE VEHICLE



1. Lift the lever

CLOSING THE DOOR FROM THE INSIDE

To close, grip the door handle and pull it shut. **Always check the door is properly closed before driving off.**

Removable doors (option):
Refer to the specific user manual



Before opening the door or leaving the vehicle, always check that this operation does not cause a risk for other users near the vehicle, and there is enough room to open the door without hitting it.



SLIDING WINDOWS

To open the windows of the front doors, use the appropriate bolt on the front of the sliding window.



If your vehicle does not have doors, beware all outside elements (branches, flexible curtain blades, snow, water,...) likely to enter the cab.

INSIDE REAR VIEW MIRROR

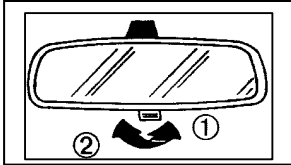

The lever located on the lower part can be used to reduce glare from the lights of follower vehicles during night driving.

1. Normal
2. Anti glare



CAUTION

Before using the vehicle, always check the adjustment of the outside and inside mirrors to have proper rear vision from your driving station.



CAUTION:

Never drive with the rear stake hanging (stake platform, tipping bin model) as this would mask the rear lights.

Always ensure the load does not protrude and does not hide the registration plate and rear lights.

ADJUSTING THE SEATS



Adjust the driver's seat in a position ensuring easy actuation of the pedals, steering wheel and various dashboard controls.

To adjust the seat forward or back, lift the release bar. After adjusting, release the lever to lock the seat in position.

The driver seat is fitted with a safety seat switch. The latter is activated when you sit on the seat. Non-activation of this switch prevents the vehicle from starting.

HEADRESTS

Press the adjustment button and lower or raise the headrest to adjust it as required.

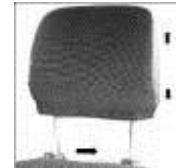

- Adjust the seat and headrest before starting off.
- After adjustment, check that the seat is locked in position.



- Driver and passenger must keep both feet on the floor and use the holding handles.

SEATBELTS



ALWAYS BUCKLE YOUR SEATBELTS

Three-point seatbelts with tensioner

This type of seatbelt does not require any length adjustment. Once buckled, the belt adjusts freely to user movements, but in case of strong or sudden shock, it locks automatically to hold your body.

Before buckling your safety belt, sit comfortably against the back of your seat, adjust its position according to the pedals.

When you buckle your seatbelt, push your back against the seat backrest. The thorax strap must be as close as possible to the neck, without pressing it. The hip strap must be laid flat on the thighs and against your hips.

The belt must bear on the body as directly as possible. Avoid thick clothing, embedded objects, ...



To buckle your belt, unwind the strap slowly and smoothly, and check the latch clicks in the housing. Check proper engaging by pulling the latch. If the strap is jammed before being engaged, let it wind back and unwind again



To unbuckle your seatbelt, press the red button on the housing, and the belt should be wound by the tensioner. Accompany the latch to facilitate the operation.

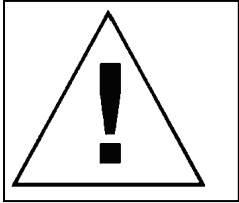

SEATBELTS

- Regardless of the time or distance of your trip, always wear your seatbelt.
- In addition, apply the local legislation of your country.
- The seatbelt was designed to hold one person only. Never carry a child on your knees and strap your seatbelt on.
- Never use a device likely to introduce play in the straps (e.g. clothespin, etc.) as a seatbelt worn too loose may cause injuries in case of accident.
- After a severe accident, always change the seatbelts which were used at the time. Also, if a seatbelt is damaged or frayed, it must be changed.
- Clean your seatbelts only with water and soap. Any other product is prohibited.
- Poorly adjusted seatbelts may cause injuries in case of accident. Pregnant women must wear their seatbelt. In this case, ensure the hip strap does not apply too much pressure on the stomach without creating additional play.
- When the seatbelt is worn, the straps must be flat.
- Do not move the hip strap under your arm or behind your back.
- The seatbelts were designed to be used by occupants with an adult size, measuring: over 1.50 metre tall and a weight above 36 kg.
- The vehicle is not homologated to use baby or child retaining systems
- Do not modify or transform the seatbelts, their anchors on the chassis or vehicle seats.
- Use only original manufacturer equipment.
- Babies or children should never be carried on the laps of vehicle occupants.
- Never use a single seatbelt to strap two persons at the same time.
- Never leave a child or animal inside a vehicle exposed to the sun with the windows closed.
- Never leave your keys within reach of children inside the vehicle.

INSTRUMENTATION

All electric components of your vehicle are supplied by an accessories battery.

This accessories battery is recharged by means of a converter using part of the energy available in the traction batteries during the operating phases. Accessory battery recharging is active only if the ignition key has been activated.

Connecting the vehicle to mains recharges the traction batteries, but not the accessories battery.

If the voltage of the accessories battery is too low, the vehicle will not start. Therefore, ensure you use the electric equipment properly and do not add electrical consumers not planned for by the manufacturer.

1. CONTROL PANEL



1. Warning lights indicator
2. Left turn indicator
3. Dual reading speedometer (external reading = kilometres per hour ; internal reading = miles per hour)
4. Right turn indicator
5. General fault indicator (stop immediately)
6. Power available indicator
7. Windscreen defrosting indicator:
8. Rear fog light indicator:
9. Heating seat indicator:
10. Parking brake and brake fluid level indicator
11. High beam indicator
12. *Non active*
13. Low beam indicator
14. Pad wear indicator
15. LCD DISPLAY
16. LCD display management button

CONTROL PANEL (cont'd)

POWER LEVEL INDICATOR

This needle gage indicates the level of energy remaining in the traction batteries.

Once sufficient charging has been performed, the needle moves to position 1/1, corresponding to 100% energy available.

In case of partial recharging, the needle stays in its initial state and is not recalibrated.



Once the needle enters the red marking zone, the traction batteries must be recharged very promptly. The vehicle may lose its performance level at all times and stop.

The dropping speed of this indicator depends on your driving style, the use of electric accessories, the number of stops-starts, the road profile, the wear of your batteries, the load transported, tire pressure, low temperature of the batteries, etc. Always drive smoothly to increase the range of your vehicle.

LCD DISPLAY

The control panel features an LCD screen with a total and partial odometer, a drive direction selector position indicator, as well as a clock.

1. Odometers



To reset the tripmaster, press slightly setting button 16 for more than 2 seconds.

2. Reminder of the position of the forward/reverse selector



Indication of the gear engaged (drive D, neutral N, reverse R).

3. Clock



The clock is visible alternately with the trip master. To toggle from one to the other, press setting 16 briefly.

The time is in the 24h format.

To set the time, check it is displayed and press setting button 16 gently for more than 2 seconds. The hours start flashing. Adjust the time by pressing several times on the setting button. Wait for 5 seconds to switch automatically to the minutes setting mode.

CONTROL PANEL (cont'd)



MEANING OF DANGER INDICATORS (red coloured)

The first two indicators are always activated for 5 seconds after activating the ignition key. If they do not light up, call your dealer promptly.



Parking brake and brake fluid level indicator: When lit, it indicates

- your handbrake is not released – in which case there is a risk of power overconsumption and shortened range, as well as early wear of brake pads and linings. Your vehicle does not have a classical gearbox, also even if the drive selector is selected to drive or reverse, the only device which can hold your vehicle when stopped is the parking brake (handbrake). Also, check that it is engaged properly before you leave the vehicle.
- or brake fluid is missing in the braking circuit – risk of brakes degrading. Top up with the fluid recommended.



General Failure Indicator:

A buzzer sounds when this indicator is lit.

It is lit when ignition is turned on, if the speed lever is not in the neutral position, as a safety measure. Return to the neutral position to acknowledge the fault.

If the indicator lights up while driving, several causes are possible:

- The vehicle is at end of range. Vehicle powering off and stopping is imminent. Please stop as soon as possible. Risk of severe damage to the batteries and possible loss of warranty – the vehicle must be recharged immediately
- Traction overheating – wait for the motor to cool down, then turn off the ignition before restarting, at neutral point and without pressing the accelerator pedal.
- The seat switch has been deactivated. For safety purposes the driver's seat is fitted with a seat switch prevent vehicle operation if no driver is in the seat. Raising from the seat for a few seconds causes a fault and powers off the vehicle. Move back to neutral and release the accelerator pedal to acknowledge the fault.
- The accelerator pedal was not released when the speed lever changed position. Move back to neutral and release the accelerator pedal to acknowledge the fault.
- Other fault: call your Mega dealer.



Warning lights indicator: Controls the four direction lights simultaneously and permanently.

Use only in case of danger.

CONTROL PANEL (cont'd)

MEANING OF WARNING INDICATORS (orange colour)



Pad wear indicator: Lit, it indicates that the brake pads are worn – risk of braking degradation. Change the pads immediately.



Windscreen defrosting indicator: When lit, indicates that the windscreen is being defrosted. Defrosting is built into the windscreen. It is timed and stops automatically at the end of its cycle.



Rear fog light indicator: When lit, indicates the rear fog light is activated. Observe the instructions of the traffic code when using this function to avoid any potential disturbance of other users.



Heating seat indicator: When lit, indicates that the heating of one of the two seats or both seats is activated. Check this lamp is lit only when the seat is used by a person. Adjust the seat heating control buttons according to the number and position of the occupants. Refer to the instructions of use in the heating seats chapter.

POWER AVAILABLE INDICATOR



When the needle enters the red zone, the vehicle must be recharged promptly

2. OTHER INDICATORS (outside control panel)



Charge indicator:



Three lighting modes are possible:

- It **flashes regularly and slowly** during charging (about 1 flash per second)
- **At the end of charging, the indicator is lit steady.** If the vehicle stays connected to mains, new charging will start after 24 hours to maintain the level of the batteries.
- If it flashes very fast, it means the charger detected an error. Several possible causes:
 - Timeout exceeded. The duration of one of the charging phases is abnormally high. Disconnect then reconnect your vehicle after a few seconds. If the phenomenon continues, call your dealer as soon as possible as the vehicle's range may be impacted.
 - Over or under voltage on the mains power supply. When the voltage returns to a normal value, the charger restarts automatically, and the indicator flashes slowly again.
 - Charging problem. The charger detected that it was not flowing out current due to an internal fault. Call your dealer as soon as possible as the vehicle's range may be impacted.



Battery water filling warning indicator:



When lit, indicates the traction batteries must be filled with distilled water. This indicator lights up once 7 full charges have been made. Full charge means charging having lasted over 4 hours. At the seventh charge, the indicator lights up and stays on when the vehicle is disconnected from mains. If the vehicle is connected again to mains, the indicator switches off automatically even if the filling operation has not been performed. **Therefore, this operation must be performed once the indicator lights up.**

3. LEFT COMMAND

DIRECTION CHANGE CONTROL



- Press the lever before turning left.
- Lift the lever before turning right. For a direction change, activate the command beyond the hard spot; automatic return and stop with the steering wheel. For your safety, always anticipate your manoeuvres sufficiently by indicating them clearly.

SOUND WARNING (horn)



Press the tip of the control

LIGHTING CONTROL



 **All lights out**
Turn the control forward

 **Position lights**
Turn the control forward Backlighting of the control panel means these lights are on.



Low/high beam

Low / high beam toggle, pull the control towards you.

This vehicle has a reversing light and a rear fog light.

Optical warning

By pulses towards you.



Before leaving the vehicle, check no lights stay on. If they stay on permanently, they discharge the accessories battery even if the main battery is charged or charging. Starting the vehicle is then impossible.

4. RIGHT COMMAND

FRONT WIPER, WASHER

- Press the lever to run the wiper once.
- By raising the lever:
 1. intermittence
 2. slow
 3. fast



Pull the lever towards you to actuate the washer.

WINDSCREEN DEFROSTING COMMAND

To activate it, press the command button located at the end of the control. When using this function, activate the ventilation to remove any trace of residual condensation.



A single press causes the loss of 1 to 3% range.



Activating this function without turning the ignition on may discharge the accessories battery, even if the main battery is charged or charging. Starting the vehicle is then impossible. Prefer the use of this command with ignition on.

5. INTERIOR LIGHTING

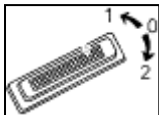

- 0. Off.
- 1. On permanently.
- 2. On when opening the doors.



Before leaving the vehicle, check the dome light is not on. If it stays on permanently, it discharges the accessories battery even if the main battery is charged or charging. Starting the vehicle is then impossible.

6. CENTRAL CONTROL PANEL COMMANDS



WARNING LIGHTS

Controls the four direction lights simultaneously and permanently.
Use only in case of danger.



SLOW SPEED / FAST SPEED

In the « hare » position, the vehicle can reach its maximum speed.
In the « turtle » position, the vehicle can reach only 60% its maximum speed. Using this position improves the range of your vehicle.



PRESENCE WARNING

In the « continuous line » position, the sound emissions allowing to warn the users of your presence are emitted without requiring to hold your finger on the command.

In the « discontinuous line » position, the sound emissions allowing to warn the users of your presence are emitted while requiring to hold your finger on the command.



This command can never be a substitute to the horn which must be used in case of imminent danger.



ENGINE BRAKE ASSISTANCE ADJUSTMENT

The upper position removes braking assistance.

The middle position offers an average setting suited to most situations.

The low position offers a strong setting to be used when transporting heavy loads.



VENTILATION (option)

This command is available when the doors option was chosen and if the additional heating option is not present.

The upper position commands the fan to deliver a low air flow.

The middle position stops the ventilation.

The lower position commands the fan to deliver a high air flow.



FLASH LIGHT or SIGNALING BAR (option)

This command allows to activate the flash light or signaling bar (composed of a signaling triangle and two flash lights)



Before leaving the vehicle, check no lights stay on. If they stay on permanently, they discharge the accessories battery even if the main battery is charged or charging. Starting the vehicle is then impossible.

HEATING SEAT (option)

This command activates the heating system integrated to one or two seats.



Use the seat heating only if a person is sitting on the seat. This person must be able to feel the temperatures and react to them. Persons who by experience have difficulty in feeling temperatures, such as paraplegic, children and elderly persons, should not use the seat heating, as there is a risk of burns. The seat heating must never be started and left unattended. If you or your passenger feel temperatures too high, stop the heating completely.

Ensure you do not transport or place pointy or heavy objects on the seat, as this would be detrimental to the operation of the heating

When the seat heating is on, the seat must never be covered with insulating materials (including covers, jackets, cushions, bags, seat covers,...).

Do not activate the heating if the surface of the seats is humid or wet with any substance. It must not be used with wet or humid clothing. It is not designed to dry clothing or objects.



CIGARETTE LIGHTER, ASHTRAY

ASHTRAY

The ashtray is of the nomad type, it can be removed and moved at will.

CAUTION: When you empty the ashtray, check it contains no incandescent ash likely to cause a fire.

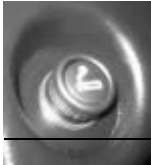

CIGARETTE LIGHTER

Press the cigarette lighter completely. It is ready to use when it returns to its normal position by emitting a click. Pull the cigarette lighter out of its housing to use it.

CAUTION:

- **Hold the cigarette lighter by the button, do not touch the metallic envelope (risk of burns)**
 - **Do not use a non-original cigarette lighter (risk of fire)**
 - **If the cigarette lighter does not pop out after 30 seconds, it may be faulty: pull it out promptly (risk of fire).**
-

7. Additional heating (option)

Operation:



- To light the heating, press the upper left key. You can set the temperature required using the right rotating button. If the heating is in the heating mode, the red LED lights up as a check. After a few minutes, heat is expelled from the vents on the dashboard.
- To activate only the ventilation, press the lower left button. The rotating button then has no function. The blue LED then lights on for checking.
- To stop one mode or the other, press the « 0 » button.

The heating is powerful, also we recommend to ensure not to overheat the cab. To prevent this, turn the rotating button gradually until reaching a comfort temperature. Do not forget to stop the heating when you leave the vehicle.

The heating device can generate odours for a short time upon its initial start-up. This is perfectly normal during the first minutes operation, and does not mean the heating device is subject to malfunction.

 **Do not obstruct the air outlet vents.**

 Before leaving the vehicle, check the system is stopped. If it stays on permanently and the ignition key is not activated, it can discharge the accessories battery promptly (even if the main battery is charged or charging). Starting the vehicle is then impossible.

Filing up diesel fuel (identical to that used in diesel engines):

1. Stop the heating before filing up
2. Remove the tank cap after unlocking it
3. Insert the nozzle and fill the tank
4. When the automatic nozzle blocks, stop filling.
5. Remove the nozzle
6. Fit the cap and lock it.

The vehicle is not fitted with a fuel gauge, also fill up fuel regularly.

 If the heater does not start first fill the tank. Do not attempt to switch on the heater without fuel. After several such attempts, the system may jam and it must be repaired.

Note: The heating device is not homologated for use with bio diesel (FAME). Adding bio diesel (FAME) is possible up to 10 %. Also, used oil mixes are not accepted.

Caution: fuel is a flammable and explosive product. Stay away from flames and do not smoke.
Clean any fuel spill off the body.

8. EMERGENCY STOP



When pressed, it disconnects the traction batteries, isolated them from the motorisation chain, and hence stops the vehicle. Therefore it must be used only in case of emergency (smoke, fire start, burn odours, ...).
Caution ! This emergency stop does not cut the 12V board network.
To release the emergency stop, turn the red button.

9. HOUR METER (option)



The hour meter counts the number of hours the vehicle spent with the ignition key activated.

DRIVING

1. RECOMMENDATION FOR RUNNING-IN

During the break-in period, over the first 500 kilometres, the tires and brake pads do not yet have an optimum adherence and friction force, also the vehicle must be driven while applying the following precautions, to ensure a long lifetime, while driving smoothly and with a good level of performance.

- Do not drive the vehicle at high speed and avoid following other vehicles too close.
- Avoid fast starts. Always observe the speed indicated by the signs.
 - Do not exceed the load limits of the vehicle.
 - The payload announced must also consider the weight of the driver and passenger, equipment options, including various accessories added.
 - The vehicle's range is limited and depends on many parameters which include your driving style. During initial driving, avoid any trips with a length close to the range announced. This period must also allow you to get acquainted with the capacities of the vehicle.

2. STARTING IGNITION

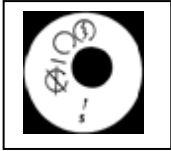

S ANTITHEFT

To unlock the steering, turn the wheel slightly while turning the key without forcing.

ACCESSORIES

IGNITION

Ignition is on. You must hear the « clicking » of the different contacts closing. **Removing the ignition suddenly during this phase can cause a vehicle breakdown. Do not accelerate during this operation.**

STARTER (function non active) **Do not use this position**

3. RUN SELECTOR



N = Neutral point

D = Drive

R = Reverse

To select the gear required, push or pull the lever in the appropriate direction

7. PARKING BRAKE



1. To tighten the brake, pull the lever completely without pressing the button at the tip of the handle.
2. To release, pull the lever slightly while pressing the button, and lower the lever.



CAUTION

- **Using the handbrake in uphill start: release it gradually while accelerating.**
- **Never drive with the handbrake applied. Risk of damage of the rear brakes, premature wear of the traction mechanical and electrical components, energy overconsumption, loss of range.**
- **Do not use the parking brake to slow down the vehicle, except in case of failure of the foot brake.**
- **When parking the vehicle on sloped terrain, always ensure your vehicle is perfectly immobilized before leaving it. Your electric vehicle does not allow you to engage a gear, also the handbrake is the only device allowing to immobilize the vehicle in all circumstances.**
- **Do not park the vehicle in a slope exceeding 15%.**
- **We recommend to place a block against one of the vehicle's wheels when it is parked in a slope for a long period of time.**

5. DRIVING ADVICE

Before starting:

Check:

- the proper adjustment of the rear view mirrors
- the adjustment of your seat, closing of the doors
- the power level of your battery
- no object is likely to roll on the cab floor and prevent the use of the pedals

Buckle and adjust your seatbelt.

Starting:

- Switch the ignition on without pressing the accelerator pedal
- Select the driving direction using the gear lever. If the lever was in the right driving direction, you must however pass again at the neutral point to revalidate the direction (starting safety). « D » or « R » appear on the display of the control panel.
- Release the handbrake. Accelerate slowly.

Driving:

Drive with a single foot to avoid pressing the brake and accelerator pedals concurrently. If pressing simultaneously, priority is given to braking, and traction is interrupted. In uphill starts, use the handbrake.

7.1 Motor brake:

The vehicle has an electric motor brake. At each deceleration or downhill slope, a current is regenerated in the traction battery.



It is indispensable to limit your speed intentionally in downhill slopes using mechanical brakes.

7.2 Range:

The main parameters reducing the range are:

Low battery temperature, many stops-starts, steep roads or paths, “sporty” driving, use of electric equipment (heating, lights, flash light, accessories,...), low tire pressure, battery condition and age, load transported,...

The driver's behaviour has a direct impact on the lifetime of the battery, any aggressive road behaviour has an irreversible impact on ageing of the battery, and hence its range.

New batteries require a « break-in” period before being fully effective.

7.3 End of range:

At end of range, drive smoothly to limit current calls on the traction batteries. Once the needle of the power gage in the red zone, the traction batteries must be recharged instantly to avoid damaging them.

The vehicle's performance can be reduced once the needle enters the red zone.

Stop driving when the general failure indicator becomes active (see paragraph specific to this indicator).



7.4 Influence of temperatures:

When temperatures are close to 0°C, the capacity of the batteries is reduced, and hence the length of your route must be adapted, as well as the use of accessories according to this shorter range.

7.5 Particular cases:

When climbing on the pavement, do it only on lowered sections to avoid misadjusting the front axle, resulting in premature tire wear.

- Call MEGA before installing any load support on the van body. A few instructions must be observed. If these instructions are not observed, MEGA cannot be held liable for any damage or accident resulting from the transport of any object on the roof of the vehicle.

 **The traction battery loses its efficiency throughout its use. However, observing these precautions of use allows to increase its lifetime and extend to the maximum the date of its replacement. Their non-observation results in losing the warranty on the traction batteries.**

Vehicle stop:

- immobilize the vehicle and cut the ignition
- tighten the handbrake

RECHARGING THE VEHICLE

1. Operating mode (observe the other of operations):



Refer to the safety instructions in pages 10 and 11.

Before any connection, check that the mains connector to be used meets standards and is compatible with the recharging current (about 8 to 9A-220V continuous for 10 hours max (according to battery chosen))

The connector, cable, and hands must be clean and dry before connecting the vehicle to 220V mains (or 110V). Always use only the specific cable supplied.

Check that no foreign body is located under the vehicle connector cover.

Cut the ignition key and tighten the handbrake.

Connect the cable to the vehicle. The charging connector is located at the front of the right cab door.



Position tilted before locking



Position vertical after locking

Connect the other end to a standard domestic 16A-230V outlet with an earth connector (according to local regulations- please check).

Charging starts automatically.



Check that the charging indicator on the dashboard flashes

Charging lasts between 8 and 12h approx. Once charging complete (if charging is complete the charge indicator is lit steady), disconnect the cable from mains, then disconnect the cable from the vehicle. Store the cable in the appropriate location in front of the passenger seat).



2. Particular cases:

- When using an electric extension, its total length must be limited to 10 meters max to maintain proper current quality.
- Using a winder is forbidden.

- When recharging several vehicles, we recommend to connect one vehicle per mains outlet only.

- Check that the electricity will not be interrupted during the recharging time



Do not leave a charging cable run on the ground when it is connected to 220V mains without being connected to the vehicle. Risk of electrocution, check the condition of the charging cable regularly (damage, apparent wires).

If your cable is damaged, do not attempt to repair it yourself, but call your approved MEGA dealer.

When the vehicle is charging or if the charging cable is connected to the vehicle, an anti-starting system prevents the motor from running.

3. Recharge when ?

The vehicle can be recharged at any time. Charging can also be interrupted at any time.

It is also strongly advised to charge only when necessary. Indeed, the yield of the traction batteries and charger are clearly better when the traction batteries are nearly empty upon recharging.

Therefore, it is recommended to recharge the vehicle when the power level indicator is around the position 1/4.



However, in all cases, we recommend performing a full recharge minimum once per week, which allows to maintain the set of batteries homogeneous.

Indeed, full charging allows to balance all constitutive cells of your battery, hence ensuring your battery will give the maximum of its capacity.

Note: Full charging = the charge indicator of the dashboard is lit steady when the charge cable is disconnected.



The battery cannot be recharged if the temperature of its electrolyte is below - 10°C also the vehicle must be recharged inside temperate buildings (which also extends its range).

By negative temperatures we recommend charging the vehicle upon end of driving. This allows to take advantage from the existing operating heat of the battery to initiate charging. It is also recommended to maintain the batteries charged at maximum of their capacity. Also, ensure the battery water filling system is not frozen.

4. Recharge where ?



RISKS OF EXPLOSION



RISK OF OUTGASSING

Refer to pages 10 and 11 of this manual.

Hydrogen is outgassed while charging. This process occurs rather at end of charging. Caution ! Hydrogen is odourless and undetectable.

As a concentration of 4% hydrogen in the air is an explosive mix, for obvious safety reasons, always ventilate the rooms where batteries are recharged, according to the rules enforced in the country concerned. It is also recommended to avoid smoking and avoid using sources likely to generate flames.

When the charge indicator flashes fast (charging fault), ensure these rules are observed and call your Mega approved dealer promptly, as risks related with hydrogen outgassing are then at their maximum.

5. Topping up distilled water in the batteries

Topping up distilled water in the traction batteries must be performed every 7 full charges and/or at least once per week, and this only after full electric recharge.

Frequent checking during first uses allows to establish the frequency for topping up with water, if it is to be increased.

- 1- Wear gloves and glasses, and check the lack of sources of flames or incandescent heat in the vicinity.
- 2- Ensure the distilled water tank is full.
- 3- Connect the female connector onto the male connector after removing its red cleanliness seal (the male connector is onboard and located on the left side of the vehicle (see photo below)).
- 4- Position the tank on the cabin top and remove its cover.
- 5- Open the tap, the water falls by gravity in batteries.
- 6- Once the water fan doesn't move anymore disconnect the connectors and replace the cleanliness seal.



Male connector of the vehicle filling system



Filter

Water fan

A water level indicator next to the connector allows to check that the water level was topped up properly. In this case, it lights up steady in green. Otherwise, it flashes red (then check that the pump is hard, and if not, have your battery filling system checked by your dealer).

Use distilled water only. Non distilled water can contain particles likely to impact the performance and lifetime of your batteries, and cancel your warranty.

6. Auxiliary equipment

The auxiliary equipments of the vehicle sample all the energy on the traction battery, directly, or via the accessories battery and its converter. Using the headlights, the wiper, radio, or any other electric equipment impacts the vehicle's range. Adding equipment not planned by the Manufacturer is strictly forbidden and requires approval by the Manufacturer. Indeed, an electric budget must be established to decide the capacity of the system to provide the additional energy required and its impact on the vehicle's performance.

VEHICLE STORAGE



The instructions given below aim at preserving the performance of your battery over time, and must be followed. Their non-observation results in losing the warranty on the traction batteries.

1. If the planned immobilisation exceeds one month:

Disconnect the vehicle from mains once you are sure charging is complete.
Every month, perform full charging.

2. If the planned immobilisation is less than one month:

Leave the vehicle connected to mains once ensured charging is complete. The charger restarts the charging regularly to maintain the batteries at full charge.



Recycling batteries: entrust your used batteries to a recycling professional. Do not store them in non suitable and non isolated locations, and do not abandon them in the wild.

SAFETY RELATED WITH THE BATTERY

Lead/acid accumulator batteries do not burn, or burn with difficulty. Do not use water in fires where melting metal is present. Put off fires with an appropriate agent to surround combustible materials. Cool the outside of the battery if it is exposed to fire to avoid breakage. Acid mist and vapours generated by heat or the fire are corrosive. Use an autonomous respiratory apparatus and full protection equipment used in positive pressure mode.

1. **NEVER** open the battery
2. **NEVER** modify the electric circuits without manufacturer authorization
3. **ALWAYS** perform the inspection visits recommended
4. **NEVER** access the zone indicated by a yellow



triangle with a black lightning bolt.

5. **ALWAYS** observe all instructions on the dashboard
6. **NEVER** stay in the vehicle in case of smoke.

Ignoring these safety instructions may cause severe injury.

CLEANING THE VEHICLE

CAUTION

Chemicals may be dangerous. Some are toxic, others ignite near flames or when used on a part of the vehicle which is still hot. In a poorly ventilated area, inhaling the vapours of certain substances may cause a malaise or an intoxication. Always read the instructions on the container of any chemical before use. When using the product indoors, open the doors and windows.

Avoid using the following products for vehicle maintenance:

- Gasoline
- Benzene
- Naphta
- Acetone
- Carbon tetrachloride
- Paint thinner
- Turpentine
- Varnish thinner
- Nail varnish thinner
- Etc....

These products are dangerous and may damage le vehicle.

CLEANING THE CAB

Remove dust from the cab using a vacuum cleaner.

Wash the plastic elements with water and soap.

For seats and mats, use products sold in stores for this purpose.

Do not spray water in the cab, particularly when washing a vehicle without doors.



A vehicle without doors must not be stored outside. It must be protected from the weather.

CLEANING THE BODY

Wash the vehicle as soon as possible when exposed to dirt likely to enhance corrosion and more particularly:

- Sea water, chemicals used to defreeze the roads in winter.
- Soot and dust, iron powder from factory smoke, chemicals (acid or basic substances, tar, etc.).
- Bird droppings, insect debris, tree resin, etc.
- Mud, gravel,... built up in retention zones



The presence of humidity or de-icing salt in the braking system may extend the braking distance, also avoid any sudden braking after washing the vehicle, and dry the pads by cautious braking.

WASHING

- Use only water and liquid soap.
- Avoid refilling under the sun or when it is freezing.
- Do not wash the vehicle in automatic carwash stations.
- **Never use a high pressure jet**
- Never spray water on the electrical components or batteries. This may cause irreversible damage.

CLEANING THE WINDOWS

Clean the windows with water and soap or with a special window cleaner while avoiding contact of the latter with the body.

TIRES

PUNCTURE

This vehicle is not fitted with a spare wheel, but a temporary tire repair kit.

After breakdown repair, go to the closest garage to have the tire repaired.

REPAIRING A WHEEL IN CASE OF PUNCTURE

- Place the vehicle on flat ground.
- Apply the parking brake (if required shim the vehicle).
- Remove the object having punctured the tire and position the valve wheel at the top
- Shake and connect the tube to the valve
- Empty the spray while maintaining it head up
- Drive immediately for a few kilometres to distribute the product.
- Check pressure after 12 hours.



DO NOT EXPOSE THE CONTAINER TO A TEMPERATURE ABOVE 50°C (e.g. behind the windshield)

CONDITION OF THE WHEELS

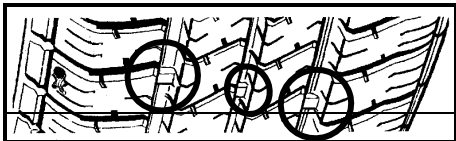

The condition of your tires must be inspected regularly. Several « wear indicators » are led at the bottom of the original assembly tire treads, perpendicular to the driving direction. Change the tires when the wear indicators are reached.

TIRE PRESSURE AND INFLATING (BAR)

TIRES		FRONT	REAR
155 / 80 R 13 79T	Empty	2.8	2.8
155 / 80 R 13 79T	Loaded	2.8	2.8

The tire pressure has a direct impact on your safety and range of your vehicle.

Caution: the use of snow tires (M+S or M/S) may shorten the range of your vehicle

OPENING THE HOOD

The opening rod is located under the dashboard, next to the left-hand foot rest.

The hood holding rod is located on the internal face of the hood. A small housing is located on the level of the light support



TOOL CHEST (long chassis version)

Do not store more than 40 kg equipment per chest.

ACCESSORIES BATTERY

The accessories battery is located under the hood, which is opened using the handle under the steering wheel, on the left.



(+) terminal

(-) terminal



Intervene on this equipment yourself only if you are acquainted with the operations required, and using appropriate tools. If not, entrust the intervention to your approved dealer.

- Access: open the hood and fasten its prop in the appropriate housing.
- If you wish to start from another battery. Check the spare battery is a 12V battery. Connect one end of the red cable to the (+) terminal of your faulty battery, then the other end to the (+) terminal of the spare battery. Connect one of the black cable or

green cable to the (-) terminal of the spare battery, then the other end to a metallic part of the chassis of your vehicle (ground). Start the repair vehicle and wait for a few minutes. Turn the ignition on and check the panel is lit. Disconnect the cables in the reverse sequence. Close the cover.

- To recharge your accessories battery using a charger, remove it from the vehicle and have it charged in a ventilated room while applying all safety precautions required.

CHANGING THE FUSES

CAUTION: When you change a fuse, always use the same amperage (risk of fire).

A fuse box is located under the hood. The yellow fuse extraction clamp is located on the box cover.

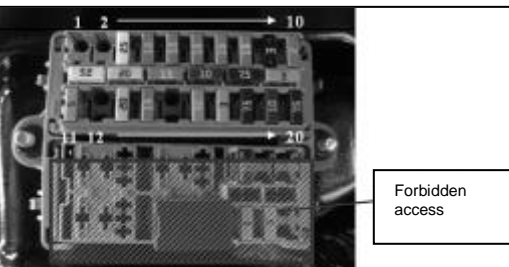

1	(+)PER	option
2	(+)PER	option
3	25 A (+)PER	Front defrosting
4	15 A (+)PER	Warning lights
5	15 A (+)PER	Car radio, 12V accessory socket, horn
6	15 A (+)PER	High beam
7	15 A (+)PER	Low beam
8	15 A (+)PER	Position lights, fog lights
9	3 A (+)PER	On-board instruments
10	2 A (+)PER	Dome light
11	5 A (+)ACC	Car radio
12	Not used	
13	20A (+)APC	Wiper
14	15 A (+)APC	Fan
15	Not used	
16	30 A (+)APC	Heating seats option
17	3 A (+)APC	Reverse buzzer, presence warning, defrosting time out
18	7.5 A (+)APC	Stop lights
19	10 A (+)APC	Indicators
20	7.5 A (+)APC	Flash light or signaling bar option (triangle + lights)

CHANGING BULBS

CHANGING THE LAMP OF THE FRONT POSITION LIGHT

– To gain access, open the hood, unscrew the three black crown fastening screws, remove the seal, and pull the lamp holder socket. Change the bulb.

CHANGING THE LOW BEAM - HIGH BEAM LIGHT BULB

– Proceed as above and unclip the lamp holder socket located behind the insert. Change the bulb.

CHANGING THE LAMP OF THE FRONT INDICATOR LIGHT

– To gain access, unscrew the two fastening screws of the transparent part of the light. Change the bulb.

CHANGING THE REAR LIGHT BULB

– Using a screwdriver, unscrew the two fastening screws of the transparent part of the light. Change any bulbs required.

CHANGING THE INTERIOR LIGHTING LAMP

Unclip the interior lighting from the dome light to change the lamp.

LEVELS

OIL LEVEL OF THE REDUCER AXLE

- Loosen the level screw (2) and pull it out. For a proper oil level, the oil must be flush.
- To top up: Loosen the filling cap (1) and pull it out.
- Always use the quantity of oil specified in page 20 as well as its viscosity. Excess oil causes leaks.

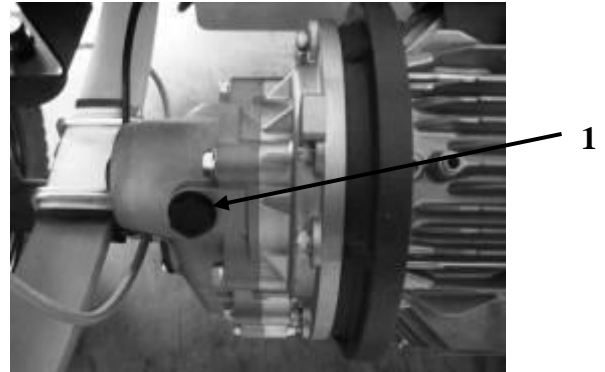
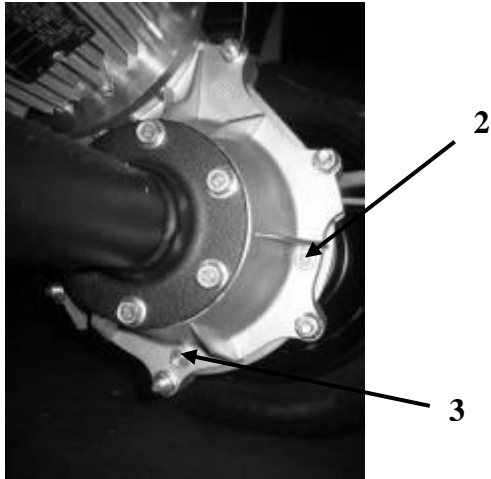

- (1) Filling cap
- (2) Level screw
- (3) Oil change plug

WASHER FLUID LEVEL



Open the hood to access the washer fluid cap.
Top up with alcohol-free washer fluid.



The use of alcohol-based products is forbidden as they would damage the front bumper

BRAKE FLUID LEVEL

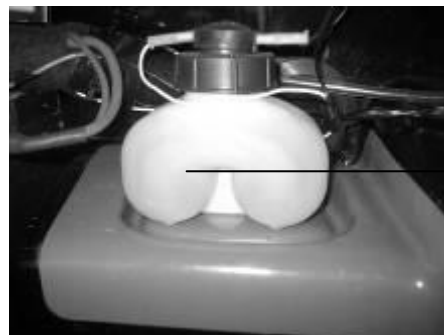

Mini

- Top up if necessary.



We recommend changing the brake fluid every year.



In case of spill of brake fluid when filling, wipe the excess fluid while ensuring it does not drip on the grey plastic support holding the tank (risks of cracks in contaminated surrounding materials)

BREAKDOWN REPAIR TOWING

If you are immobilized following an accident or a breakdown, do not have your vehicle towed. (Major risk of damage of mechanical elements).

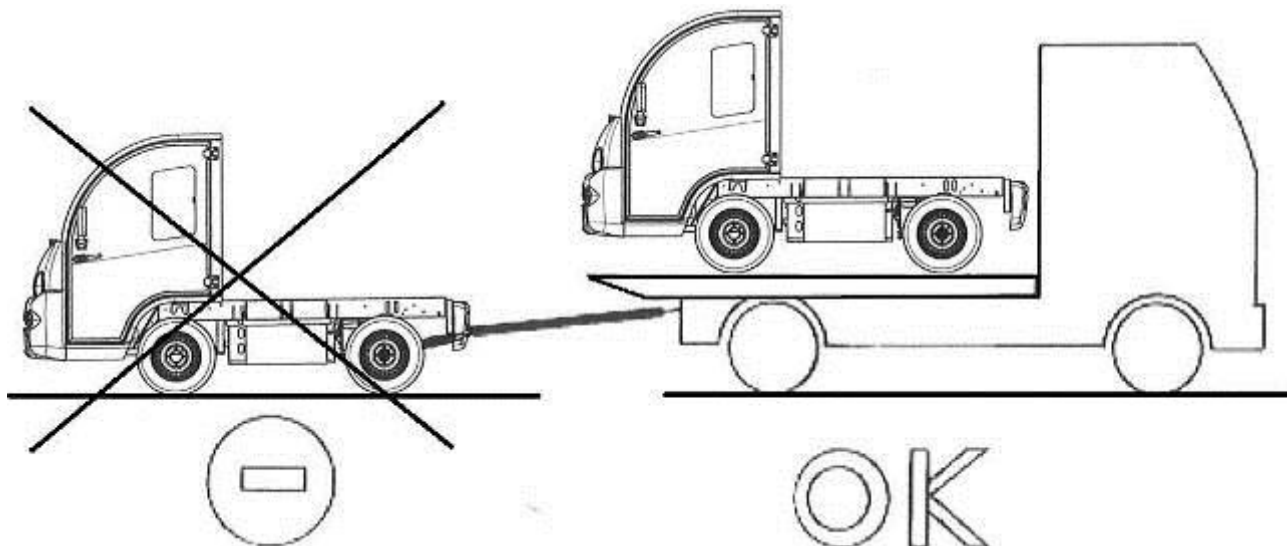

Your vehicle must be hoisted onto a platform, by a professional duly authorized and equipped for this operation. There is a towing located on the front bumper, which allows to raise the vehicle onto the platform safely (ring resistance: 820 daN).

LOADING:

GENERAL RULES:

- Loading material or equipment must be performed on flat, horizontal and stable terrain.
- Do not load with public work vehicles.
- The load must be centred and distributed evenly.
- Solid objects (pallet, crate, furniture, etc.) must be properly stowed and blocked.
- During loading, no personnel must be located in the cab.
- A safety perimeter must be observed by any person not authorized during loading.
- Do not drive with the stakes or curtains open and unlocked.
- Hydraulic bed: do not drive with the bed raised.
- Control of the hydraulic beds is performed on flat, horizontal, stable terrain, and vehicle stopped. A safety perimeter must be observed by all persons during command. Never pass under the bed nor place your hand or objects under the bed

PARTICULAR RULES:

- Refer to the user manual specific to the equipment in your vehicle (hydraulic bed, van, etc.).

TROUBLESHOOTING

This information is intended to carry out basic checks. It is destined exclusive to authorized Mega Pro dealers, which are the only people authorized to repair this vehicle.

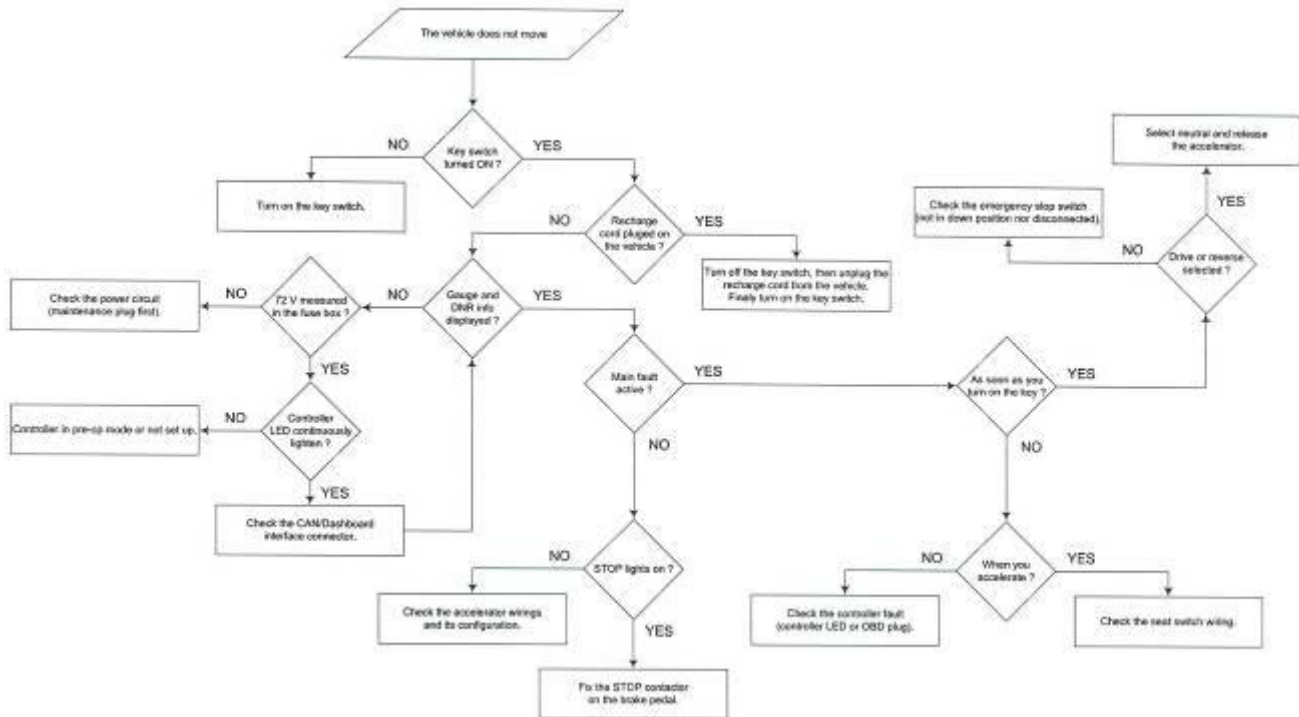

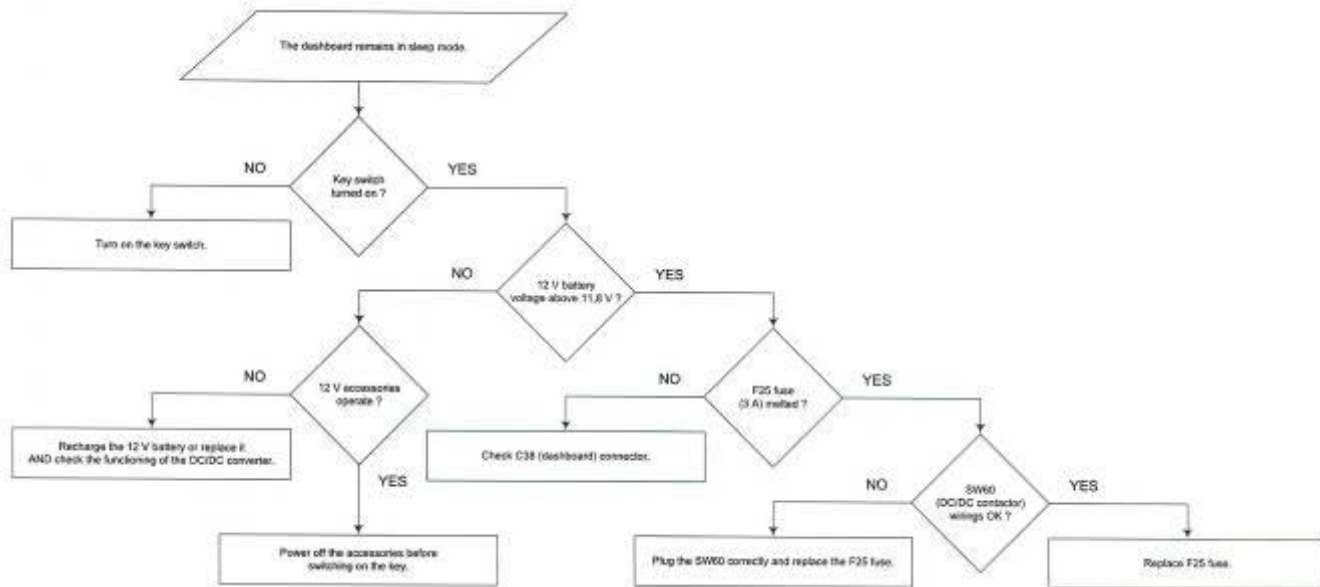

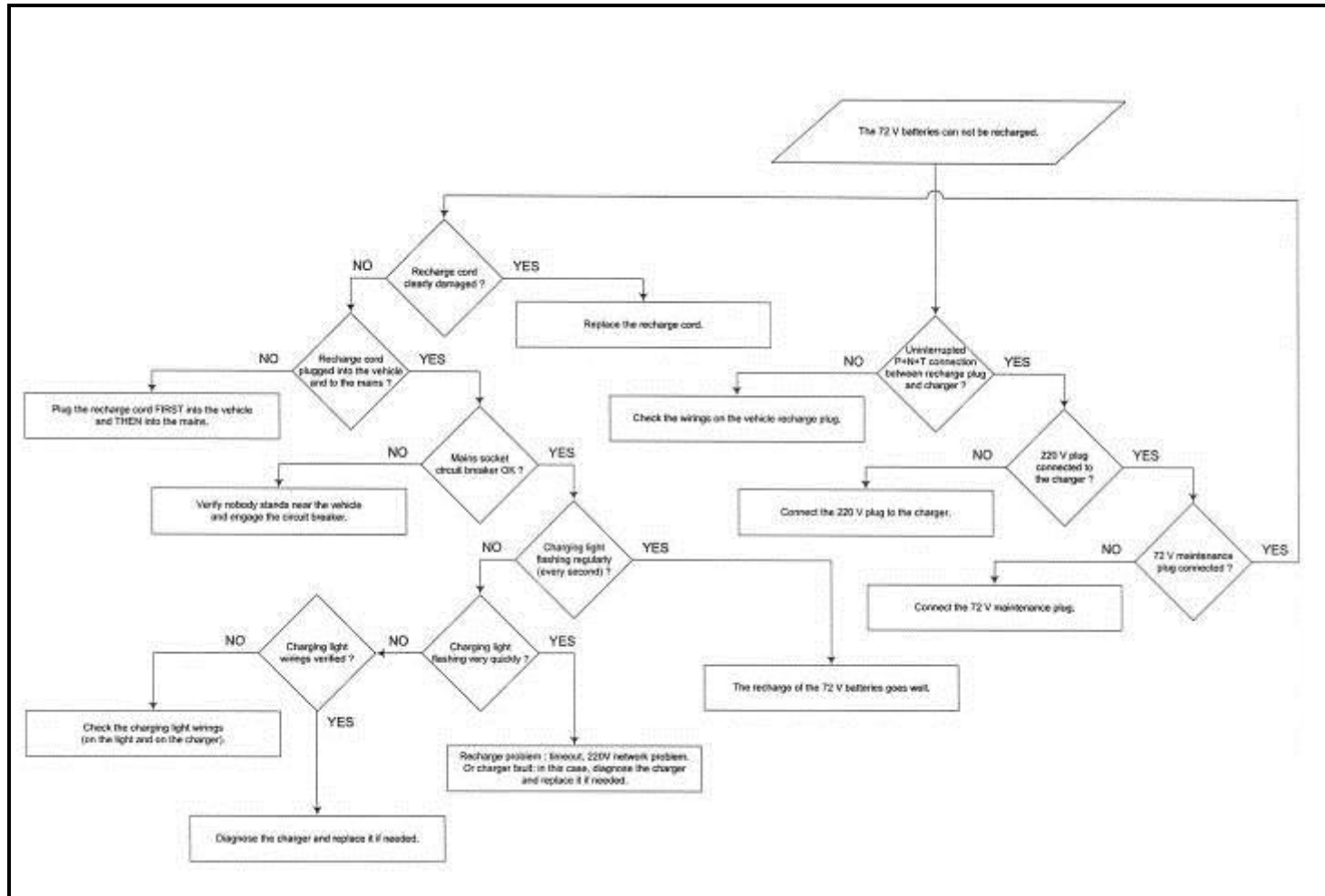

In case of immobilisation of the vehicle
outside the sector of your dealer,
Please call **33 (0)4 79 61 42 45**,
while specifying the area the vehicle is located in.
We will tell you where the closest agent is.

OMP201-EN



MEGA

HEADQUARTERS AND FACTORY
56 route de Pugny – B.P. 112
F – 73101 – AIX LES BAINS CEDEX
Tel. +33 (0)4 79 61 42 45
Fax +33 (0)4 79 35 06 11