



# CS20 Series

21 - 24.5 HP





# CS20 SERIES

Small in stature, massive in power.

Ergonomically designed to keep you working in comfort until the dirty work is done. Powerful, but compact for your jobs of all sizes.

KIOTI Diesel Engine

Tilt Steering Wheel (HST model)

Standard Stationary PTO

Ergonomic Operator System

Hydraulic PTO

All Steel Platform





# BUILT FOR COMFORT, USER FRIENDLY, HARD ON WORK

## Distinctive Hood Design

The streamlined hood design improves the visibility for the operator. A vertical opening hood allows for easy access to the air filter, fluid service and inspection locations, fuse box and electrical components.



## Illuminated Dashboard

The dashboard illuminates when the engine is started. The digital gauge package includes tachometer, fuel and temperature gauges along with a low fuel warning lamp.

## Power Steering with Tilt Wheel (HST model)

Power steering makes it easy to take tight, repetitive turns. The standard tilt steering wheel ensures all operators can reach and turn the wheel comfortably.



## Twin HST Pedals

Twin HST pedals allows easy and quick forward and reverse with smooth engagement, acceleration and deceleration. Dual pedals provide easier use which reduces operator fatigue during long hours of work and when doing repetitive tasks.

- Stationary PTO
- Air-Cylinder Fordable ROPS
- Useful cup holder
- Twin brake pedal (Mid ROPS model)



## Redesigned Operator Station and All Steel Platform

With an all-steel platform and rubber deck mat, the redesigned CS Series operator station allows the operator to easily reach all controls, making it both comfortable and user-friendly.



## Standard Tool Box

New CS20 series is equipped with spacious tool box.



## Hydraulic PTO

Hydraulic PTO clutch offers great durability and ease of use. Simply rotate the knob to engage or disengage the PTO.



## Cruise Control (HST)

Cruise control (Optional) allow operators to set and maintain desired speed.



## Mid PTO

The mid PTO (2,200 rpm) provides the ability to attach and operate implements such as the KIOTI mid-mount mower.



## Joystick Valve (HST)

The CS 20 joystick valve gives operators convenient, comfortable and precise control over the loader to lift, lower and carry loads anywhere you desire regardless of experience or skill level.



## KIOTI Diesel Engine

Fully designed and created by KIOTI, the 21 hp (15.6 kW) - 24.5 hp (18.3 kW) premium, water-cooled diesel engines have large power output, yet low fuel consumption.



**EASY TO OPERATE.  
EASY TO MAINTAIN.  
HARD TO BEAT. CS20 SERIES**

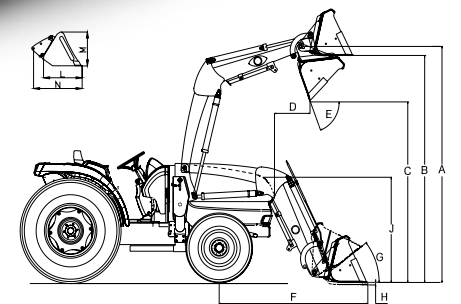

**Front End Loader**

MODEL	KL115A	KL115C
Tractor model	CS2220U-EU CS2520U-EU	CS2520H-EU
A Maximum Lift Height	1,842mm	
B Clearance with Attachment Level	1,682mm	
C Clearance with Attachment Dumped	1,386mm	
D Reach at Maximum Lift Height(45°)	572mm	
E Maximum Dump Angle	73.8°	
F Reach with Attachment on Ground	1,331mm	
G Attachment Rollback Angle	35°	
H Digging Depth Below Grade	64mm	
J Overall Height in Carry Position	1,157mm	
L Depth of Attachment (to back of inner shell)	374mm	
M Height of Attachment	452mm	
N Depth of Attachment (to pivot pin)	485mm	
Lift Capacity to Full Height at Pivot Pins	527kgf	
Breakout Force at Pivot Pins	875kgf	
Lift Cylinder	ø45mm×550mm	
Bucket Cylinder	ø45mm×570mm	
Bucket Width	1,220mm	
Bucket Weight	45kg	
Approx. Weight (without Bucket)	164kg	
Bucket Capacity	0.17m³(0.12m³)	

**Mid-Mount Mower**

MODEL	SM2410	SM2420
Discharge Type	Side Discharge Side	
Cutting Width	60 in. (1,524 mm)	54 in. (1,364 mm)
Cutting Height	1-4 in. (25.4-101.6 mm)	.8-3.8 in. (20.3-96.5 mm)
Transport Height	6 in. (152.4 mm)	
Gear Type	Spiral Bevel	
Number of Blades	3	
Blade Spindle Speed	2,888 rpm	
Blade Tip Velocity	78.2 m/s	71.1 m/s
Blade Length	20.4 in. (517 mm)	18.5 in. (470 mm)
Deck Thickness	0.13 in. (3.2 mm)	
Total Width	73.4 in. (1,865 mm)	69.3 in. (1,760 mm)
Total Length	37.9 in. (962 mm)	35.7 in. (908 mm)
Total Height	10.8 in. (273 mm)	10.5 in. (267 mm)
Drive Type	U-Joint and V-Belt	
Lifting Type	3 Point Hitch Links	
Loader Compatibility	Yes	

\* Specifications and design are subject to change without notice.

\* Specifications and design are subject to change without notice.

**KIOTI SUB-COMPACT  
TRACTOR**



# SPECIFICATIONS



ISO 9001  
NO.954596



ISO 14001  
NO.771475



OHSAS 18001  
NO:K033008

MODEL	CS2520H		CS2220(N)U	CS2520(N)U
	HST		Manual	
<b>ENGINE</b>				
Manufacturer	Daedong		Daedong	Daedong
Model	3C100LWH-E2		3C100LWM-E1	3C100LWM-E1
Engine Gross Power	HP	24.5	21	24.5
Rated Revolution	rpm	3200	3200	3200
No. of cylinders		3	3	3
Displacement	cc	1007	1007	1007
<b>CAPACITY</b>				
Fuel Tank	ℓ	25.5	23.5	23.5
<b>PTO</b>				
		Independent	Transmission	Transmission
Rear PTO	rpm	540	540	540
Mid PTO	rpm	2200	2200(N/A for Mid ROPS model)	2200(N/A for Mid ROPS model)
<b>HYDRAULIC</b>				
3 Point Lift Control Type		Inching	Inching	Inching
Implement pump	ℓ/min	18.7	18.7	18.7
Power steering pump	ℓ/min	7.7	7	7
Total Hydraulic Flow	ℓ/min	26.4	25.7	25.7
3-Point hitch type		Category I	Category I	Category I
Lower Link type		BALL	BALL	BALL
Lift capacity at lift point	kg.f	715	715	715
Lift capacity at 24 in.behind lift point	kg.f	318	318	318
Drawbar type		Bar	Bar	Bar
No. of Remote valves (Rear)		STD.	Option(2ports)	STD.
<b>DRIVE TRAIN</b>				
Transmission		HST	MECH	MECH
Main gear shift x range gear shift		Infinite, 2 range	3F(1R)×2 range	3F(1R)×2 range
No. of speeds		-	6F×2R	6F×2R
Steering		Power Steering	Power Steering	Power Steering
Brake type		Wet disc type	Wet disc type	Wet disc type
Mechanical differential lock		Rear Standard	Rear Standard	Rear Standard
Front wheel drive system		Mechanical	Mechanical	Mechanical
<b>TRAVELING SPEEDS</b>				
Forward	km/h	0 ~ 15.4	1.13 ~ 19.32	1.13 ~ 19.32
Reverse	km/h	0 ~ 10.6	1.39 ~ 7.50	1.39 ~ 7.50
<b>DIMENSIONS</b>				
Overall length (incl. 3-pt hitch)	mm	2523	2623	2623
Overall width (minimum tread)	mm	1168(IND.)	1070(AG)	1070(AG)
Overall height (with ROPS)	mm	2280	2123(AG)	2123(AG)
Overall height (with Field option Cabin w/o beacon)	mm	1990	-	-
Tread width Front 4wd	mm	923(IND.)	911(AG)	911(AG)
Tread width Rear	mm	864(IND.)	869(AG)	869(AG)
Wheelbase	mm	1400	1500	1500
Min. Ground Clearance	mm	162	190(AG)	190(AG)
Turning Radius (w/ brake)	mm	2540	2526(AG)	2526(AG)
Weight with ROPS	kg.f	705	710	710
Weight with Field option Cabin	kg.f	875	-	-
<b>TIRE SIZE</b>				
AG. Tire	Front	-	5-12	5-12
	Rear	-	8-16	8-16
Turf Tire	Front	18×8.5-10 R3	18×8.5-10 R3	18×8.5-10 R3
	Rear	26×12.00-12 R3	26×12.00-12 R3	26×12.00-12 R3
Industrial Tire	Front	18×8.5-10 R4	18×8.5-10 R4	18×8.5-10 R4
	Rear	26×12.00-12 R4	26×12.00-12 R4	26×12.00-12 R4

\* NOTE : Specifications and design are subject to change without notice.

## Standard Equipment

- Rear PTO
- Mid PTO (not applicable for Mid ROPS model)
- Rear View Mirror
- Parking Brake
- Horn
- 7 Pin Socket
- Signal Lamp
- Power Socket
- Front Hitch
- PTO Cover
- Cup Holder
- Remote Hydraulic Valve (for 25HP)
- Tilt Steering (for HST model)
- Twin HST Pedal (for HST model)
- Twin Brake Pedal (for Mid ROPS model)

## Optional Equipment

- Front Weights
- Rear Working Lights
- HST Cruise (for HST model)
- Sun Canopy
- Hydraulic Filter Guard
- Joystick Valve (for HST model)
- 3rd Function Joystick (for HST model)
- Remote Hydraulic Valve (for 22HP)
- Field Option Cabin (for HST model)

## Available KIOTI Attachment

- Front End Loader
- Mid-Mount Mower



**Daedong Kioti Europe B.V.**  
Koerilenstraat 2-6, 3199 LR, Maasvlakte  
Rotterdam The Netherlands  
Tel +31(0)181-35 30 24  
Website [www.kioti.eu](http://www.kioti.eu)

