

# KOHLER® COMMAND PRO®

7.75 to 11 Ft-Lbs Engines

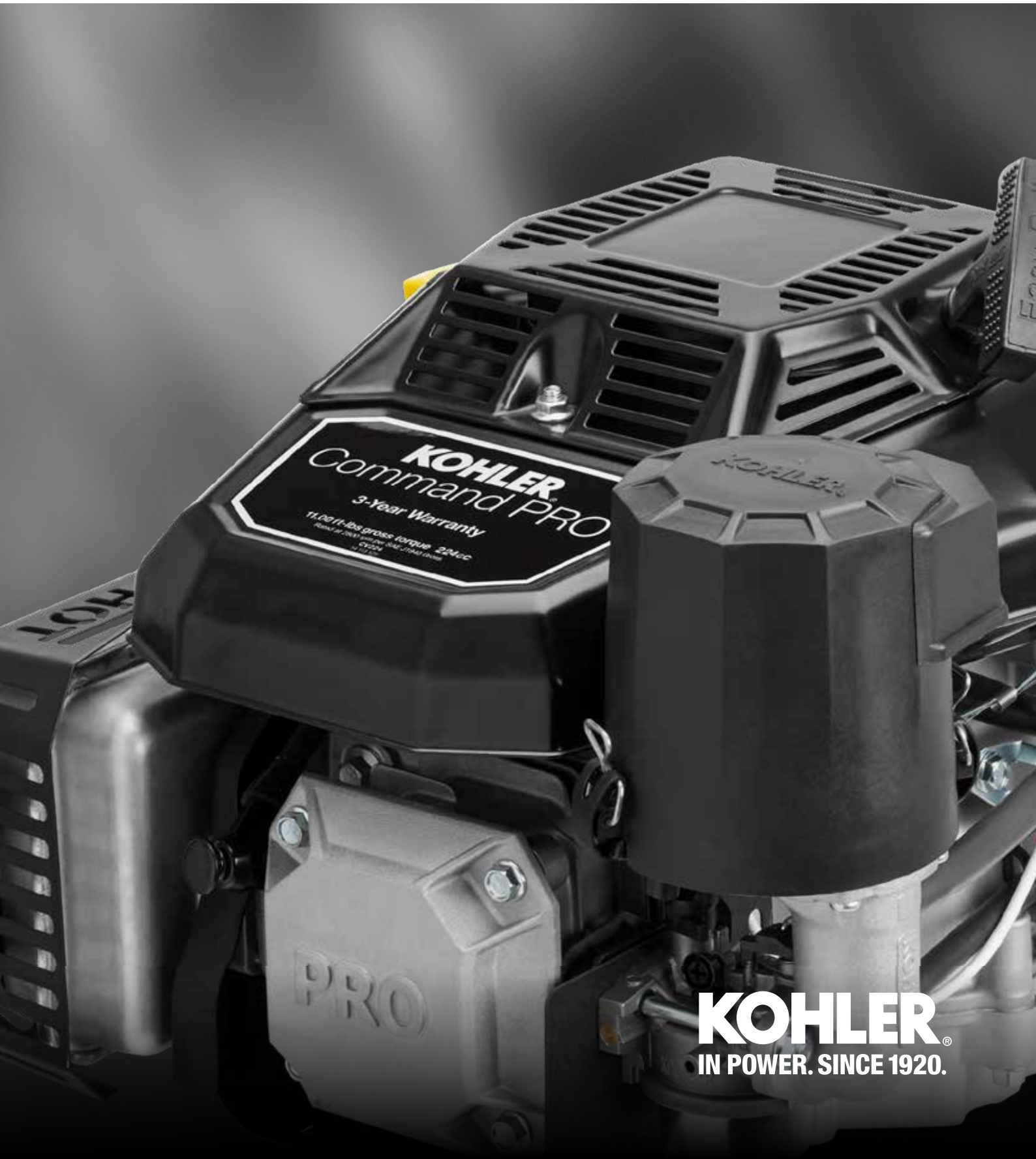

**KOHLER®**  
**Command PRO**  
3-Year Warranty  
11.00 Ft-Lbs gross torque 294cc  
Model # 20617 (with 5.0L-1000L 10000)  
C7524  
10.1.10

**KOHLER®**  
IN POWER. SINCE 1920.



**IMAGINE THE ULTIMATE COMMERCIAL ENGINE.  
NOW OPEN YOUR EYES.**

When your crew's out for a job, they need power they can count on—no matter the conditions. Enter KOHLER® Command PRO® 173 to 224-cc walk-behind engines. The ultimate in durability with best-in-class power\* to cover more ground quicker than ever before.



## **KOHLER COMMAND PRO ENGINES CV224, CV200, CV173**

### **BUILT TO LAST**

- Full-pressure lubrication with Clean-Change™ oil filter for easy, no-mess oil changes
- Fully sealed, four-stage cyclonic Quad-Clean™ air filter protects engine from dirt and debris
- Die-cast valve covers with reusable rubber gasket
- Steel oil pump gear
- Stamped-steel engine cover and recoil assembly

### **POWER. PRODUCTIVITY. PROFIT.**

- Best-in-class power\*
- Industry-leading torque with engine models at 11.0, 9.50 or 7.75 ft-lb—to make short work of tall grass
- KOHLER® Consistent-Cut™ technology for higher engine speed in tough grass for a cleaner turf cut

### **WE'VE GOT YOUR BACK**

- Three-year limited commercial warranty

### **ALL OF THE PROTECTION, NONE OF THE MESS**

- Clean-Change™ Technology – allows for easy oil changes without the mess



# KOHLER® COMMAND PRO®

## 7.75 to 11 Ft-Lbs Vertical-Shaft Engines

### HEAVY-DUTY AIR CLEANER

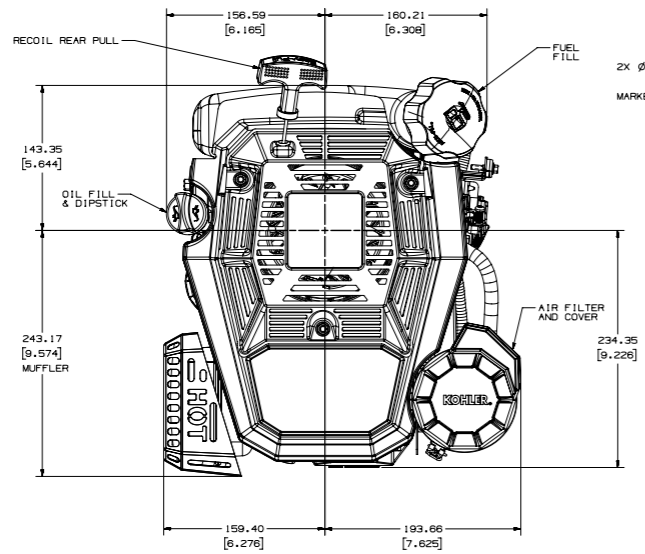

Top view

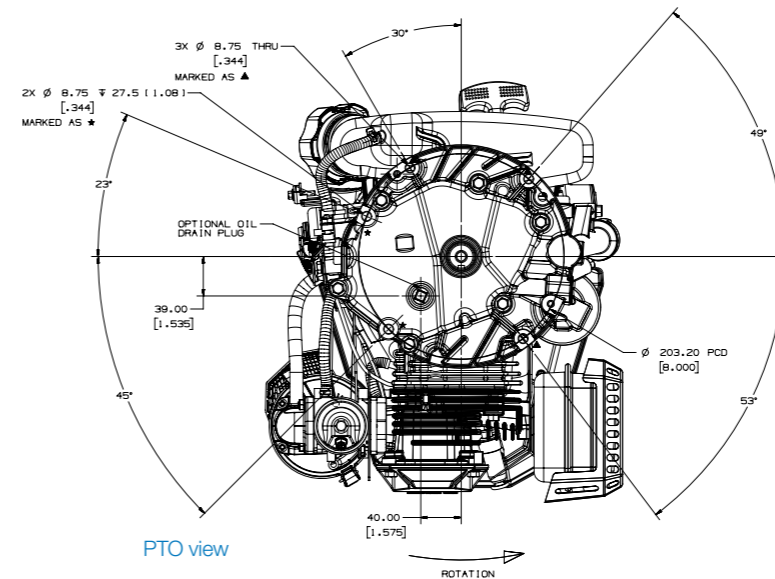

PTO view

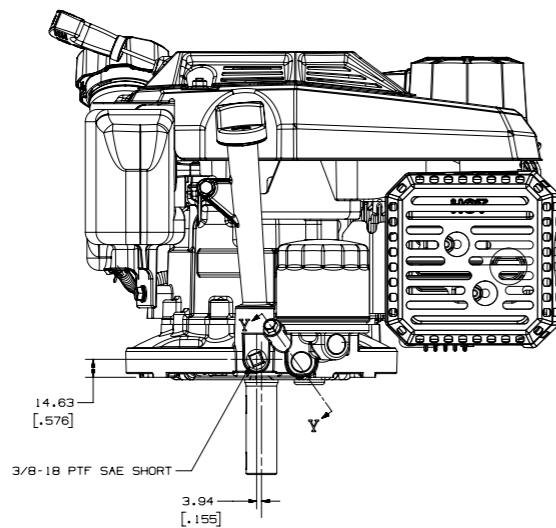

Muffler view

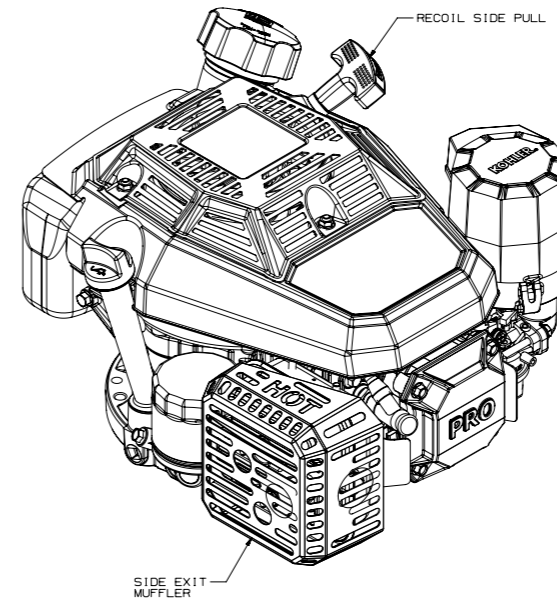

Isometric view

### MAXIMUM TORQUE

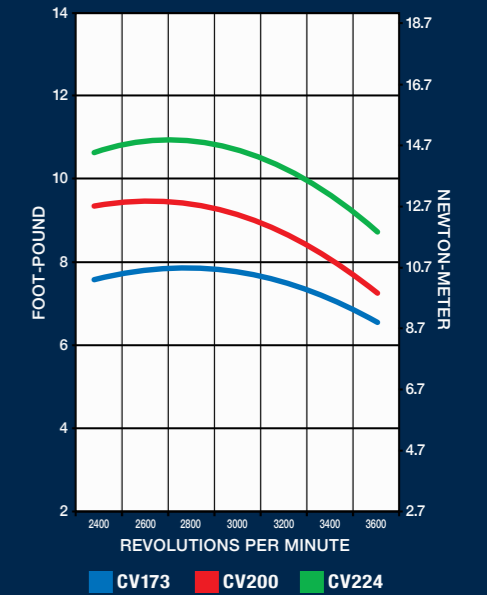

# KOHLER® COMMAND PRO®



CV224



## STANDARD FEATURES

Cast-iron cylinder bore	Stamped-steel engine cover	Engine-mounted controls	In-line fuel filter
Die-cast valve cover with reusable rubber gasket	Stamped-steel recoil assembly	Quad-Clean™ four stage, cyclonic air filter	Front discharge muffler with guard
Full-pressure lubrication with spin-on oil filter	Easy-Pull™ starting	Die-cast intake manifold	EPA-compliant
Steel oil pump	1.4l Accu-Fill™ (easy-fill) fuel tank	Rear pull zone start	CARB-compliant
Clean-Change™ oil pan	High-mount oil dipstick	Zone start crankshaft-25 mm x 79.175 mm x 4.75 mm x 7/16-20	EU Stage V-compliant
			Three-year commercial warranty

## POPULAR FACTORY OPTIONS

BBC-compatible crankshaft - 7/8" x 61.415 mm x 4.75 mm keyway, threaded OD	Side pull (3 o'clock) recoil assembly	Side discharge muffler	Variable speed 1800-3500 rpm
--	---------------------------------------	------------------------	------------------------------

ENGINE TYPE		Four-cycle, gasoline, OHV, cast-iron cylinder liners, aluminum block		
MODEL		CV173	CV200	CV224
GROSS POWER @ 2600 RPM	ft-lb (Nm)	7.75 (10.5)	9.50 (12.9)	11.0 (14.9)
DISPLACEMENT	cu in (cc)	10.6 (173)	12.2 (200)	13.7 (224)
BORE	in (mm)	2.8 (70)	2.9 (73)	2.9 (73)
STROKE	in (mm)	1.8 (45)	1.9 (48)	2.1 (53.5)
COMPRESSION RATIO		8.0:1	8.9:1	9.2:1
DRY WEIGHT	lb (kg)	36.2 (16.4)	37.0 (16.8)	
OIL CAPACITY	U.S. qt (L)	0.63 (0.6)		
LUBRICATION		Dual-Pressure lubrication with full-flow filter and splash		
DIMENSIONS* L x W x H	in (mm)	15.7 x 13.9 x 11.1 (399 x 353 x 281)		

\*Length is front of valve cover to back of blower housing. Width is side to side. Height is mounting surface to grass screen.



For more information, contact your KOHLER source of supply.  
Kohler Co. reserves the right to make modifications without prior notice.

**KOHLER**<sup>®</sup>  
IN POWER. SINCE 1920.

**KOHLERPOWER.IT**

Printed in Italy    ED0035585810    Rev.00 02/20 Eng    KOHLER CO.