





Technical

assistance manual

Series 30

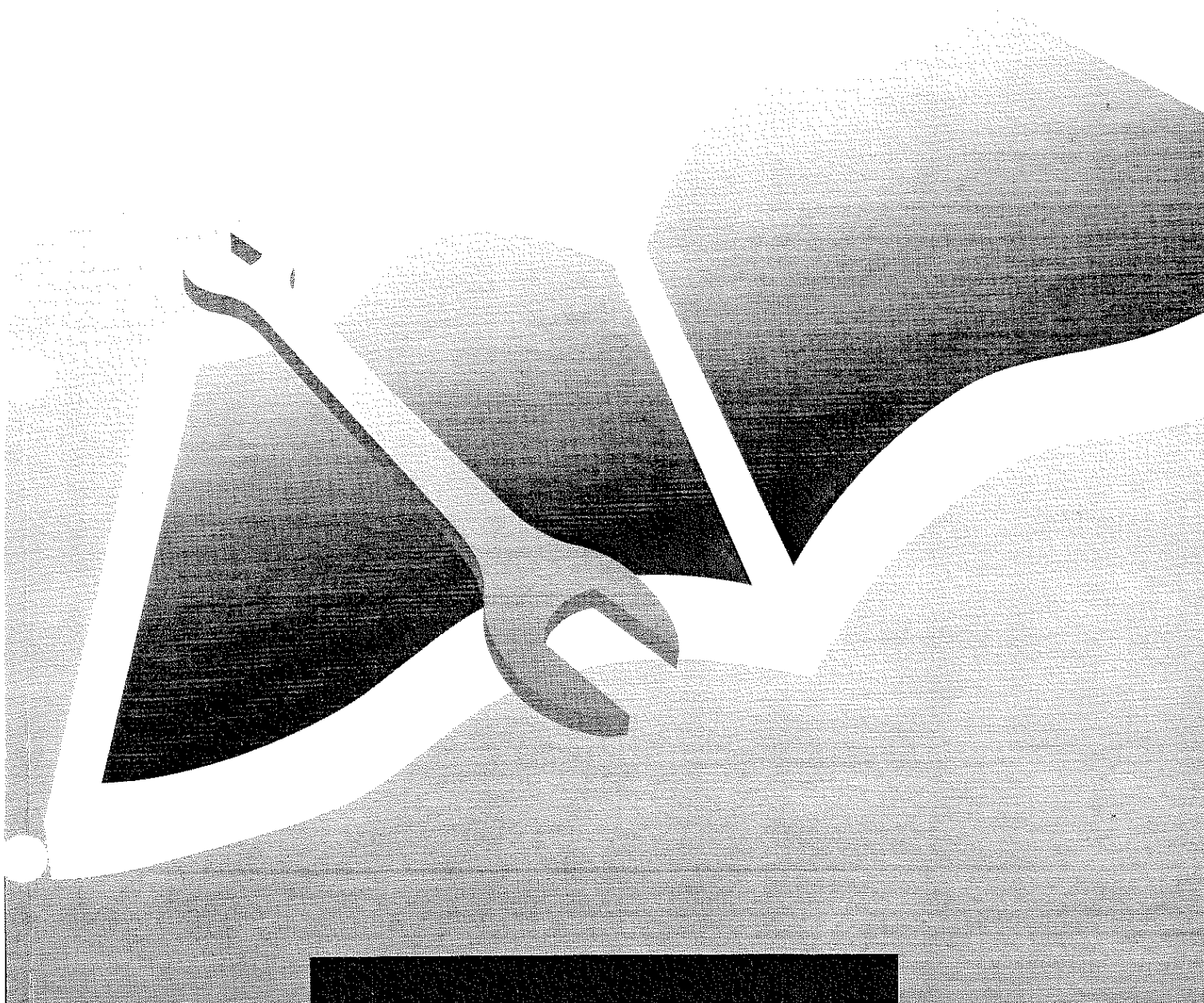

Technical assistance manual

Series 30

TIGRETRAC 2500 HST

TIGRETRAC 3800 HST

TIGRETRAC 3800 HST 4WS

SUPERPARK 3800 HST



For this edition are responsible the Service Departments
of the Antonio Carraro spa

Brochure: Cod. 4 7310 026

Drawings: R.B.S. studio
Composition: F.lli Zampieron



INTRODUCTION

Antonio CARRARO S.p.A has put much effort in to writing this shop manual regarding Tigro-ne-Superpark series 30 to inform on how to operate on the tractor in order to save you time and maximize product understanding.

This manual also contains all the information relating to the tractors, outlining in particular adjustment operations, detachment and attachment as well as disassembly and assembly instructions.

To improve and to facilitate comprehension, this manual has been supplied with a great number of figures that show not only the detachment and attachment operations, disassembly and assembly procedures as well as adjustment, but also highlights on the tools and the gauging instruments used.

Many drawings and diagrams allow a full view of the tractor components and their operation, offering a clear picture and ease, reference for the person in charge of repairing the tractor.

Safety and accident prevention

Most accidents and injuries that take place in shops are caused by the non-observance of some simple and fundamental safety and accident prevention rules.

The fundamental safety and accident prevention rules do not mean "interfering with productive process in shops but on the contrary they improve man's performances and that of the machine, to the advantage of the single worker and of the whole community".

Data contained in this manual are merely indicative and may not be up-to-date consequently to the modifications adopted by the Manufacturer, at any time, for technical or commercial reasons not to mention for the compliance to the requirements in the different countries.

General safety and accident prevention rules



Strictly observe the triangular danger sign found in this manual: it warns of situations or group of circumstances that can cause damages both to both people and things.

General information

- Perform operations by strictly observing safety and accident prevention measures.
- Do not wear loose clothing, wrist watches, rings, etc. We suggest wear ing work clothing and safety equipment such as gloves, goggles and safety shoes.
- Use tools to align holes and slots.
- For overhead hoisting, do not exceed work load limits.
- Dispose of oils in compliance with environmental regulations.

Avoid polluting the environment.

- Do not use gasoline, diesel oil or other flammable liquids to degrease or wash parts but use commercial and non-toxic solvents.
 - Wear gloves to handle metal cords or chains.
 - Handle hydraulic oil with care since it is poisonous and corrodes paint.
 - Do not perform any servicing on the tractor while engine is running, if not indicated otherwise.
 - Watch out for shearing
 - Watch out for squeezing
 - Watch out for tangling
 - Watch out for collision
 - Watch out for projection of fluids at high pressure.
 - Disconnect battery before attempting any servicing.
 - Do not operate tractor in closed premises.
- Dispose of waste fluids, used filter cartridges, oils, lubricants and grease cleaners in the most suitable way and in compliance with regulations in force.
- The collection of waste oils must be performed by authorized plants.
- Keep environment clean.
- Operations that require special care may be hazardous for the operator if not correctly performed.



TABLE OF CONTENTS

	GROUP	Page
GENERAL INFORMATION - DATA.....	00	
– Engine features		3
– Driving torques		4
– Lubricants		5
– Fixing agent		5
CLUTCH.....	10	
– Clutch technical features		6
– Disconnecting and connecting the clutch		6
– Checking the clutch		10
– Disconnecting and connecting bearing		11
– Adjustment of the clutch pedal travel		12
– Clutch equipment		12
– Troubleshooting		13
FRONT DRIVE.....	20	
– Disconnecting and connecting the front drive		15
– Connecting and disconnecting the Superpark front drive		17
– Disassembly and assembly of the Tigretrac front drive (Superpark rear)		20
– Differential unit		25
– Calculating the thickness of the support ring of the bevel pinion bearing		26
– Pinion bearing preloading		27
– Adjustment of backlash between the ring gear and pinion		27
– Differential box bearing preloading		28
– Assembly and disassembly of the differential		29
– Checking the crown wheels axial play		30
– Differential equipment		31
CENTRAL DRIVE.....	30	
– Technical features of hydrostatic unit		37
– Disconnecting and connecting the Superpark central drive		37
– Disconnecting and connecting the Tigretrac central drive with cab frame (4 uprights)		44
– Disconnecting and connecting the Tigretrac central drive with roll bar		51
– Cross-section of C.G.S. 28 hydrostatic unit		58
– Disassembly and assembly of hydrostatic unit		60
– Control of hydrostatic unit parts		63
– Troubleshooting		68
– Checking pressure of hydrostatic unit		69
– Central drive equipment		70
REAR DRIVE.....	40	
– Disconnecting and connecting the Tigretrac-Superpark rear drive		73
– Disassembly and assembly of speed gear		75
– Bevel gear adjustment differential unit		84
– Pinion bearing preloading		85
– Adjustment of play between ring gear and preloading of differential box bearings		86
– Disassembly and assembly of differential		88
– Rear drive equipment		91

TABLE OF CONTENTS



	GROUP	Page
AXLES - FRAMES	50	
– Disconnecting and connecting the Tigretrac front axle		95
– Disconnecting and connecting the Superpark front axle		97
– Disassembly and assembly of the Tigretrac front axle		101
– Disassembly and assembly of the Superpark front axle		105
– Disconnecting and connecting the Tigretrac rear axle		107
– Disconnecting and connecting the Superpark rear axle		110
– Disassembly and assembly of Tigretrac Superpark rear axle		112
– Axles and frames equipment		113
BRAKES	60	
– Description		115
– Troubleshooting		115
– Disconnecting and connecting Tigretrac - Superpark brakes		116
– Brake adjustment		117
– Handbrake stroke adjustment		117
STEERING	70	
– Technical features		118
– Troubleshooting		122
– Tigretrac steering drive cylinder overhauling		123
– Superpark steering drive cylinder overhauling		124
– Disconnecting and connecting the Tigretrac hydrostatic drive		125
– Disconnecting and connecting the Superpark hydrostatic drive		126
– Disassembly and assembly of Tigretrac - Superpark hydrostatic drive distributor		126
– Hydrodrive overpressure valve control		127
– Checking toe-in		127
– Equipment		128
HYDRAULIC SYSTEM	80	
– Technical features		129
– Troubleshooting		130
– Disconnection and connection Tigretrac hydraulic elevator		133
– Disconnection and connection Superpark hydraulic elevator		133
– Checking overpressure valve		134
– Disconnecting and connecting elevator cylinder		135
– Disassembly and assembly of elevator cylinder		136
– Equipment		136
ELECTRIC SYSTEM	85	
– Technical features		137
– RPM counter adjustment		140
– Electrical diagrams		141
AUXILIARY UNITS	90	
– Disconnecting and connecting the front PTO		148
– Disassembly and assembly of the front PTO		149
– Checking actuation pressure of the clutch unit		152
– Equipment		153
– Driving on road with reverse drive for Tigretrac 3800		159



IDENTIFICATION DATA

Location of general identification plate.

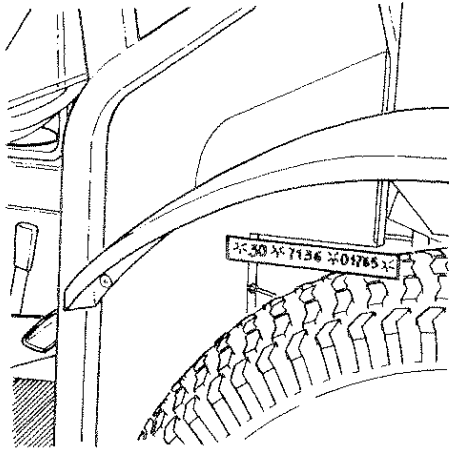

1 - Tigretrac HST: type and number of body

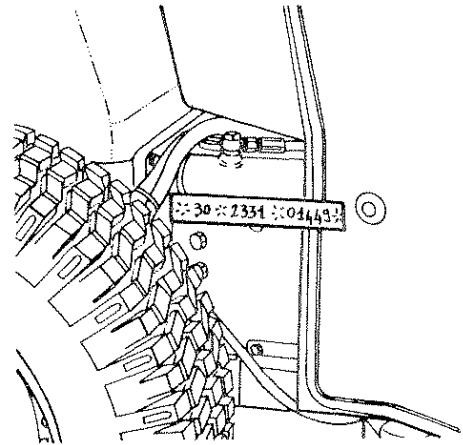

2 - Superpark HST: type and number of body

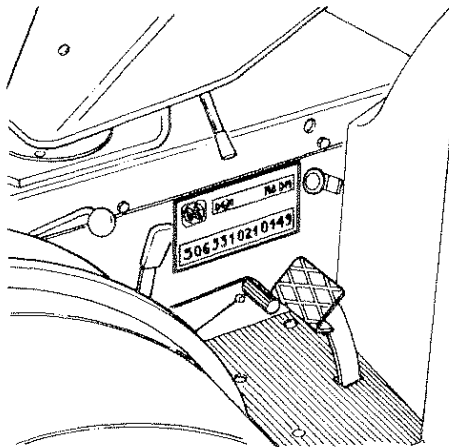

3 - Tigretrac HST: identification plate

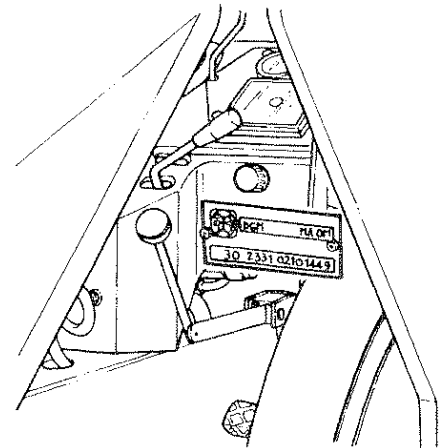

4 - Superpark HST: identification plate

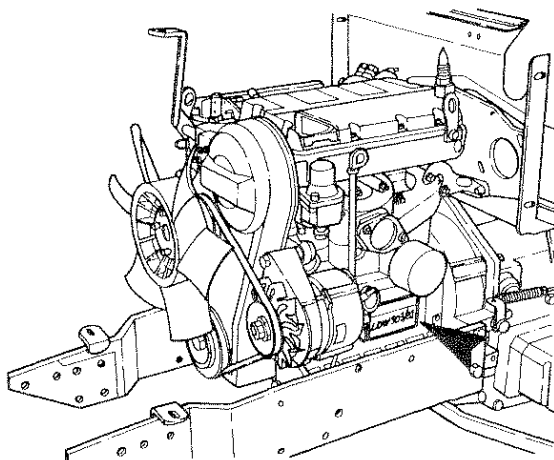

5 - Type and engine identification number

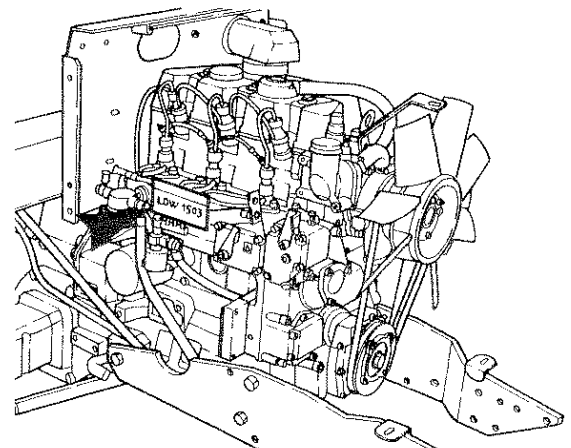

6 - Type and engine identification number

SPARE PARTS

When ordering spare parts please supply the following:

- 1) Serial number of tractor.
- 2) Name of part and code number.



GENERAL DIMENSIONS

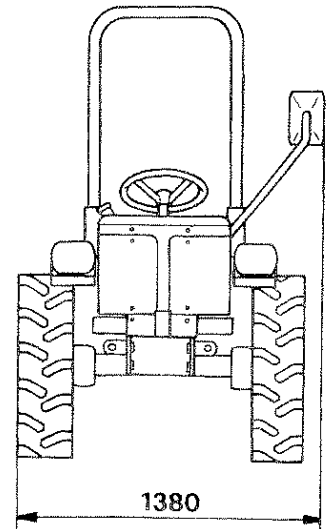
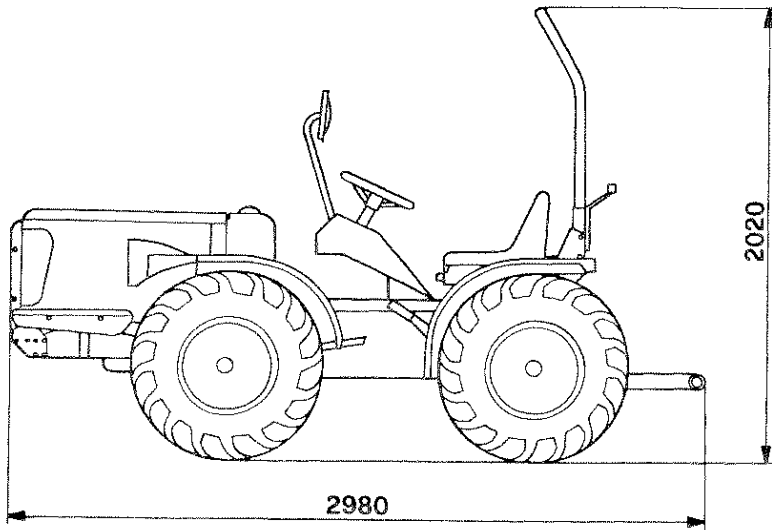

- Main dimensions of Tigretac with roll bar

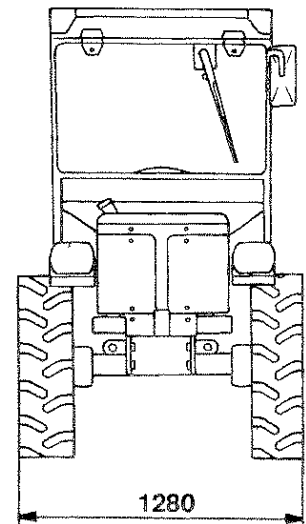
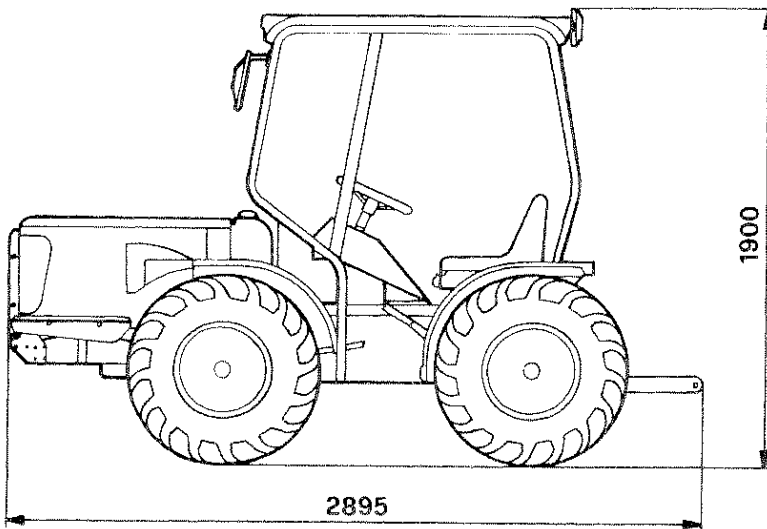

- Main dimensions of Tigretac with cab frame

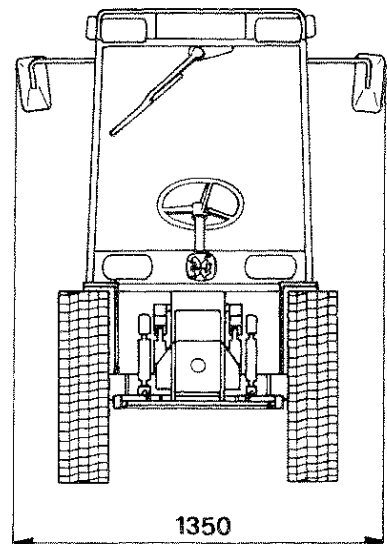
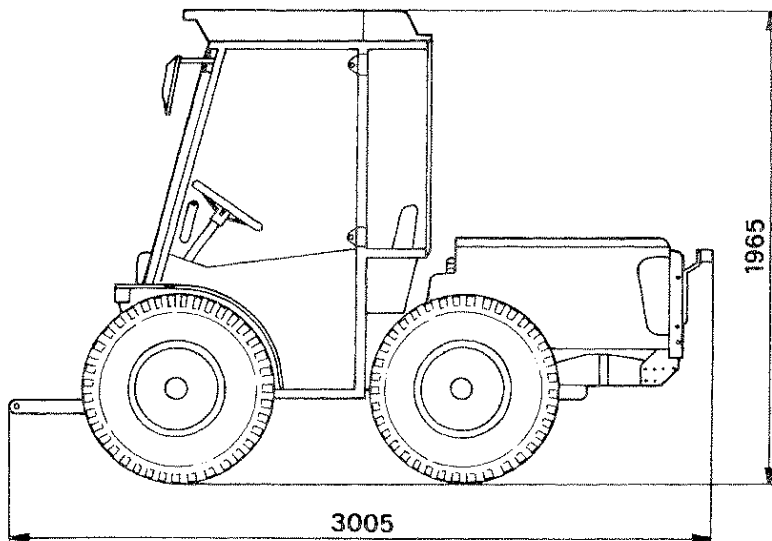

- Main dimensions of Superpark



Weights

Tractor in running order (with full tank and driver)

		Total weight	Weight of front axle	Weight of rear axle	Standard wheels (price-list)
Tigretrac 2500 HST	a	1008	550	458	6.50-16
	b	1080	616	464	
	c	1180	660	520	
Tigretrac 3800 HST	a	1062	644	418	6.50-16
	b	1134	704	430	
	c	1236	738	498	
Tigretrac 3800 HST 4 WS	b	1178	688	490	6.50-16
	c	1280	740	540	
Superpark 3800 HST	b	1090	370	720	28x9.00-15
	c	1188	406	782	

a = Tractor with roll bar
b = Tractor with cab frame (open)
c = Tractor with cab frame (closed)

TOPPING-UP

Parts to be topped-up	QUANTITY (LT)		Fuel
	LDW 903	LDW 1503	
Fuel tank	30	30	Diesel oil
Radiator, engine	2,7	2,7	GISTEDA-FLÙ
Front transmission box and hydraulic circuit	6,5	6,5	15/40 ESSO UNIFARM
Rear gearbox and hydrostatic circuit	8,5	8,5	10/30 ESSO UNIFARM
Windscreen cleaner tank	0,5	0,5	water
Engine sump and oil filter	2	4,15	15/40 ESSO UNIFARM

ENGINE FEATURES

Lombardini



Type of engine		LDW 903 FOCS	LDW 1503 CHD
Cylinders	Nr.	3	3
Bore	mm	72	88
Stroke	cm	75	85
Engine power	cm ³	916	1551
RPM		3000	3000
Power KW/CV		15.5/21	26.5/36
Max. torque Nm	(rpm)	56.6/2200	99/2100
Cooling		Water	Water



DRIVING TORQUES

Indicative values for maximum driving torques in Nm - Kgm

Expected friction factor = 0.14

NAME	RESISTANCE CLASS					
	 8.8		 10.9		 12.9	
Diameter x p (mm)	Nm	Kgm	Nm	Kgm	Nm	Kgm
M 5 x 0.8	5.9	0.6	7.84	0.8	9.9	1.01
M 6 x 1	10.1	1.03	14.3	1.46	17.2	1.75
M 8 x 1	25.5	2.6	36.3	3.7	43.1	4.4
M 8 x 1.25	24.3	2.48	34.2	3.49	41.1	4.19
M 10 x 1.25	50.9	5.2	71.5	7.3	85.3	8.7
M 10 x 1.5	48.7	4.97	68.6	7	82	8.37
M 12 x 1.5	87.2	8.9	122.5	12.5	147	15
M 12 x 1.75	82.9	8.46	116.6	11.9	140.1	14.3
M 14 x 1.5	140.1	14.30	196	20	235.2	24
M 14 x 2	131.9	13.46	195.2	19.92	222.5	22.70
M 16 x 1.5	210.7	21.5	294	30	352.8	36
M 16 x 2	199.9	20.4	282.2	28.80	339.1	34.6
M 18 x 1.5	303.8	31	421.4	43	509.6	52

Special screws

Description	Pitch diameter - mm	Driving torque	
		Nm.	Kgm.
Differential box ring gear fastening screws	M 10 x 1.25	83	8.5
Wheel fastening nuts or screws	M 14 x 1.5	137	14
Front axle semishaft fastening nuts	M 18 x 1.5	88	9
Hydrostatic unit maximum valve cap	—	68.6	7
Hydrostatic unit feed valve cap	—	39.3	4

UNIONS - NIPPLES (with Cu washer)

RATED DIAMETER	HEX KEY (mm)	DRIVING TORQUE	
		Nm	Kgm
M14x1.5	17-19	44	4.5
M16x1.5	22-24	59	6.0
M18x1.5	24-27	59	6.0
M20x1.5	27	59	6.0
GAS 1/4»	17-19	44	4.5
GAS 3/8»	22-24	59	6
GAS 1/2»	27	59	6



LUBRICANTS

- ESSO UNIFARM 15W 40 oil
 - Front gear box (hydraulic system tank)
 - Engine (Diesel)

- ESSO UNIFARM 10W 30 oil
 - Rear gear box (speed gear and hydrostatic tank)

- FIAT ZETA 2 GREASE
 - Splined section bars
 - Joints - Semishafts

- GP GREASE
 - On different greasing points (greasing nipples)

- TECNOLUBE POLIMER 400 GREASE
 - Bushings
 - Roller bearing cages

- ESSO BEACON 2 GREASE
 - Accelerator drive wires - locking

- GISTEDA-FLU ANTIFREEZE LIQUID FEATURES

- Use Percentage:
- 18% GISTEDA FLU for temperatures up to - 8°C
 - 28% GISTEDA FLU for temperatures up to - 13°C
 - 36% GISTEDA FLU for temperatures up to - 20°C
 - 40% GISTEDA FLU for temperatures up to - 24°C
 - 50% GISTEDA FLU for temperatures up to - 38°C

THREAD LOCKERS AND RETAINERS

For the assembly use the products indicated or other having equivalent features:

RTV 1473 BLACK ANGST-PFISTER DOPE

- joints - packings
- speed gear box cover
- covers - front axles - rear axles
- flanges - covers

LOCTITE 242

- Average locking and sealing of threaded parts in general
- naphtha tank support screws
- anchoring dowels - joints

LOCTITE 270

- High resistance fastening, locking and sealing of stud bolts, nuts and screws
- brake jaws stop plate stud bolts

LOCTITE 510

- Sealing of surfaces
- naphtha tank float packing
- Non-threaded plugs

Better - AREXONS

- liquid packing
- threaded plugs
- water temperature indicator on engine-radiator



Disc and gearbox-clutch mechanism

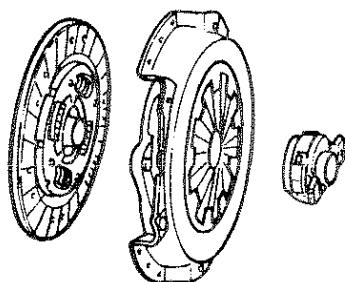

OP.1166

Description

Dry, single-plate type with diaphragm spring. Features mechanical disengagement. The clutch is almost maintenance-free, it requires simple adjustment and periodical lubrication of the disengagement controls.

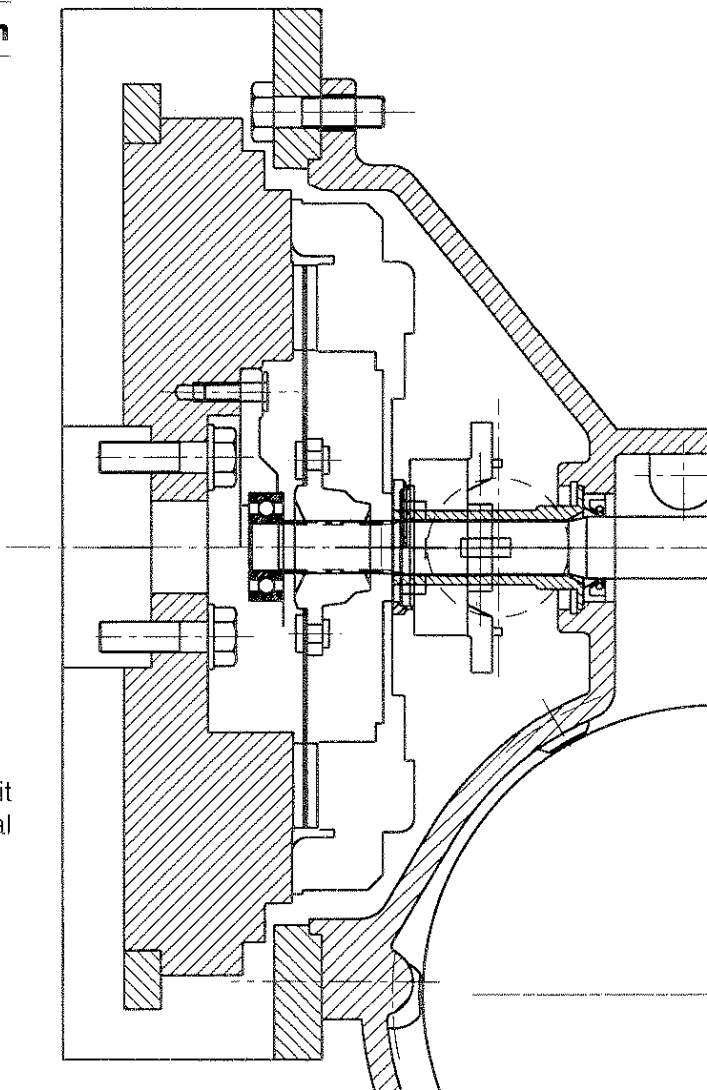

- Engine clutch assembly

Technical features

Tractor type		2500 - 3800
Type of clutch	code name	40211010 VALEO 176676 AD
Clutch mechanism	code name	40210004 VALEO 742906 FD
Thrust bearing	code	5073504
Disc diameter	mm	181,5
Rated thickness	mm	8,6 ± 0,1
Admitted thickness of disc	mm	6,0
Type of friction material		VALEO F 202



Disconnecting - connecting

Clutch is accessed by separating the whole engine from the transmission box.

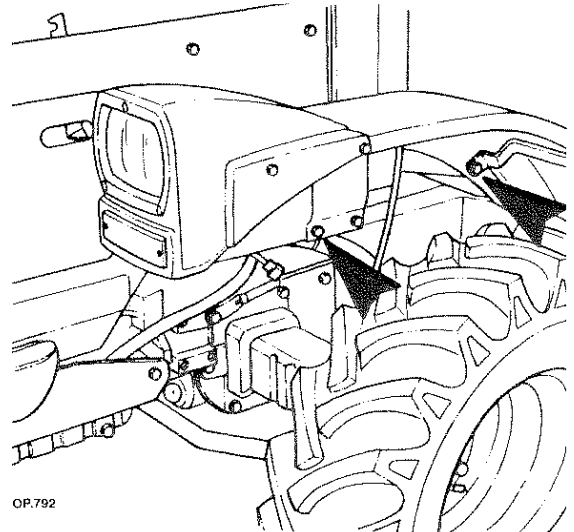

3 - Loosen the screws and remove the front fenders.

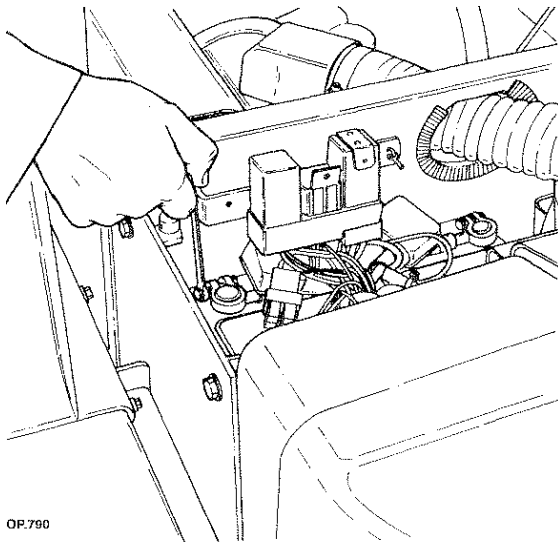

1 - Loosen the cable from the battery and insulate it.

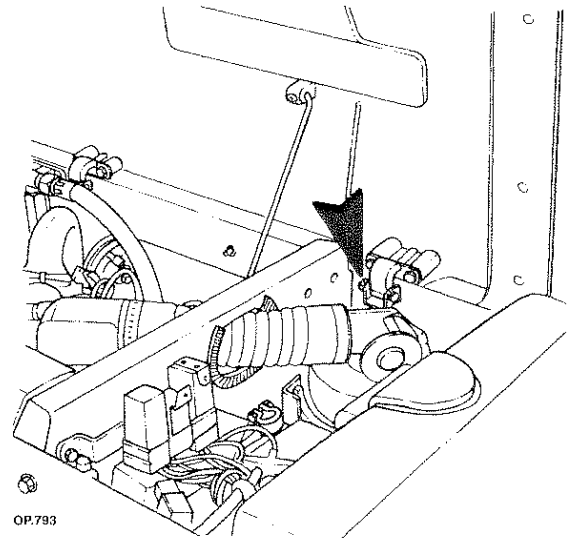

4 - Loosen the screws and remove the casing (hood).

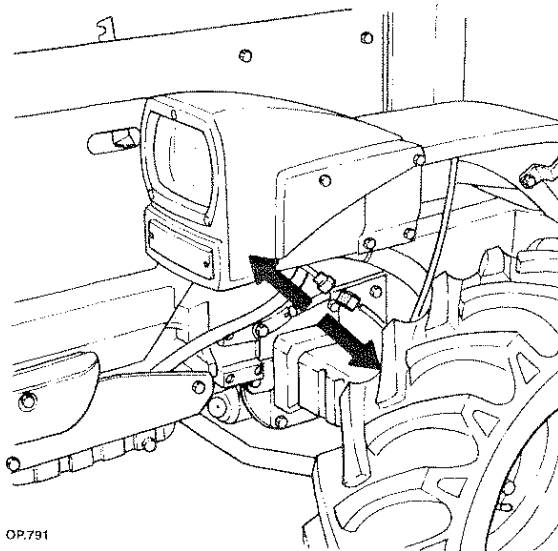

2 - Remove the electrical connections from the lights.

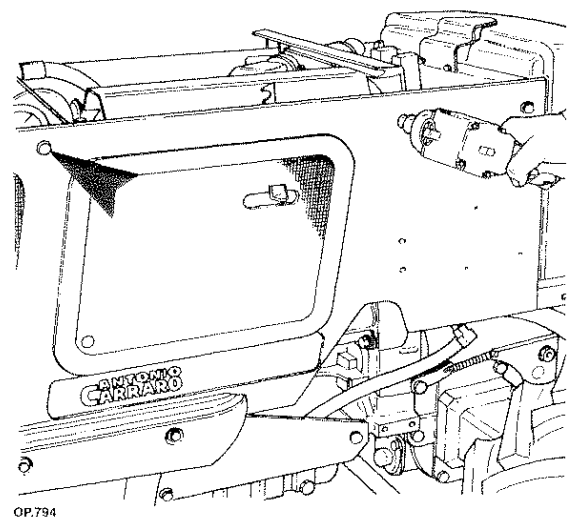

5 - Loosen the screws and remove the muffler hood and hood fastening.

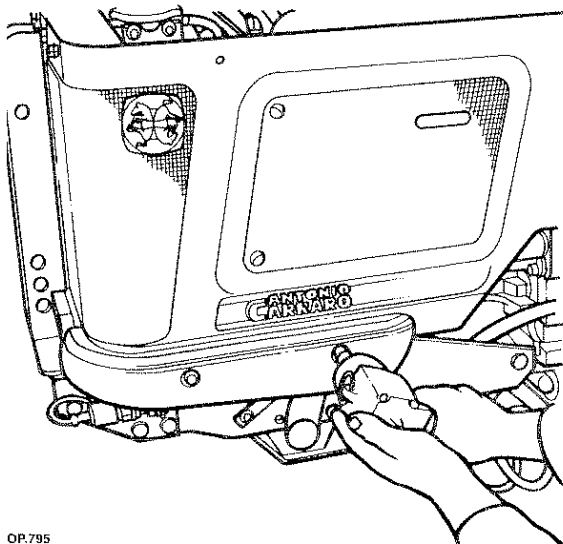

OP.795

6 - Loosen the screws and remove the fenders.
7 - Remove the windshield washer tank (Superpark only).

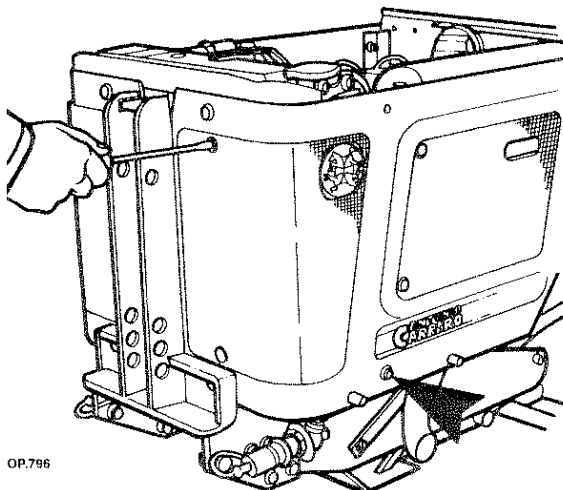

OP.796

8 - Detach the front grille, loosen the screws and remove the r.h. and l.h. sides.

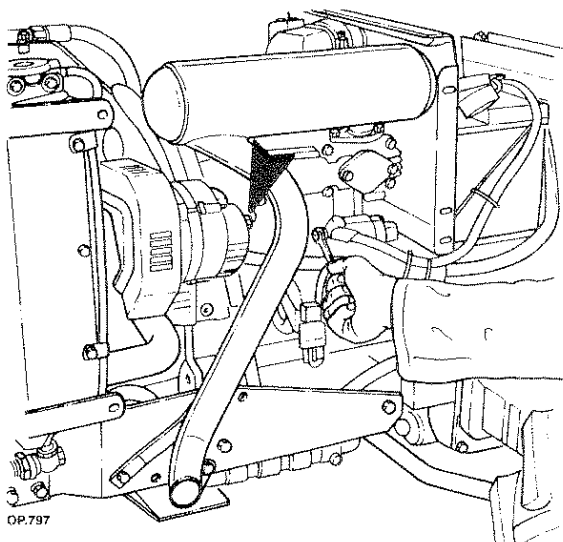

OP.797

9 - Detach the relay support and the electrical connections on the engine.

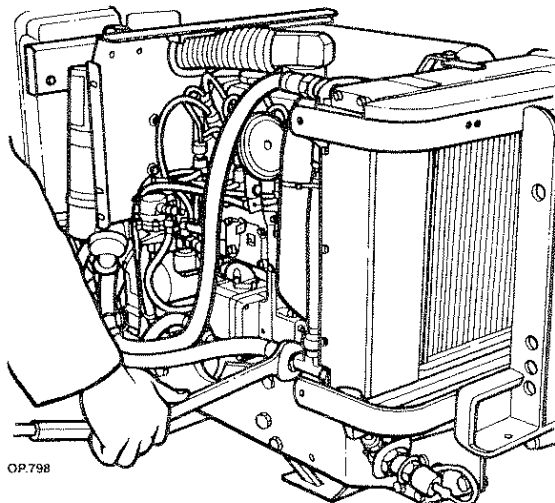

OP.798

10 - Loosen the hydraulic tube unions of the exchanger and plug holes with stoppers.

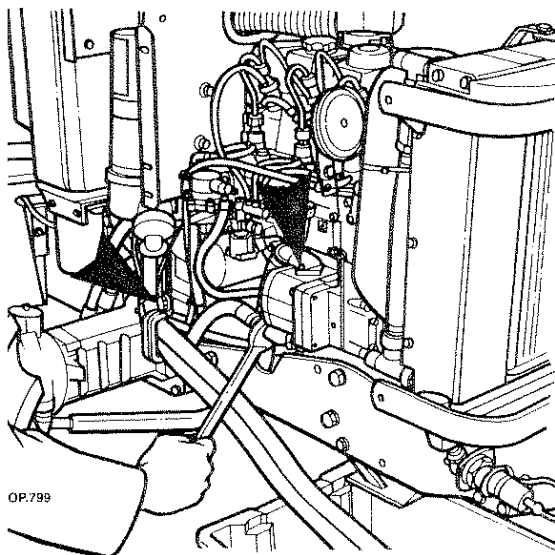

OP.799

11 - Detach the delivery and suction tubes of the hydraulic pump as well as the retainer hose clamps.

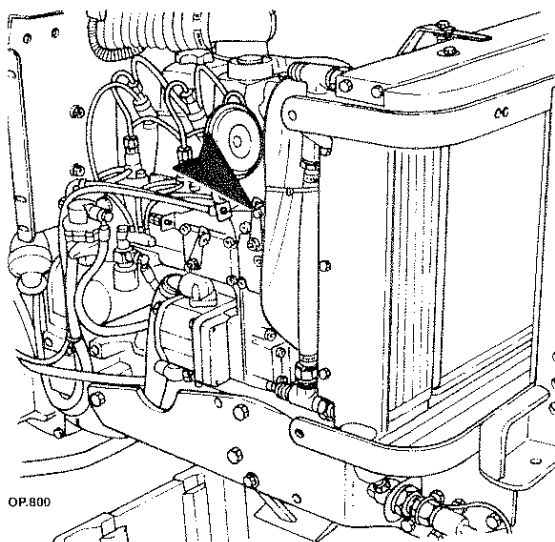

OP.800

12 - Loosen the terminals and remove the accelerator needle.

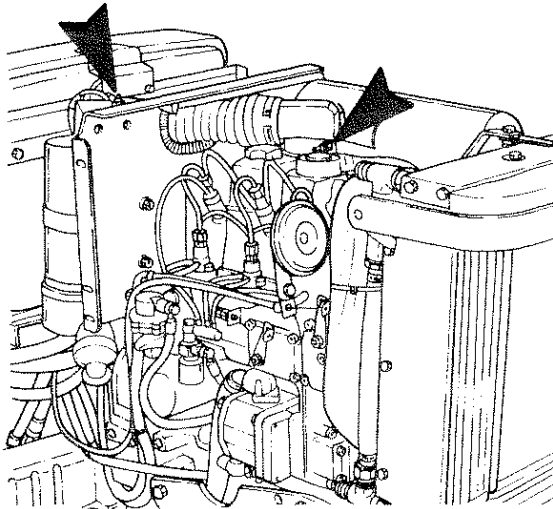

OP.801

13 - Loosen the suction tube and filter hose clamps and remove the whole suction tube.

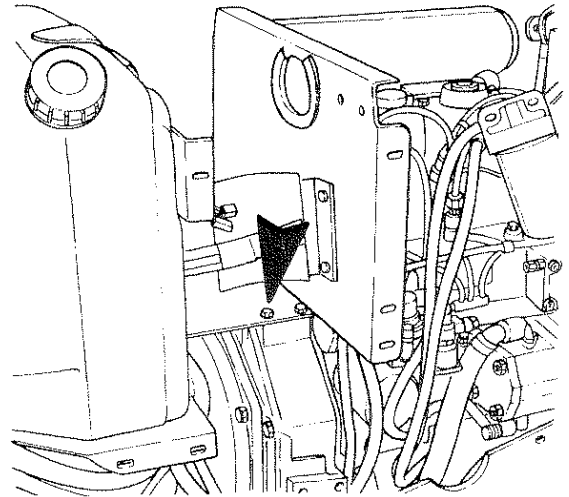

OP.804

16 - Loosen the screws and remove the side wall (remove the discharge end on 2500).

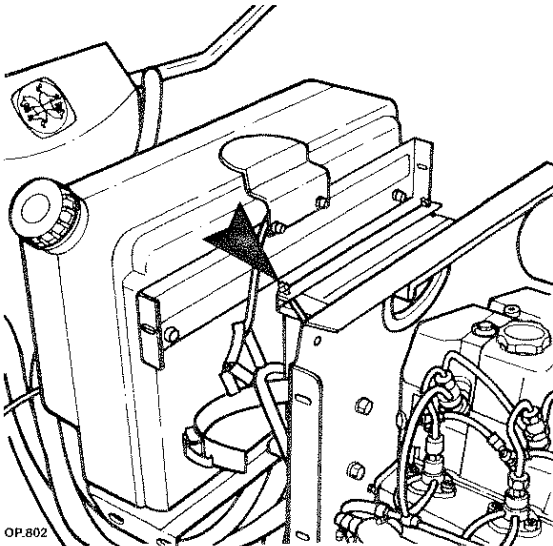

OP.802

14 - Loosen the couplings and remove the battery.

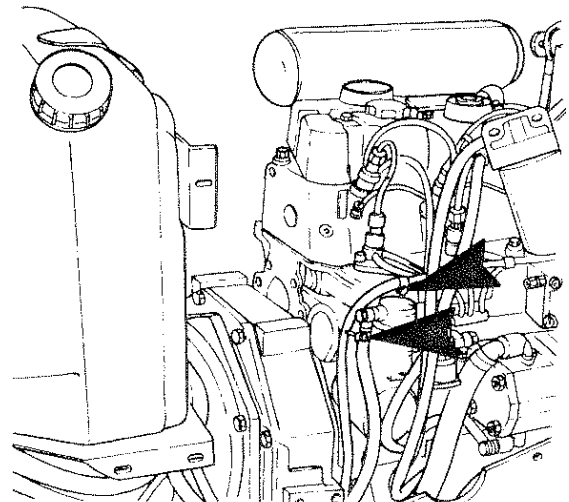

OP.805

17 - Loosen the hose clamps and remove the naphtha tubes of the pump A.C. and the injector pump.

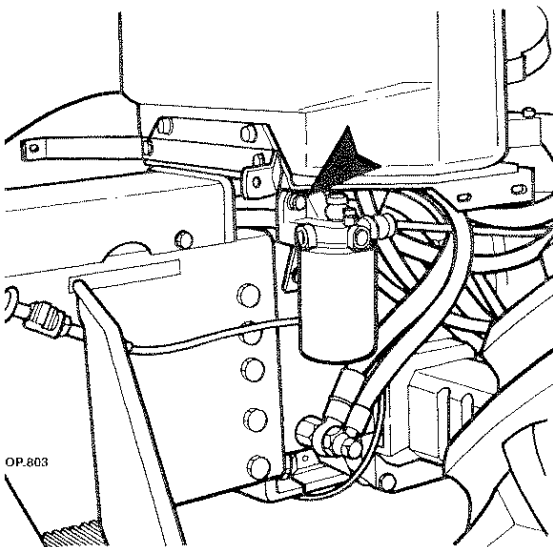

OP.803

15 - Loosen the screws and remove the naphtha filter.

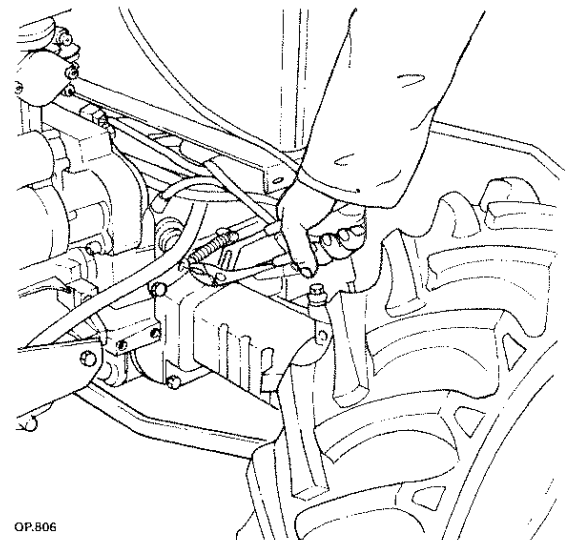

OP.806

18 - Remove the clutch pedal return spring.

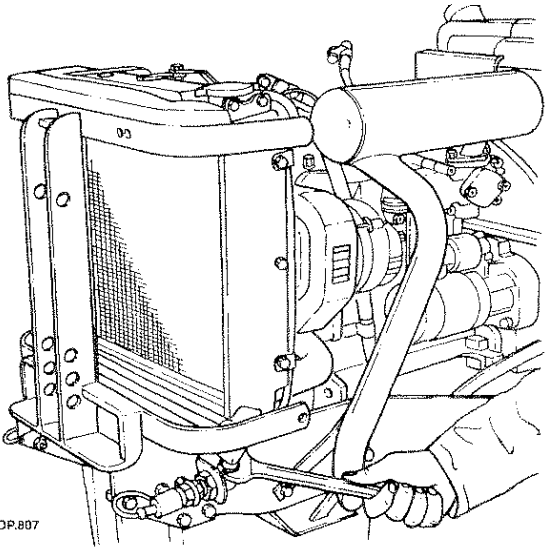

OP.807

19 - Loosen the hydraulic inlet couplings.

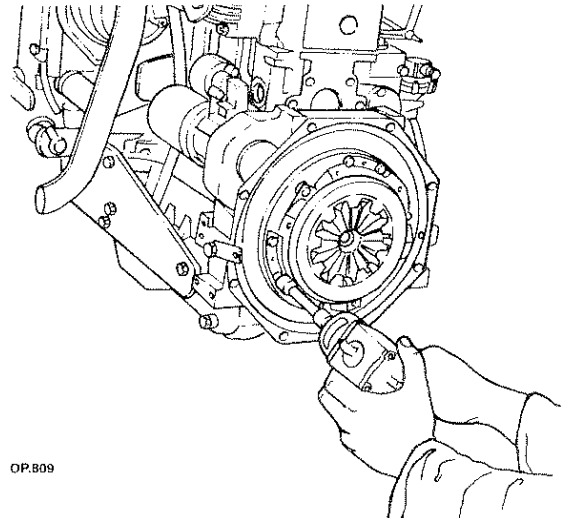

OP.809

22 - Loosen the screws and detach the clutch disc mechanism from the engine flywheel.

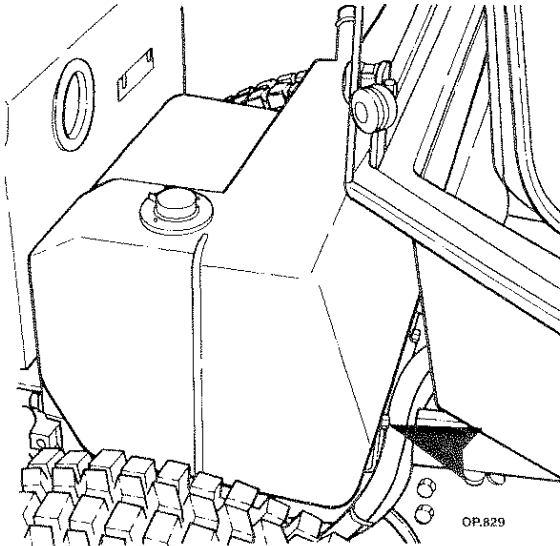

OP.829

20 - Loosen and remove the tank (only Superpark).

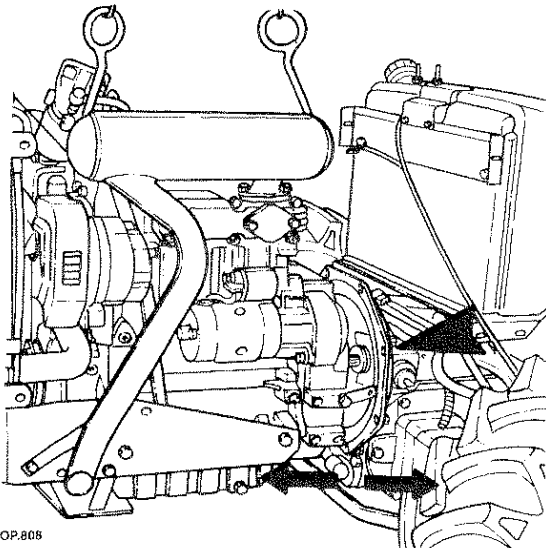

OP.808

21 - Anchor the engine, loosen the screws and separate the engine from the transmission box.

**WARNING - DANGER**

Perform operations by strictly observing accident prevention regulations.

- Do not use gasoline, diesel oil or other flammable liquids to degrease or clean parts but use commercial non-toxic solvents instead.

CHECKING THE CLUTCH

1 - Check that the friction packings of the driven disc are not excessively worn out and that they are not scored.

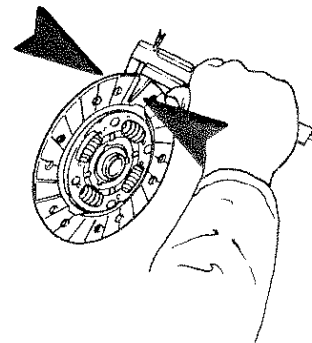

OP.810

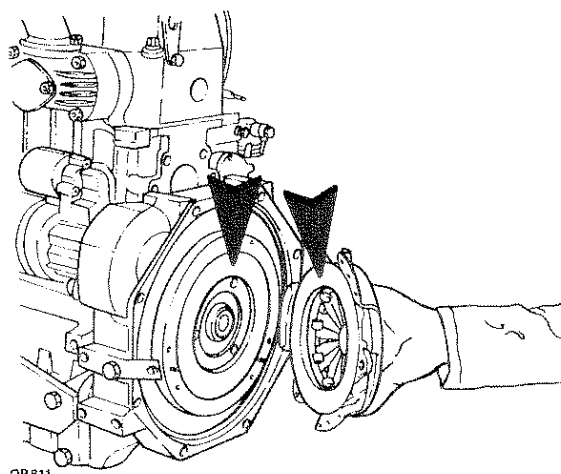

2 - Make sure that the sliding surfaces of the disc thrusting plate and the engine flywheel are not scored nor burnt. If they are, we suggest to replace the disc and the clutch mechanism and to grind the flywheel.

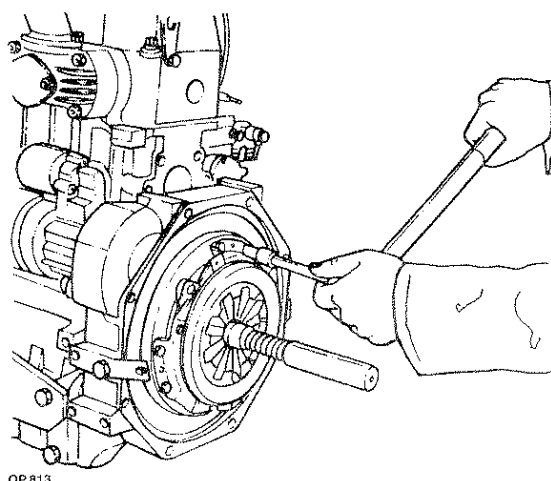

b - Mount the clutch onto the flywheel using tool no. 27981072 to align the driven disc.
c - Observe the driving torques listed at pages 4.
d - Re-assemble the whole by proceeding inversely as to the description for the disassembly.
e - Grease the thrust bearing fork driving shaft and the hub on which it slides.

CONNECTING THE CLUTCH

Before connecting the clutch again, first check:

a - the conditions of the thrust bearings and that of the drive shaft support bearing on the main gearbox or on the flange of the engine shaft. These bearings must not be damaged nor be noisy. If they are, then they should be replaced.

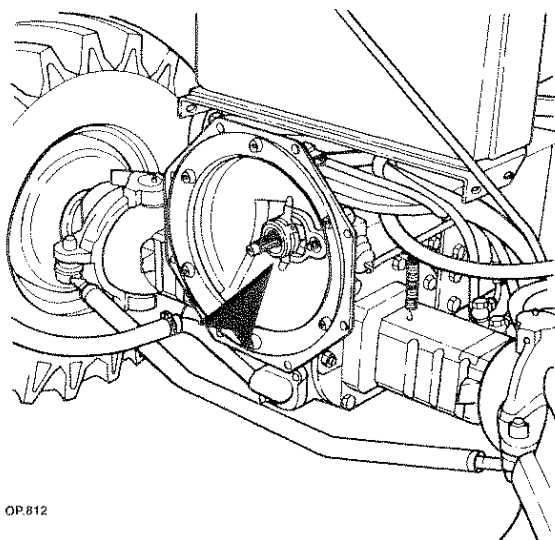

OP.B12



WARNING - DANGER



Perform operations by strictly observing accident prevention regulations.
 - Use tools to align holes and slots not hands.

DISCONNECTING AND CONNECTING THE BEARING

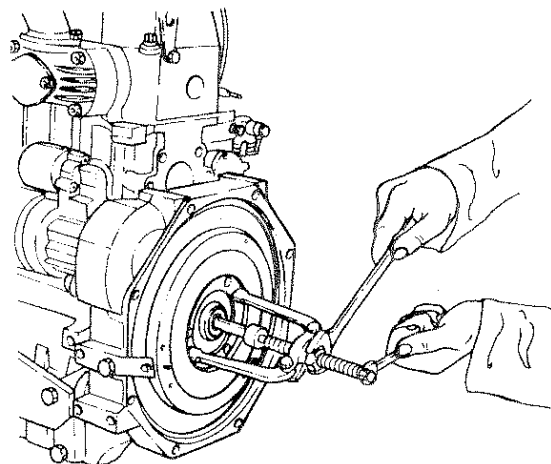

OP.B14

1 - Remove the bearing with extractor AT 37981216 and adapter AT37981222.
2 - Mount bearing using a suitable pad.



ADJUSTMENT OF THE CLUTCH PEDAL TRAVEL

The idle stroke of the clutch pedal is abt 15 mm long corresponding to a space of abt 1 mm that is present between the thrust bearing and the friction ring of the flange that controls the disengagement of the clutch. Should the idle stroke be less than the one said due to the wear of the driven disc, it is then necessary to restore the original operating conditions by adjusting the tie-rods or push-rods.

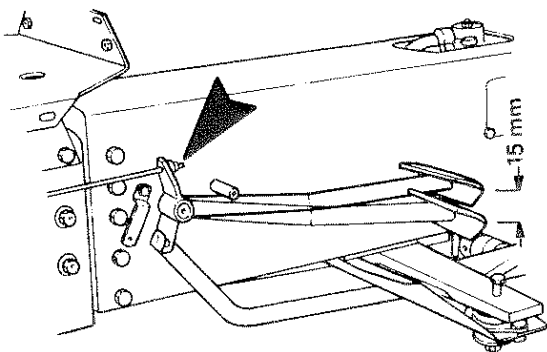

OP.1167

- Checking and adjustment of the play of the Tigretac clutch.

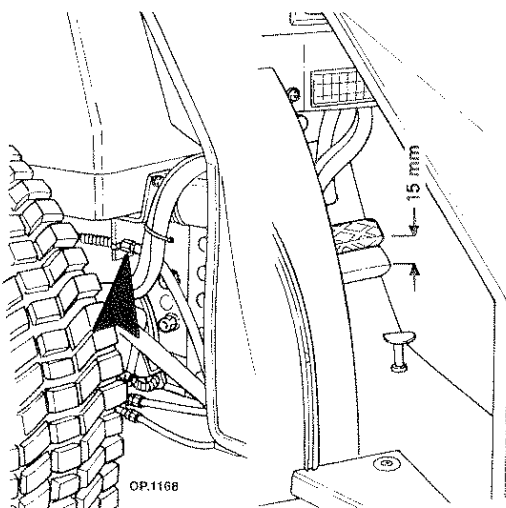

OP.1168

- Checking and adjustment of the play of the Superpark clutch.

CLUTCH EQUIPMENT

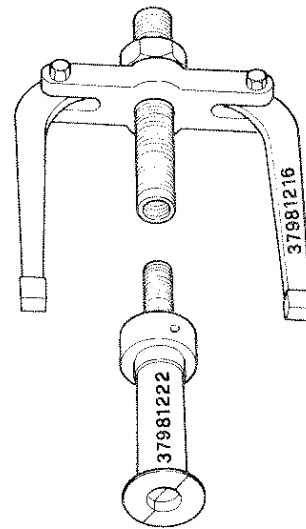

AT.001

1 - Combined puller to remove the bearing from the engine shaft AT. 36981216 - AT. 37981222.



AT.199

2 - Tool for the alignment of the clutch unit to the gear engine axis.



CLUTCH

Troubleshooting

Trouble	Probable cause	Check	Solution
Clutch slips.	Lubricant on clutch disc.	Check seal rings of main engine shaft.	Clean parts in contact with clutch seals with petrol and replace packings.
	Worn out clutch disc.	Check thickness of clutch disc and the operating condition of the clutch mechanism.	Replace disc and mechanism.
The clutch does not disengage while engine is running and the gears do not engage smoothly.	Faulty clutch mechanism	Check mechanical controls, cables and sheathings.	Adjust the clutch pedal stroke. Replace mechanism together with disc.
The clutch jerks.	Deformed surface of disc.	Check the efficiency of the disc and look for burns on the contact surface of the disk (engine flywheel and mechanism).	Replace disc and clutch mechanism and recondition the engine flywheel.
Noisy clutch.	Faulty clutch or worn out parts.	Check clutch disc Flexible coupling springs.	Replace disc.
Hard clutch pedal.	Seizing of the pump piston. Hardening of the outer controls. hardening of the pedal hinge.	Check the hinges and lubricate.	Lubricate controls.



FRONT DRIVE ASSEMBLY

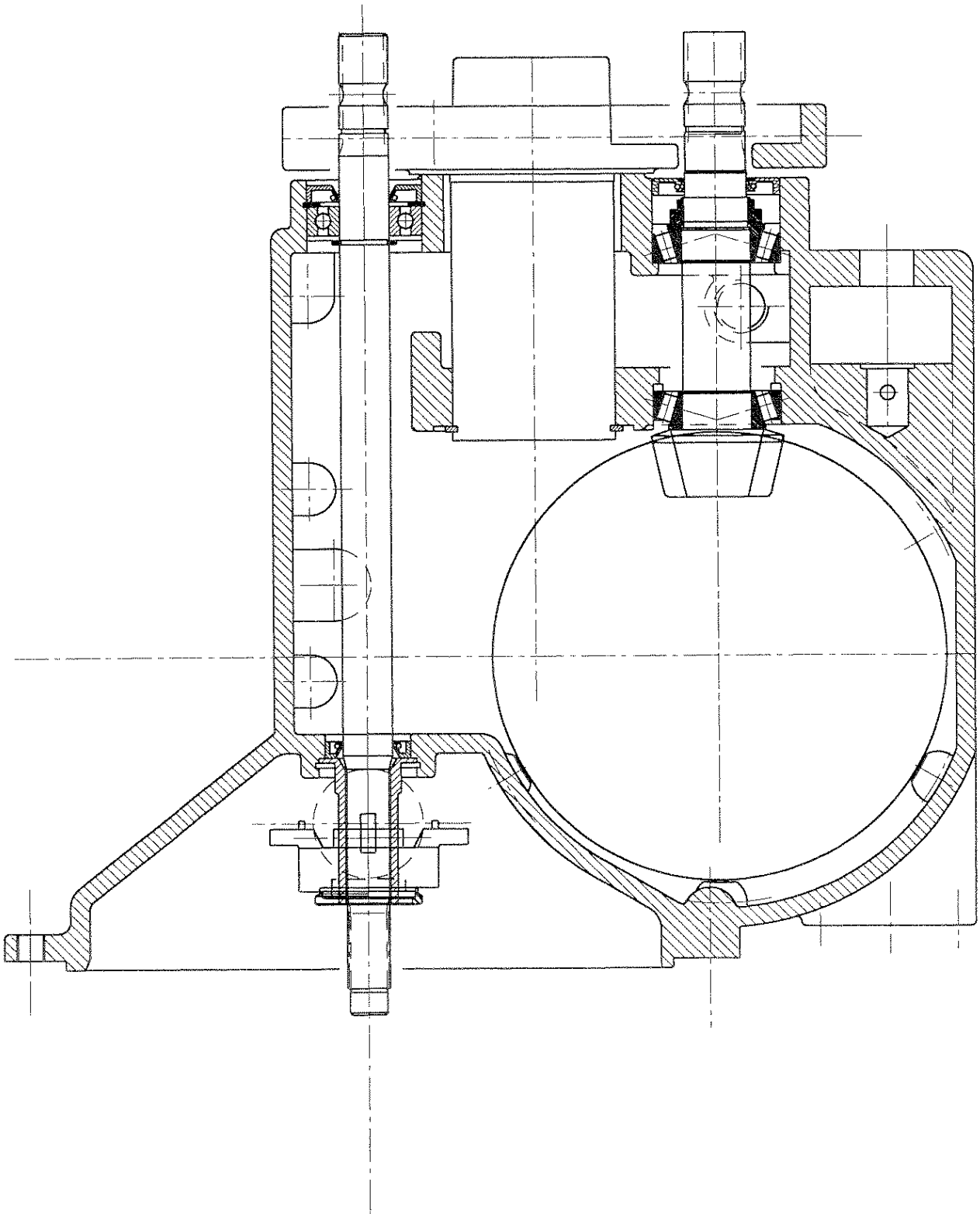



FRONT DRIVE

Disconnection and connection

A - Tigretrac

To have access to the front drive proceed as follows:

1 - Proceed as indicated in the pictures regarding the disconnection of the clutch unit steps 1 - 20 page 7 - 8 - 9 - 10.

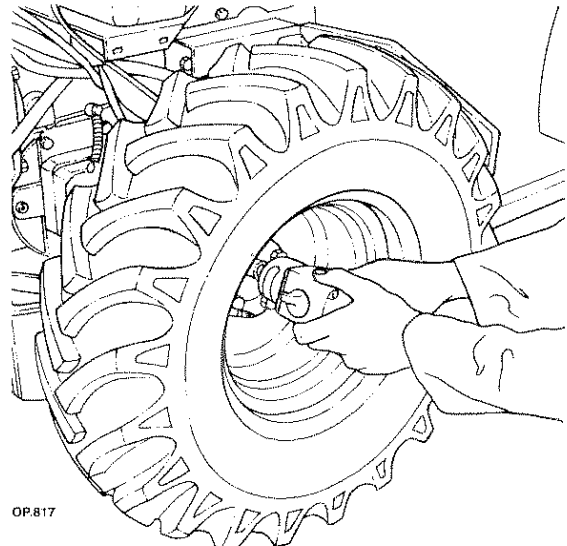

OP.817

4 - Loosen the screws and remove the front wheels.

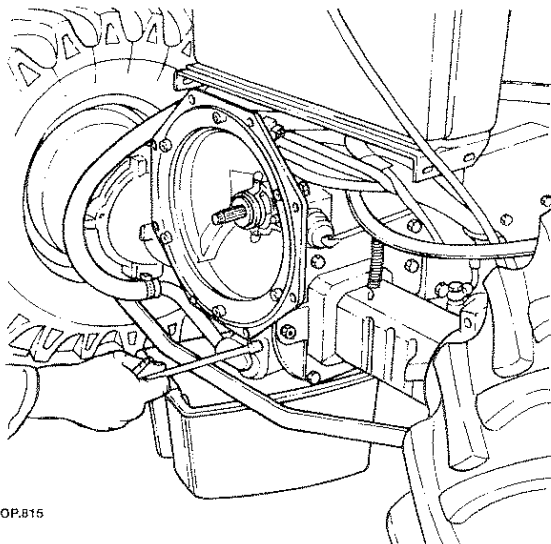

OP.815

2 - Loosen the screws and remove the hydraulic system filter. To drain, collect the oil in a specific container.

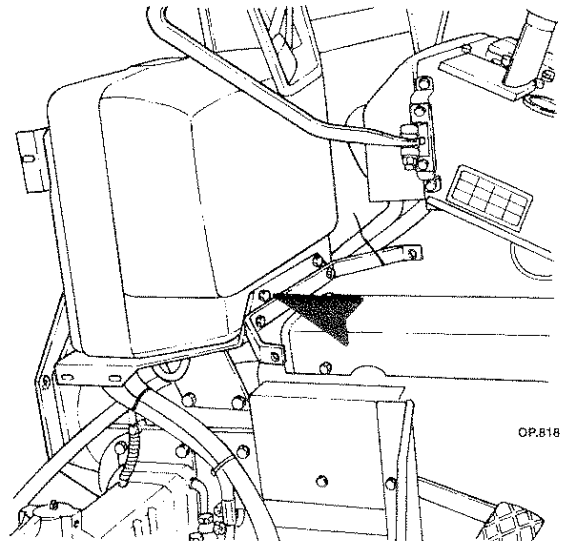

OP.818

5 - Loosen the screws and remove the naphtha tank.

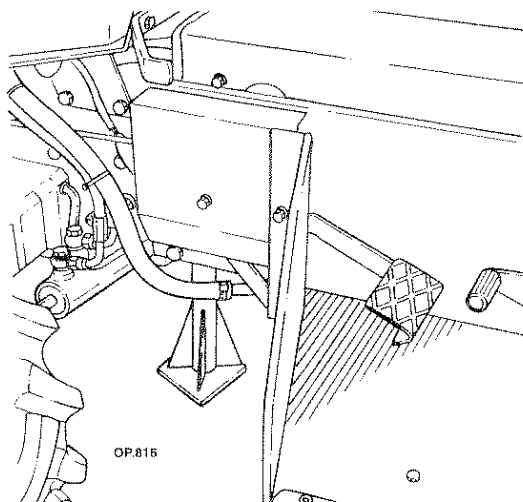

OP.816

3.- Place a horse underneath the central drive on the front side.

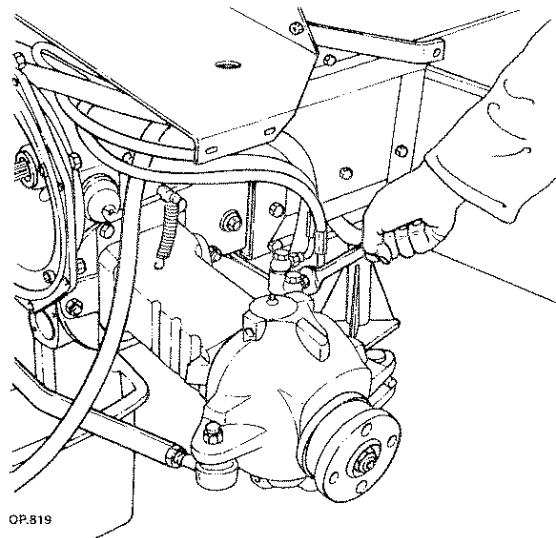

OP.819

6 - Loosen the union on the steering cylinders and plug holes with plastic stoppers.

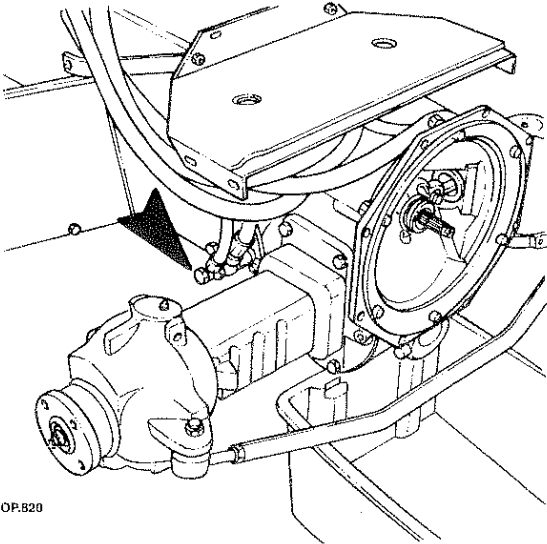

OP.820

7 - Loosen the hydraulic system drain unions.

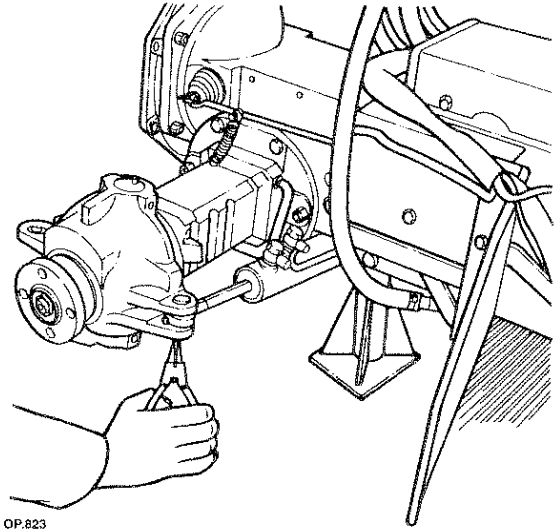

OP.823

10 - Remove the spring pin and the hydrodrive cylinder pin spring retainer ring.

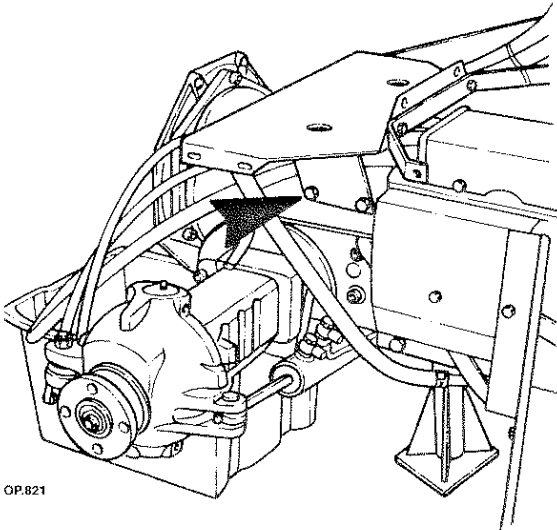

OP.821

8 - Loosen the screws and remove the tank support.

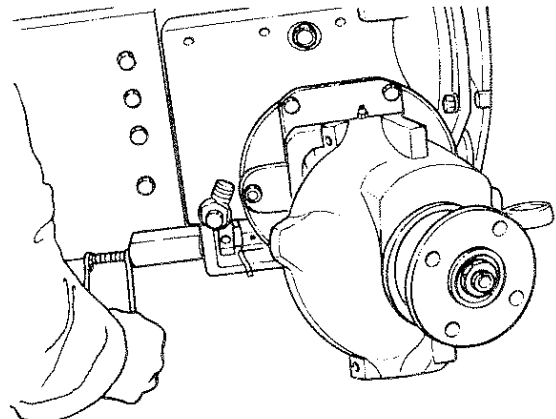

OP.824

11 - Remove the pin from the transmission box using the tool AT 2.7981.314.

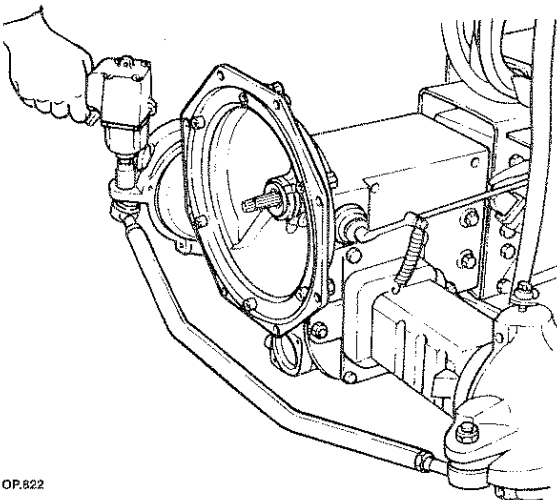

OP.822

9 - Loosen the nuts and remove the steering coupling bar.

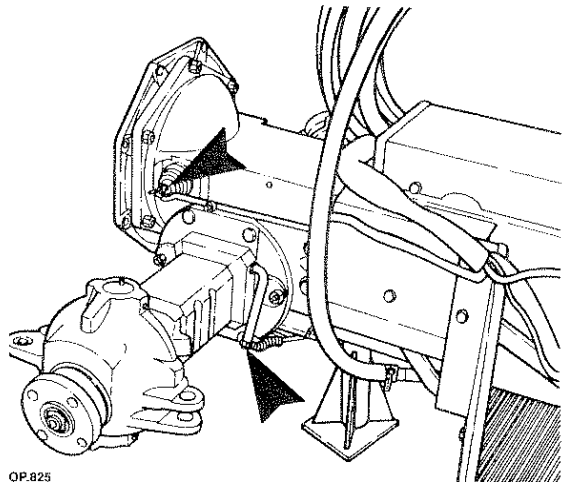

OP.825

12 - Loosen the terminal and remove the locking wire and remove the clutch rod retainer split pin.

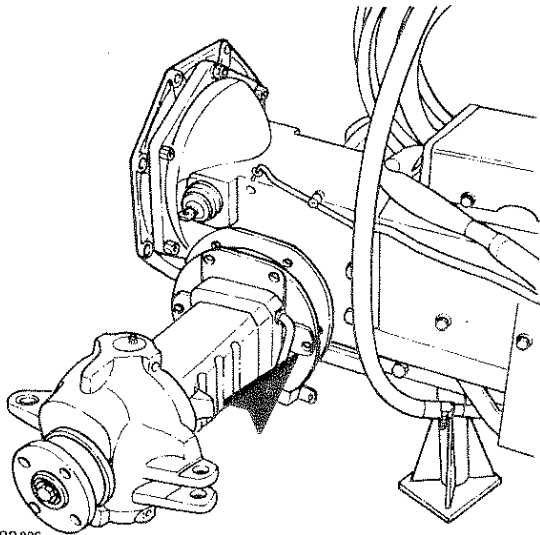

OP.826

13 - Loosen the screws and remove the axle on the differential locking side along with possible adjustment shims.

14 - Loosen the screws and remove the opposite axle along with the complete differential unit.



WARNING - DANGER



Perform operations by strictly observing accident prevention regulations.

- Wear safety clothing such as, gloves and safety shoes.
- Do not align slots with hands but use specific tools instead.
- Use suitable hoisting means.

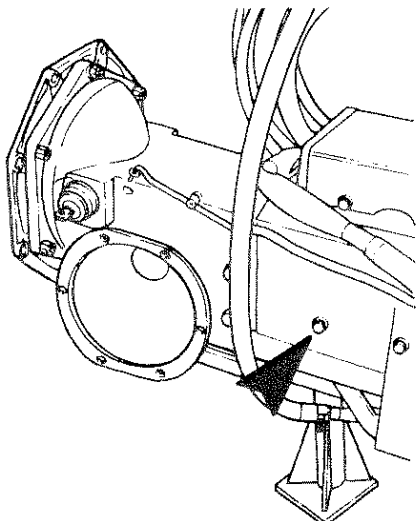

OP.827

15 - Loosen the clutch pedal protection.

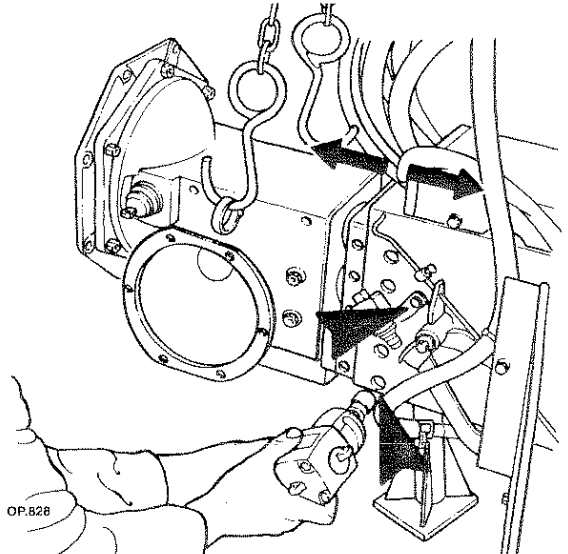

OP.828

16 - Loosen the screws and remove the start enable.

17 - Loosen the fastening screws of the front unit from the main body and remove the front transmission box.



WARNING - DANGER



Keep environment clean. Dispose of waste fluids, used filter cartridges, oils, lubricants and grease cleaners in the most suitable way and in compliance with regulations in force. The collection of waste oils must be performed by authorized plants.

B - Superpark

Proceed as indicated in the pictures regarding Tigretac steps 1 - 3 page 15.

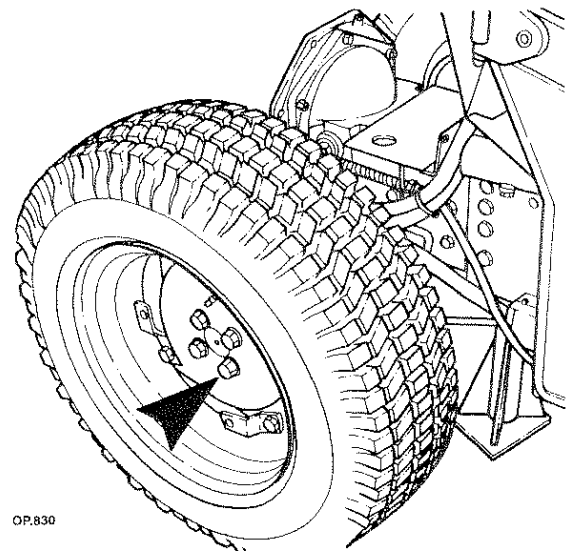

OP.830

4 - Loosen the screws and the nuts and remove the wheels.

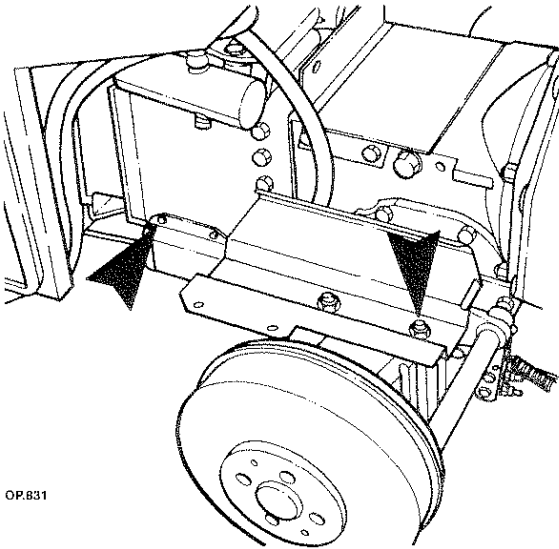

OP.831

5 - Loosen the screws and remove the battery supports and the tube protections.

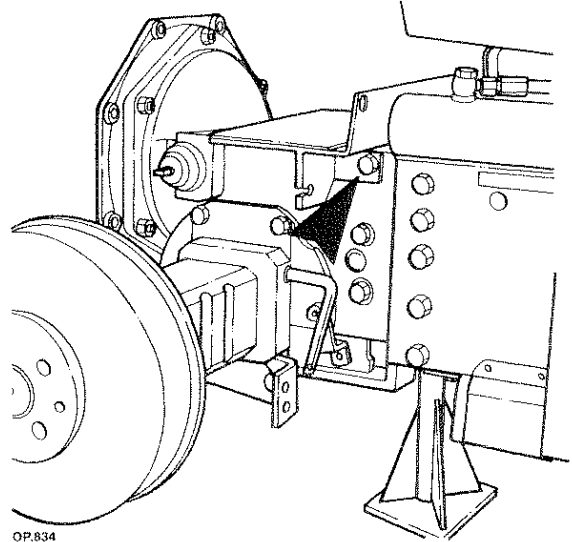

OP.834

8 - Loosen the screws and remove the support of the tank.

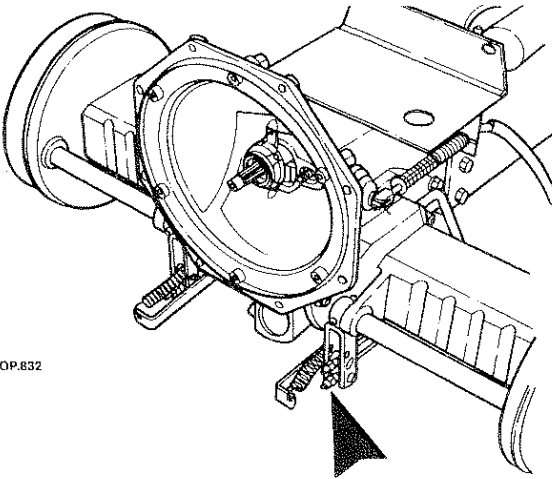

OP.832

6 - Loosen the nuts and the lock nuts of the hand brake and service brake cords and partly remove the wires and the sheathings.

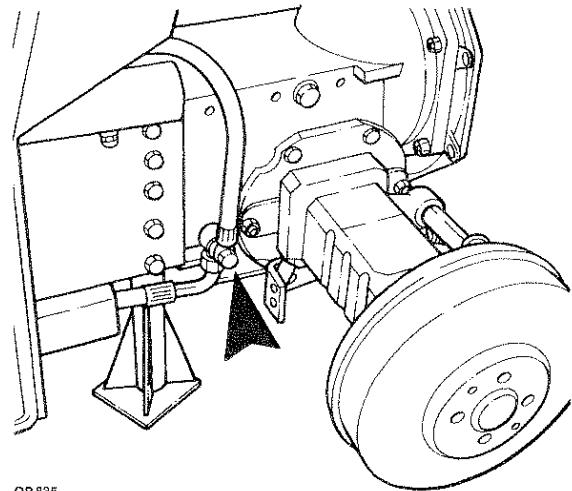

OP.835

9 - Loosen the hydraulic system tank.

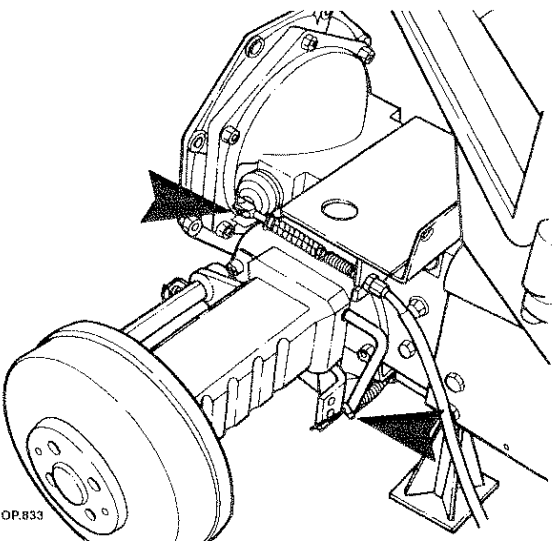

OP.833

7 - Loosen the clamp and remove the split pin of the clutch cord.

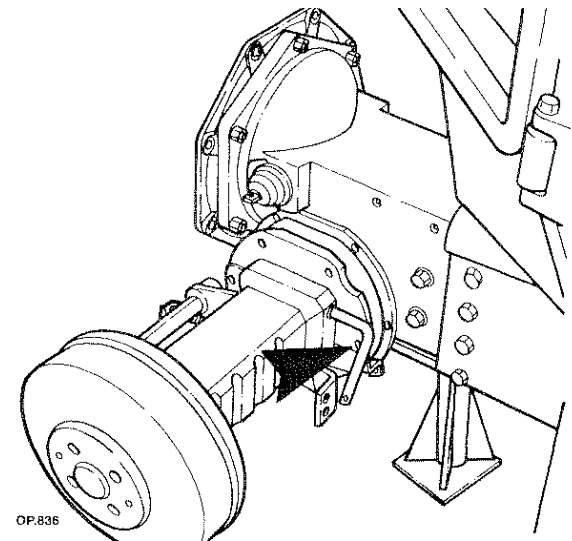

OP.836

10 - Loosen the screws and remove the r.h. and l.h. axle along with the shims and differential unit.

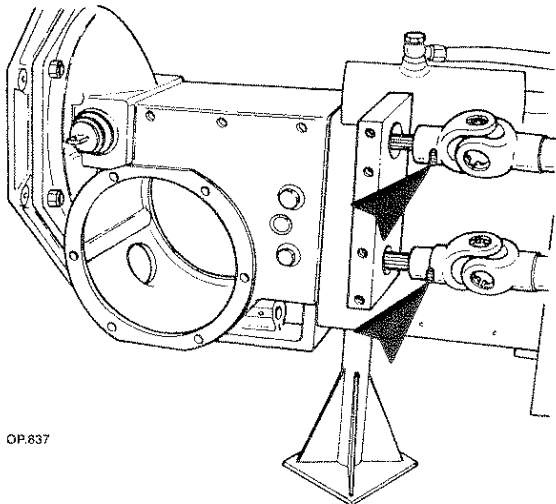

OP.837

11 - Loosen the fastening dowels bolts of the central joints.

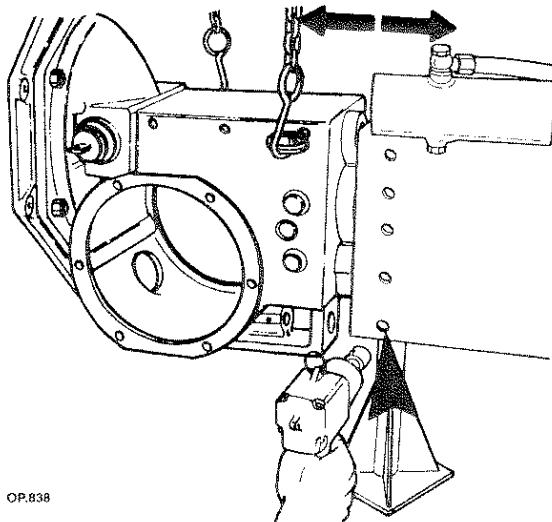

OP.838

12 - Loosen the fastening screws of the front unit to the central body and remove the rear transmission box for the Superpark.



WARNING - DANGER



Perform operations by strictly observing accident prevention regulations.

- Do not use gasoline, diesel oil or other flammable liquids to degrease or clean parts but use commercial non-toxic solvents instead.

Keep environment clean. Dispose of waste fluids, used filter cartridges, oils, lubricants and grease cleaners in the most suitable way and in compliance with regulations in force.

The collection of waste oils must be performed by authorized plants.

Connecting

A Tigretac - B Superpark

Proceed to the connection of the front transmission, bearing in mind the following instructions:

a - Proceed inversely as to the disconnection steps A - B.

b - Observe the driving torques listed at page 4.

c - Clean all parts to be mated carefully.

d - Apply a 3 mm string of gasket forming compound following the path indicated in the figure.

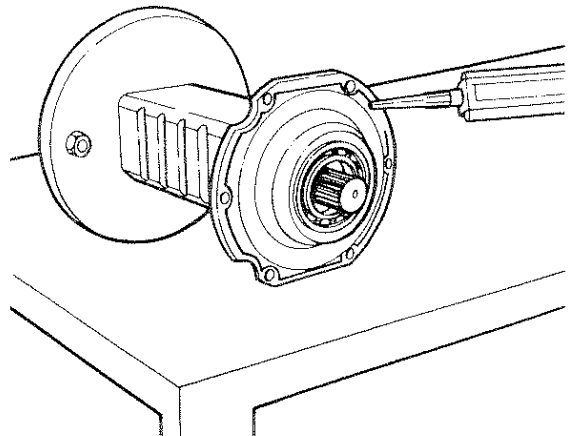

OP.839

- application of gasket forming compound

e - mount the dowels fastening the universal joints with Loctite 242 (average strong thread lock).



Disassembly - Assembly

Front transmission for the Tigretac and rear transmission of the Superpark

For the dismantling of the different components from the transmission box, proceed as follows:

1 - Clamp the box onto a horse or place it over a work bench.

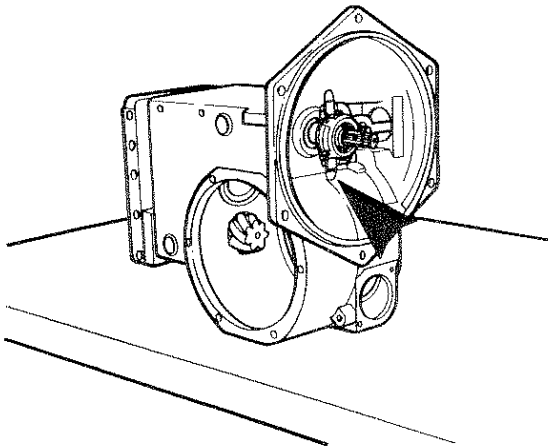

OP.840

2 - Remove the retainer clip and remove the clutch disengagement bearing.

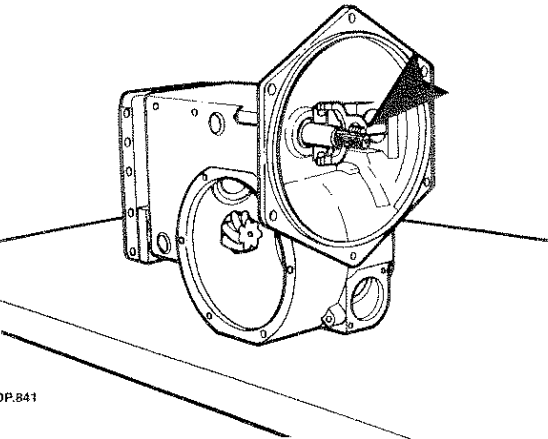

OP.841

3 - Loosen the screw and remove the clutch lever.

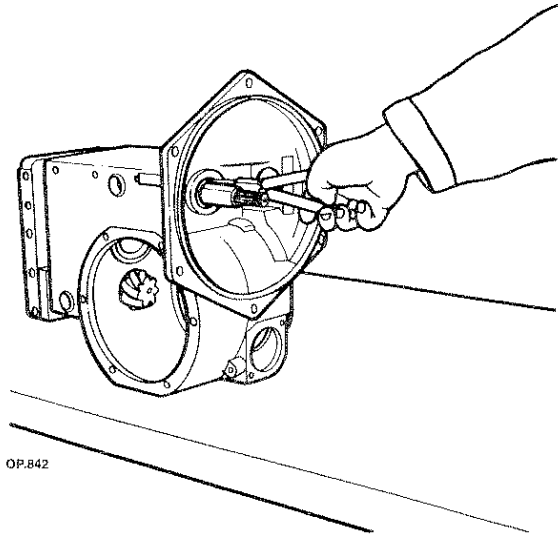

OP.842

4 - Remove the retainer ring and remove the clutch thrust bearing guide.

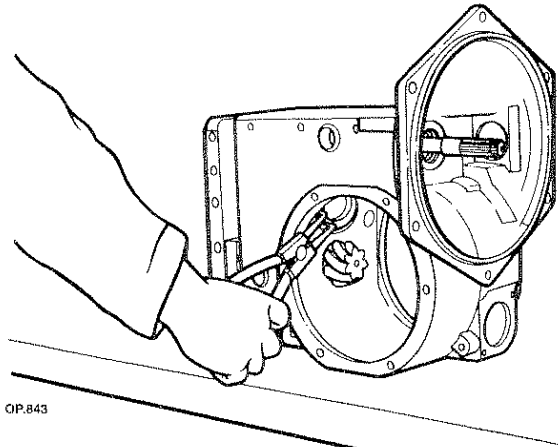

OP.843

5 - Remove the central articulation flange retainer spring ring.

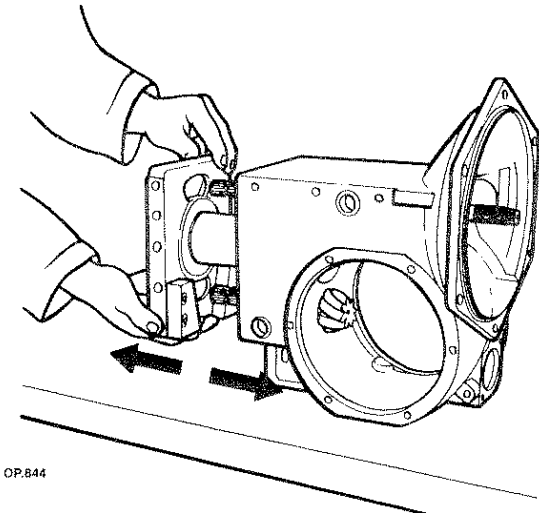

OP.844

6 - Remove the central articulation flange.

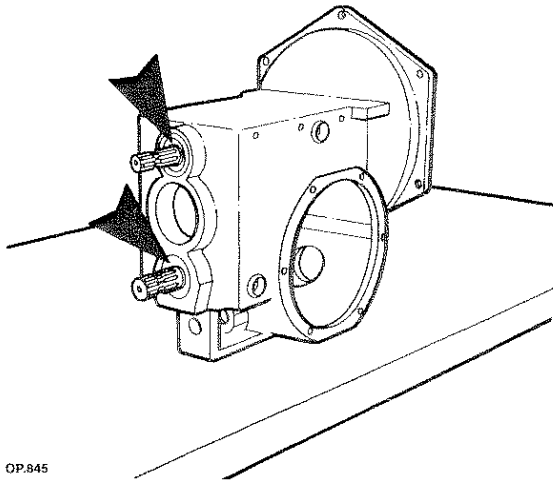

OP.845

7 - Remove the main shaft and pinion seal rings.

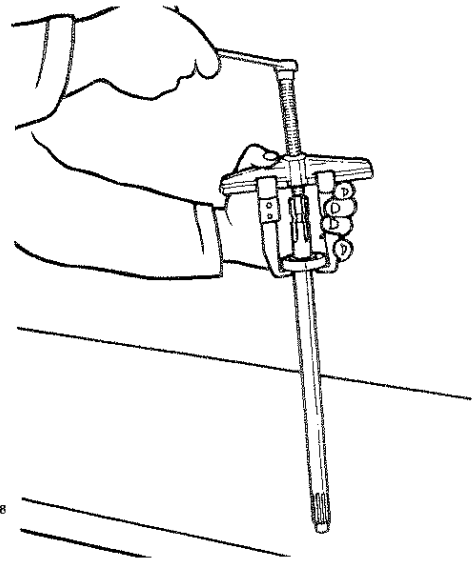

OP.848

10 - Remove the bearing using the universal puller AT 37981257.

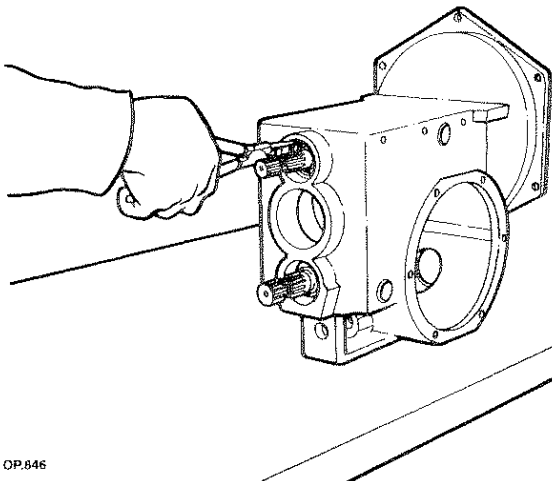

OP.846

8 - Remove the main shaft retainer ring.

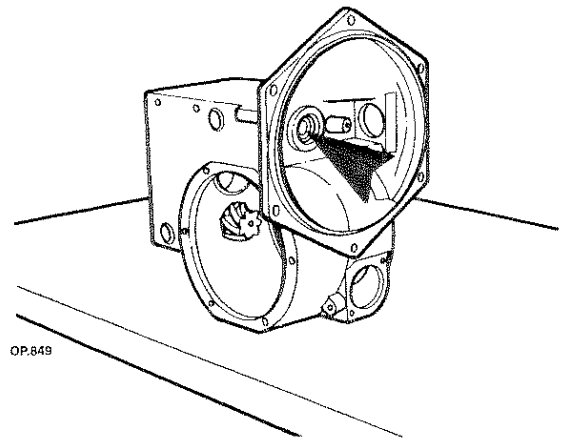

OP.849

11 - Remove the main shaft seal ring.

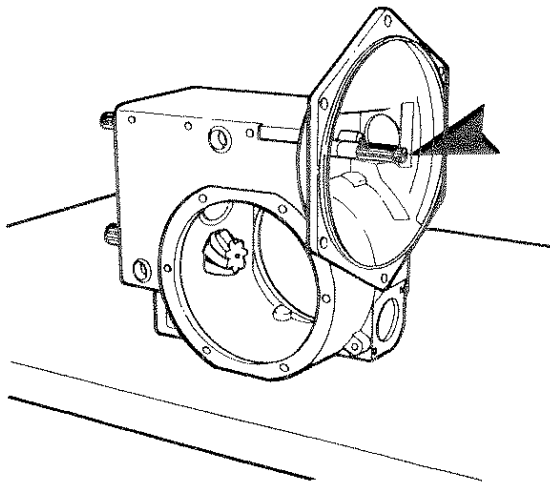

OP.847

9 - Remove the main shaft with the help of a hammer.

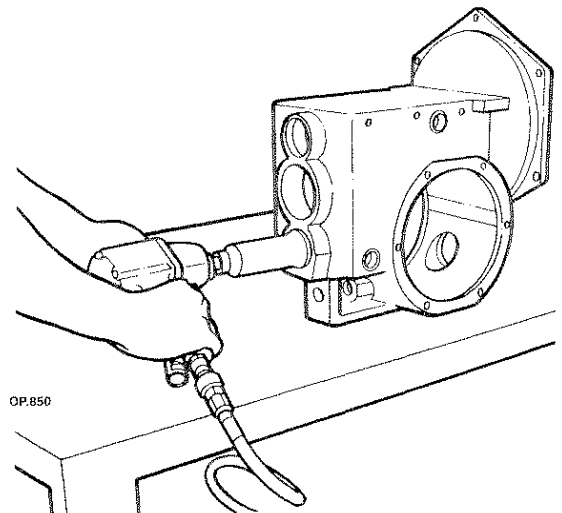

OP.850

12 - Loosen the pinion bearing fastening ring nut with tool AT 37981306.

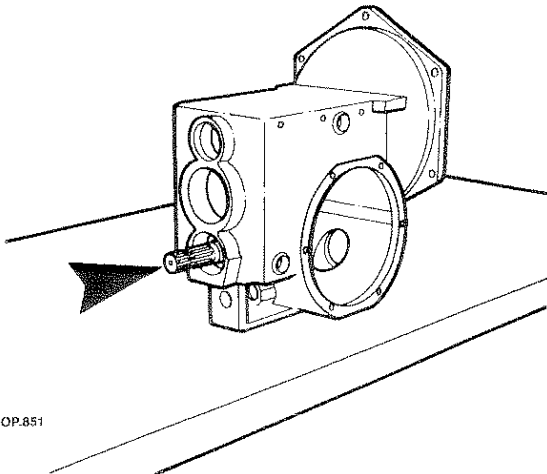

OP.851

13 - Remove the pinion along with the inner housing of the pinion rear bearing.

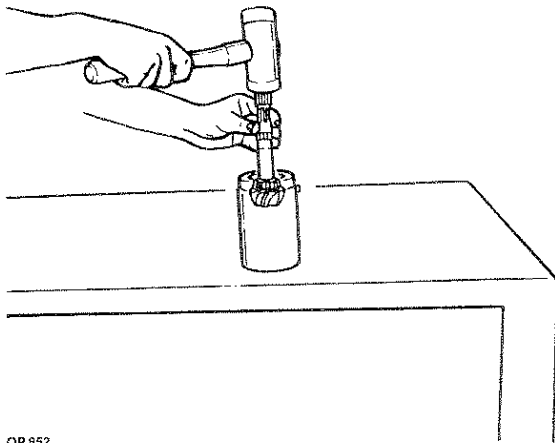

OP.852

14 - Remove the bearing on the pinion with tool AT 37981314.

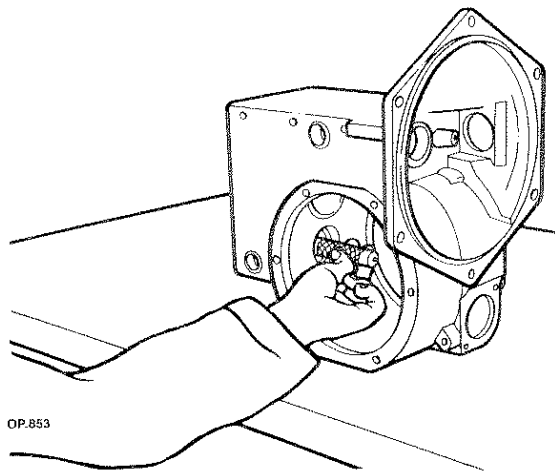

OP.853

15 - Remove the housing of the bearings on the gearbox with the help of the driver AT 37981278 along with pinion bearing shims.

16 - Make sure not to invert the pinion bearings since the pinion adjustment thickness also depends on the bearing.



WARNING - DANGER



Perform operations by strictly observing accident prevention regulations.

- Do not use gasoline, diesel oil or other flammable liquids to degrease or clean parts but use commercial non-toxic solvents instead.

ASSEMBLY

Proceed to the assembly, bearing in mind the following instructions:

- a - clean guard carefully, especially the inside.
- b - oil and grease the O-ring and the seal rings.
- c - proceed inversely as to the dismantling.
- d - follow the pictures on page 14 for location of the different components.
- e - observe the driving torque listed at page 4.
- f - consider the following operations.

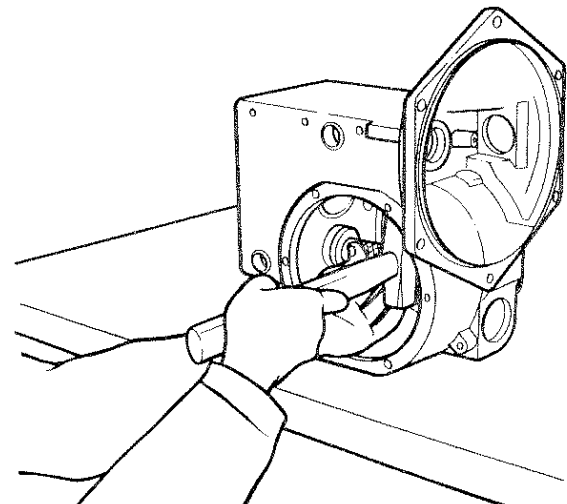

OP.854

1 - Mount the housing of the pinion bearings with the help of tool AT 37981277.

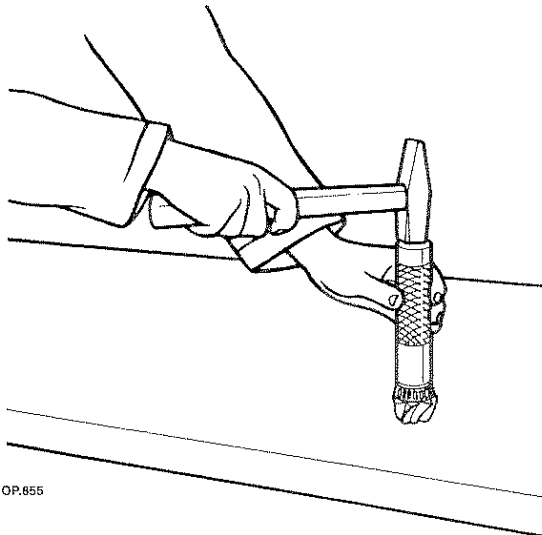

OP.855

2 - Mount the bearings on the pinion with the help of tool AT 37981271.

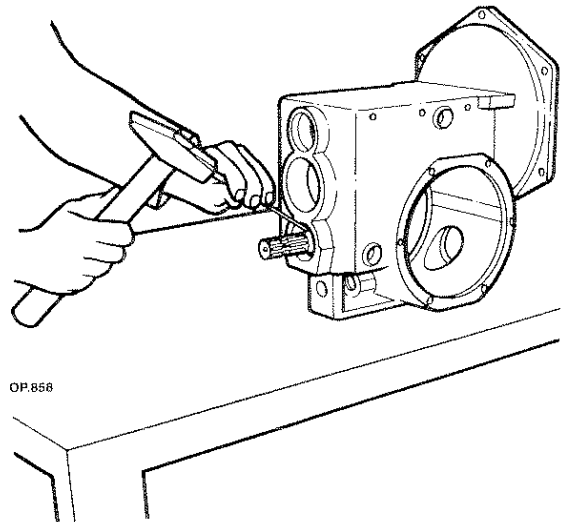

OP.858

5 - Dent the ring nut carefully.

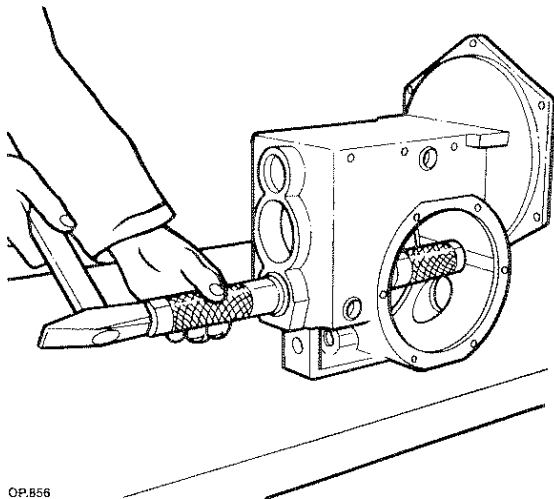

OP.856

3 - Insert the pinion on the box, position tool AT 27981273 and install the rear bearing with tool AT 37981271.

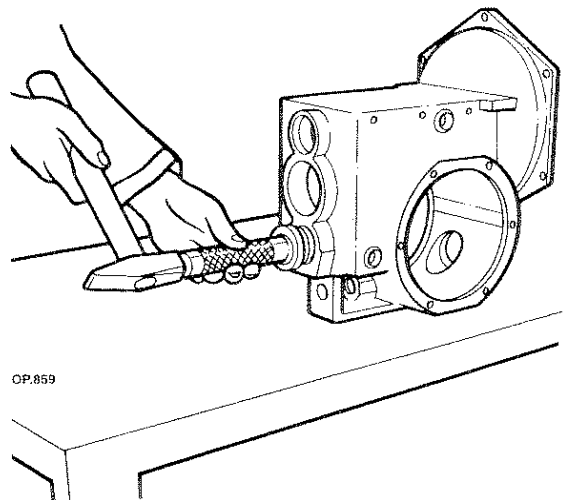

OP.859

6 - Mount the seal ring with bushing AT 37981021 and planer AT 37981275.

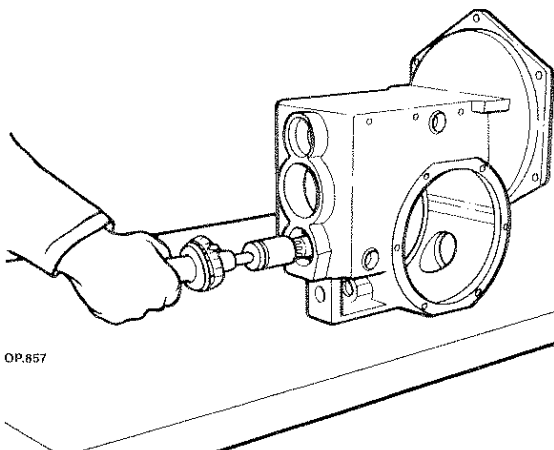

OP.857

4 - Fasten the ring nut with tool AT 37981306 until you achieve a rotating torque of the pinion of 250 - 300 Ncm with torquemeter AT 37981196 and adapter AT 37981281.

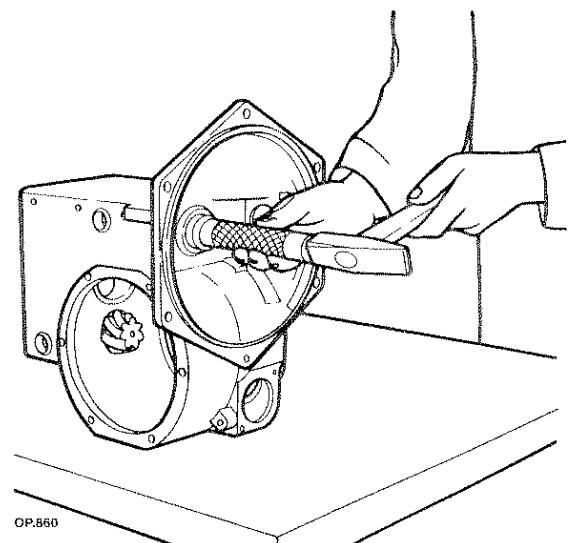

OP.860

7 - Mount the seal ring of the main shaft with planer AT 37981279.

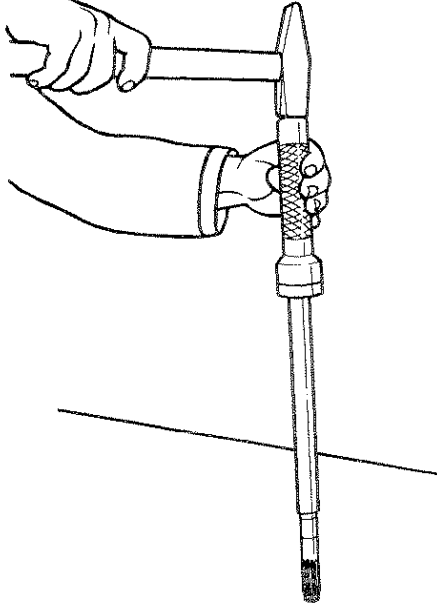

OP.861

8 - Mount the bearing on the main shaft with driver AT 37981276.

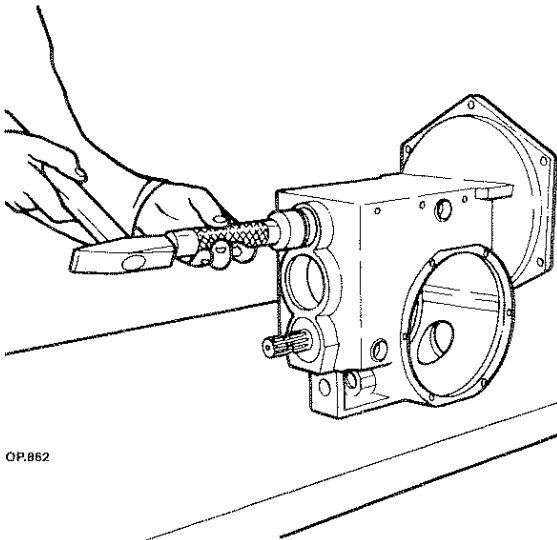

OP.862

9 - Mount the main shaft with tool AT 37981276.

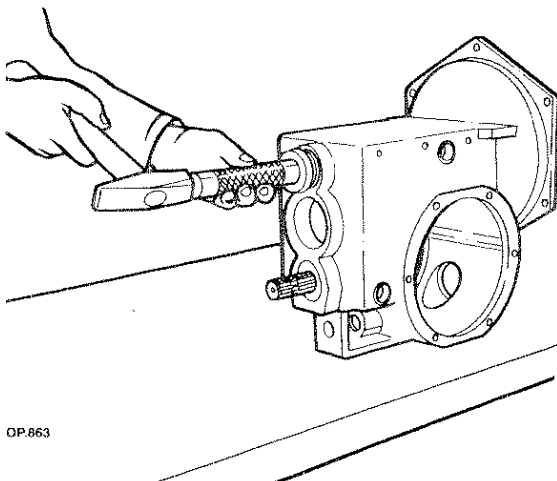

OP.863

10 - Mount the seal ring using driver AT 37981274 and adapter AT 37981020.

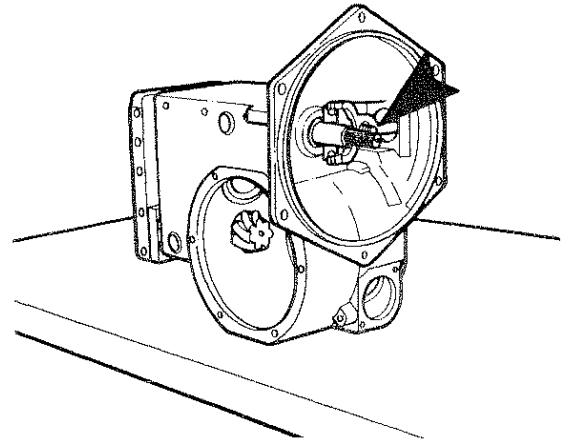

OP.841

11 - Before inserting the thrust bearing, grease the sleeve where the bearing and the splined shaft slide.



WARNING - DANGER



Perform operations by strictly observing accident prevention regulations.

- Wear safety clothing such as, gloves and safety shoes.
- Do not align slots with hands but use specific tools instead.



DIFFERENTIAL UNIT ASSEMBLY

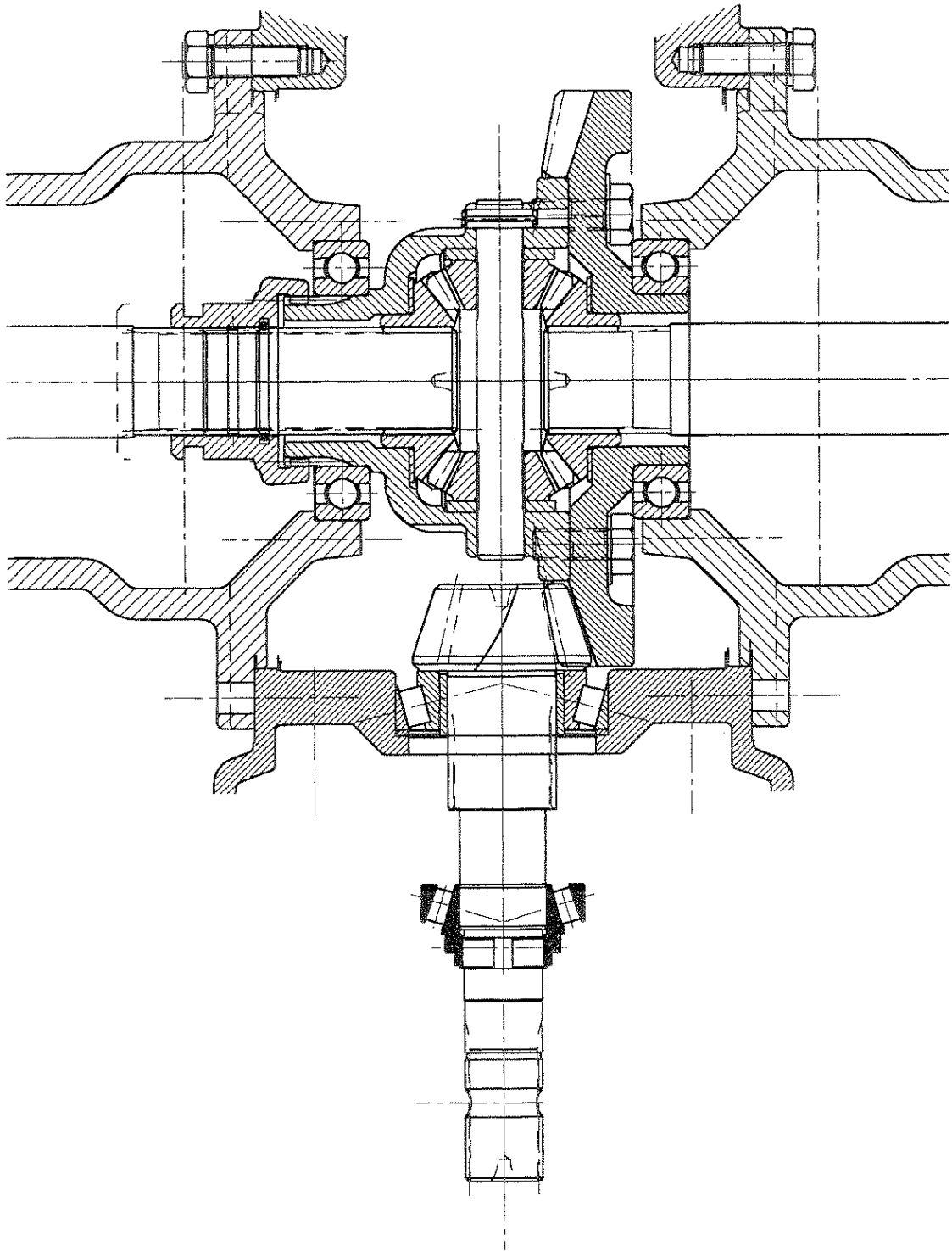



DIFFERENTIAL UNIT

Adjustment of the crown wheel and pinion.

A - Calculation of the thickness of the support ring of the bevel pinion bearing.

The value of said thickness is determined by measuring the height of the pinion head on tool AT 37981282; insert the pinion on the tool AT 37981282 with the bearings, turn ring nut slightly in order to create a revolving momentum.

Use a dial gauge, place the rod (feeler pin)

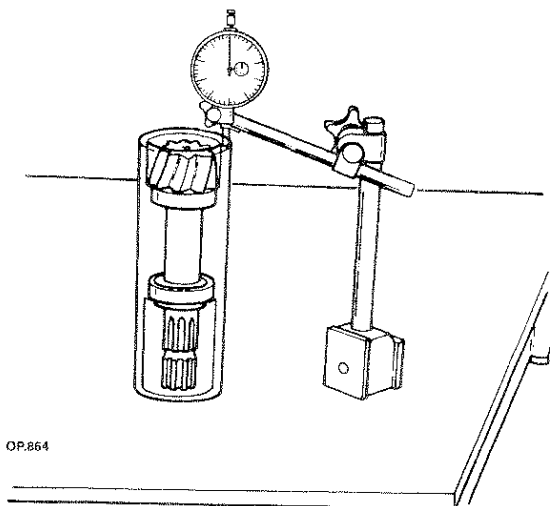

on a tool and zero set it then place it on the pinion head. The value read must be sub-

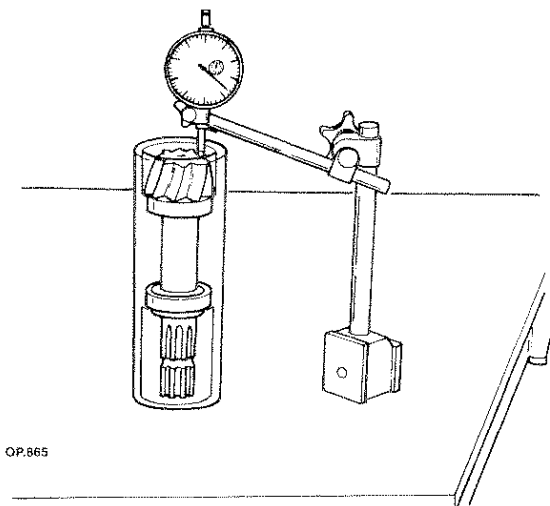

tracted from the centesimal value written with an engraver on the head of the pinion.

If (A) is the value measured by the dial gauge and (B) is the one printed by the manufacturer on the pinion, the thickness (S) of the support ring to be mounted is given by the following equation:

$$S = A - (+B) = A - B$$

$$S = A - (\pm B) =$$

$$S = A - (-B) = A + B$$

Example:

A = 2.70 (value read on dial gauge)

B = -0.15 (centesimal dimensions marked on the pinion by the manufacturer)

$$\text{thickness } S = A - (+/-B)$$

$$= 2.70 - (-0.15)$$

$$= 2.70 + 0.15$$

$$= 2.85$$

In this case a 1.85 mm thick ring must be mounted (underneath the pinion bearing).

If necessary round off to the highest figure within 0.05 mm.

Therefore the shim to be mounted is 1.9 mm thick.

Note:

The support ring of the roller bearing on the pinion is supplied as spare part:

mm 1.7 - 1.8 - 1.9 - 2 - 2.1 - 2.2 - 2.3.



B. Pinion bearing preloading

To perform the preloading of the bevel roller bearing of the pinion proceed as follows:

- 1 - Tighten the ring nut with a driving torque of 8 - 10 Kgm (78-98 Nm).
- 2 - Rotate the pinion a few turns so that the bearings are properly positioned in their seat.

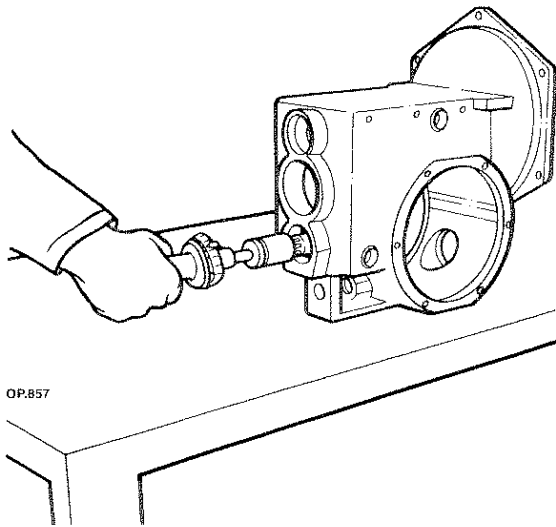

OP.857

- 3 - Loosen the ring nut and tighten it again with the tool AT 37981306 until you reach a rotating resistance of the pinion equal to 250 - 300 Ncm (0,25 - 0.3 Kgm) with torquemeter AT 37981196 and adapter AT37981281.

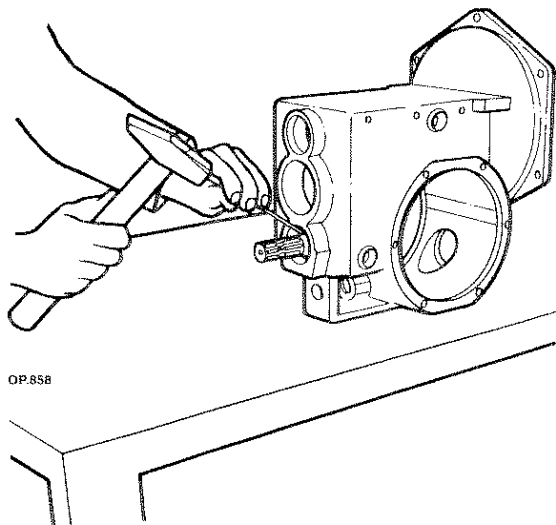

OP.858

Dent the ring nut.

C) Adjustment of backlash between the ring gear and the pinion and preloading of the differential box bearings

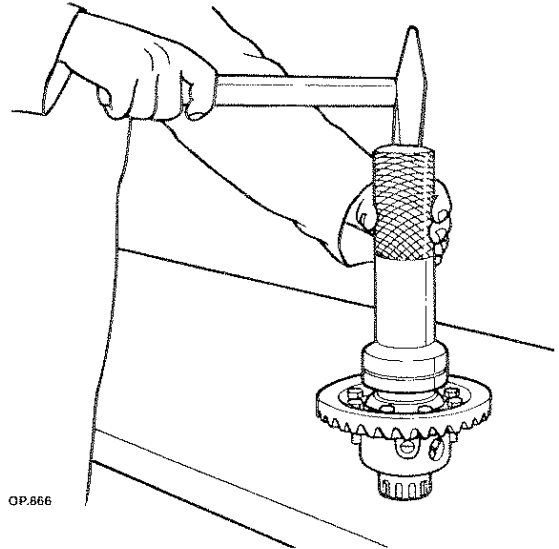

OP.866

- 1 - Mount the bearing on the differential box using the driver AT 37981093

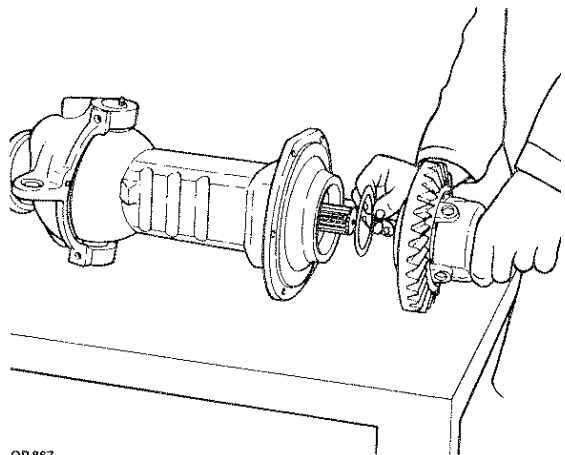

OP.867

- 2 - Insert between the differential support and the unit a rated thickness (PS 0.2 mm).
- 3 - Insert the differential unit on the support with the help of a hammer (plastic or copper).
- 4 - Mount the differential unit in the transmission box without applying any sealing agent nor fastening it with the screws.



5 - Apply on the side opposite the transmission box the tool AT necessary to align the differential unit with the box and slightly preload the differential bearing.

6 - Apply a centesimal dial gauge with magnetic base over the transmission box, with rod placed as perpendicularly as possible and resting on the edge of a tooth of the ring gear.

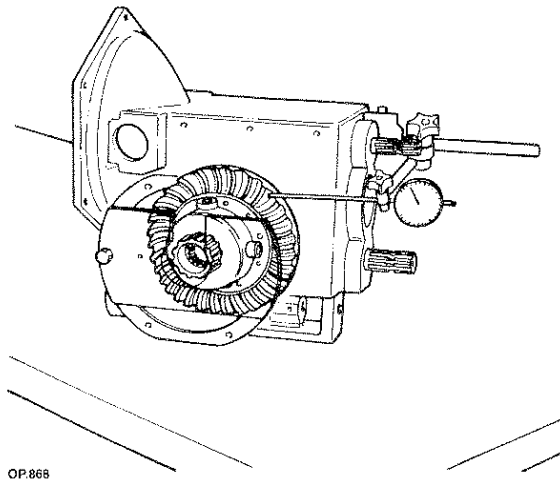

7 - Check the backlash by offsetting it by 120° and comparing the average of the three values with the normally set play (0.15 - 0.23).

8 - If the value measured is higher or lower than the set value, it is then necessary to increase or decrease the value of the rated thickness (PS 0.2).

Note:

Adding a thickness (PS) of 0.1 mm the play between the teeth of the ring gear and pinion is reduced 0.07 mm, whereas by removing a thickness of 0.1 mm the play increases 0.07 mm. The thickness PS is supplied with spares: 0.1 - 0.2 - 0.3 - 0.5 mm.

9 - Remove the differential support and mount the calculated thickness.

10 - Mount the differential support assembly onto the transmission box after having cleaned and degreased the surfaces to be mated and having applied a 3 mm string of gasket forming compound following the path indicated in the figure.

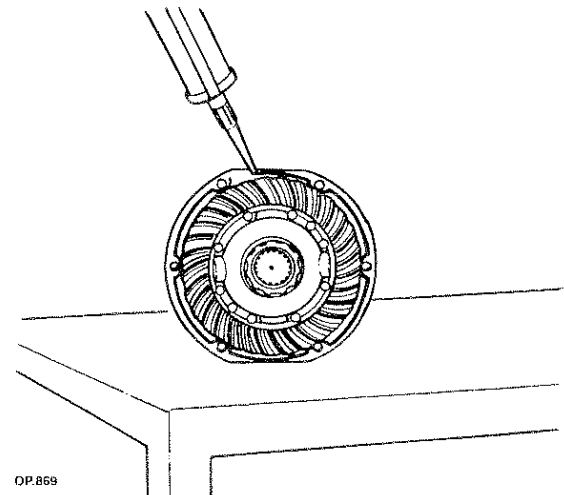

- diagram showing application of gasket forming compound.

11 - Observe the driving torque listed at page 4.

12 - Check the backlash between the ring gear and pinion with normal set play of 0.15 - 0.23 mm.

D) Differential box bearing preloading

13 - Position the centesimal dial gauge with support AT 27981215 on the mating surface between the support and the box, so that the feeler pin is directly on the seat of the bearing on the differential box and zero-set the dial gauge.

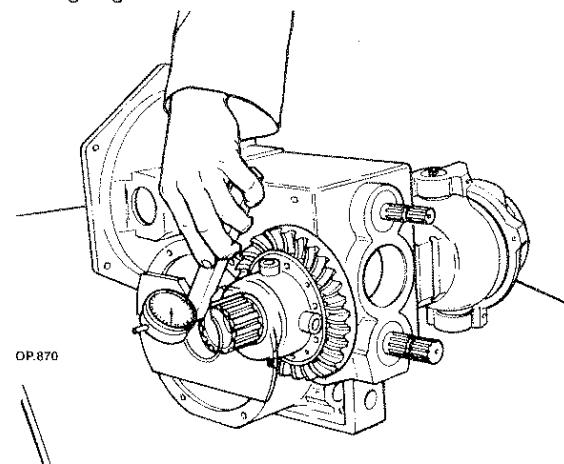

Now position the gauge directly on the bearing of the differential box support so that the feeler pin is in contact with the mating surface of the box.

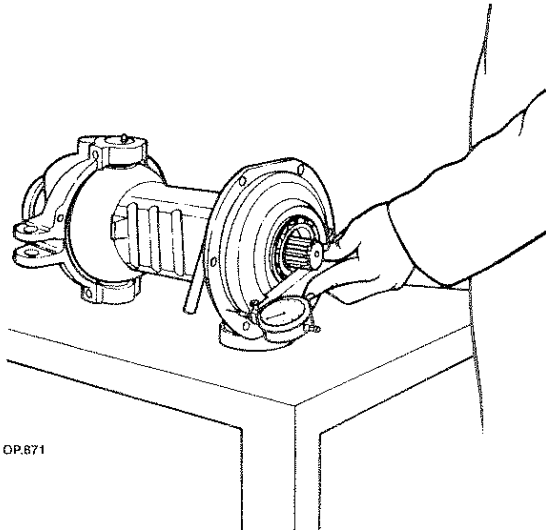

OP.871

14 - Perform measurement by offsetting it by 120° and the average of the three values Gm added to a preload of 0.1 mm will give you the thickness S to be mounted between the differential box and the bearing of the differential support.
If necessary round off to the highest figure within 0.05 mm.

Example:

Gm = 0.25 average of values read on dial gauge

0.1 mm = major value to increase the preloading of the bearings.

$$\begin{aligned} \text{Thickness } S &= Gm + 0.1 \\ &= 0.25 + 0.1 \\ &= 0.35 \end{aligned}$$

round off to the highest figure 0.05 mm.

In this case you need to mount two 0.2 mm shims = 0.4 mm.



WARNING - DANGER



Perform operations by strictly observing accident prevention regulations.
Keep environment clean. Dispose of waste fluids, used filter cartridges, oils, lubricants and grease cleaners in the most suitable way and in compliance with regulations in force.

DIFFERENTIAL

Disassembly - Assembly

When unit is detached from the transmission box proceed as follows:

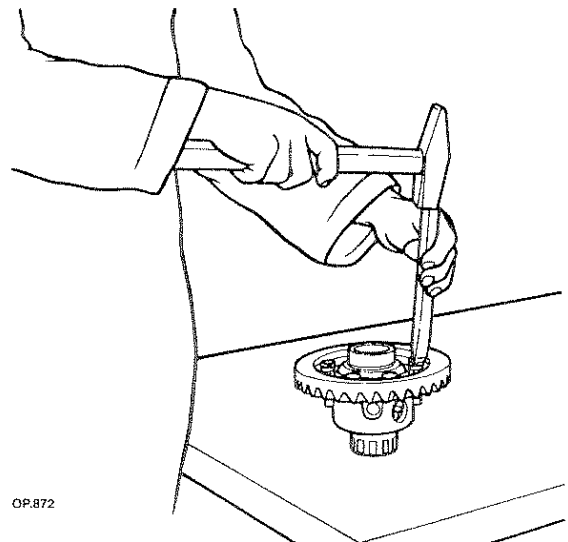

OP.872

1 - Straighten the screw stop plates.

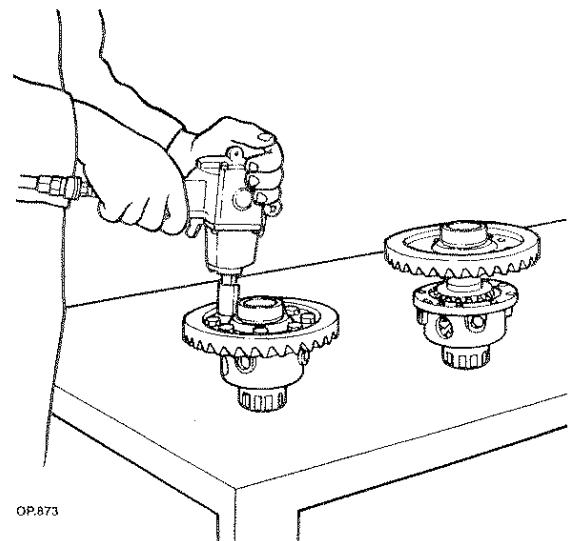

OP.873

2 - Loosen the screws fastening the bevel ring gear.

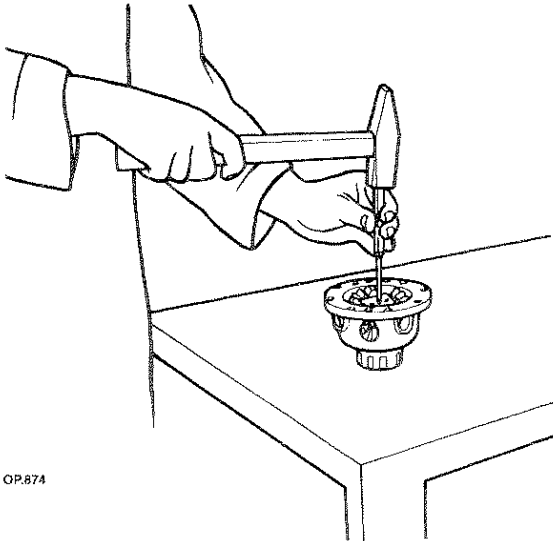

OP.874

3 - Remove the spring pins.

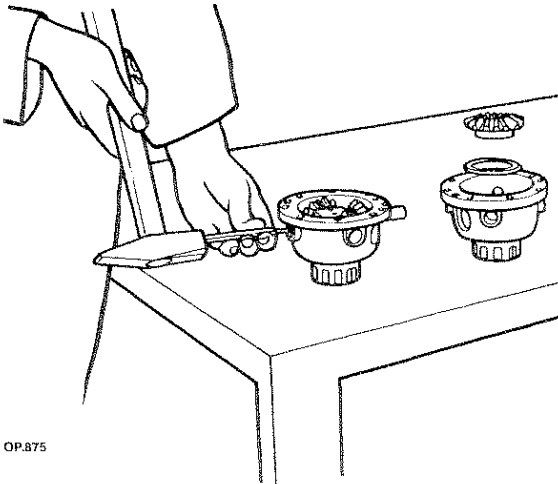

OP.875

4 - Remove the pins, along with the side pinions, the scraper fifth wheels and crown wheels.

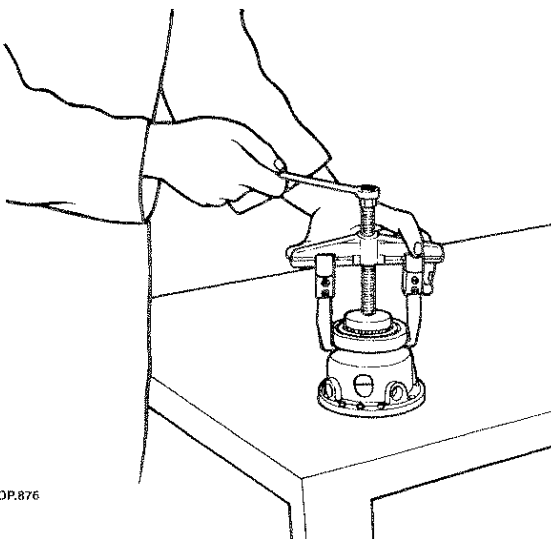

OP.876

5 - Remove the bearing with universal puller AT 37981247 and adapter AT 37981214.

ASSEMBLY

Proceed as follows:

a - proceed inversely as to the disassembly operations.

b - refer to drawings for location of different parts.

c - make sure that the groove of the spring pins is oriented towards the stress point so that spring is under strain.

d - tighten the screws with a driving torque of 8.5 Kg. (83 Nm).

e - check the axial play of the crown wheels.



WARNING - DANGER



Perform operations by strictly observing accident prevention regulations.

- When disposing oil follow environment control regulations.

Keep environment clean.

Checking the crown wheels axial play

To check the axial play of the crown wheels proceed as follows:

1 - Position the feeler pin of the centesimal dial gauge.

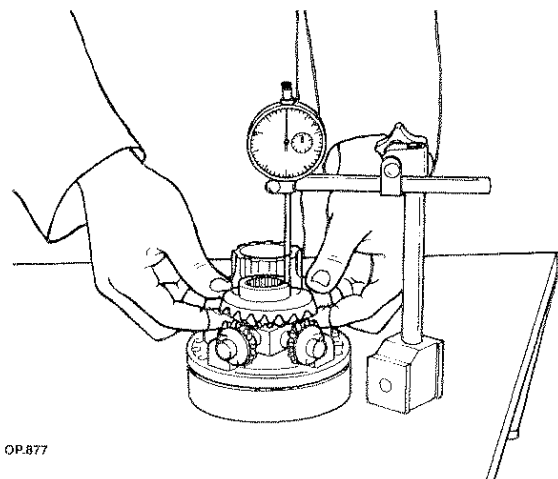

OP.877

2 - Move the crown wheel until it touches the side pinion and then push it against the differential box measuring on the centesimal dial gauge the axial play.

3 - The axial displacement for each crown wheel should be 0.15 - 0.30 mm.

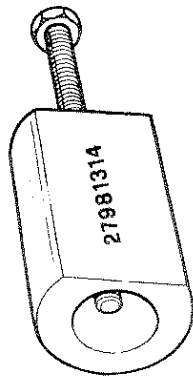

AT.191

1 - Steering cylinder pin extractor

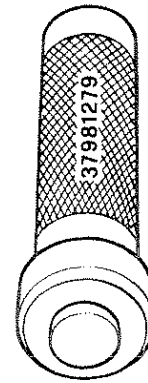

AT.192

4 - Drive for the assembly of the seal ring of the main shaft

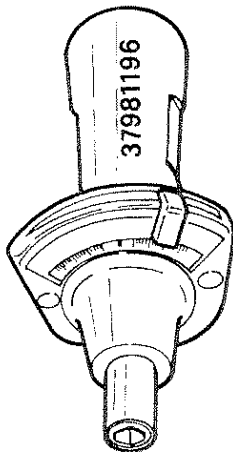

AT.020

2 - Torquemeter Ncm

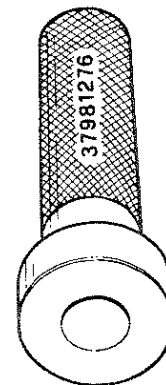

AT.193

5 - Driver for the assembly of the main shaft bearing

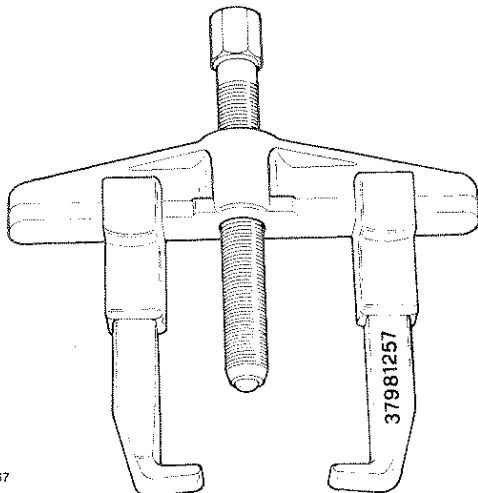

AT.067

3 - Universal puller

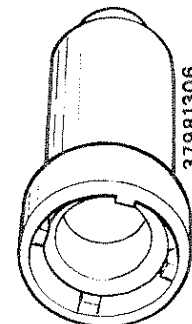

AT.194

6 - Key for the fastening of the differential pinion ring nut

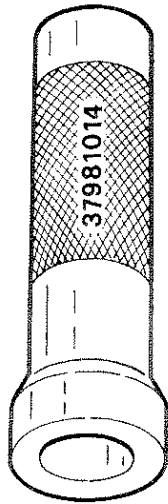

AT.023

7 - Driver for assembly of bearings

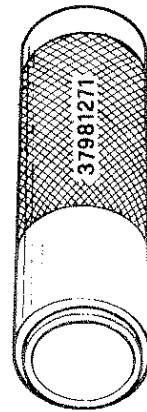

AT.198

10 - Driver for the assembly of the bearing of the differential pinion

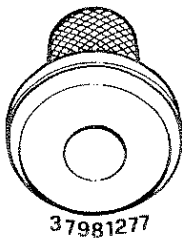

AT.196

8 - Driver for assembly of pinion bearing housing

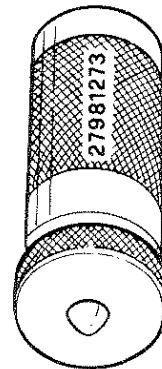

AT.199

11 - Tool for the mounting of the pinion rear bearing

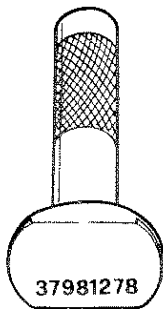

AT.197

9 - Driver for the disassembly of the pinion bearing housing.

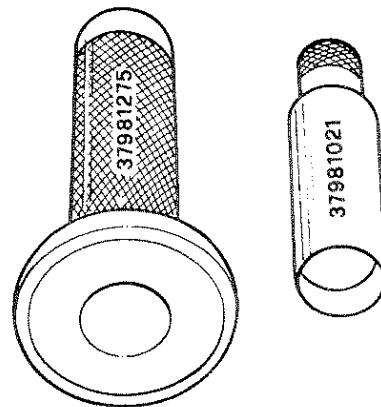

AT.200

12 - Driver and adapter for the mounting of the seal ring

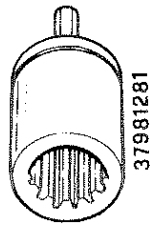

AT.201

13 - Key for the control of the pinion rotating torque

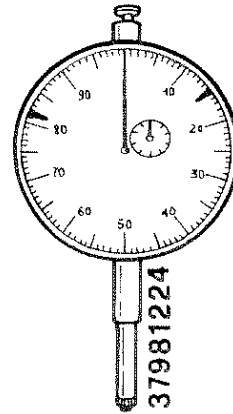

AT.026

16 - Centesimal dial gauge.

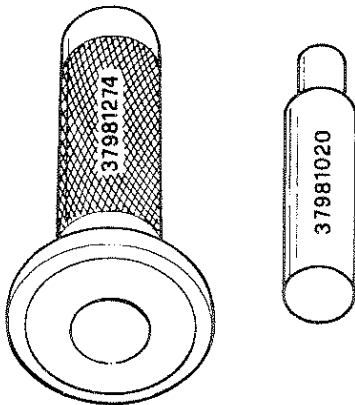

AT.202

14 - Driver and adapter for the mounting of the seal ring



AT.027

17 - Extension for centesimal dial gauge.

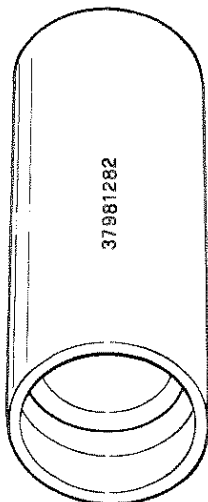

AT.203

15 - Tool to determine the thickness of the pinion bearing.

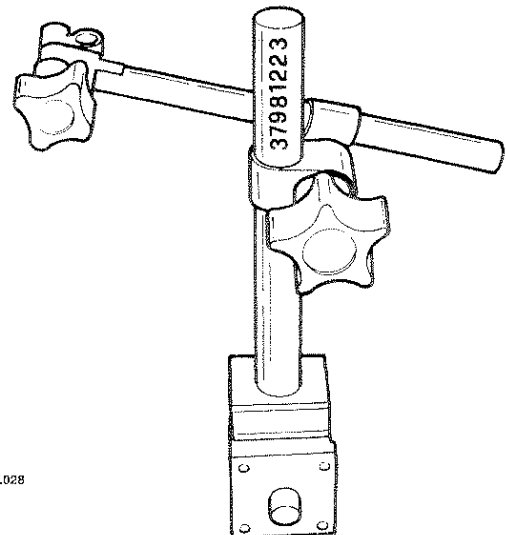

AT.028

18 - Magnetic support for centesimal dial gauge.

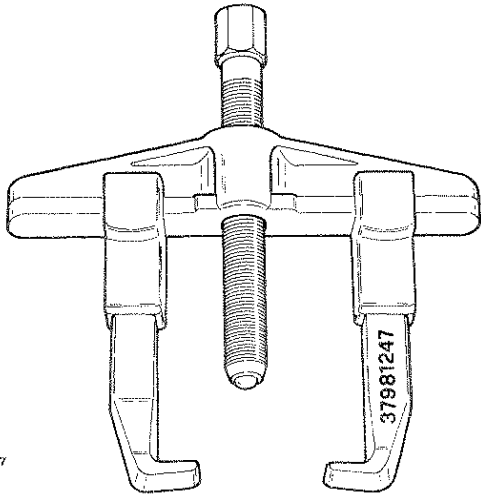

AT.007

19 - Universal puller.

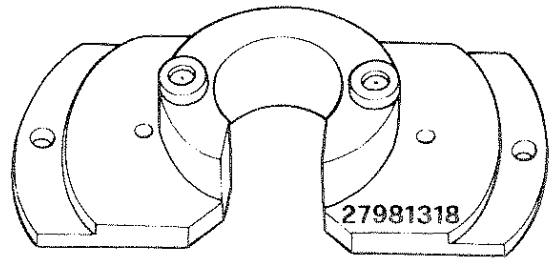

AT.204

22 - Tool for the alignment of the differential unit



AT.032

20 - Adapter to extract the differential box bearing.

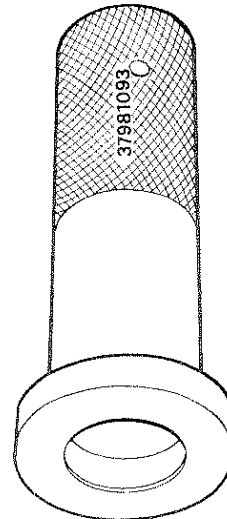

AT.045

23 - Driver for the assembly of the differential box bearing

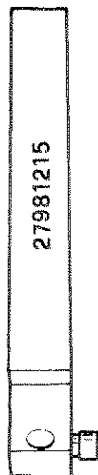

AT.031

21 - Dial gauge support

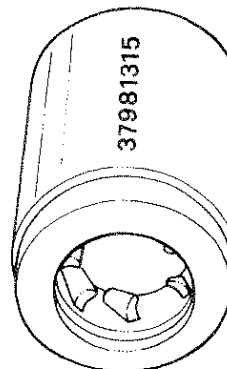

AT.195

24 - Driver for the removal of the pinion bearing



TIGRETRAC CENTRAL TRANSMISSION ASSEMBLY

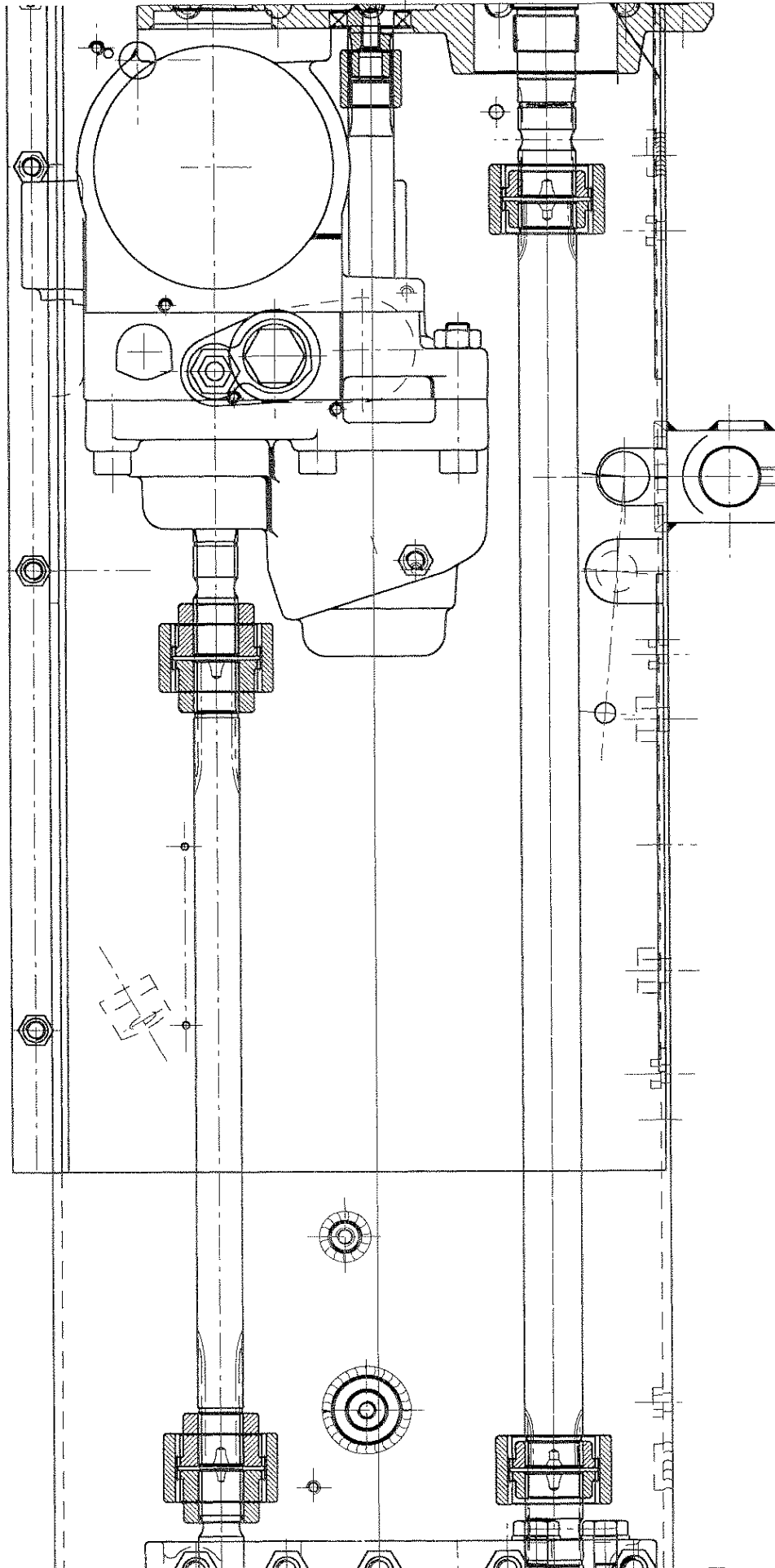



SUPERPARK CENTRAL TRANSMISSION ASSEMBLY

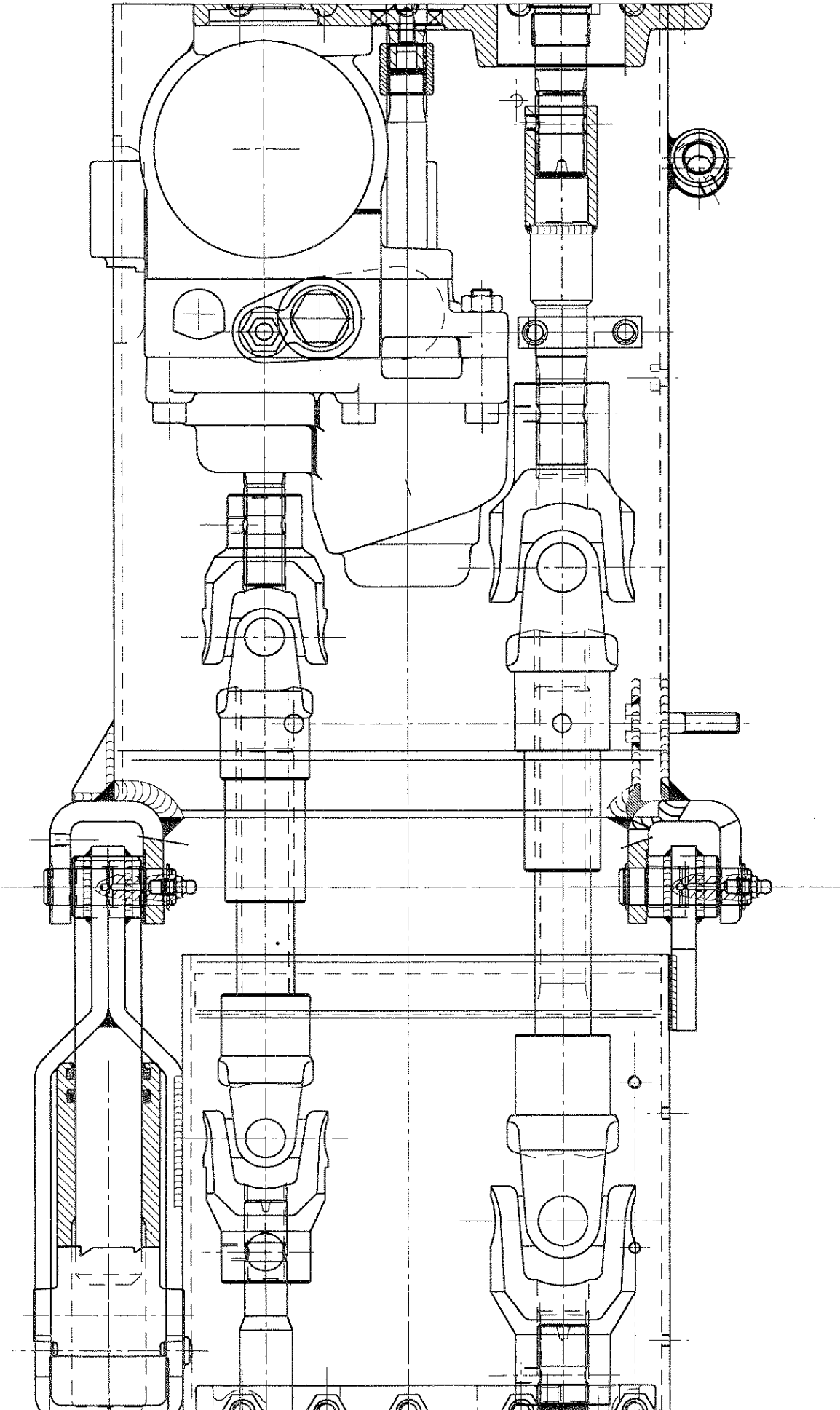



Central transmission - Hydrostatic unit

The hydrostatic unit features two bodies, one on top of the other, made up of:

1 - Pump with axial pistons with fixed engine power (max. 28 cm³) rotating unit with 9 pistons.

2 - Engine with axial pistons with fixed engine power (28 cm³) rotating unit with 9 pistons.

Inside the unit is housed the maximum level valve, the feed valves and the servocontrol for the variation of the pump.

Technical features

HYDROSTATIC UNIT	PUMP	ENGINE
Engine power	28 cm ³	28 cm ³
Engine power of boosting pump	9 cm ³	9 cm ³
Max. speed of non-stop rotation	3600 min ⁻¹	3600 min ⁻¹
Minimum rotation speed	500 min ⁻¹	500 min ⁻¹
Peak pressure	300 bar	300 bar
Boosting pressure	15-30 bar	15-30 bar
Oil continuous max. temperature	80 °C	80 °C
Recommended filtering	10 micron	10 micron

Instructions for disconnection and connection

Superpark

To have access to the hydrostatic unit you need to:

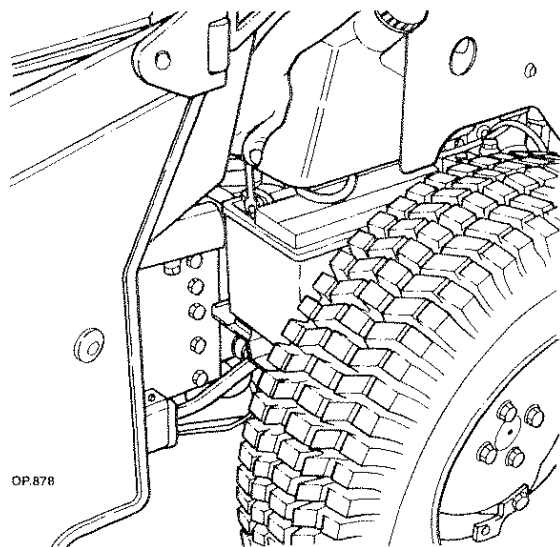

1 - Detach the positive wire of the battery and insulate it.

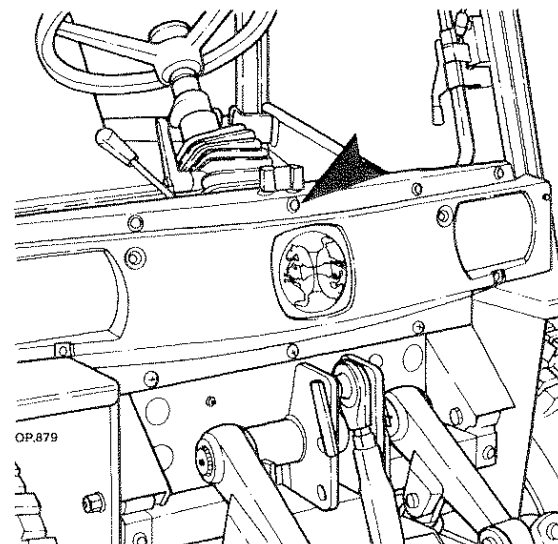

2 - Loosen the screws and remove the lights grille disconnecting the electric wires.

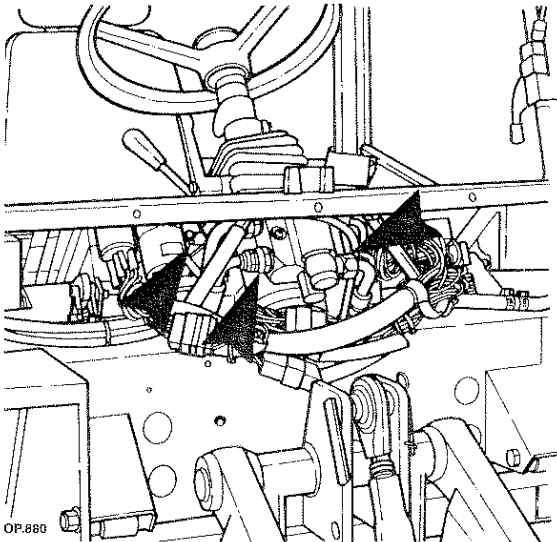

3 - Loosen the accelerator wire clamp and loosen the distributor delivery tubes and of the hydrodrive drain.

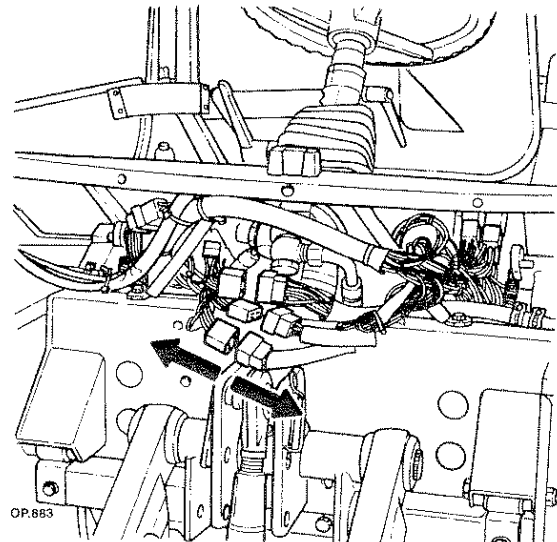

6 - Disconnect the rear electrical connections.

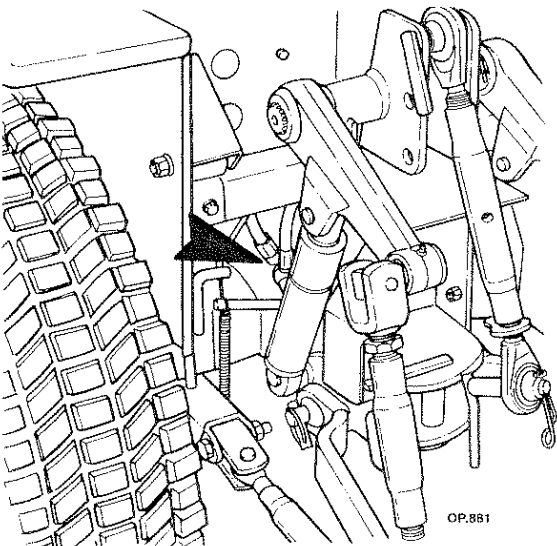

4 - Loosen the delivery cylinder tubes and plug holes with stoppers.

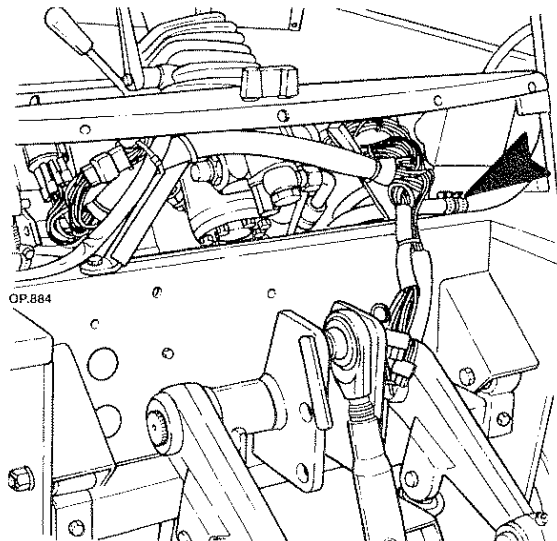

7 - Loosen the tube clamps and remove the cab heating tubes then plug holes with stoppers.

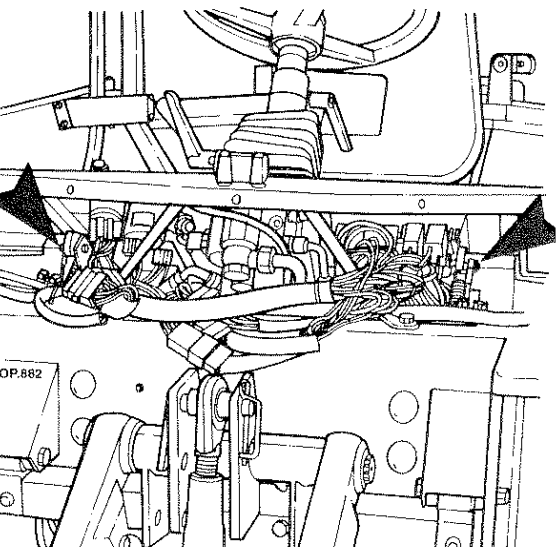

5 - Remove the seal rings and disconnect the service, emergency and parking brakes.

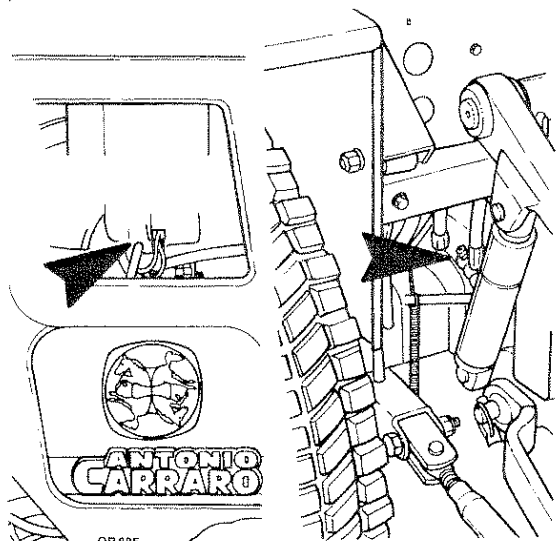

8 - Loosen the clamps locking the wires and traction disengagements then remove them partly - disconnect the windscreen pump tube.

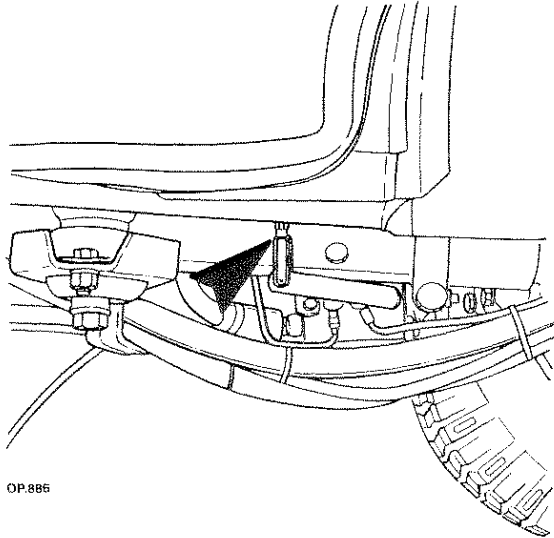

OP.885

9 - Remove the control fork (speedfix).

10 - Disconnect the Km counter connector and that of the gearbox oil filter warning light.



WARNING - DANGER



Perform operations by strictly observing accident prevention regulations.

- Use suitable hoisting means.
- Wear gloves to handle metal cords or chains.

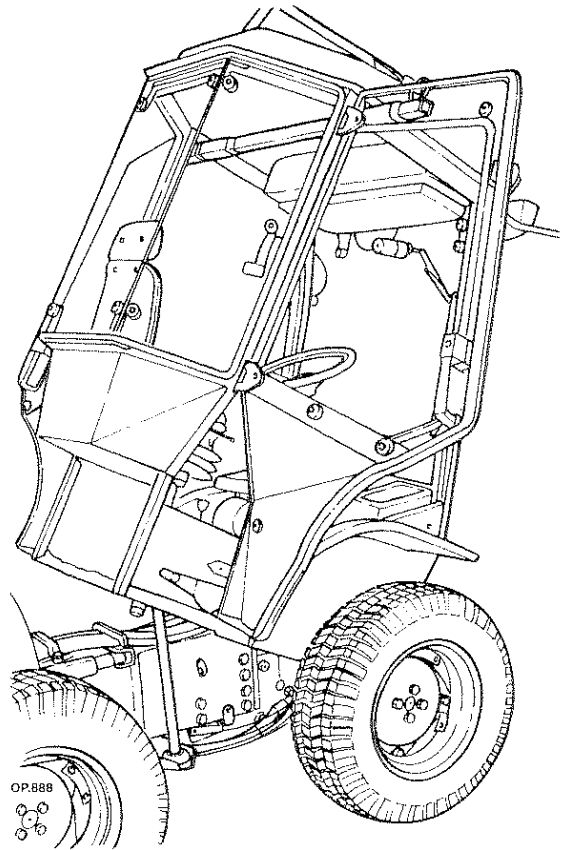

OP.888

12 - Sling the cab from the back with the help of a hoist and lift it so that you can place a safety screw down jack.

13 - Remove the stop rings and disconnect the PTO rod and forward gear.

14 - Remove the screw down jack and lower the cab.

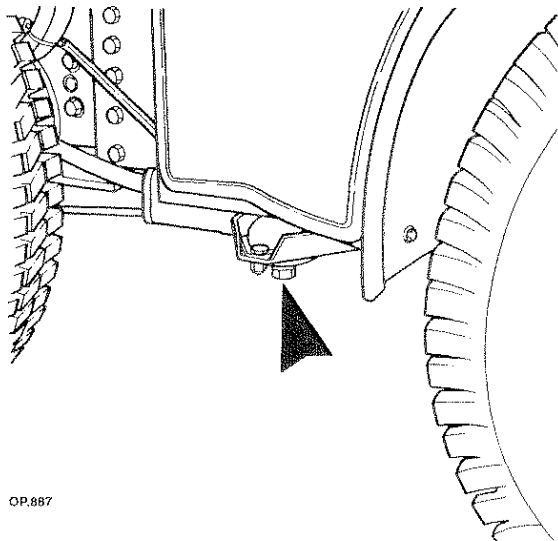

OP.887

11 - Loosen the silent block bolts of the cab rear.

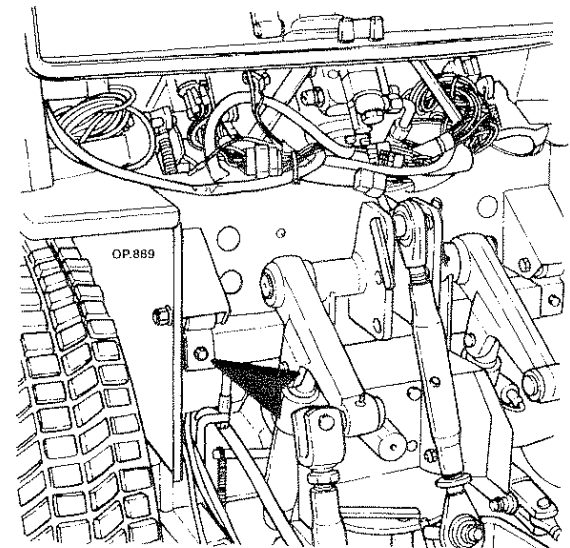

OP.889

15 - Loosen the bolts of the cab front supports.

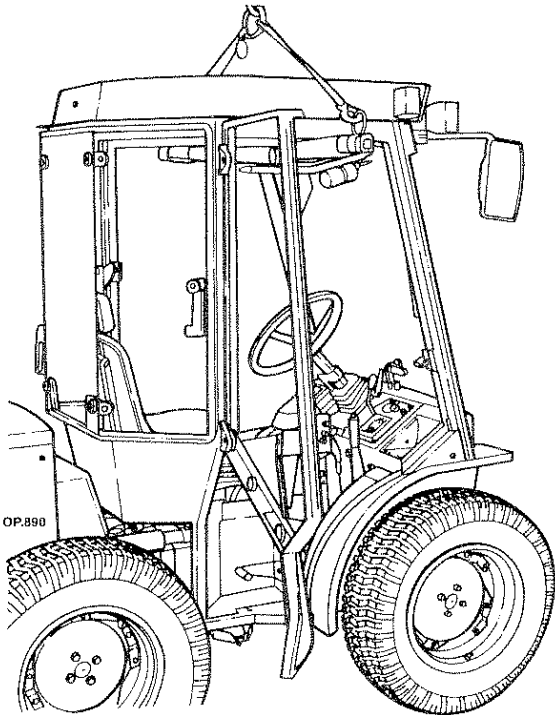

16 - Remove the cab completely.



WARNING - DANGER



Perform operations by strictly observing accident prevention regulations.

- Wear safety clothing such as gloves and safety shoes.

Watch out for shearing,
Watch out for squeezing,
Watch out for tangling.

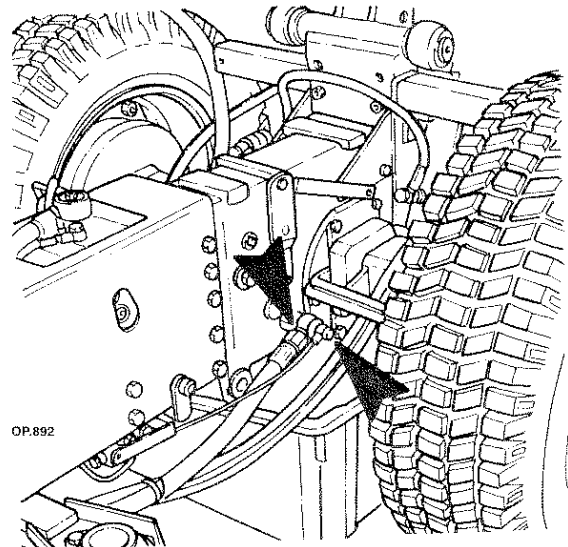

18 - Loosen the unions and drain oil into the special container.

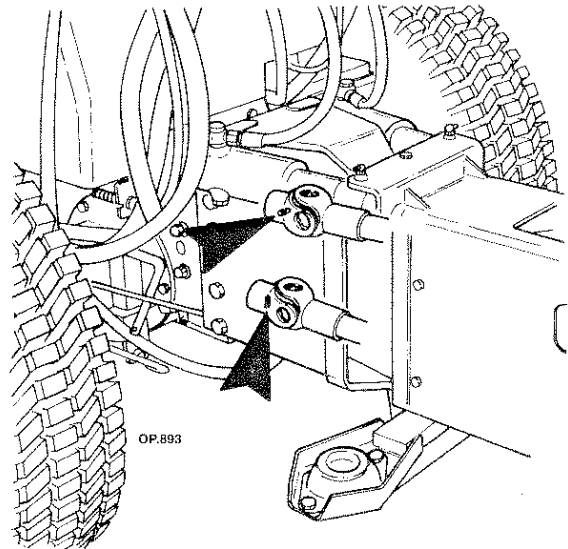

19 - Loosen the joint anchoring dowels and remove them.

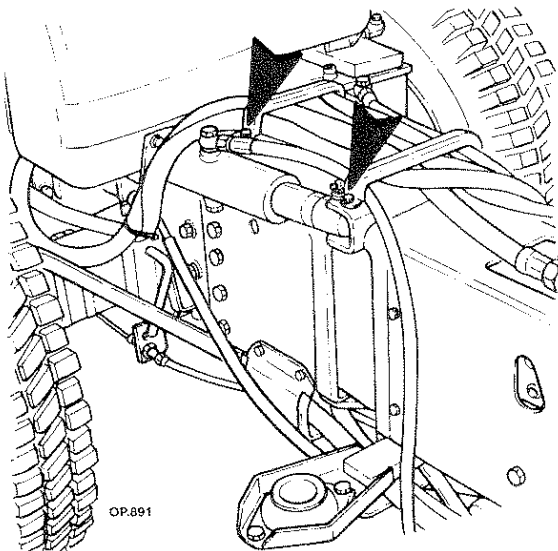

17 - Loosen the screws and remove the tube clamps.

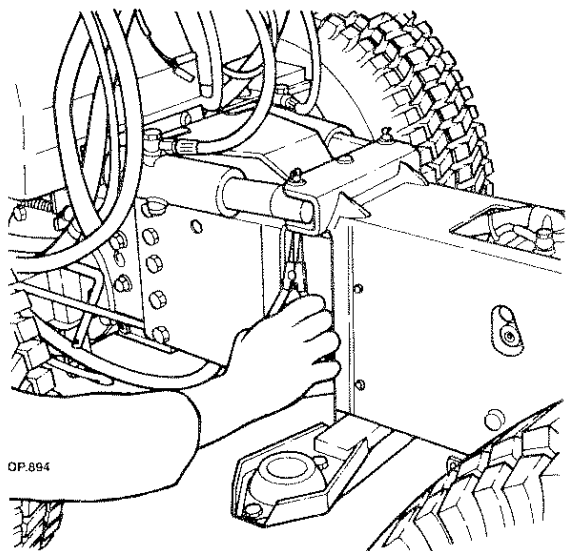

20 - Remove the spring rings on the hydro-drive cylinder pins.

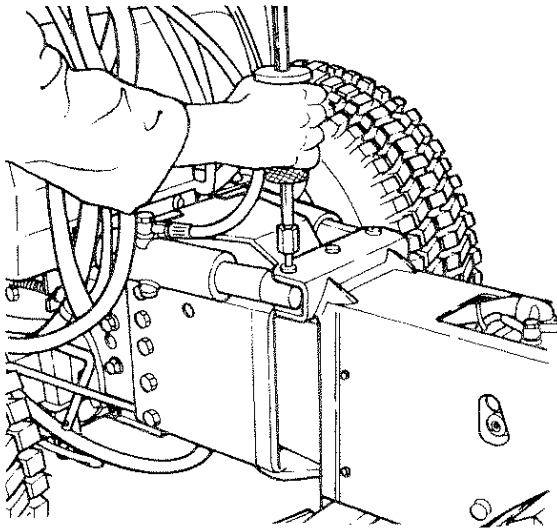

OP.895

21 - Replace the greaser with the adapter AT 27981047 and the puller AT 27981047 and remove the hydrodrive cylinder pins.

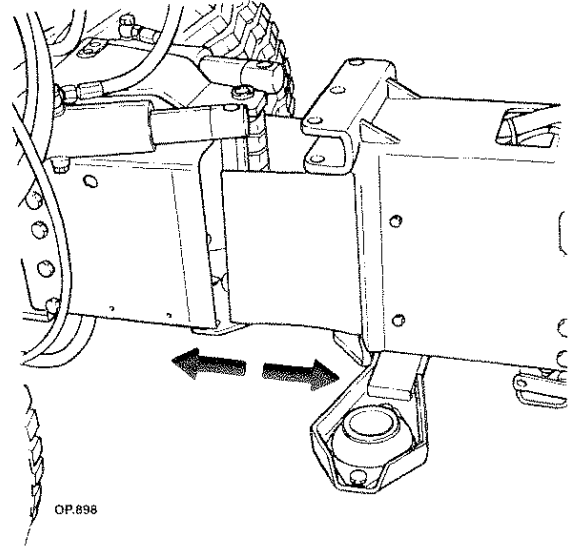

OP.896

24 - Separate the front forecarriage from the rear one.

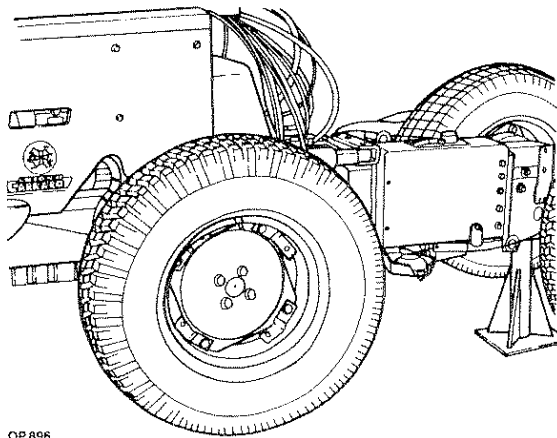

OP.896

22 - Place a mobile horse underneath the engine and a fixed one underneath the gear-box on the rear end.

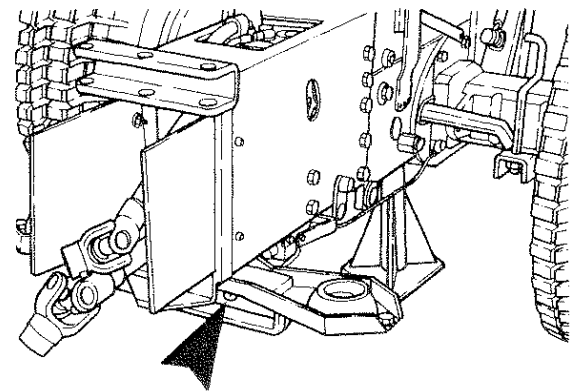

OP.899

25 - Loosen the screws and remove the cab support.

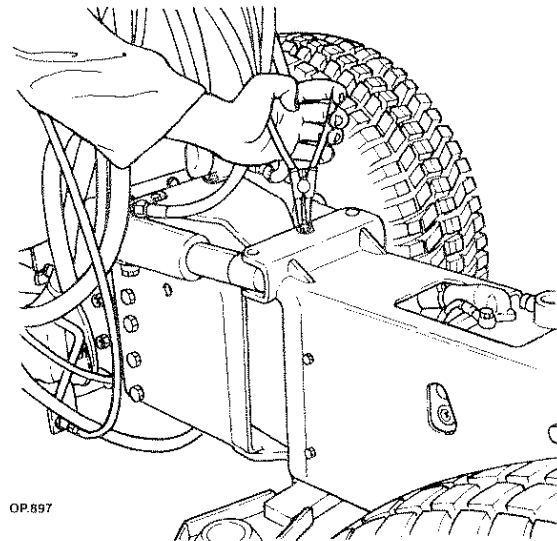

OP.897

23 - Remove the spring rings and with the help of a planer remove the central articulation pins.

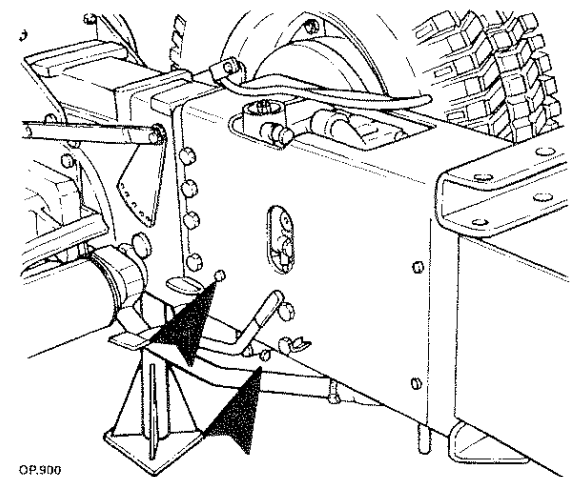

OP.900

26 - Loosen and remove the locking control.

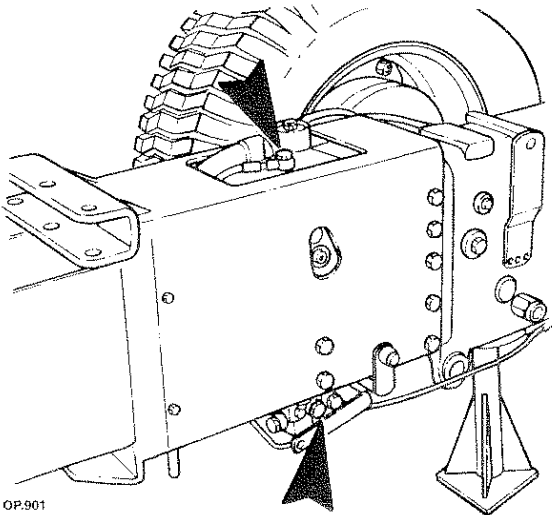

OP.901

27 - Loosen the unions of the joystick connection tube.

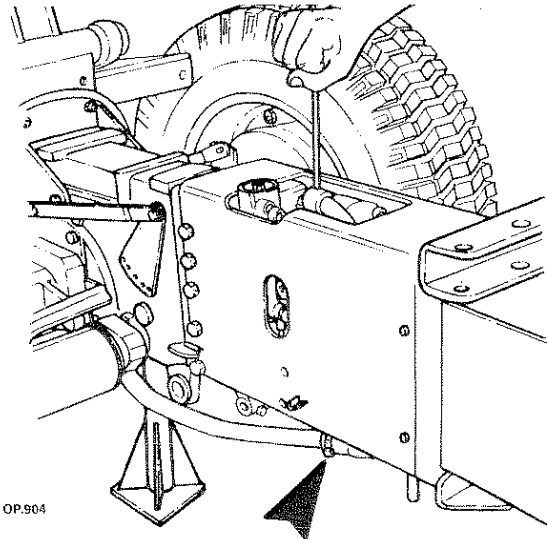

OP.904

30 - Loosen the tube clamps and remove the tube connecting the hydrostatic unit to the speed gear.

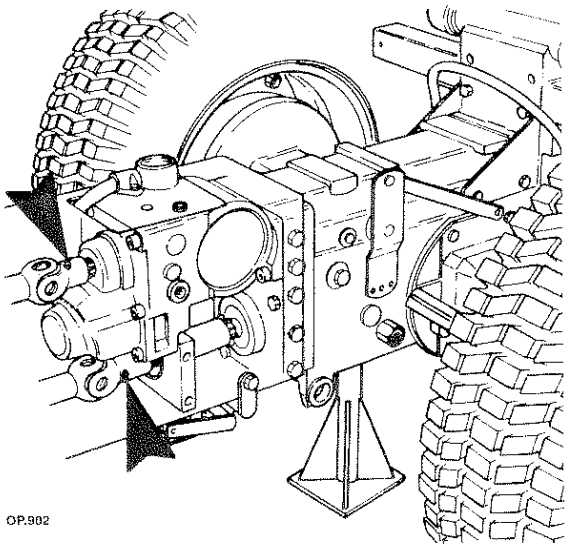

OP.902

28 - Loosen the joint anchoring dowels and remove them.

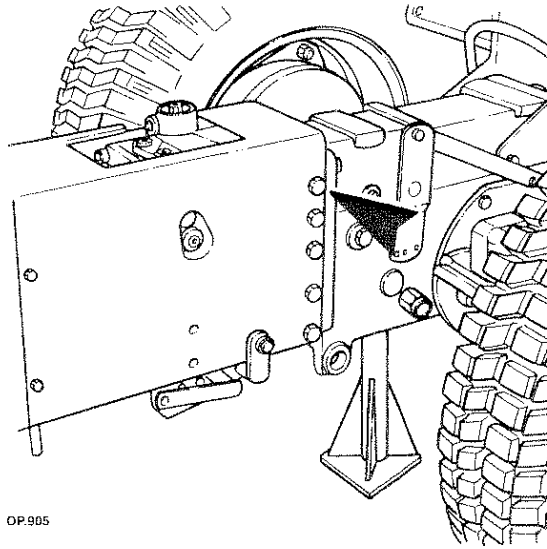

OP.905

31 - Loosen the screws and remove the central body.

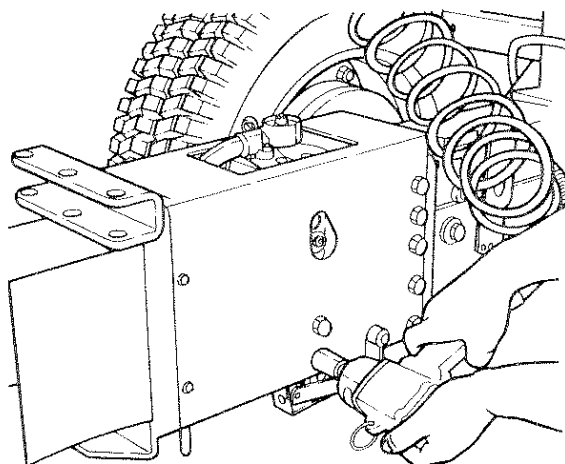

OP.903

29 - Loosen the screws of the extension support and withdraw it from the body by tilting it.

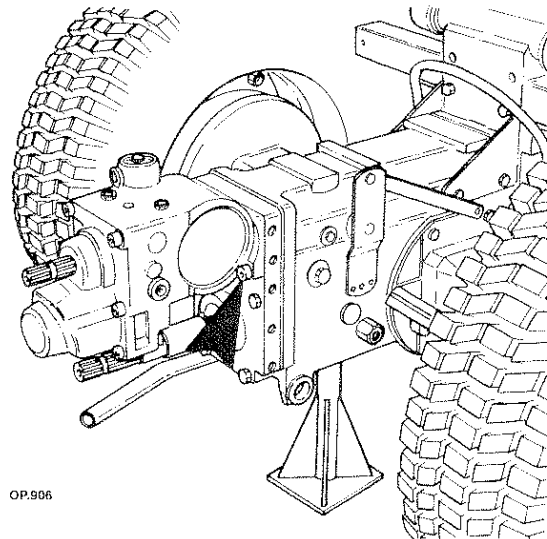

OP.906

32 - Loosen the screws and remove the hydrostatic unit.



WARNING - DANGER



Perform operations by strictly observing accident prevention regulations.

- Use tools to align holes and slots not hands.

Connecting

Proceed to the connection bearing in mind the following instructions:

- a** - reverse the disconnection operations.
- b** - follow the pictures for location of the different components.
- c** - observe the driving torque listed at page 4.
- d** - before inserting the extensions or the universal joints, accurately grease the grooved contours (regarding the type of grease to use refer to page 5).
- e** - tighten the anchoring dowels of the extensions or the joints with the help of Loctite 242 (average strong thread lock).
- f** - clean carefully, especially the surfaces to be mated. Apply a 3 mm string of gasket forming compound following the path indicated in the figure:

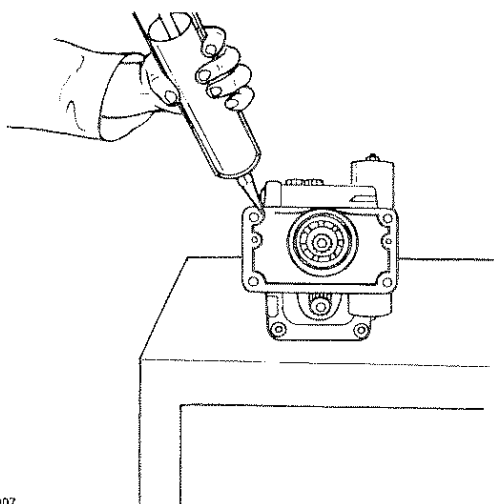

OP.907

Application diagram of gasket forming compound

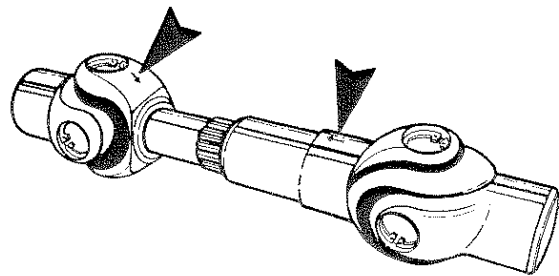

OP.054

g - check the alignment of the central anchoring joint.

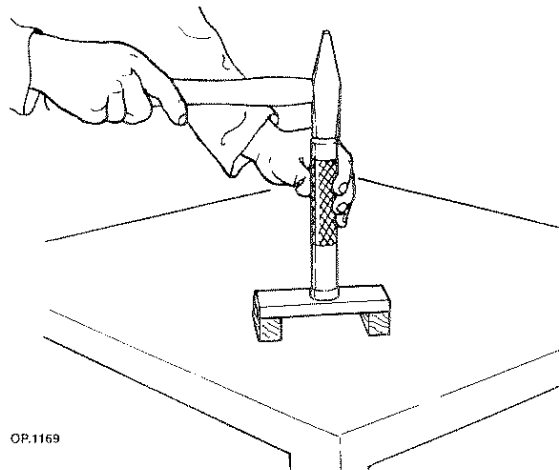

OP.1169

h - use driver AT 37981312 to remove and to mount the roller housing on the central plate.

i - clean all parts that will be in contact with the hydraulic oil of the circuit thoroughly (tank - tubes - heat exchanger).

l - make sure that there are no obstacles that hinder the regular suction of the pump of the hydrostatic unit (stoppers).

m - replace the oil filter cartridge.

n - do not start engine and start the hydrostatic unit before having filled the hydraulic circuit with oil (new).

o - fill the tank (speed gear) with oil, see page 5.

p - fill the hydrostatic unit with oil, see page 5, through one of the drain holes.



WARNING - DANGER



Perform operations by strictly observing accident prevention regulations.
 - Do not use gasoline, diesel oil or other flammable liquids to degrease or clean parts but use commercial non-toxic solvents instead.
 Keep environment clean. Dispose of waste fluids, used filter cartridges, oils, lubricants and grease cleaners in the most suitable way and in compliance with regulations in force.
 The collection of waste oils must be performed by authorized plants.

Tigretrac with cab (with 4 uprights)

To have access to the hydrostatic unit you need to:

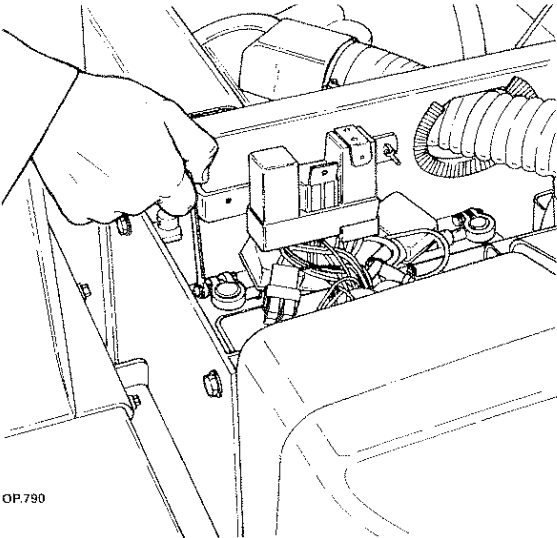

1 - Disconnect the battery wire and insulate it.

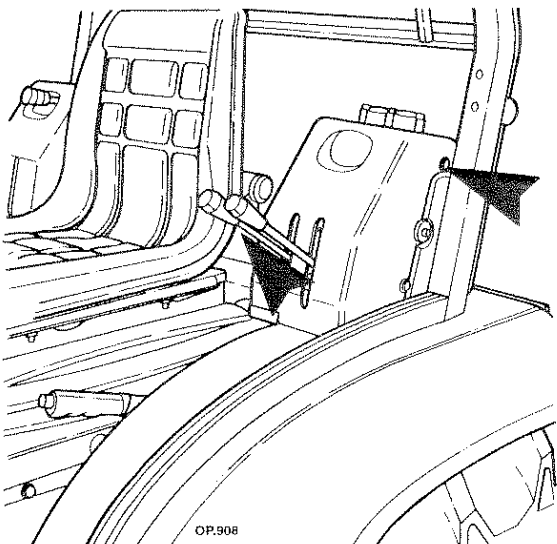

2 - Remove the distributor lever handgrip and the distributor protections.

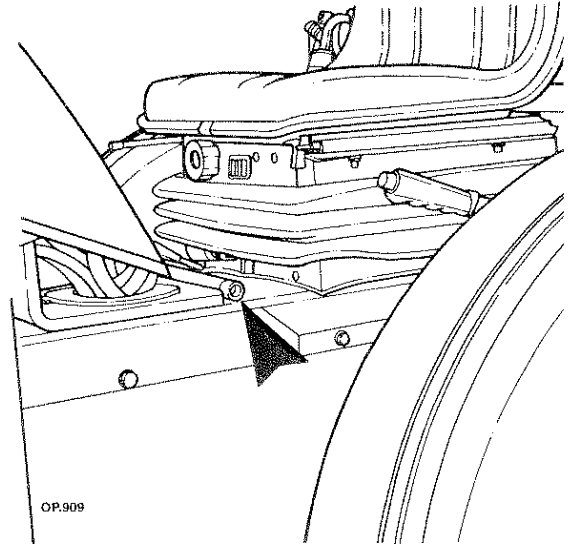

3 - Loosen and remove the whole seat.

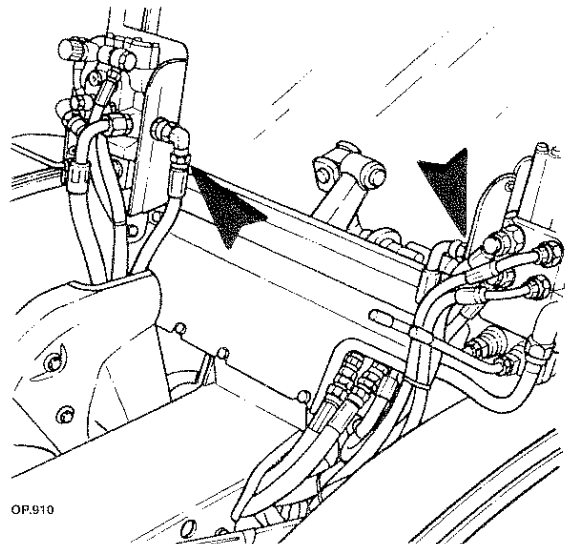

4 - Loosen the unions and remove the delivery tube (connection to distributors).

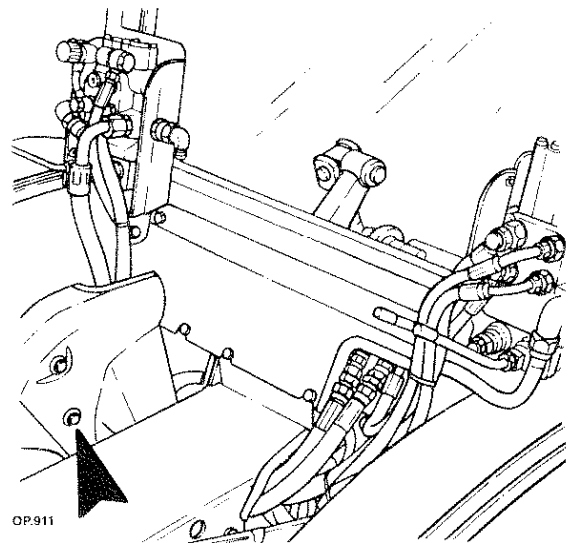

5 - Loosen the screws and remove the protections of the deviator 2 - 4 steering wheels.

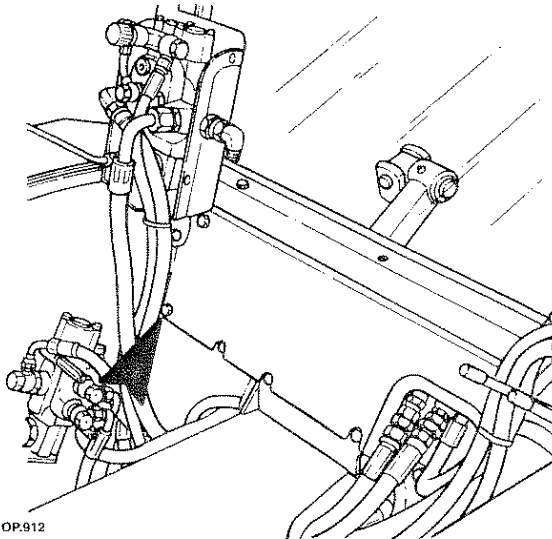

OP.912

6 - Loosen the screws and remove the protections.

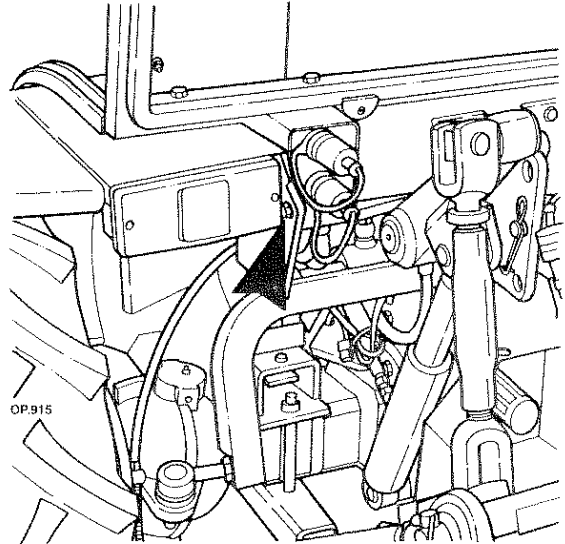

OP.915

9 - Loosen the hydraulic coupling supports and remove them.

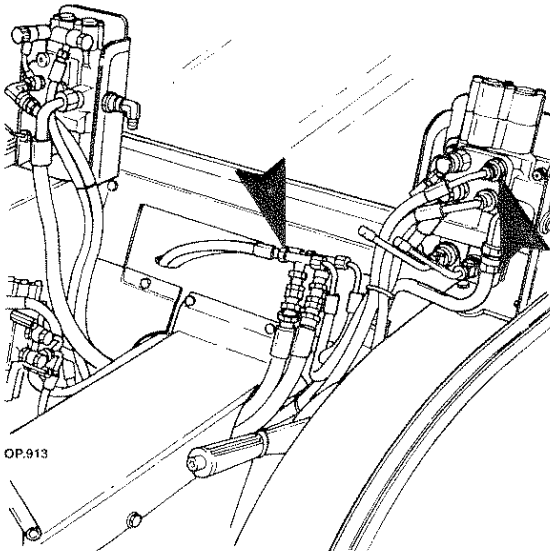

OP.913

7 - Loosen the rear hydraulic coupling connectors.

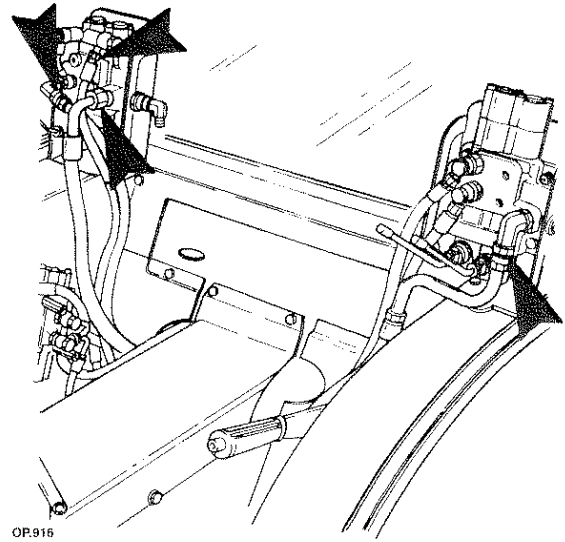

OP.916

10 - Loosen the delivery - drain tub unions.

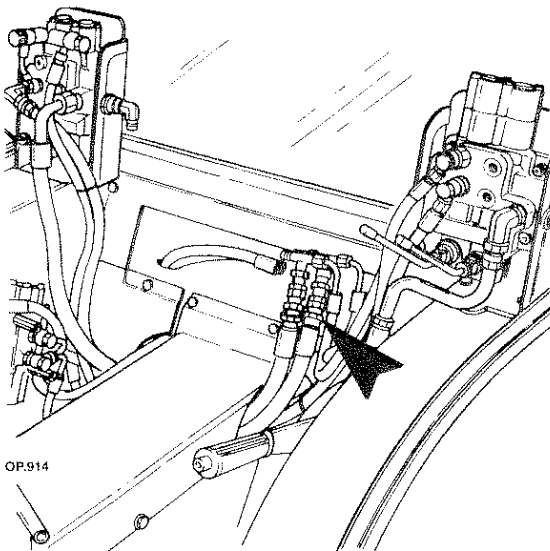

OP.914

8 - Loosen the front hydraulic coupling connectors.

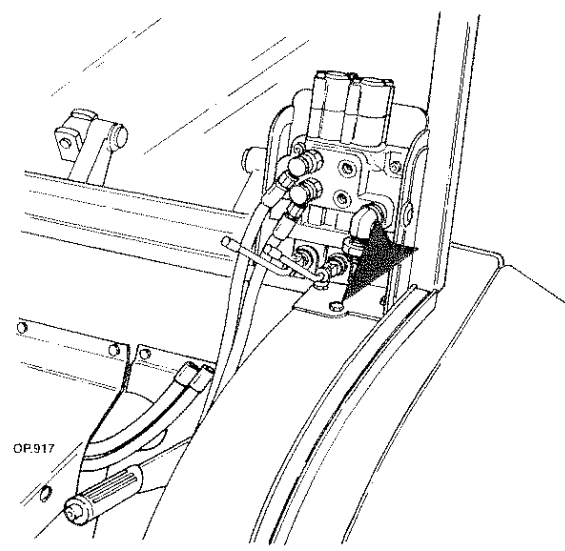

OP.917

11 - Loosen the screws and remove the distributors and relative supports.

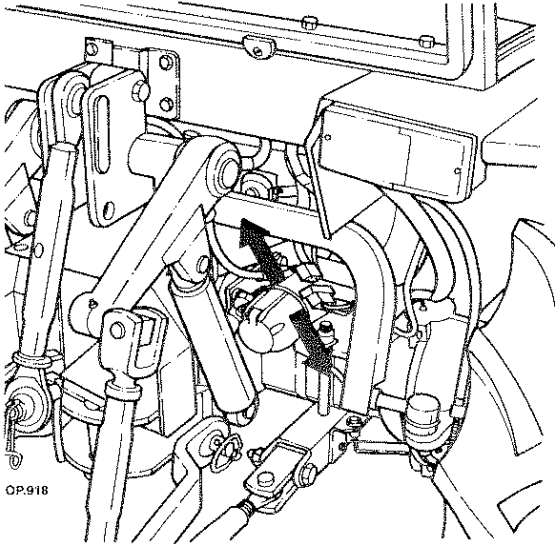

12 - Disconnect the electrical connections of the cab.

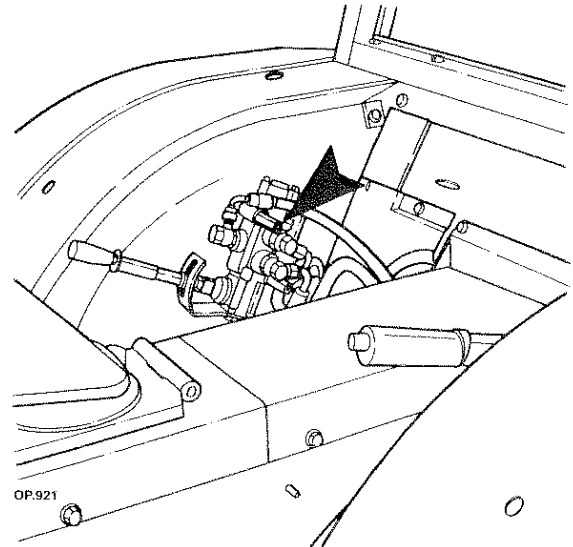

15 - Loosen the screws and remove the deviator for the 4 steering wheels.

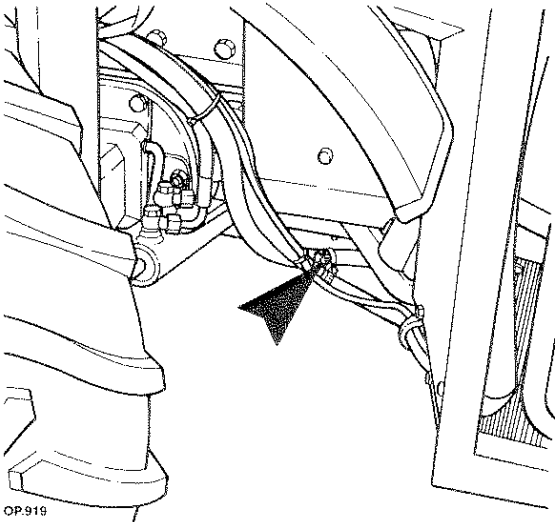

13 - Loosen the tube clamps and disconnect the cab heating tubes then plug holes with stoppers.

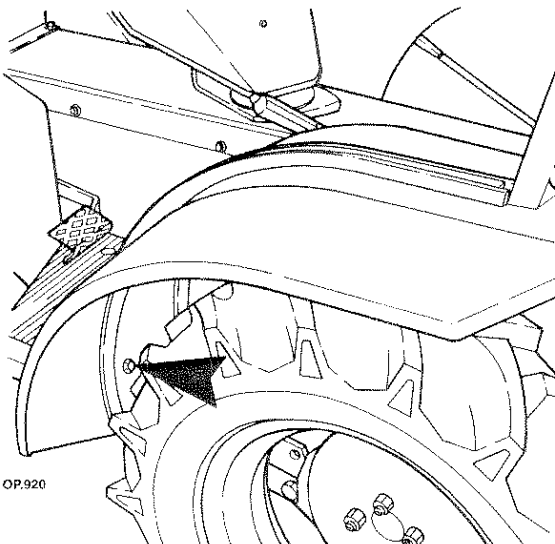

14 - Loosen the screws and remove the door stops on the rear fenders (with cab closed).



WARNING - DANGER



Perform operations by strictly observing accident prevention regulations.

- Use suitable hoisting means.
- Wear gloves to handle metal cords or chains.

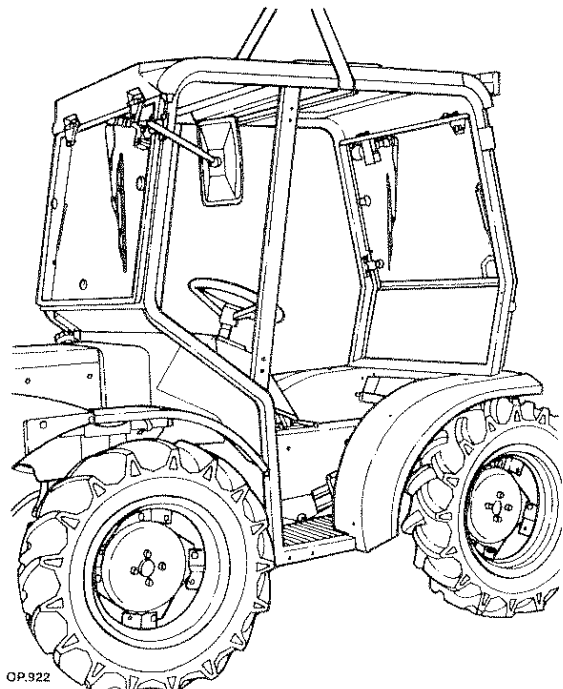

16 - Sling the cab from the back with the help of a hoist.

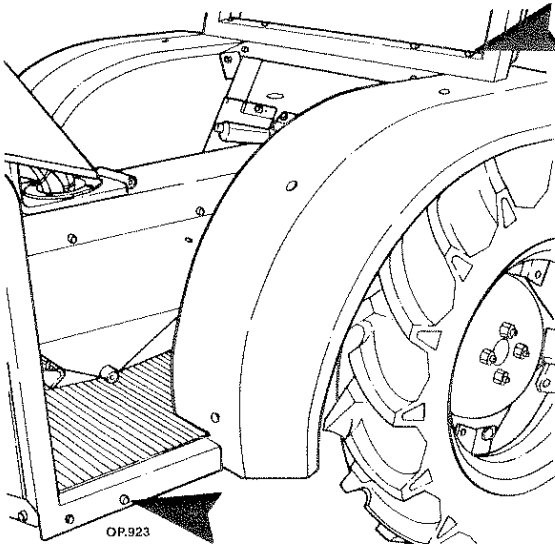

17 - Loosen the safety frame support screws and separate them from the trailer.

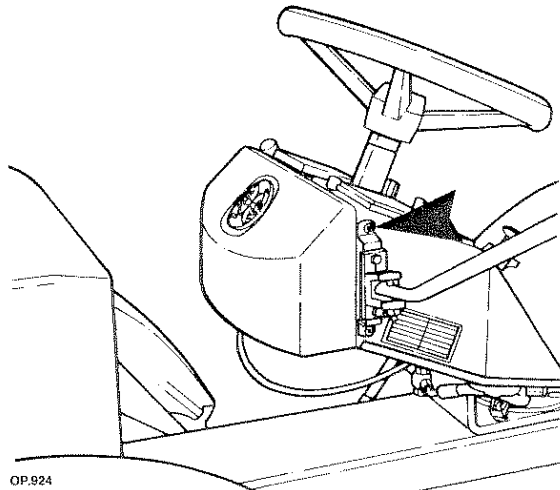

18 - Loosen the screws and remove the cover of the dashboard.

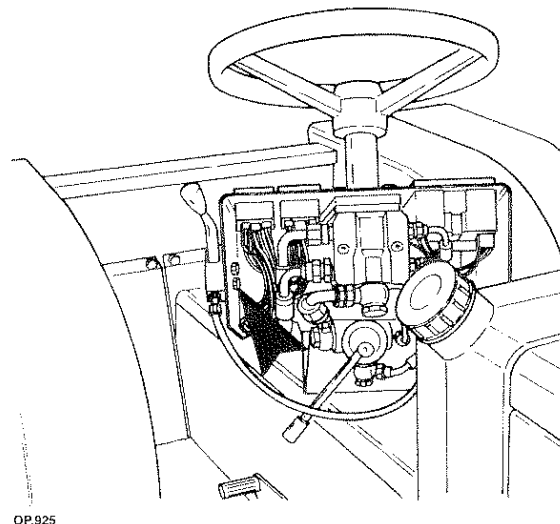

19 - Loosen the screws and remove the gas pedal and the steering wheel.

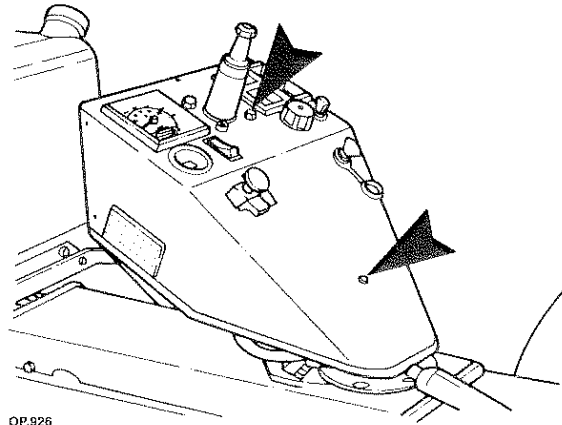

20 - Loosen the clamp and remove the traction disengagement wire, detach the electrical connections, loosen the screws and remove the dashboard.

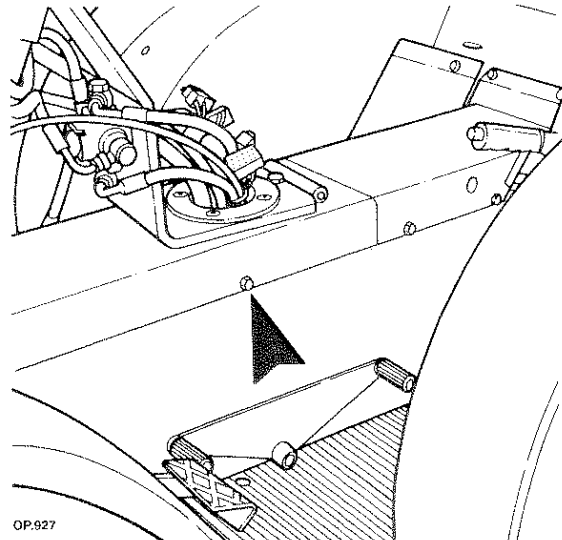

21 - Loosen the screws and remove the revolving platform support, removing the rear electric line and that of the km counter, placing it on the side of the diesel engine.

22 - Remove the spring pins and remove the front - rear of the PTO and speed selector.



WARNING - DANGER



Keep environment clean. Dispose of waste fluids, used filter cartridges, oils, lubricants and grease cleaners in the most suitable way and in compliance with regulations in force. The collection of waste oils must be performed by authorized plants.

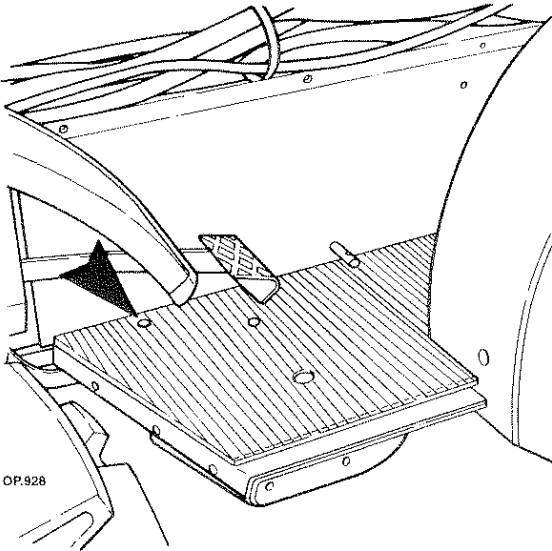

OP.928

23 - Loosen the screws and remove the body cover sides and footrest.

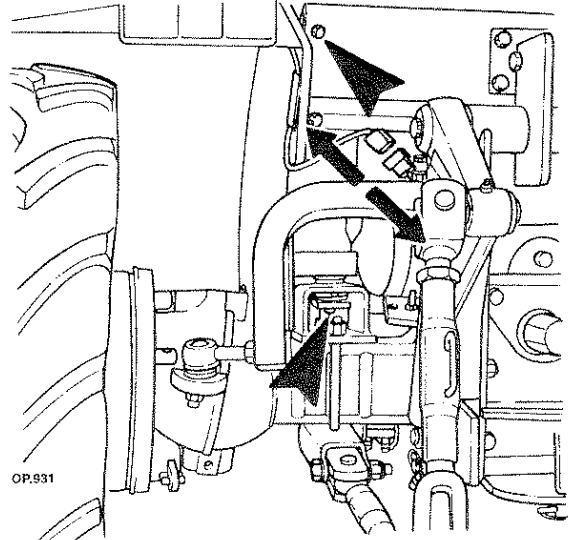

OP.931

26 - Loosen the screws and remove the r.h. and l.h. rear fender by detaching the electrical connections.

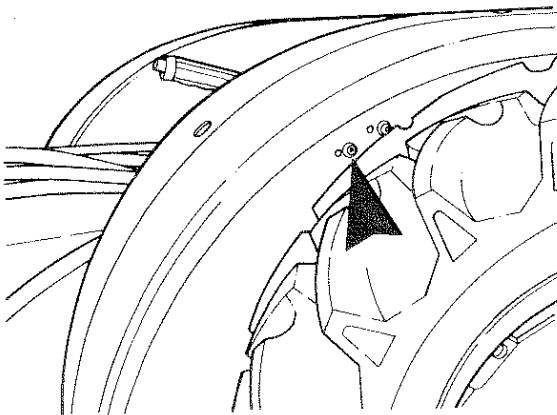

OP.929

24 - Loosen the screws and remove the hand brake support.

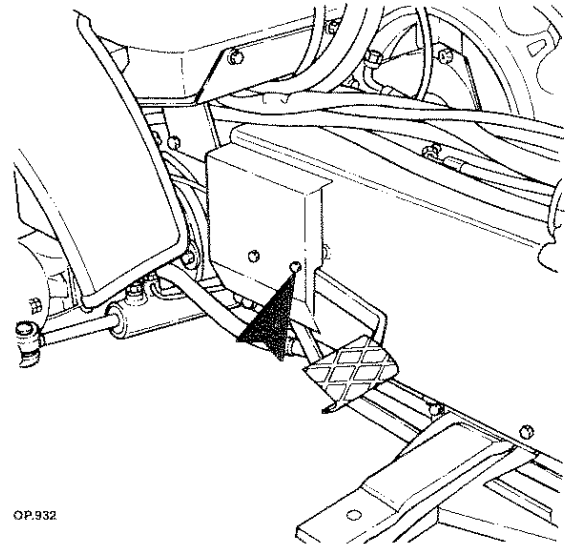

OP.932

27 - Remove the cover of the clutch pedal.

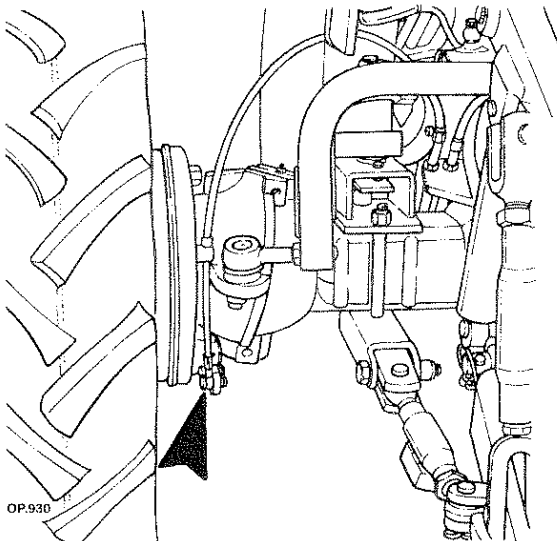

OP.930

25 - Remove the retainer rings and release the brake wires.

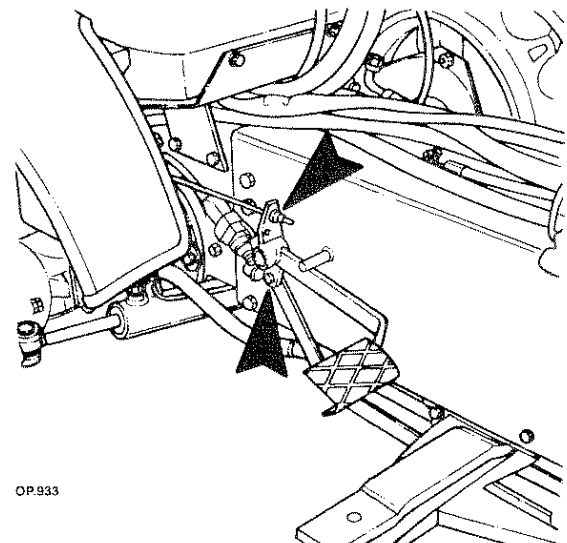

OP.933

28 - Loosen the nut and remove the double control clutch retainer ring by removing the whole pedal.

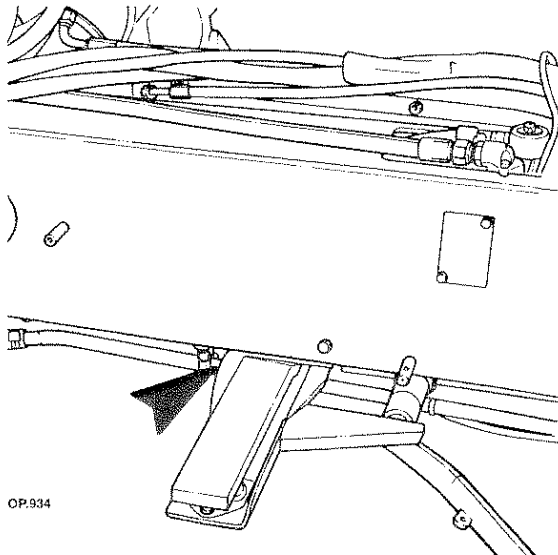

29 - Loosen the screws and remove the frame carrier cross-bar.

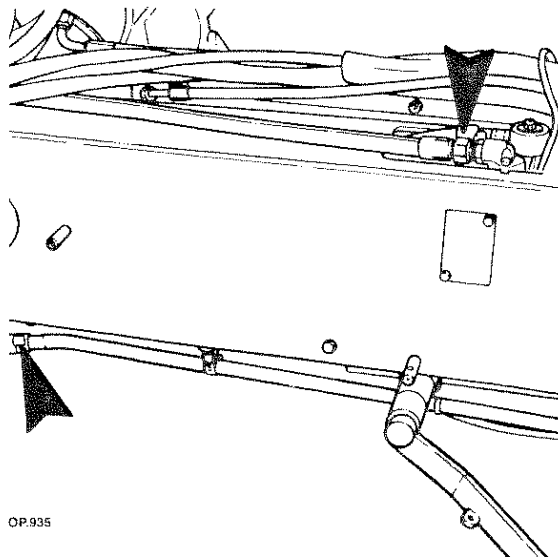

30 - Loosen the tube clamp and the hydrostatic engine connection tube union.

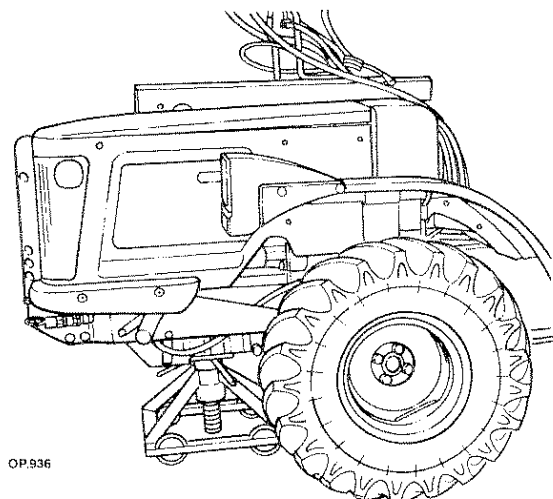

31 - Place a mobile horse underneath the engine and a fixed one underneath the gearbox on the front end.

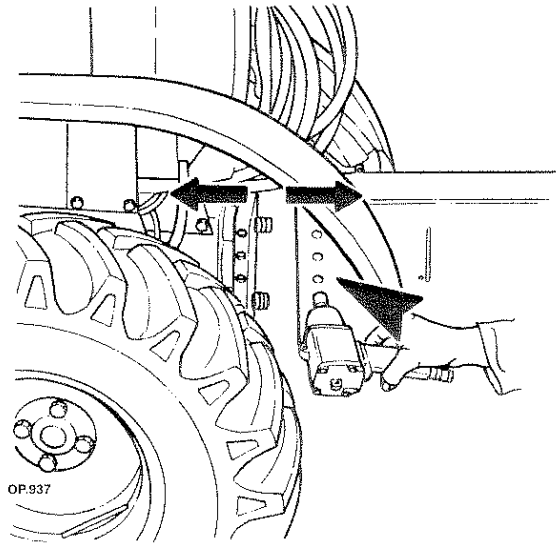

32 - Loosen the screws and separate the fore carriage from the rear unit.

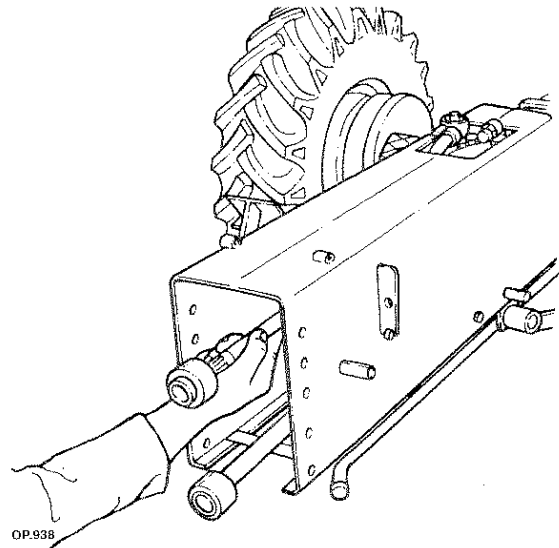

33 - Remove the central extensions.

34 - Loosen the screws and remove the lower protections on the central body.

35 - Remove the split pins and detach the brake connection tie-rods.



WARNING - DANGER



Perform operations by strictly observing accident prevention regulations.

- Wear safety clothing such as, gloves and safety shoes.

- Do not align slots with hands but use specific tools instead.

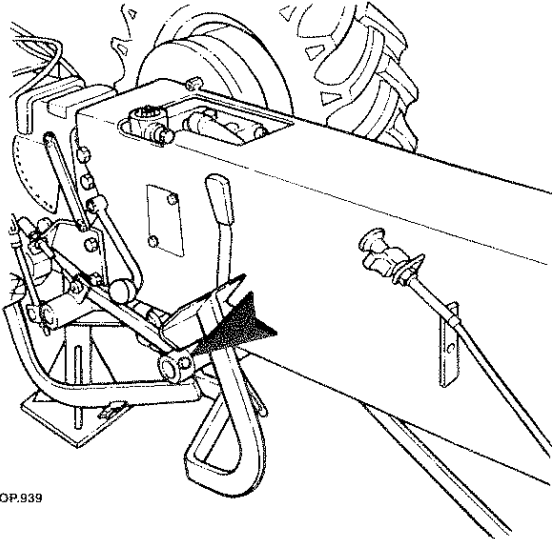

OP.939

36 - Remove the spring pin and withdraw the brake pedals.

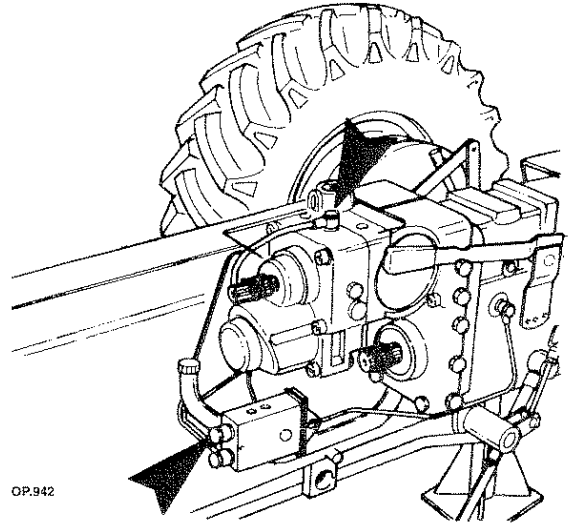

OP.942

39 - Loosen the unions of the joystick connection tube.

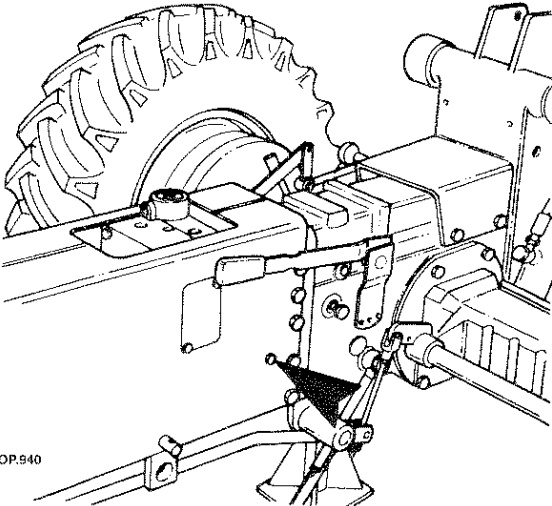

OP.940

37 - Loosen the nut and remove the km counter.

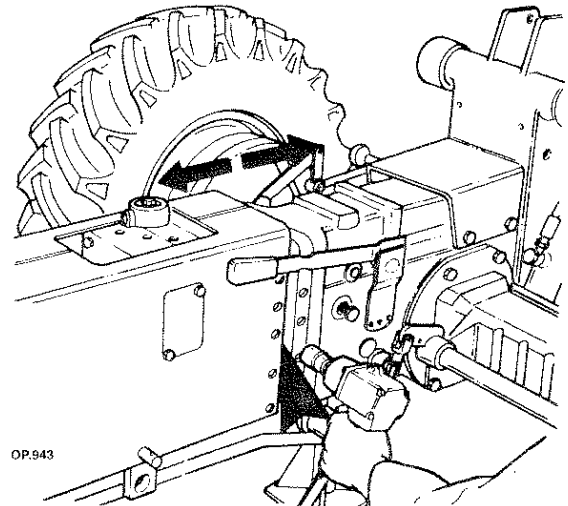

OP.943

40 - Loosen the screws and withdraw the central body.

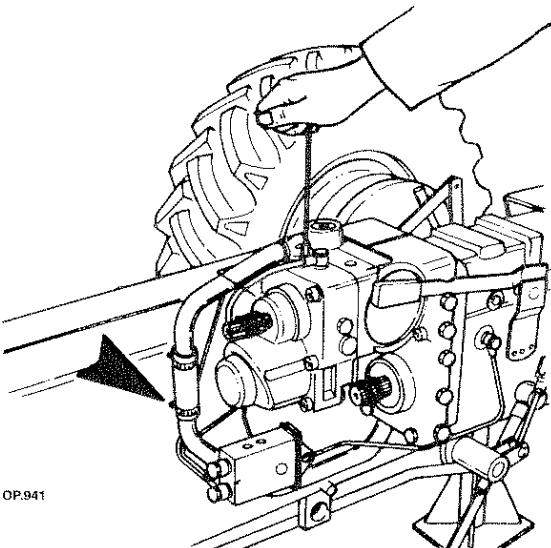

OP.941

38 - Loosen the tube clamp and remove the oil suction tube.

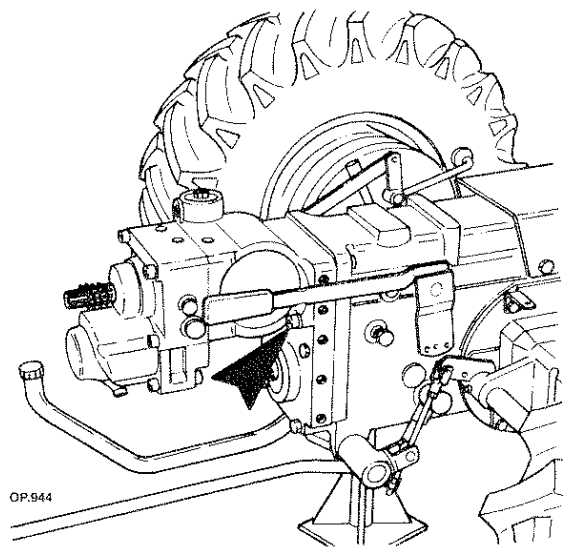

OP.944

41 - Loosen the screws and withdraw the hydrostatic unit.



WARNING - DANGER



Perform operations by strictly observing accident prevention regulations.
 - Use tools to align holes and slots not hands.

Connecting

Proceed to the connection, bearing in mind the following instructions:

- a** - reverse the disconnection operations.
- b** - follow the pictures for location of the different components.
- c** - observe the driving torque listed at page 4.
- d** - before inserting the extensions or the universal joints, accurately grease the grooved contours (regarding the type of grease to use refer to page 5).
- e** - clean carefully, especially the surfaces to be mated. Apply a 3 mm string of gasket forming compound following the path indicated in the figure:

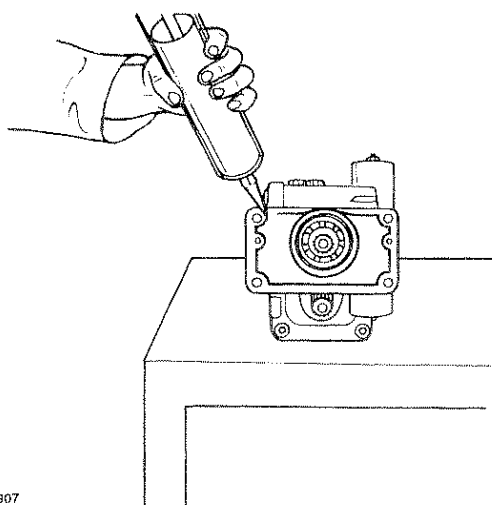

OP.907

Application diagram of gasket forming compound

- f** - clean all parts that will be in contact with the hydraulic oil of the circuit thoroughly (tank - tubes - heat exchanger).

- g** - make sure that there are no obstacles that hinder the regular suction of the pump of the hydrostatic unit (stoppers).

- h** - replace the oil filter cartridge.

- i** - do not start the diesel engine and actuate the hydrostatic unit before having filled the hydraulic circuit with oil (new).

- l** - fill the tank (speed gear) with oil, see page 5.

- m** - fill the hydrostatic unit with oil, see page 5, through one of the drain holes.



WARNING - DANGER



Perform operations by strictly observing accident prevention regulations.
 - Do not use gasoline, diesel oil or other flammable liquids to degrease or clean parts but use commercial non-toxic solvents instead. Keep environment clean. Dispose of waste fluids, used filter cartridges, oils, lubricants and grease cleaners in the most suitable way and in compliance with regulations in force. The collection of waste oils must be performed by authorized plants.

Tigretrac with roll bar

To have access to the hydrostatic unit you need to:

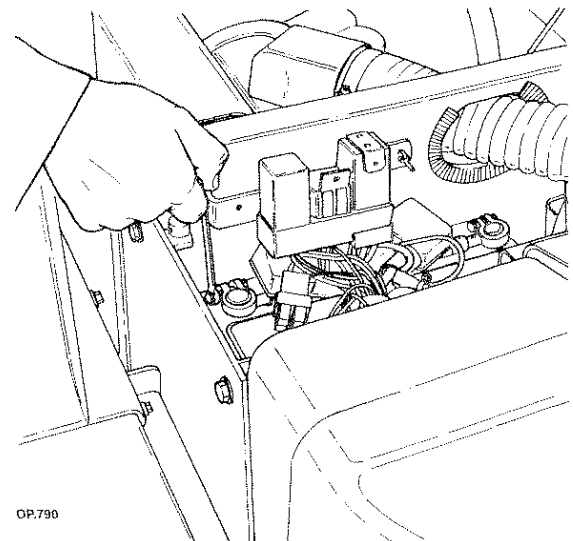

OP.790

- 1** - disconnect the battery wire and insulate it.

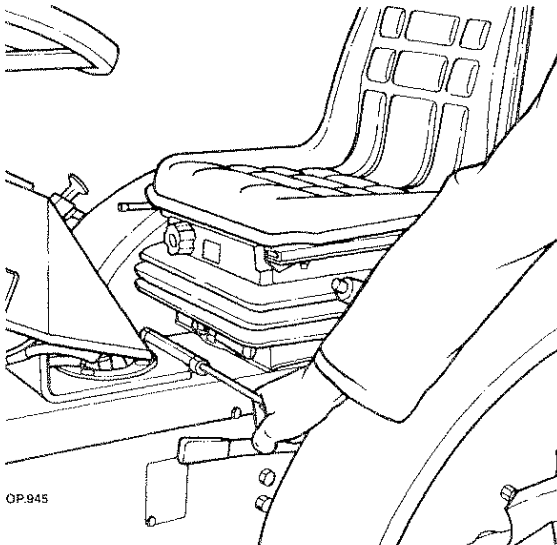

2 - Loosen the screws and remove the whole seat.

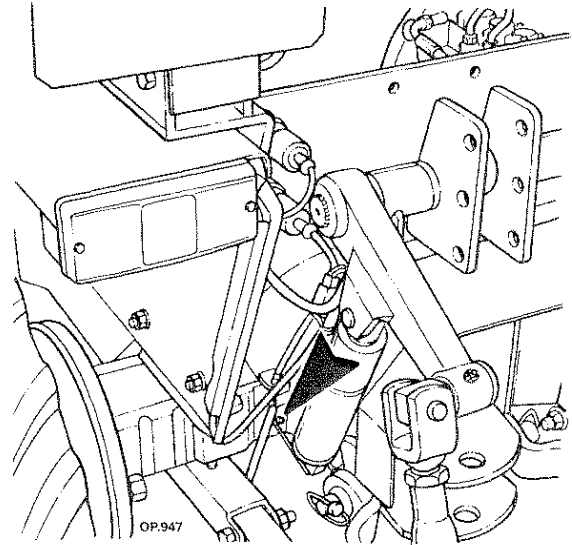

5 - Loosen the clamps and remove the traction disengagement wires and differential locking engagement.

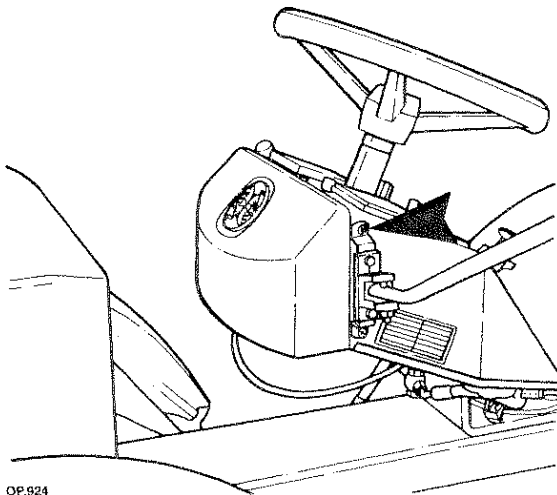

3 - Loosen the screws and remove the dashboard cover.

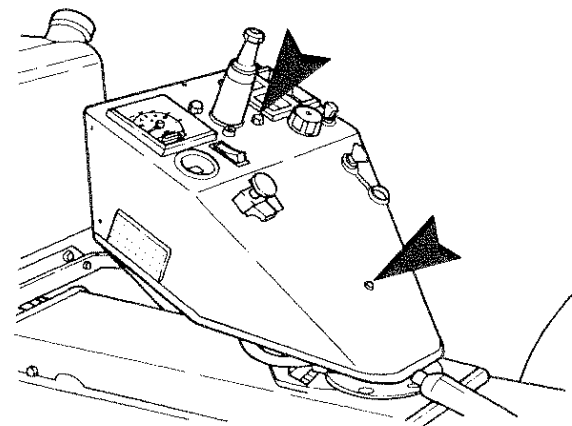

6 - Loosen the dashboard support screws, detach the electric connection and withdraw it.

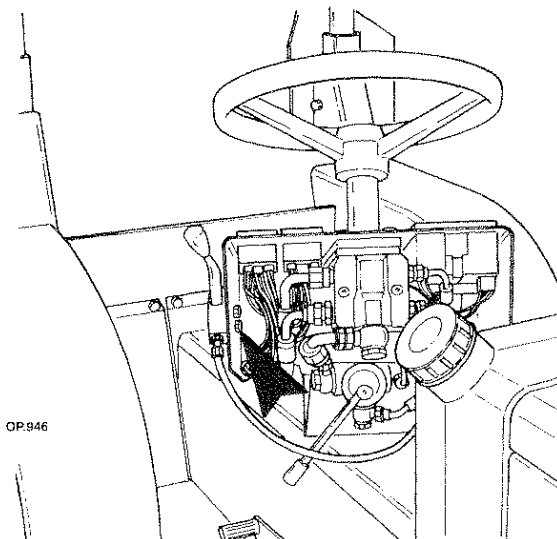

4 - Loosen the screws and remove the gas and steering wheel lever.

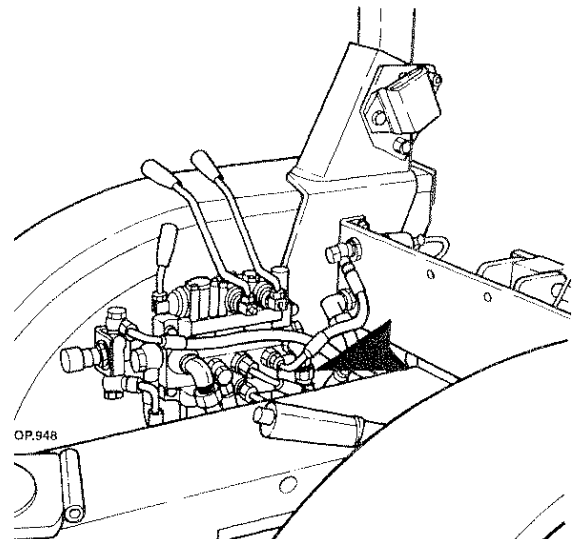

7 - Loosen the tube on the distributor and plug holes with stoppers.

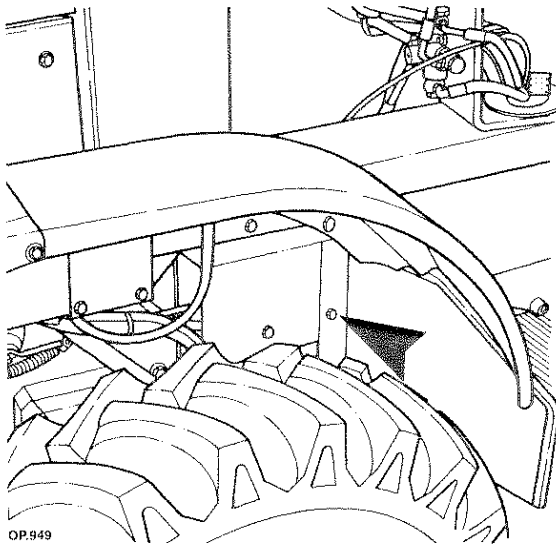

OP.949

8 - Loosen the screws and remove the cover of the revolving platform removing the rear electric line and that of the km counter by placing it towards the diesel engine.

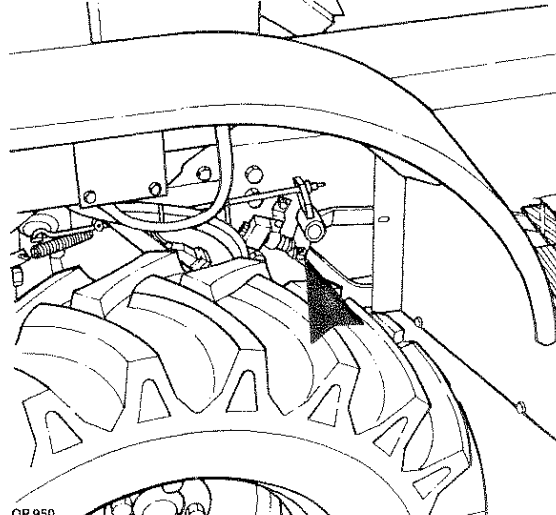

OP.950

9 - Remove the split pins and detach the double control clutch.

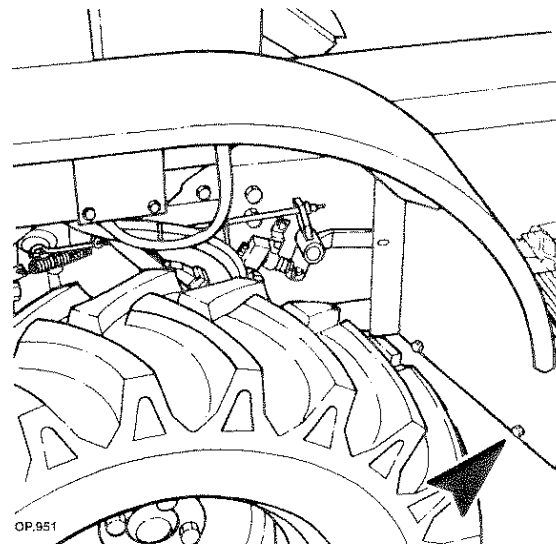

OP.951

10 - Loosen the screws, remove the footrest protection and the clutch pedal.

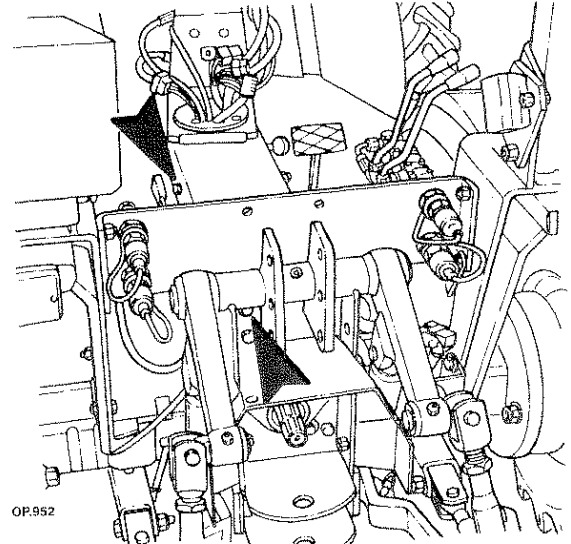

OP.952

11 - Loosen the screws and remove the revolving platform support, removing the rear electric line and that of the km counter, placing it on the side of the diesel engine.

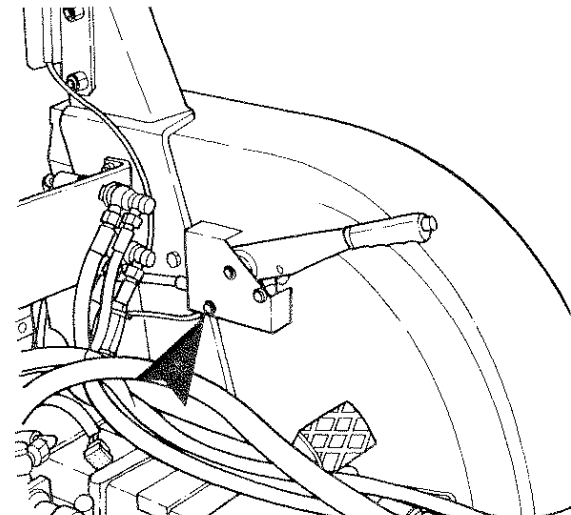

OP.953

12 - Loosen the screws and remove the hand brake.

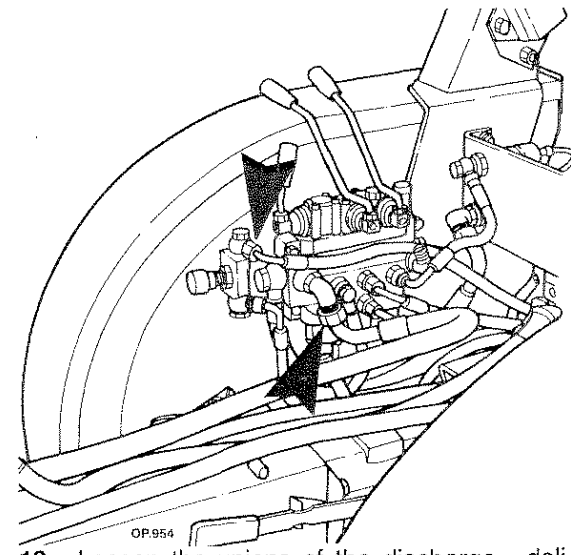

OP.954

13 - Loosen the unions of the discharge - delivery tube and of the cylinders and hydraulic couplings and then plug holes with stoppers.

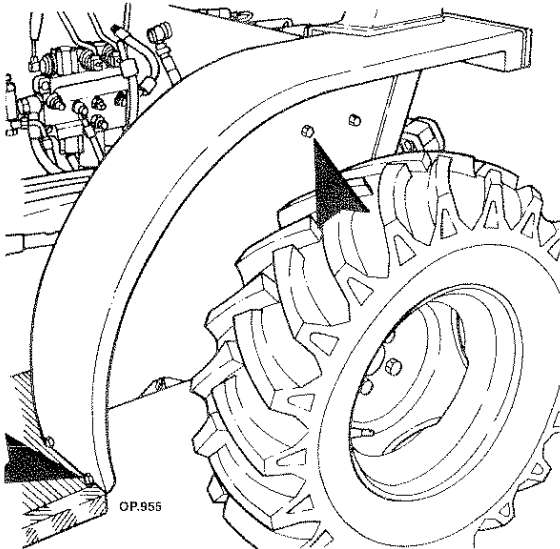

14 - Loosen the screws and remove the rear fenders.

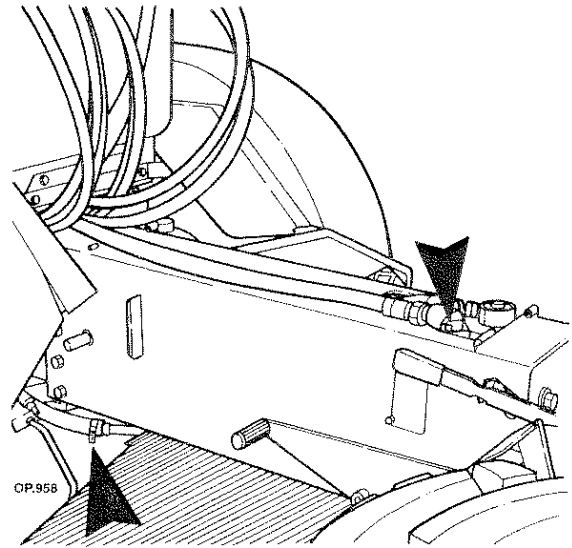

17 - Loosen the clamps and the tube unions of the exchanger hydrostatic unit.

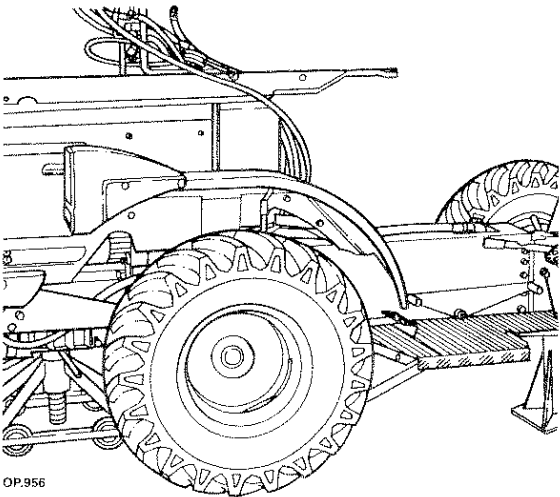

15 - Place a mobile horse underneath the engine and a fixed one underneath the gear-box on the front end.

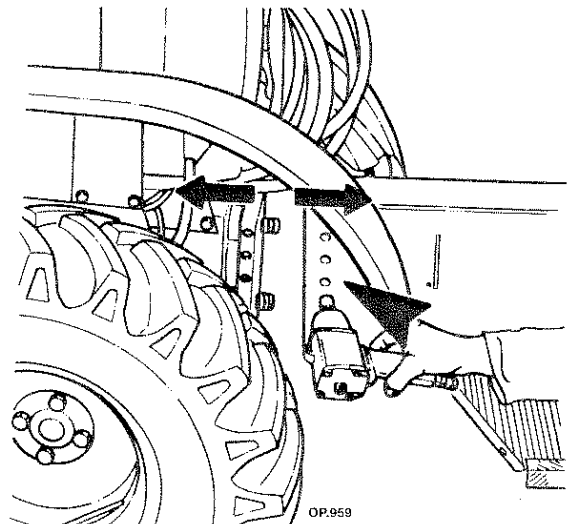

18 - Loosen the screws and separate the forecarriage from the rear hydrostatic unit gear change.

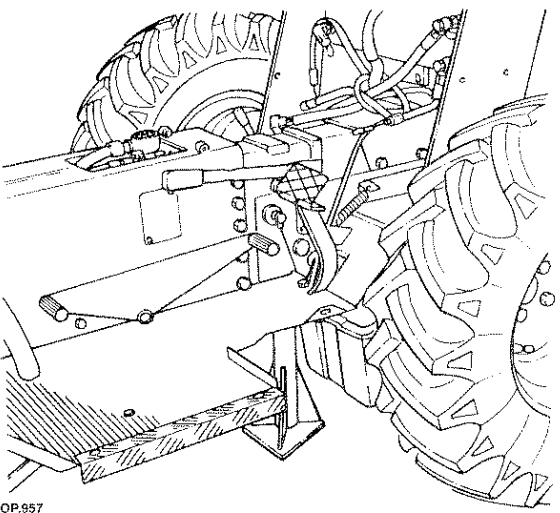

16 - Discharge oil in a special container.

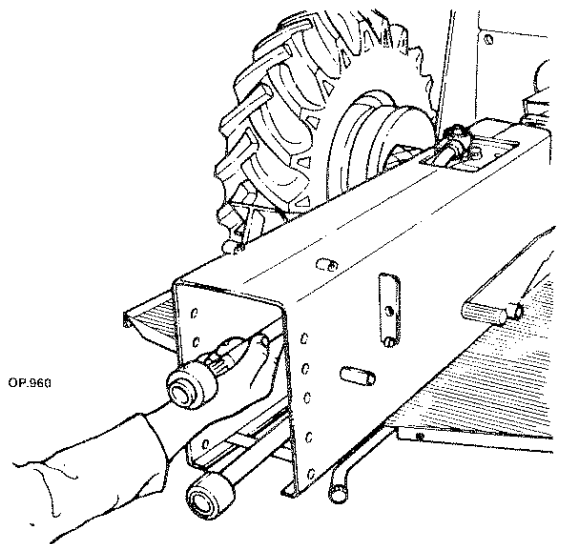

19 - Remove the central extensions.

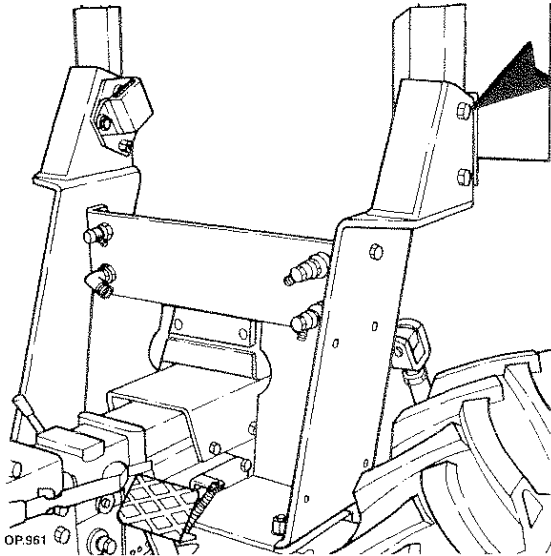

20 - Loosen the screws of the roll bar.

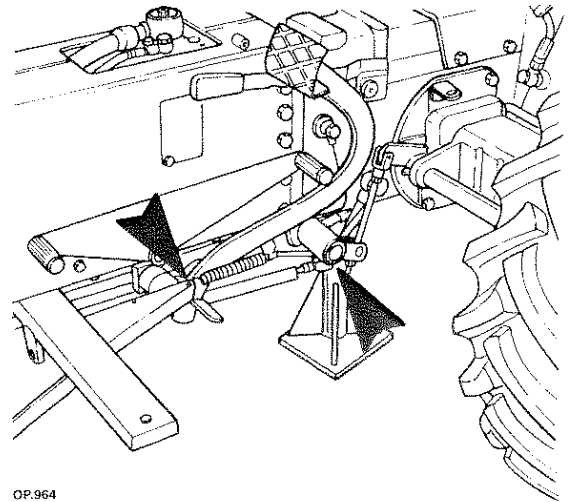

23 - Remove the split pins and detach the brake connection tie-rods.

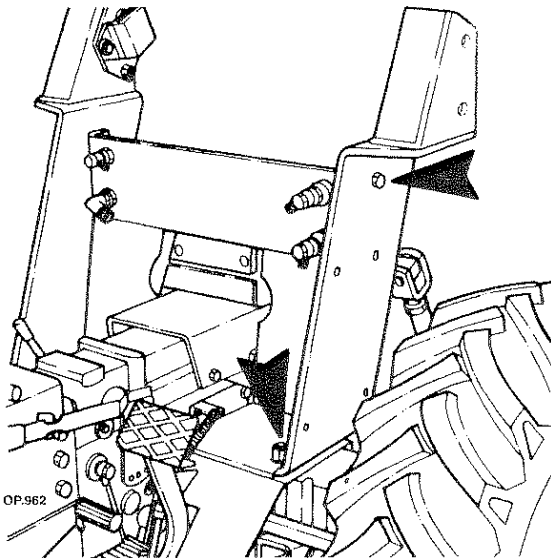

21 - Loosen the screws of the roll bar support.

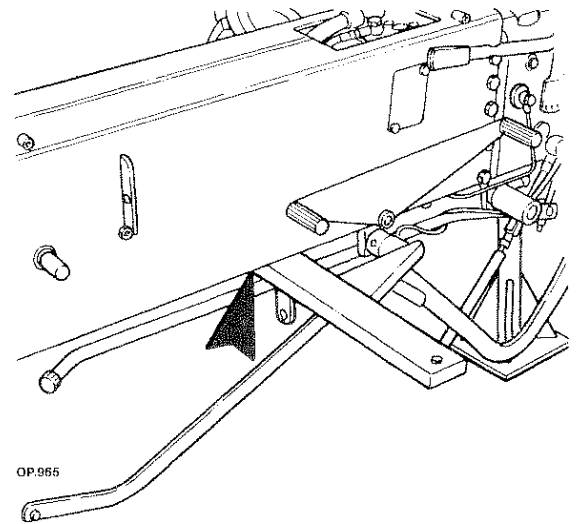

24 - Loosen the screws and remove the footrest support.

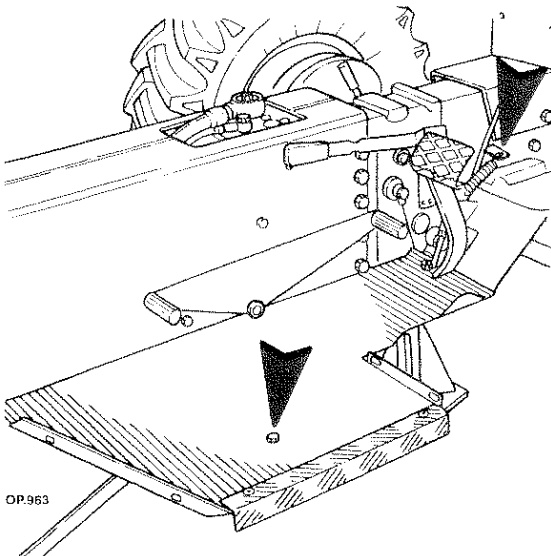

22 - Remove the brake pedal return spring and loosen the screws then remove the footrest.

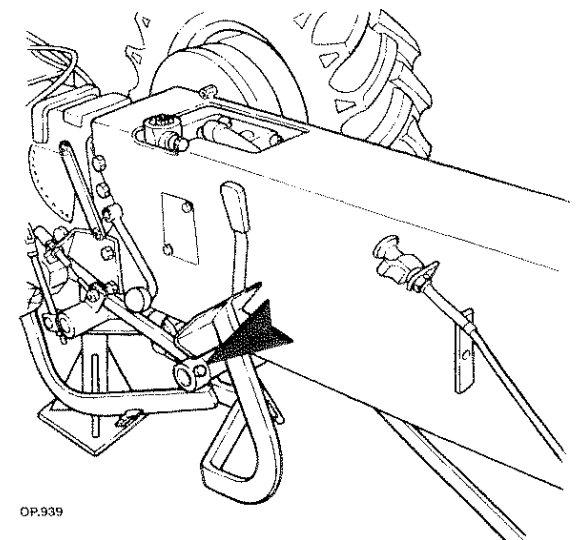

25 - Remove the spring pin and remove the brake pedal.

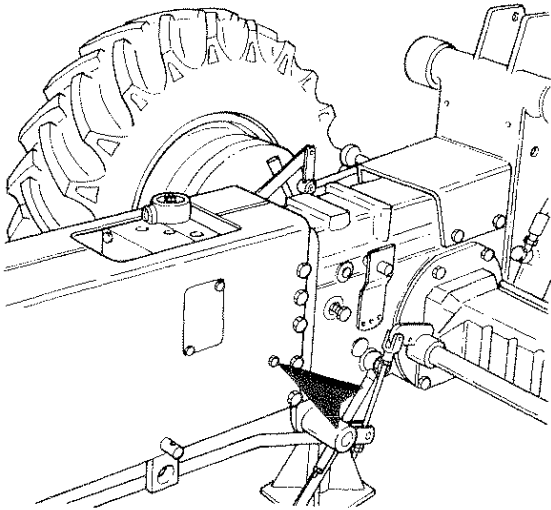

OP.966

26 - Loosen the nut and remove the km counter.

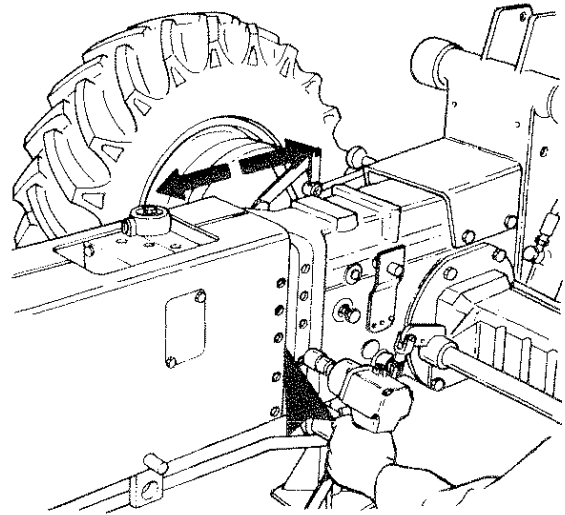

OP.969

29 - Loosen the screws and remove the central body.

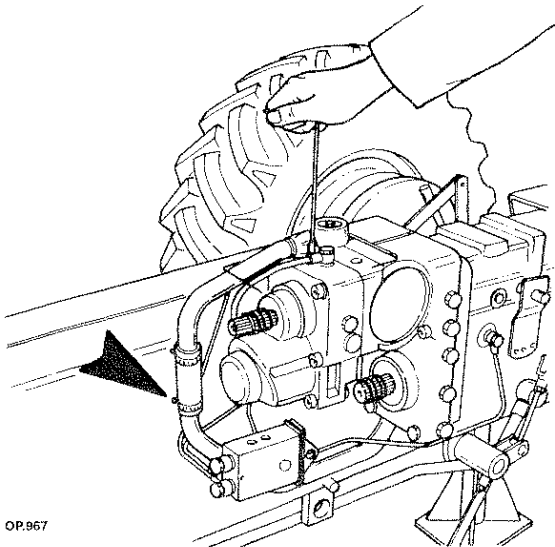

OP.967

27 - Loosen the tube clamp and remove the oil suction tube.

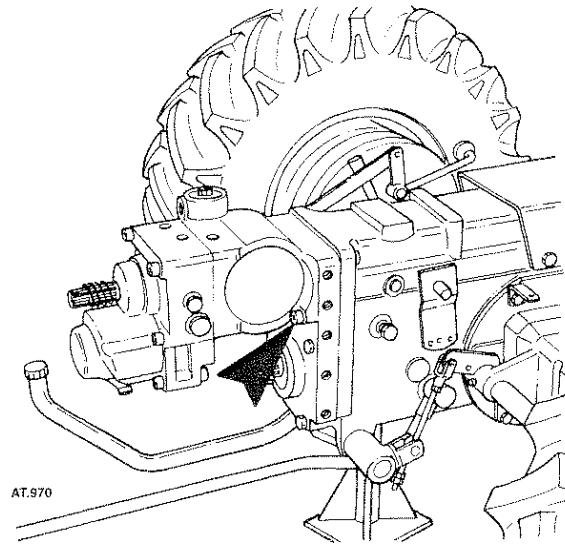

AT.970

30 - Loosen the screws and withdraw the hydrostatic unit.

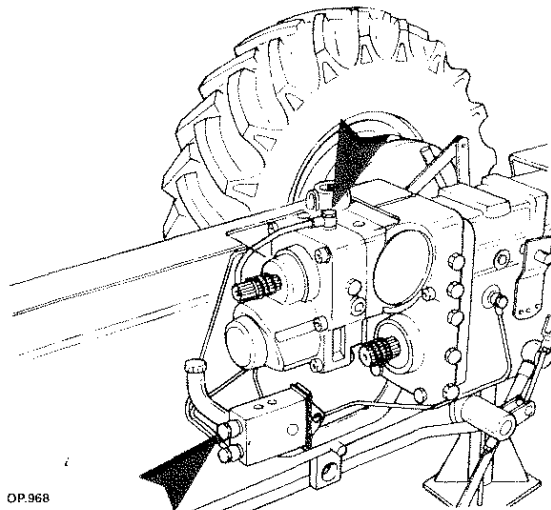

OP.968

28 - Loosen the unions and remove the tubes from the joystick.



WARNING - DANGER



Perform operations by strictly observing accident prevention regulations.

- Wear safety clothing such as, gloves and safety shoes.



WARNING - DANGER



Perform operations by strictly observing accident prevention regulations.
 - Use tools to align holes and slots not hands.

Connecting

Proceed to the connection, bearing in mind the following instructions:

- a. reverse the disconnection operations.
- b. follow the pictures for location of the different components.
- c. observe the driving torque listed at page 4.
- d. before inserting the extensions or the universal joints, accurately grease the grooved contours (regarding the type of grease to use refer to page 5).
- e. clean carefully, especially the surfaces to be mated. Apply a 3 mm string of gasket forming compound following the path indicated in the figure:

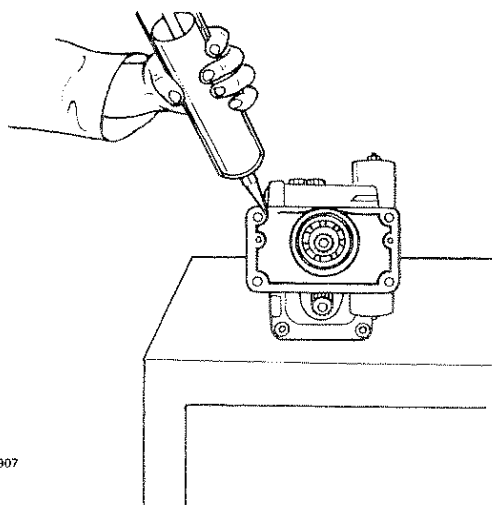

OP.307

Application diagram of gasket forming compound

f - clean all parts that will be in contact with the hydraulic oil of the circuit thoroughly (tank - tubes - heat exchanger).

g - make sure that there are no obstacles that hinder the regular suction of the pump of the hydrostatic unit (stoppers).

h - replace the oil filter cartridge.

i - do not start the diesel engine and actuate the hydrostatic unit before having filled the hydraulic circuit with oil (new).

l - fill the tank (speed gear) with oil, see page 5.

m - fill the hydrostatic unit with oil, see page 5, through one of the drain holes.



WARNING - DANGER



Perform operations by strictly observing accident prevention regulations.

- Do not use gasoline, diesel oil or other flammable liquids to degrease or clean parts but use commercial non-toxic solvents instead.

Keep environment clean. Dispose of waste fluids, used filter cartridges, oils, lubricants and grease cleaners in the most suitable way and in compliance with regulations in force. The collection of waste oils must be performed by authorized plants.

NOTE:

To join the front transmission with the rear one you must:

- 1 - Key the shaft or upper joint.
- 2 - Key the shaft or lower joint as you possibly can.
- 3 - Lift an axle until you can rotate a wheel and recover a few turns on the front and rear transmission.
- 4 - Join the whole.



CGS28 HYDROSTATIC UNIT SECTION

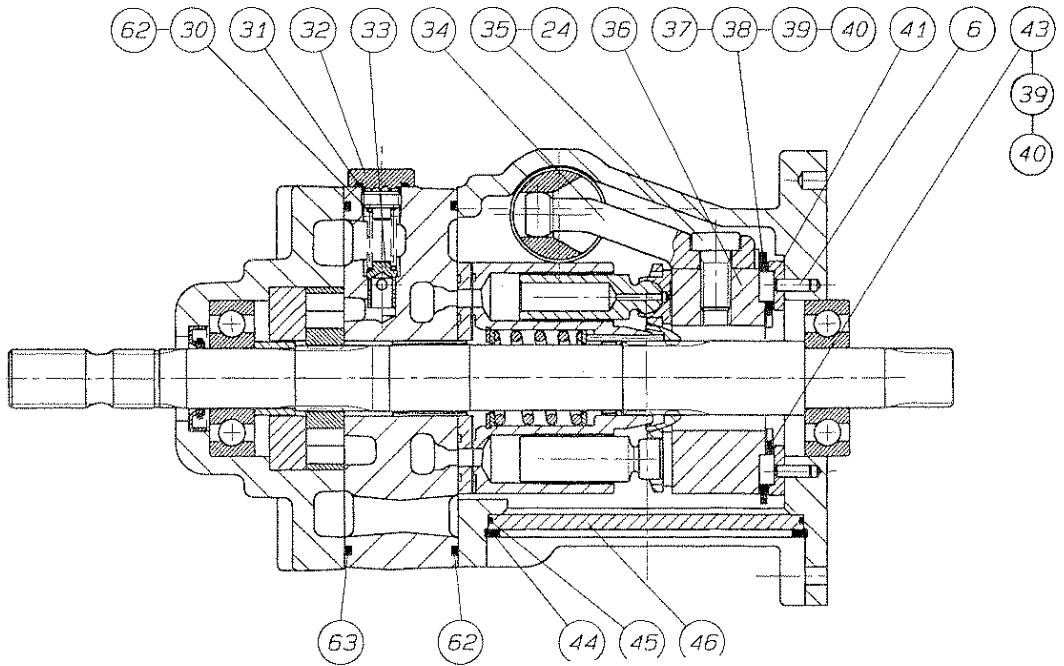
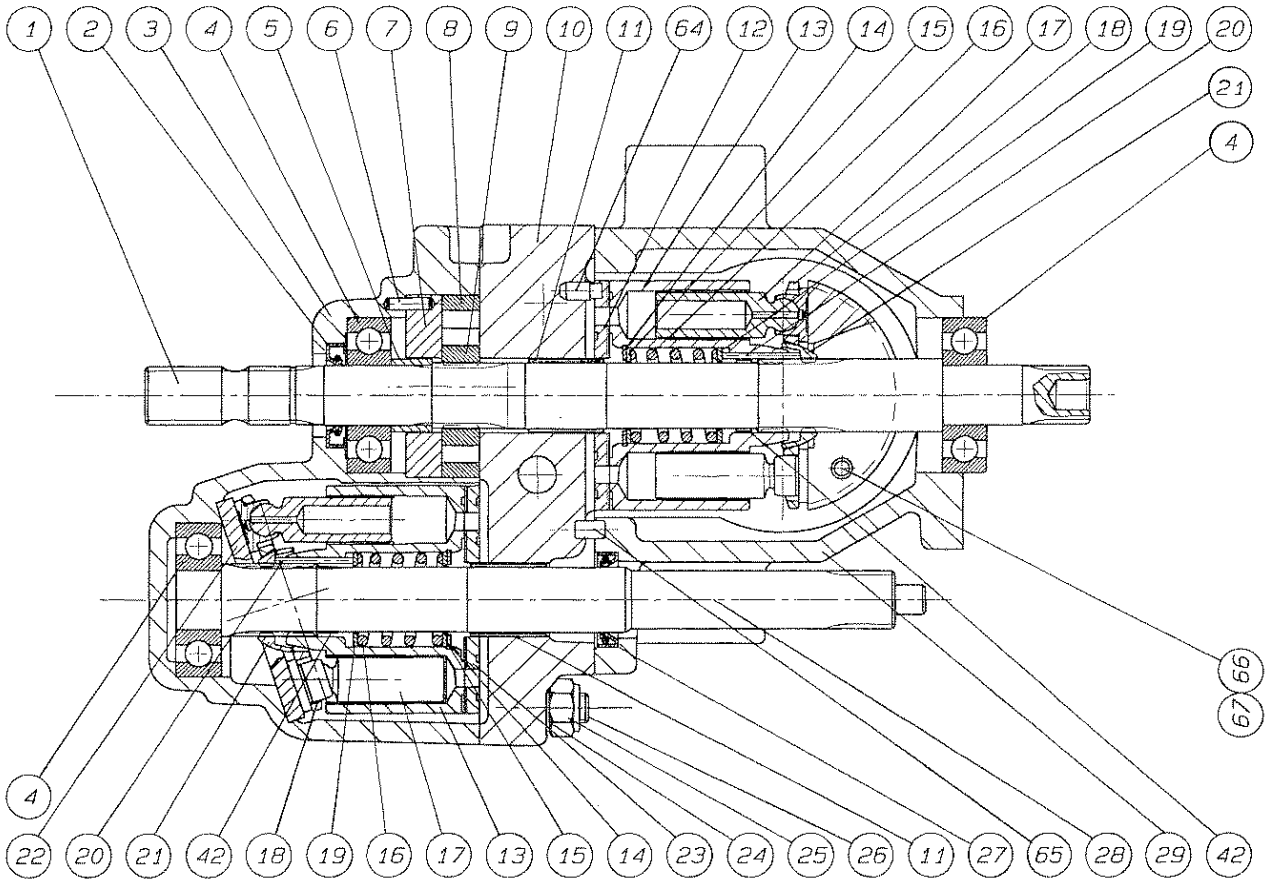



Cross section of the servo control

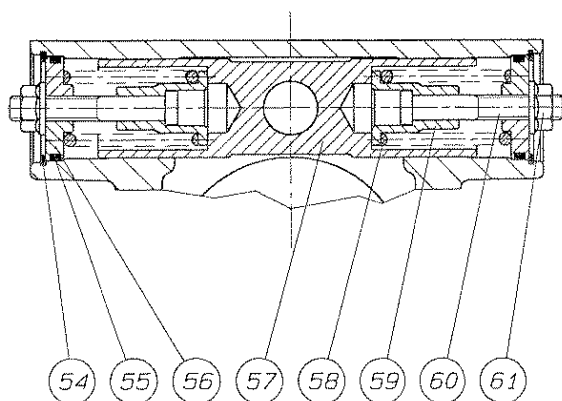

Cross section of the maximum pressure valves

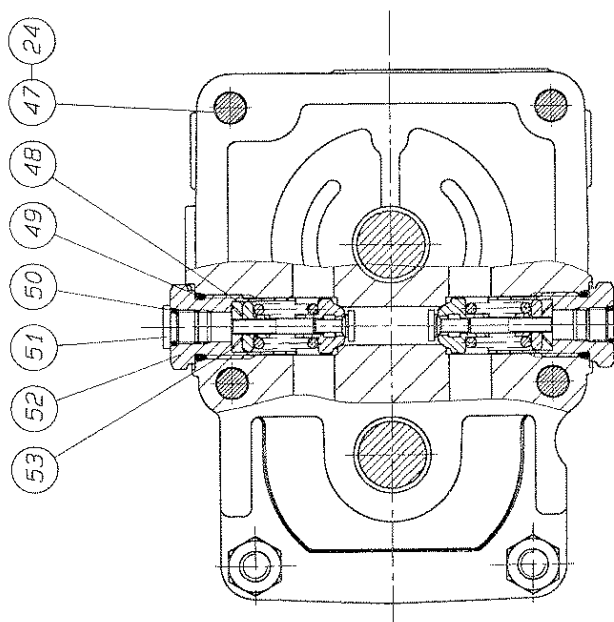

POS. DESCRIPTION

001.	PUMP SHAFT CGS28	035	TCEI SCREW M10X20 DIN7984 (T.RIB.)
002.	SEAL RING BAB1SL 20X35X6-6.5	036	OSCILLATING BODY CGS28
003.	MOTOR CASING CGS28	037	PERFORATED PLUG STEI M10X12 2.1
004.	BALL BEARING 6304 QEV277 (20X52X15)	038	R.H. ROLLER HOUSING UNIT M4PV58
005.	FEED PUMP CENTRAL SPACER CGS28	039	BEARING WIRE T30-M4PV58
006.	PIN 4X14 H8 UNI707	040	PERFORATED ROLLER FOR HOUSING PHASE T30
007.	FEED PUMP CENTRING CGS28	041	ROLLER SLIDING SEMISHELL PV30
008.	OUTER ROTOR H12.5 CGS28	042	PIN STOP BAND SPRING PV20
009.	INNER ROTOR H12.5 CGS28	043	L.H. ROLLER HOUSING UNIT M4PV58
010.	INTERMEDIATE DISTRIBUTOR CGS28	044	INTERMEDIATE SPRING RING D. 107 BR107INA
011.	BUSHING MBI CB85-2225 D 22X25	045	O-RING 1.78X101.32 2-045 COVER CGS28 COVER M5PV75-100
012.	DISTRIBUTOR PLATE M4PV28-CGS228 SX	046	PUMP CLOSING COVER CGS28
013.	CYLINDER BLOCK UNIT M4PV28	047	TCEI SCREW M10X70 UNI5931
014.	INTERMEDIATE SPRING SNAP RING 32 UNI7437	048	HP MAX.PRESSURE VALVE 300 BAR
015.	SPACER 26X32X1.5 CYLINDER BLOCK T20	049	OR 2.62X17.12 90XSH 2-115 VALMAX
016.	CYLINDER BLOCK SPRING T20	050	OR 1.83X8.92 3-904 90XSH SAE 7/16" UNF
017.	COMPLETE PISTON UNIT M4PV28	051	PLUG TCEI SAE 7/16" - 20 - UNF
018.	PAD PRESSING PLATE M4PV28	052	VALVE PLUG MT WITH PRESSURE COUPLING
019.	CYLINDER BLOCK WASHER PV20 23X32X1.5	053	TAPERED SPRING MAX. VALVE SPECIAL WIRE DO.8
020.	ROLLER 2X27 (MF20)	054	INNER SPRING SNAP RING 35 UNI7437
021.	BALL JOINT M4PV28	055	O-RING 2.62X28.24 2-122 SIDE CLAMPING COVER CGS28
022.	THRUST PLATE M4MF28	056	LOCKING DISK SC CGS28
023.	DISTRIBUTOR PLATE M4MF28	057	SERVOCONTROL PINSTON CGS28
024.	WASHER SCHNORR 10	058	SERVOCONTROL PISTON SERVO CGS28
025.	SELF-LOCKING NUT M10	059	PISTON ADJUSTMENT SCREW SC T30
026.	SCREW TCEI M10X55 UNI5931	060	SEAL RING DSL 8
027.	SEAL RING BABSL 22X32X7-7.5	061	O-RING 2.62X139.37 2-161 DISTRIBUTOR CGS28
028.	MOTOR SHAFT CGS28	062	FLAT WASHER 4.3X9 UNI6592-69
029.	PUMP BODY CGS28	063	O-RING 2.62X152.07 2-163 DISTRIBUTOR CGS28
030.	ZERO-SETTING SPRING PV20	064	DISTRIBUTOR PLATE PIN T20
031.	O-RING 1.78 X 142 - 015 90XSH PLUG FEED VALVE 1/4	065	PIN 6X10 H8 UNI1707
032.	PLUG 174 GAS FEED VALVE M4PV58 NEW	066	HOUSING PHASE PIN BUSHING
033.	FEED VALVE PISTON M4PV58 NEW	067	HOUSING PHASE PIN M4PV58
034.	OSCILLATING CONTROL VALVE CGS28		



Disassembly - Assembly of the hydrostatic unit

Before proceeding to the dismantling of the hydrostatic unit it is important to observe the following information:

a - Carefully clean the outside of the unit and prevent dust, dirt etc.. from penetrating inside the unit.

b - Place parts of the unit onto a clean work surface and make sure not to mix them up.

c - Do not use rags or cloth to clean parts but use special cleaning paper.

d - Keep environment clean. Dispose of waste fluids, used filter cartridges, oils, lubricants and grease cleaners in the most suitable way and in compliance with regulations in force.

The collection of waste oils must be performed by authorized plants.

e - Proceed as follows:

1 - Place the unit on a work bench

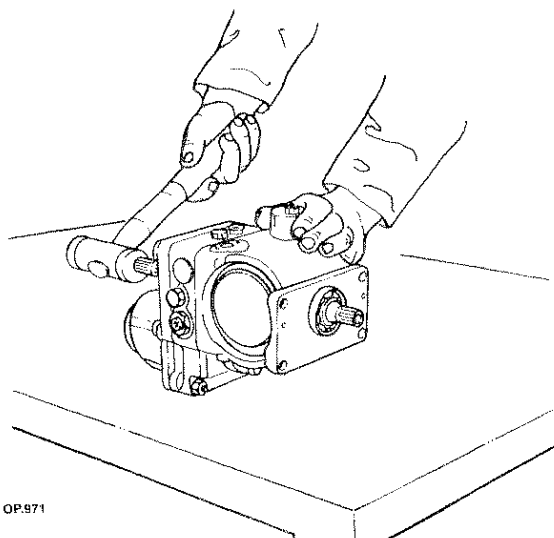

2 - Remove shaft with a hammer

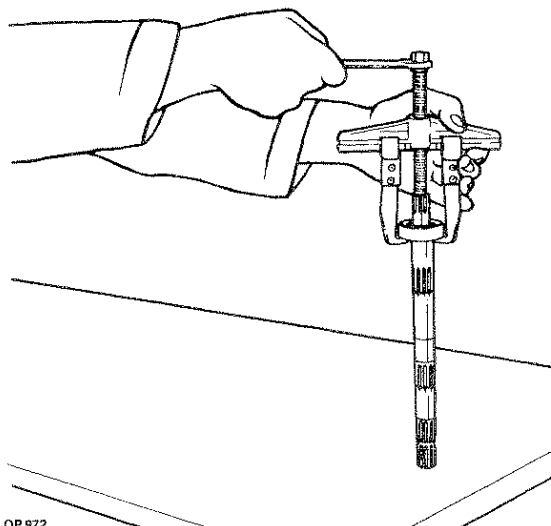

OP.972

3 - Remove the bearing on the main shaft using the universal puller AT 37981257.

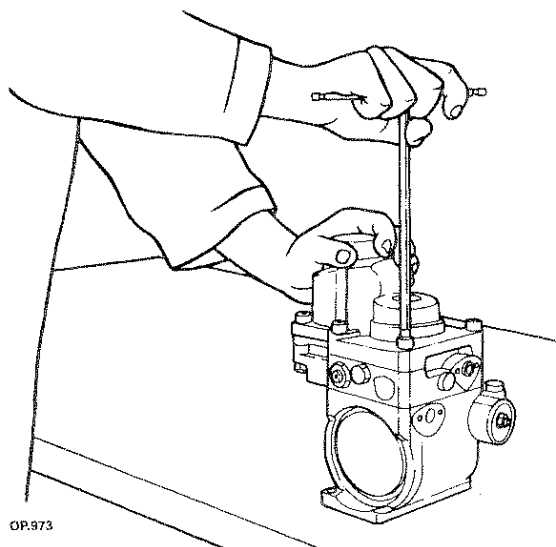

OP.973

4 - Place the vertical unit and loosen the screws.

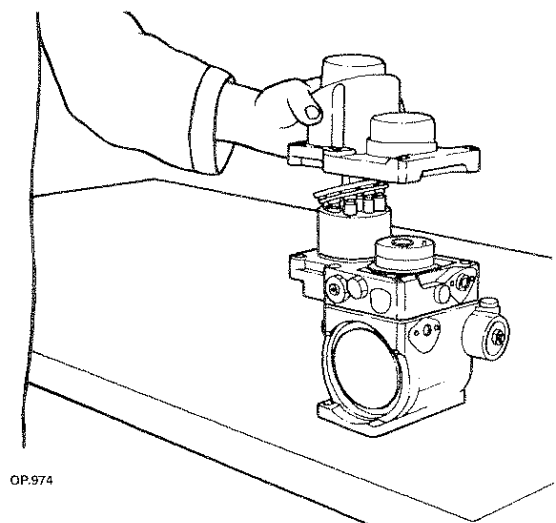

OP.974

5 - Remove the motor casing from the top and make sure that all the elements don't fall or get damaged.

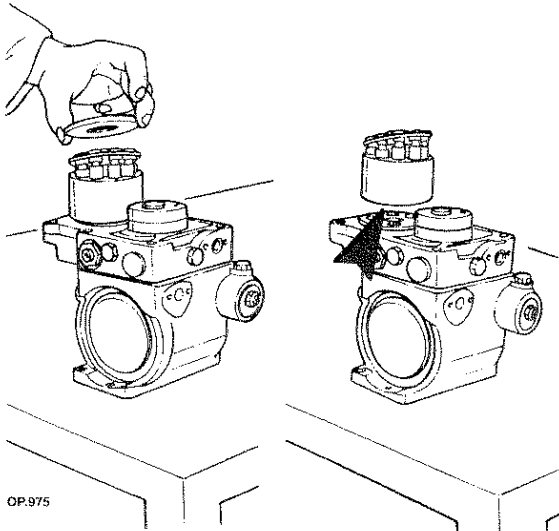

6 - Remove the inclined plate and the rotating unit of the engine resting it on a flat and clean surface.

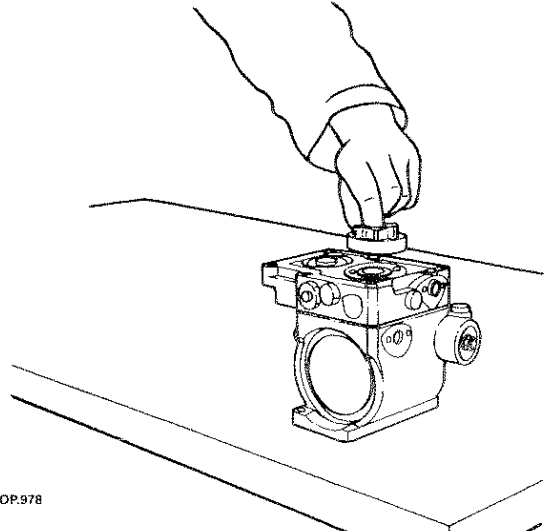

9 - Remove the rotors of the feed pump.

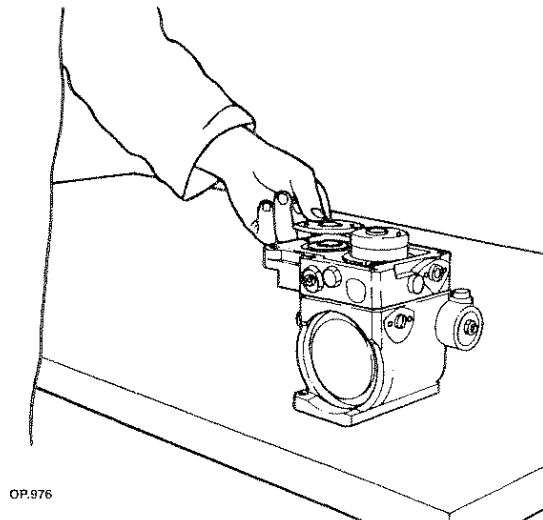

7 - Remove the distributor plate, clean it and rest it on a flat and clean surface.

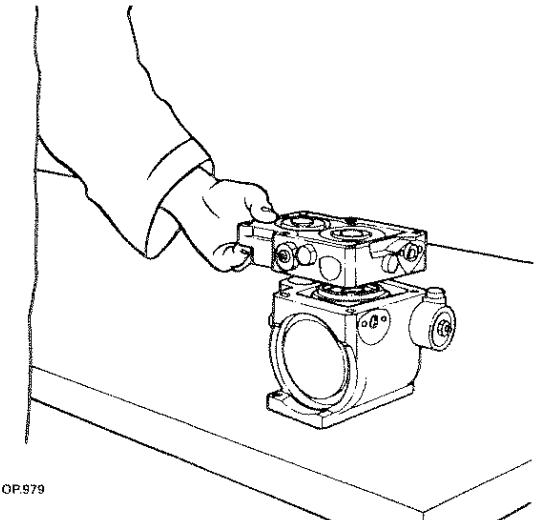

10 - Remove the distributor block and make sure that the plate of the rotating block does not remain attached.

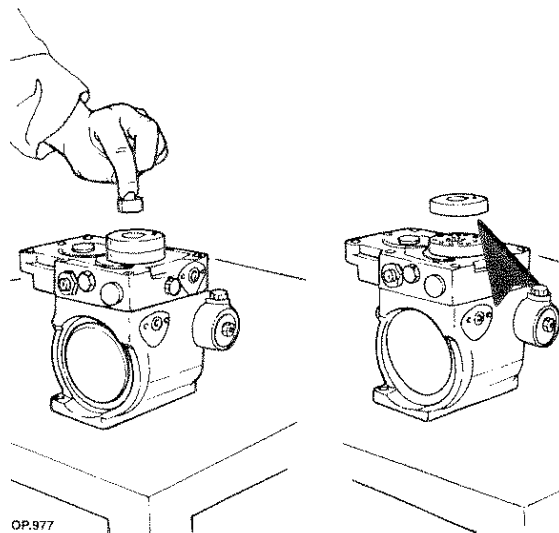

8 - Remove the spacer and the centring of the feed pump.

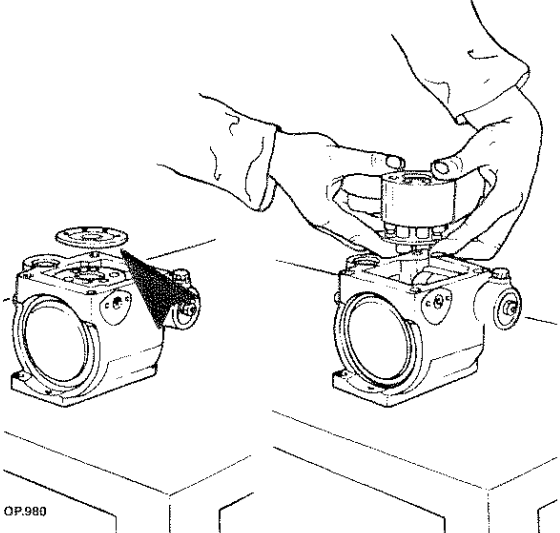

11 - Remove the plate and the whole rotating block.

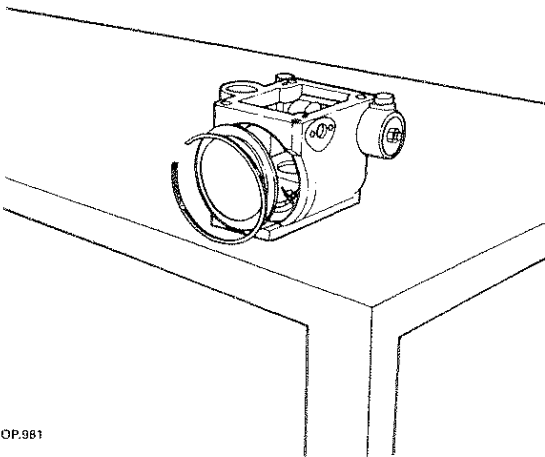

OP.981

12 - Remove the snap ring with the help of a screwdriver with flat tip and remove the cover.

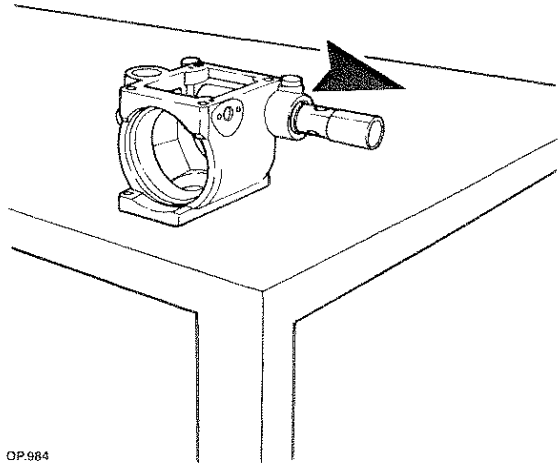

OP.984

15 - Withdraw the servocontrol cylinder.

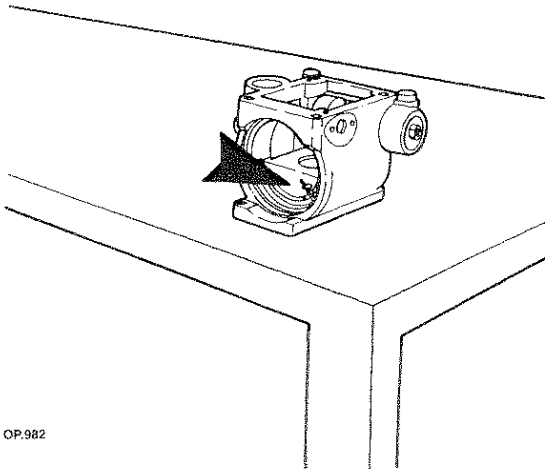

OP.982

13 - Remove the oscillator and pay attention not to damage the housing phase wires, remove the two semishells and relative centring pins.

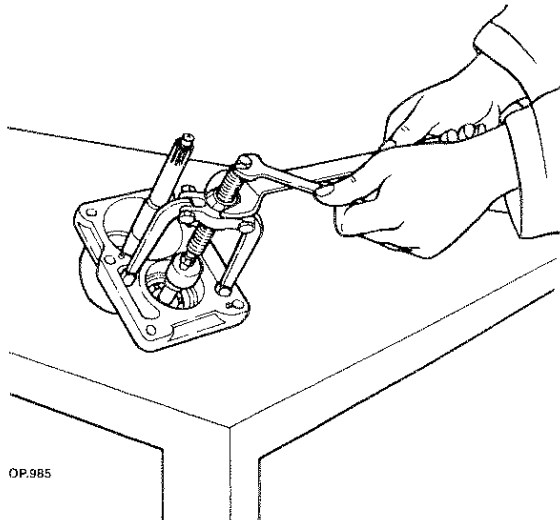

OP.985

16 - Remove the bearing using the extractor with jaws AT 37981216 and the adapter AT 37981222 - AT 37981222.

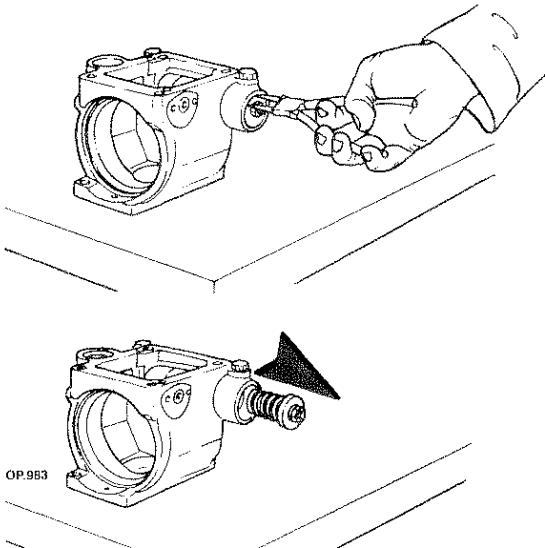

OP.983

14 - Remove the two seal rings and withdraw the two servocontrol adjustment units.

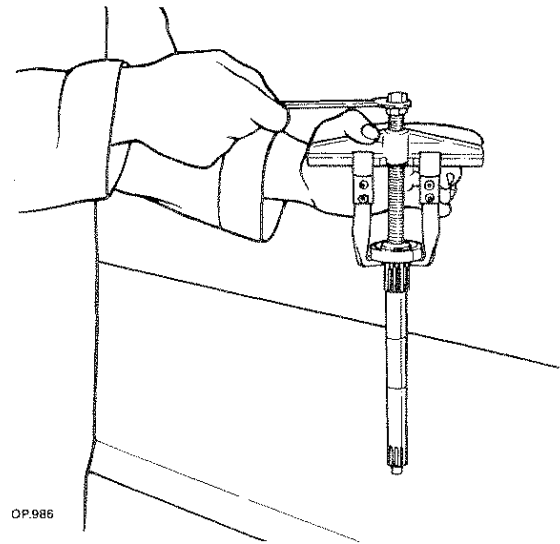

OP.986

17 - Remove the bearing with the universal puller AT 37981257.



Note - Warning

It is important to check thoroughly the different parts of the pump and of the engine, once the unit has been totally disassembled. Neat and orderly components guarantee a good efficiency and long life of the transmission. Worn out parts cause inefficient functioning and reduce power due to oil leaks inside the pump with consequent overheating of the oil and waste of fuel during running of machine.

CHECKING THE DISTRIBUTOR PLATE - THE PISTON CYLINDER BLOCK AND PADS

See drawing on page 58-59 no. 12-23-13-17.

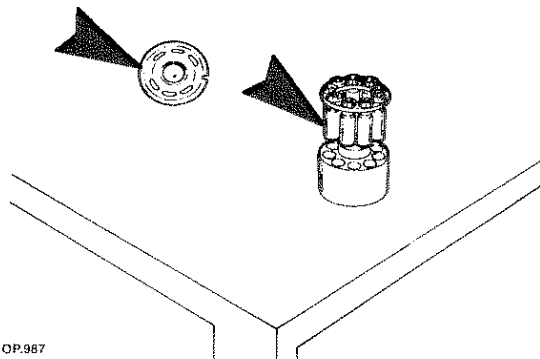

OP.987

The distributor plate is in stainless steel; scratches on the surfaces observed in the space between the two distribution slots are normally caused by solid and abrasive particles contained in the hydraulic fluid. Parts with badly scratched surfaces (you can feel with fingers) do not ensure effective tightness. These parts must either be lapped or replaced, depending on how badly they are worn out.

The surface of the cylinder block that rotates in contact with the distributor plate is submitted to the same considerations explained in the previous chapter. Moreover, the piston sliding bushings and backlash must also be carefully checked.

In case these parts are badly scratched or that they present excessive play, the whole block must be replaced.

Each piston ends with a spherical articulation that houses the sliding pad on the oscillator. Slid and abrasive particles cause scratching of the pad and the piston. Should the latter be badly scratched then they must be replaced, if they are not then they simply need to be ground.

CHECKING THE OSCILLATING SEMI-SPHERE PAD PRESSING DISC AND THE INCLINED PLATE

See drawing page 58 - 59 no. 18 - 21 - 36 - 22.

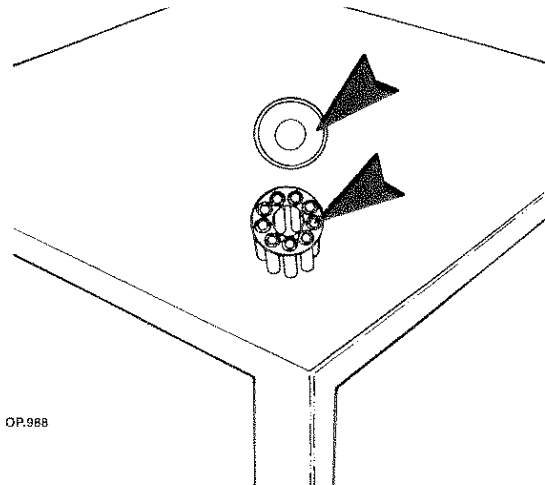

OP.988

Altering of the original colour of the plate pressing disc indicates that the unit has been working at extremely high temperatures and this may cause deformation and excessive wear of the rotating unit and of the oscillation semi-sphere.



The disc must however be replaced when on the area in contact with the pistons and in contact with the semi-sphere are felt with fingers ring-like scratches due to particles and wear.

The disc must also be replaced in case you feel, with finger nail, wear marks, such as scoring or seizing due to particles contained in oil, overheating or faulty hydrostatic sustentation of the pistons. Check that the sliding part of the oscillator on the roller housings is not damaged.

CHECKING DISTRIBUTOR BUSHING AND BEARING SHAFT

See drawing on page 58 - 59 no. 11 - 1 - 28 - 4.

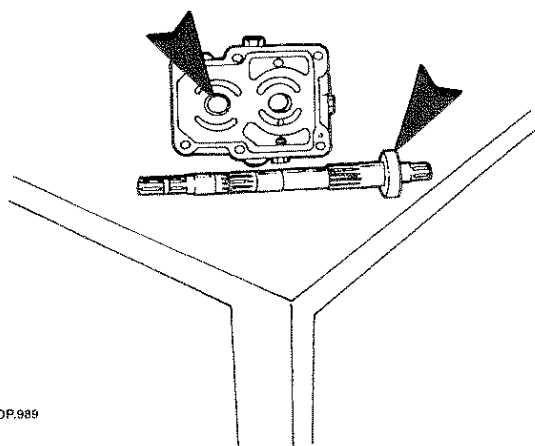

OP.989

Check that the bushing inside the distributor where the shafts rotate does not present wear marks on the anti-friction material, scoring or excessive play with the shaft.

Check that on the part of the shaft that slides inside the bushing there are no wear marks or scoring.

Check that the groove on the shaft that transmits the drive to the cylinder block is not worn out.

Check that the bearing rollers and relative tracks do not present obvious wear signs or scoring.

CHECKING THE SERVO-CONTROL

See drawing page 59.

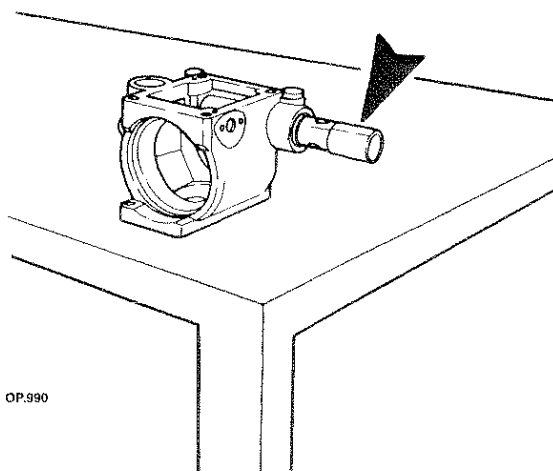

OP.990

Make sure that the piston does not present scratching that can be felt with finger nail; check that the seal areas of the servo-control body are not damaged and that the play between the servo-control and the piston is very limited but must still allow it to slide smoothly.

CHECKING THE BOOSTER PUMP

See drawing on page 58 - 59 no. 7-8-9

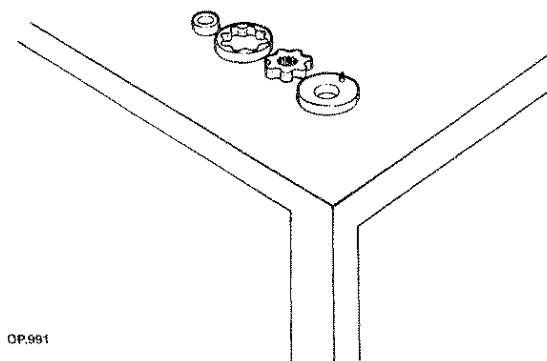

OP.991

The surfaces of the booster pump rotors must not be scratched; they must have a slight radial play (that is when one is inside the other) and minimum play between outer rotor and the body. Check with finger nail that there are no bad wear marks on the centring disc 7 and the sliding surface of the distributor.



CHECKING MAXIMUM PRESSURE VALVE

See drawing on page 59.

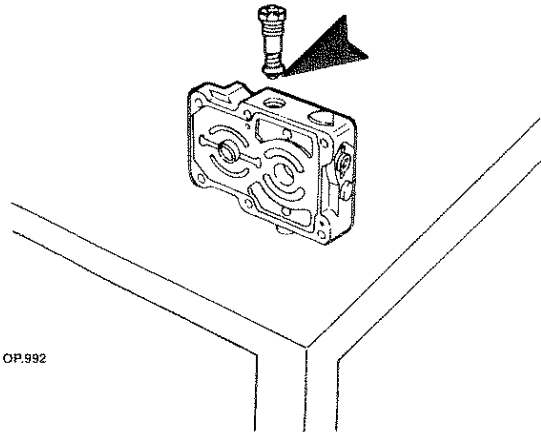

OP.992

The maximum pressure valve have a fixed factory setting that cannot be modified. The standard value is 300 bar. Make sure that there are no dents nor scratches on the inner seat of the distributor that may cause the blow-by inside the valve seat. Replace the distributor in case the housing of the seal is damaged.

CHECKING THE FEED VALVE

Se drawing page 58 - 59 no. 60-30-31-32-33.

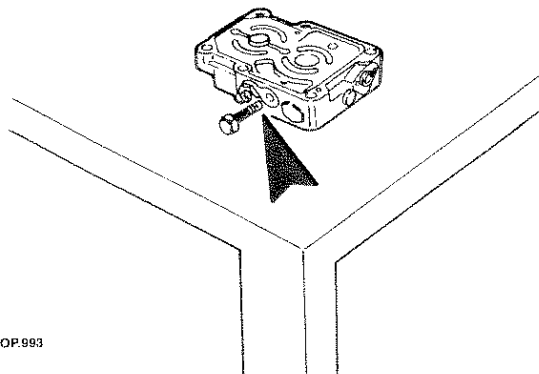

OP.993

Make sure that the cylindrical part of the shutter is not worn out and that it is not dented nor scratched and that the spring and other parts are not damaged nor deformed. If they are, then the whole valve should be replaced.

Check that the seal housing of the shutter on the distributor is not dented nor deformed. If the seat is worn out replace the distributor.



WARNING - DANGER



Perform operations by strictly observing accident prevention regulations.

- Use tools to align holes and slots not hands.

ASSEMBLY

Proceed to the assembly, bearing in mind the following instructions:

- a - proceed inversely as to the disassembly operations.
- b - observe the pictures page 58 - 59 for location of the different components
- c - observe driving torques listed at page 4
- d - bear in mind the following:

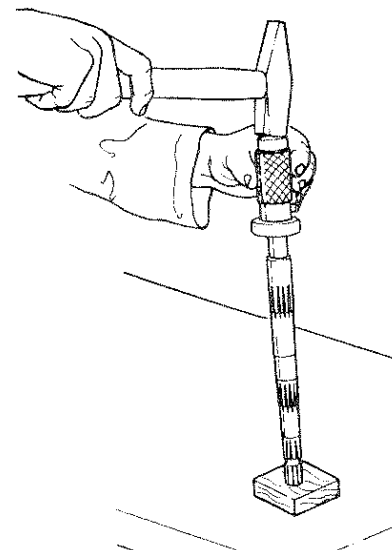

OP.994

1 - Mount the bearing on the pump shaft with driver AT 37981319.

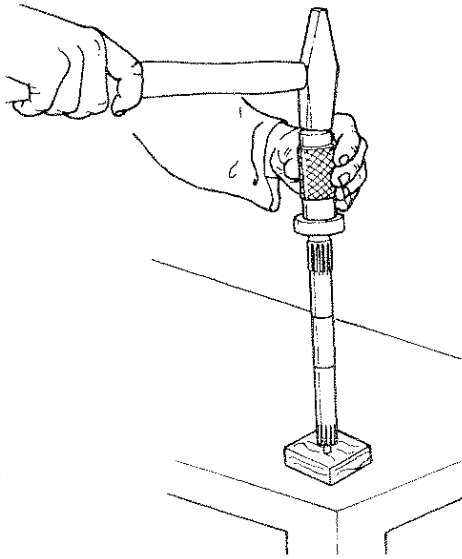

OP.995

2 - Mount the bearing on the engine shaft with driver AT 37981319.

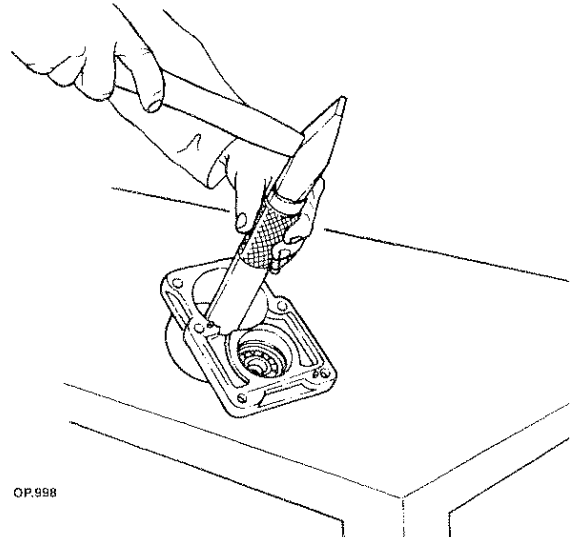

OP.998

5 - Mount the engine shaft along with bushing using driver AT 37981323.

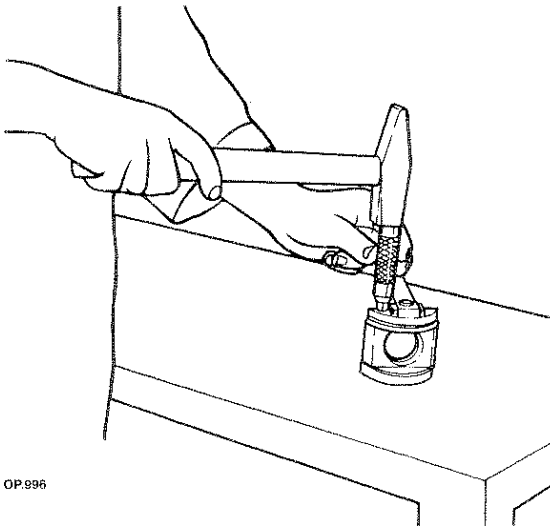

OP.996

3 - Mount the two slide bushings of the oscillator with the help of driver AT 37981320.

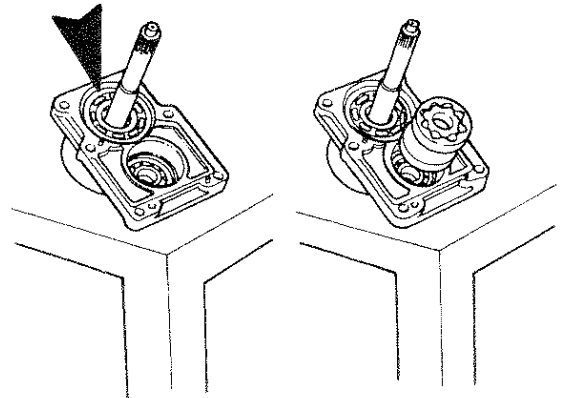

OP.999

6 - Insert the rotating unit of the engine and the feed pump unit.

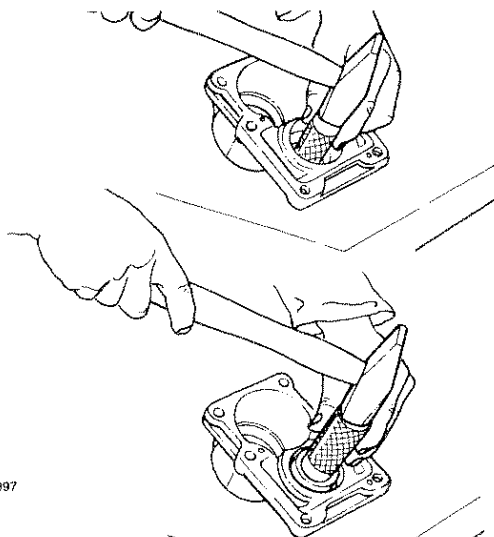

OP.997

4 - Mount the seal ring with driver AT 37981321 and the bearing with driver at37981322.

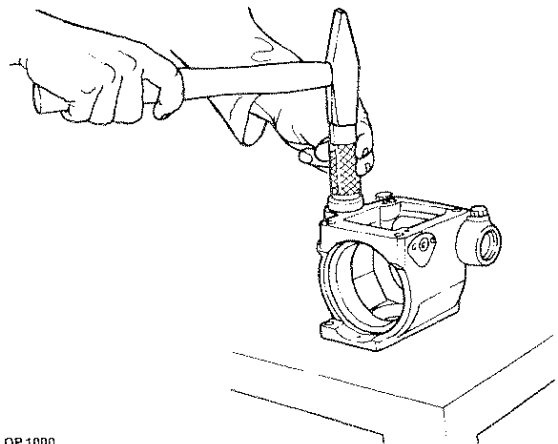

OP.1000

7 - Mount the seal ring with driver AT 37981324.

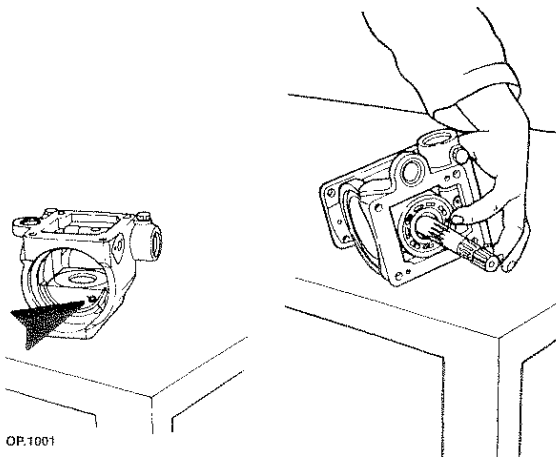

OP.1001

8 - Mount the whole oscillating unit, oil all oscillating surfaces thoroughly and insert the shaft and the whole rotating unit.

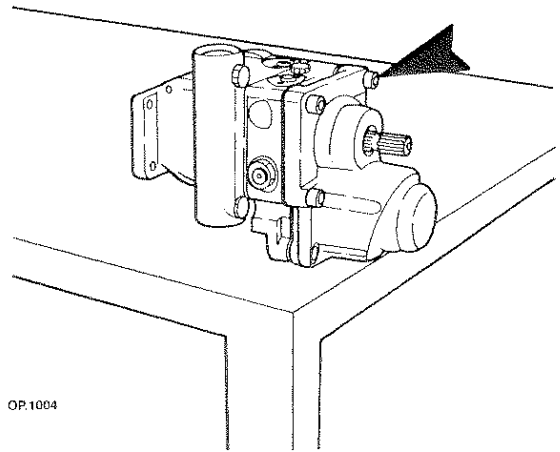

OP.1004

12 - Put the three units together and make all surfaces meet then fasten together by means of screws.

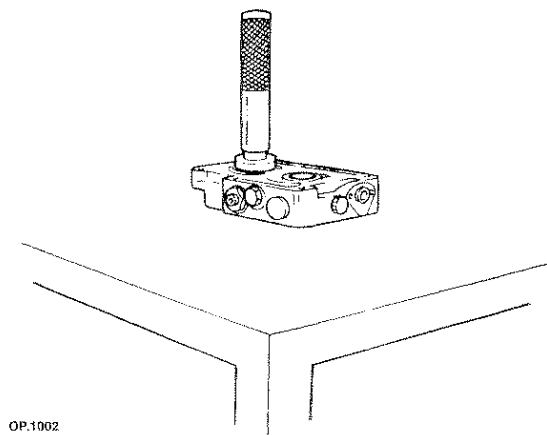

OP.1002

9 - Mount the bushing on the pump side as well as on the engine side with driver AT 37981325.

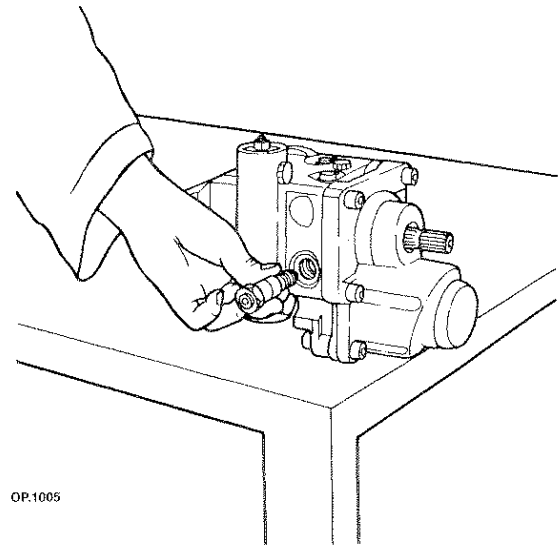

OP.1005

13 - Mount the maximum pressure valve.

14 - Insert a splined sleeve at the end of the pump shaft and test if it rotates freely.

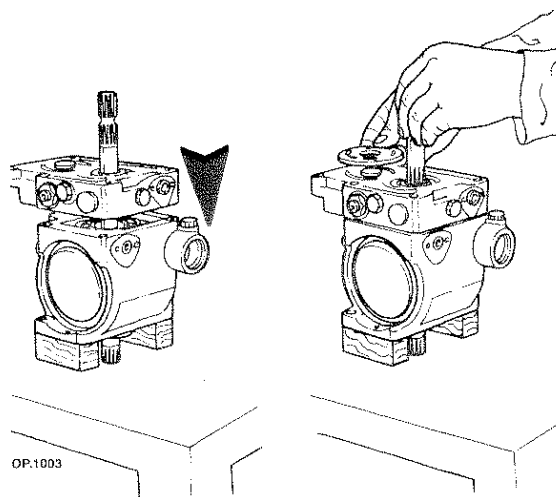

OP.1003

10 - Mount the O-rings on the intermediate distributor and insert it on the pump body.
11 - Mount and centre on both sides the pump and engine plates.



WARNING - DANGER



Perform operations by strictly observing accident prevention regulations.

- Do not use gasoline, diesel oil or other flammable liquids to degrease or clean parts but use commercial non-toxic solvents instead.



Hydrostatic unit

Troubleshooting

Trouble	Possible cause	Solution
With the control joystick (on the pedal) on zero position and the slow gear engaged the vehicle moves anyway.	<ul style="list-style-type: none"> - Remnant pressure in the control joystick. - Pump zero-setting not accurate. 	<ul style="list-style-type: none"> - Disconnect the joystick that controls the hydrostatic unit and check if movement persists. Repair or replace the joystick. - Set pump zero-setting again.
The oil in the hydrostatic system tends to overheat during normal running of the vehicle.	<ul style="list-style-type: none"> - Low oil level in tank. - Heat exchanger clogged or faulty. - Clogged suction filter or difficulty in the suction. - Excessive work load. 	<ul style="list-style-type: none"> - Check the oil level and top up if necessary. - Clean the radiant surface of the heat exchanger and make sure that fan operates properly. - Check the suction filter and replace it if necessary. - Reduce work load.
<ul style="list-style-type: none"> - The vehicle doesn't move regularly. - The vehicle jerks. - Poor hauling force of the vehicle. 	<ul style="list-style-type: none"> - Low oil level in tank. - Clogged suction filter or difficulty in the suction. - Low boosting pressure. - Clogged maximum level valve. 	<ul style="list-style-type: none"> - Check oil level and top up if necessary. - Check the suction filter and replace it if necessary. - Check boosting pressure. - Check and clean valve.
<ul style="list-style-type: none"> - The vehicle moves regularly forward and back only. - The vehicle doesn't move at all even when servo-control is actuated. 	<ul style="list-style-type: none"> - Faulty servo-control. - Clogged maximum valve on one or both sides. - Low oil level in the tank. - Clogged suction filter or difficulty in the suction. - High oil temperature. - Low boosting pressure. - Wear of components. 	<ul style="list-style-type: none"> - Exchange tubes from servo-control and check if trouble persists in the same direction. If otherwise, replace or repair the servo-control. - Check oil level in tank and top up if necessary. - Check the suction filter and replace it if necessary. - Check boosting pressure. - Check and clean valve. - Check performance of unit and if necessary replace and overhaul the whole unit.



CHECKING PRESSURES OF HYDROSTATIC UNIT

Check boosting pressure.

To check the boosting pressure of the pump, proceed as follows:

- 1 - Switch off the diesel engine and install a pressure gauge on the boosting pressure coupling AT 37981190 and adapter AT 37981259.

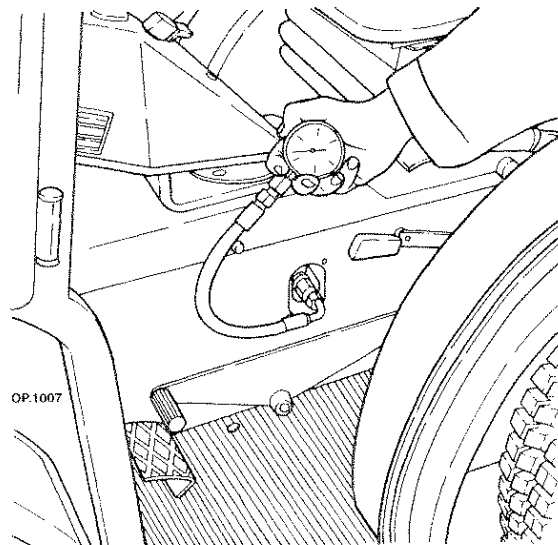
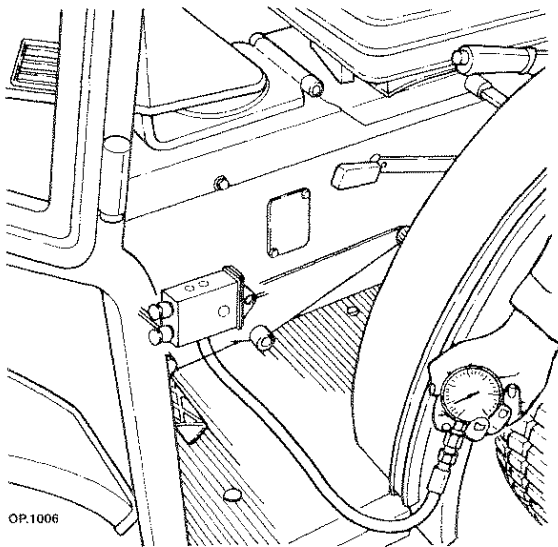

- 2 - Start diesel engine and let it run at a speed of 2500 rpm with pump and zero engine power. With oil temperature at 50°, check that feed pressure is at 25 bar about.

Checking the maximum level valve.

To check the pressure of the maximum level valve, proceed as follows:

- 1 - Switch off the diesel engine and install a pressure gauge on the boosting pressure couplings AT 37981190 and adapter AT 37981259 available on the plugs of the maximum level valve.

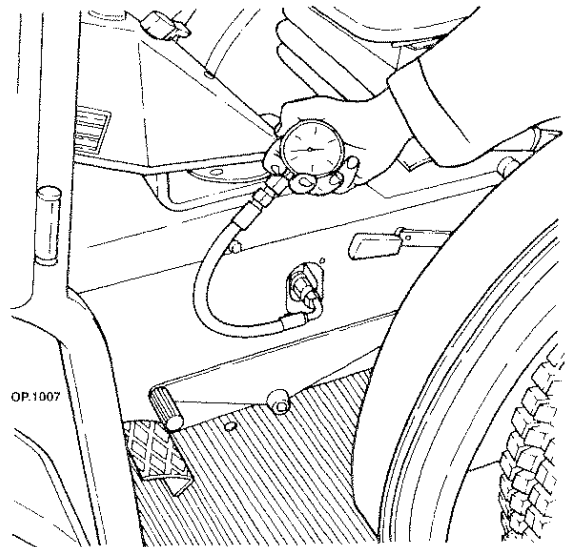

- 2 - Start diesel engine and let it run at a speed of 2500 rpm with pump and zero engine power with oil temperature at 50°.

- 3 - Brake suddenly but make sure that there are no obstacles nor people in front or behind vehicle.

- 4 - Engage the high speed gear and actuate the pump until you hear the release of the maximum level valves (the typical noise of this operation clearly indicates that the valves have opened).

Maximum peak pressure 300 bar.

- 5 - Testing should be done fairly quickly to prevent overheating the oil.



WARNING - DANGER



Perform operations by strictly observing accident prevention regulations.

- Watch out for projection of fluids at high pressure.

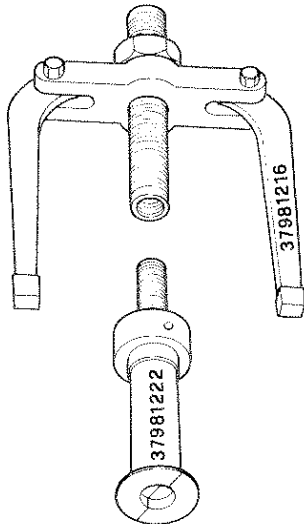

AT.001

1 - Combined puller to extract bearings.

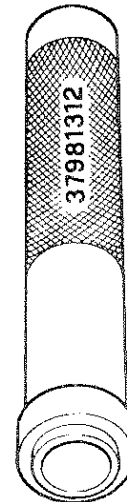

AT.205

4 - Driver for mounting and removing the roller casing of the central plate of the Super-park.

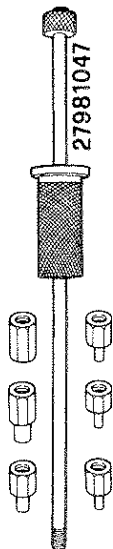

AT.004

2 - Puller and adapter

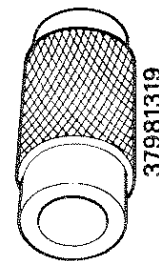

AT.206

5 - Driver for assembly of bearings of hydrostatic unit.

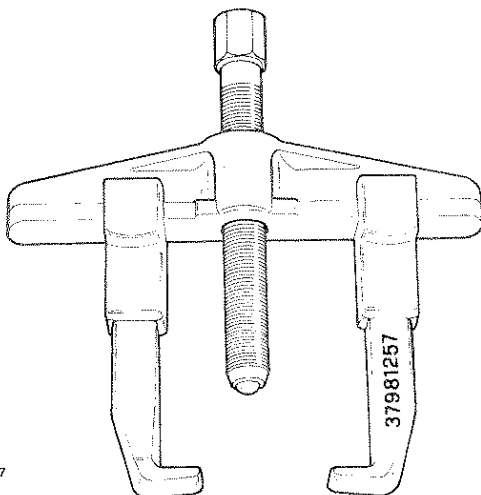

AT.067

3 - Universal puller

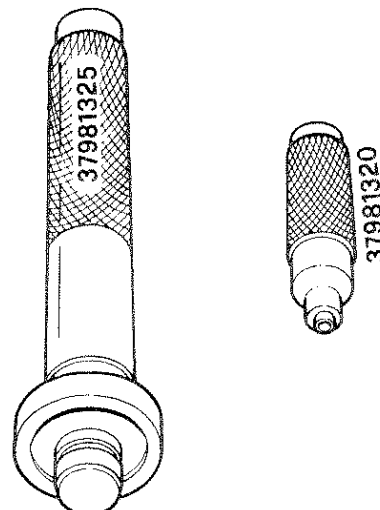

AT.207

6 - Driver for assembly of bushings on the hydrostatic unit.

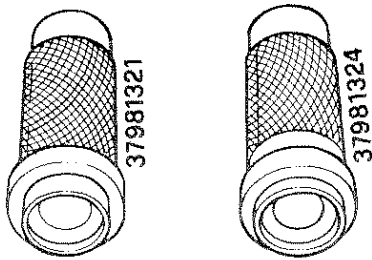

AT.208

7 - Drivers for the assembly of seal packings on the hydrostatic unit.

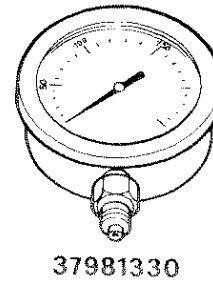

AT.211

10 - Pressure gauge from 0-600 bar. Pressure measurer.

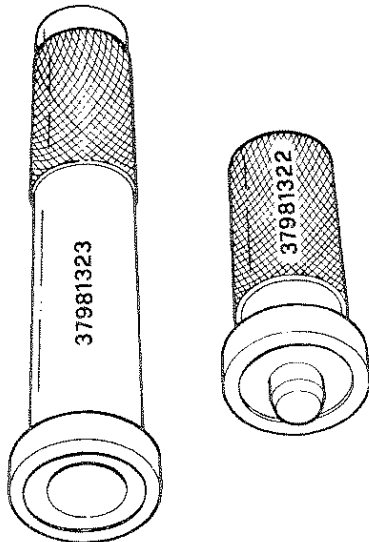

AT.209

8 - Drivers for the assembly of the bearings on the hydrostatic unit.

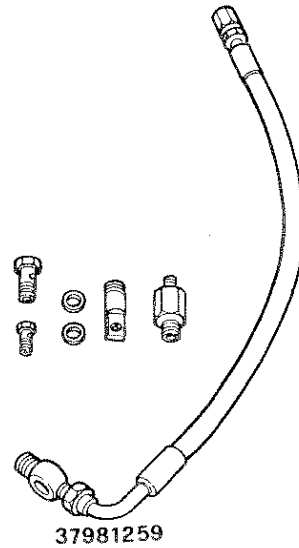

AT.061

11 - Adapter for measuring pressure.

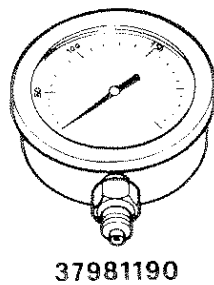

AT.210

9 - Pressure gauge from 0-100 bar pressure measurer



SPEED CHANGE ASSEMBLY

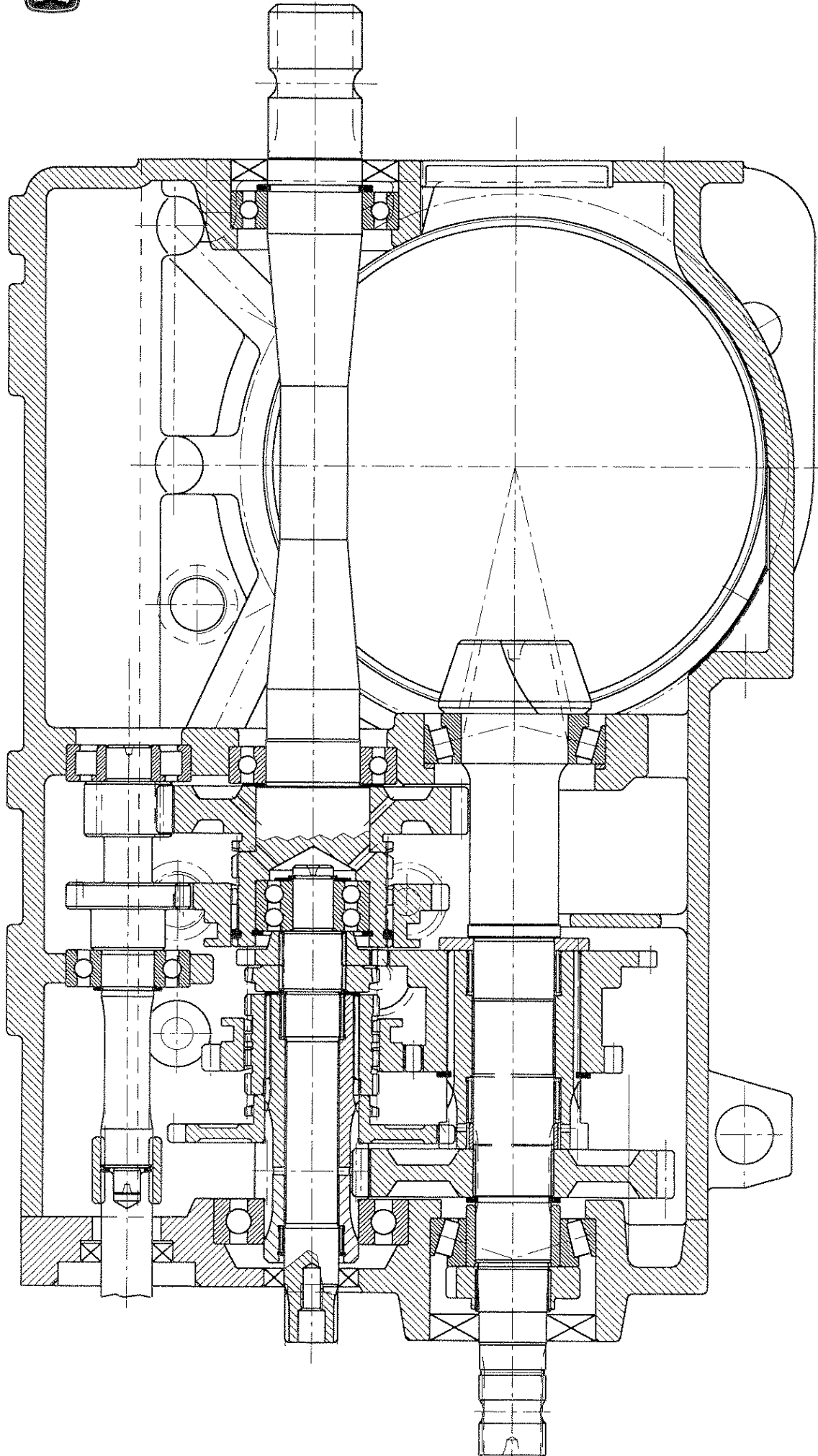



TIGRETRAC REAR TRANSMISSION

SUPERPARK REAR TRANSMISSION

Disconnecting - connecting instructions

Tigretrac - Superpark

To have access to the rear transmission unit (speed change) you need to:

1 - Proceed similarly as to the description regarding the disconnecting and connection of the central transmission.

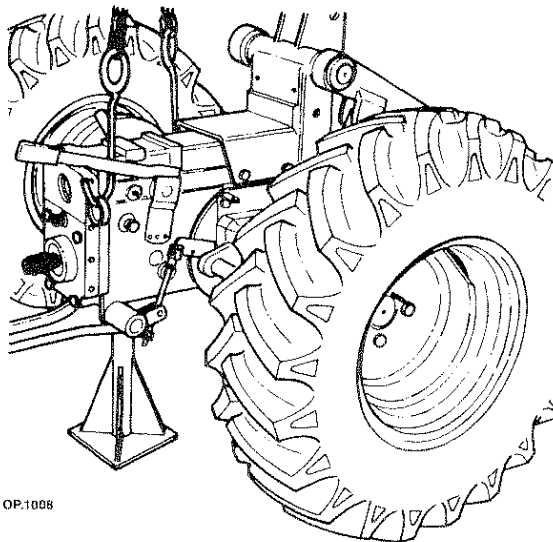

OP.1008

2 - Hook a rope to the hoist and fasten it to the speed change gearbox.

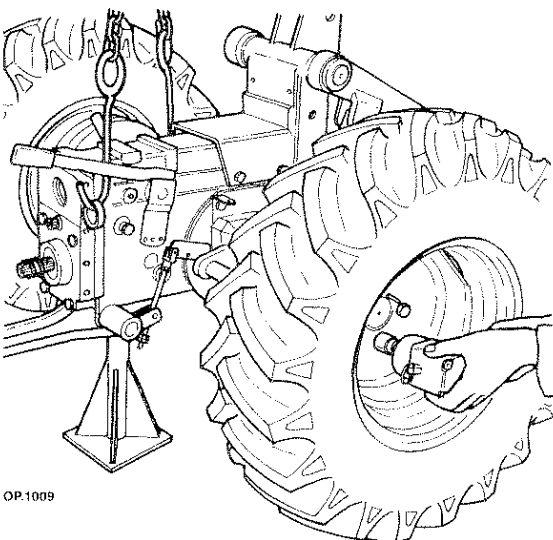

OP.1009

3 - Loosen the screws and remove wheels.

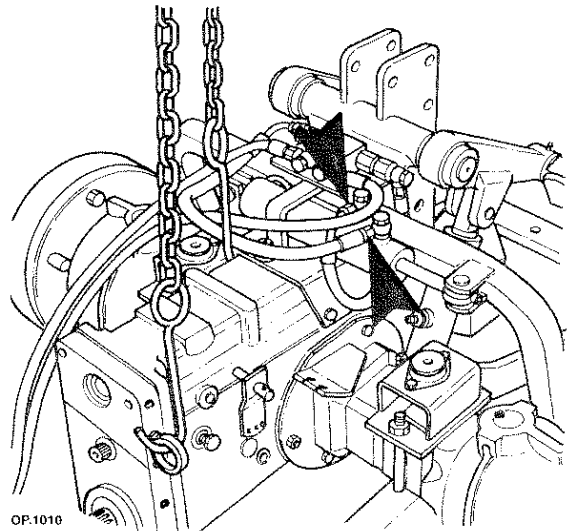

OP.1010

4 - Loosen the steering cylinder tube unions, loosen the screws and remove the valve and the steering valve support.

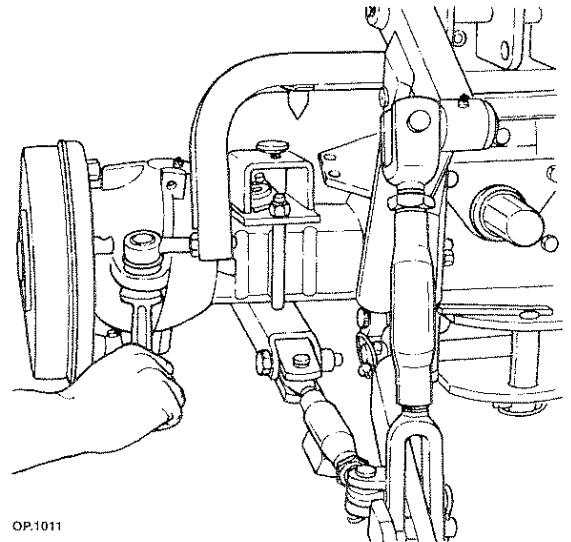

OP.1011

5 - Loosen the nuts on both ends of the steering coupling bar.

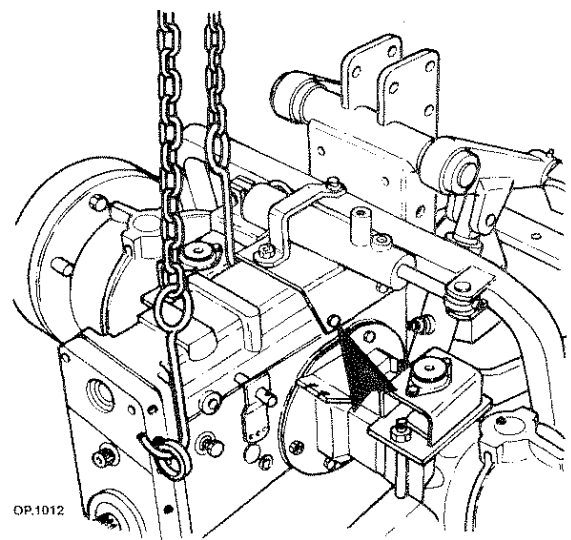

OP.1012

6 - Loosen the screws and remove the steering cylinder support and the coupling bar.

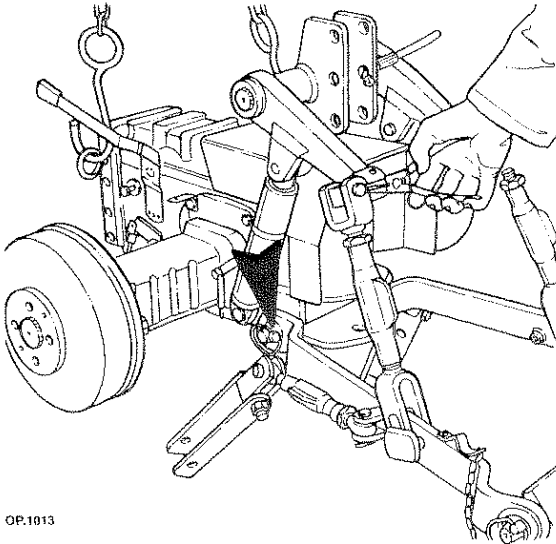

OP.1013

7 - Disconnect the tie-rods of the hoisting arms and remove the hoisting bars.

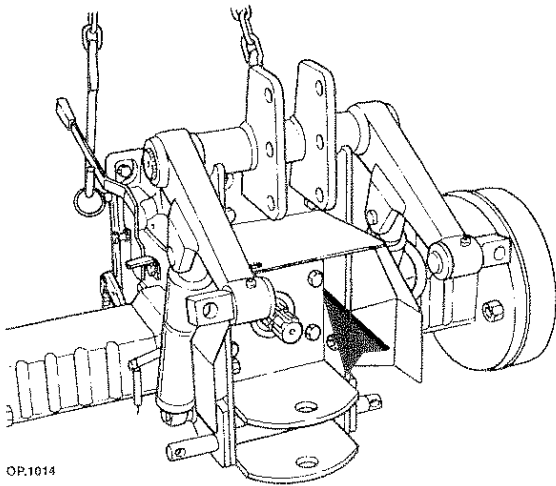

OP.1014

8 - Loosen the screws and remove the upper hoisting cover.

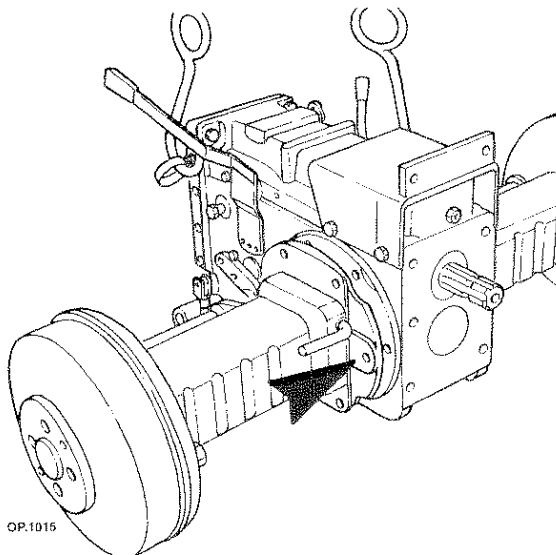

OP.1015

9 - Loosen the screws and remove the axles.



WARNING - DANGER



Perform operations by strictly observing accident prevention regulations.

- Use tools to align holes and slots not hands.

Connecting

Proceed to the connection, bearing in mind the following instructions:

a - reverse the disconnection operations.

b - follow the pictures for location of the different components.

c - observe the driving torque listed at page 4.

d - before inserting the extensions or the universal joints, accurately grease the grooved contours (regarding the type of grease to use refer to page 5).

e - tighten the anchoring dowels of the extensions or the joints with the help of Loctite 242 (average strong thread lock).

f - clean carefully, especially the surfaces to be mated. Apply a 3 mm string of gasket forming compound following the path indicated in the figure:

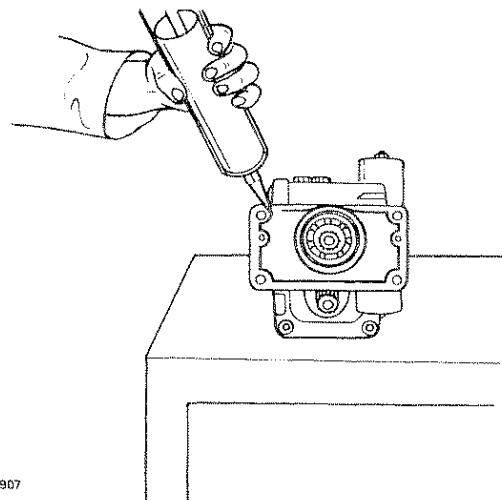

OP.907

Application diagram of gasket forming compound

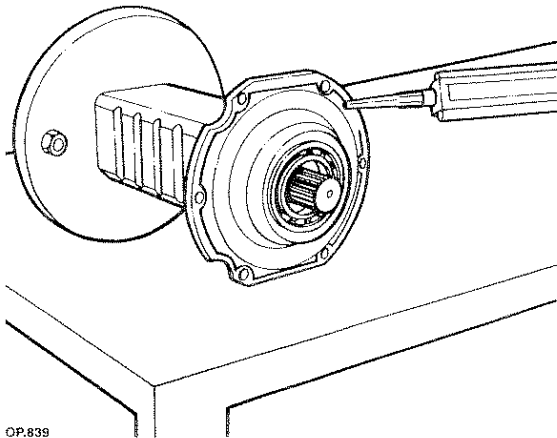

OP.839

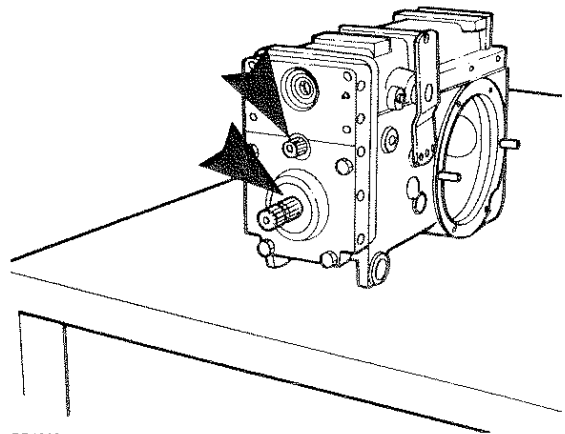

OP.1016

2 - Remove the seal ring.

g - clean all parts that will be in contact with the hydraulic oil of the circuit thoroughly (tank - tubes - heat exchanger).

h - make sure that there are no obstacles that hinder the regular suction of the pump of the hydrostatic unit (stoppers).

i - replace the oil filter cartridge.

l - do not start engine and start the hydrostatic unit before having filled the hydraulic circuit with oil (new).

m - fill the tank (speed gear) with oil, see page 5.

n - fill the hydrostatic unit with oil, see page 5, through one of the drain holes.



WARNING - DANGER



Perform operations by strictly observing accident prevention regulations.

- Do not use gasoline, diesel oil or other flammable liquids to degrease or clean parts but use commercial non-toxic solvents instead.

Keep environment clean. Dispose of waste fluids, used filter cartridges, oils, lubricants and grease cleaners in the most suitable way and in compliance with regulations in force.

The collection of waste oils must be performed by authorized plants.

SPEED CHANGE GEAR

Disassembly - Assembly

To disassemble the different parts of the speed change gear, proceed as follows:

1 - clamp the transmission box on a threstle or on a work bench.

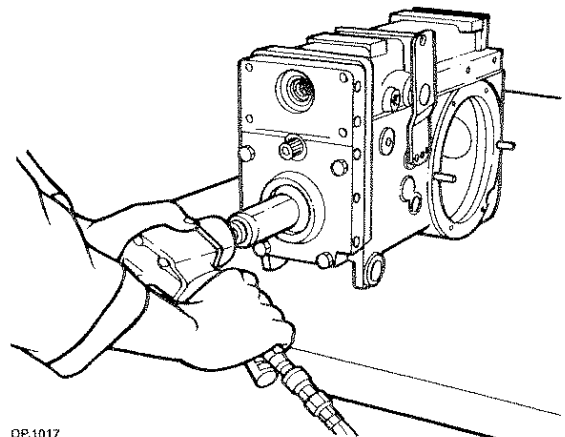

OP.1017

3 - Loosen the ring nut of the pinion with the help of tool AT 37981280.

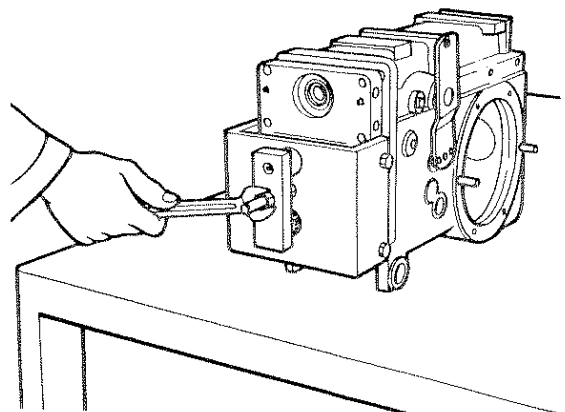

OP.1018

4 - Loosen the screws and using the puller AT 27981286 remove the gear change cover.

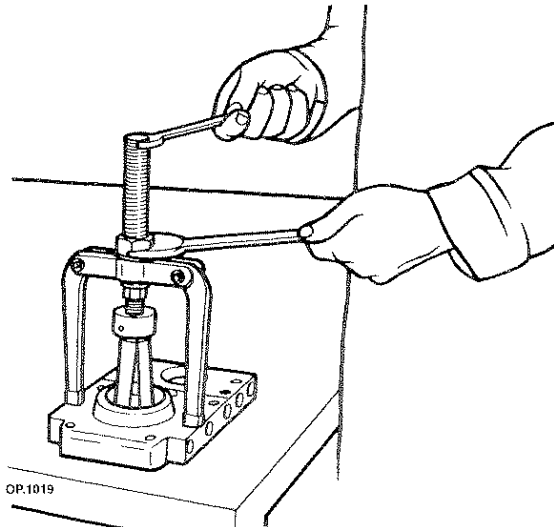

OP.1019

5 - Remove the seat of the rear pinion bearing with puller AT 37981216 and adapter AT 37981222.

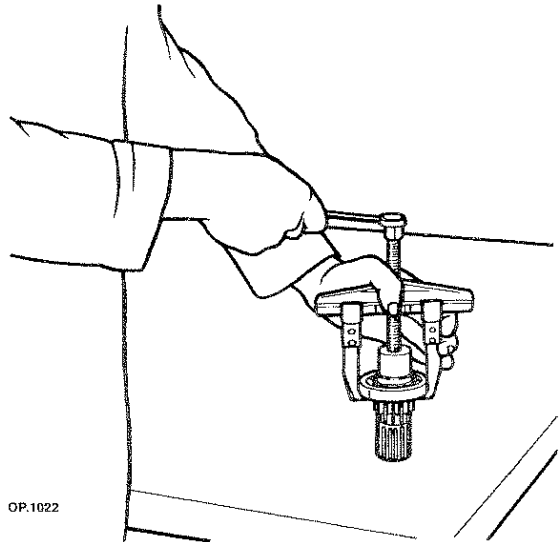

OP.1022

8 - Remove the bearing from the shaft with the help of adapter AT 37981257 and adapter AT 37981265.

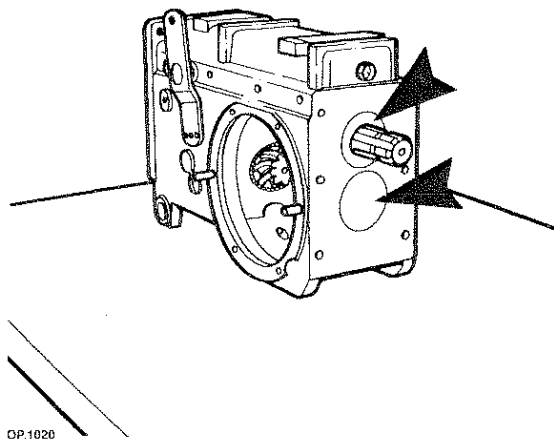

OP.1020

6 - Remove the seal ring of the PTO and the plug.

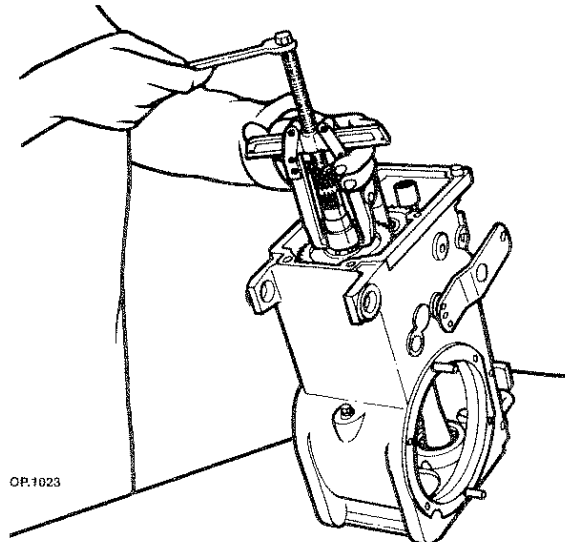

OP.1023

9 - Remove the reduction gear with the help of the universal puller AT 37981257.

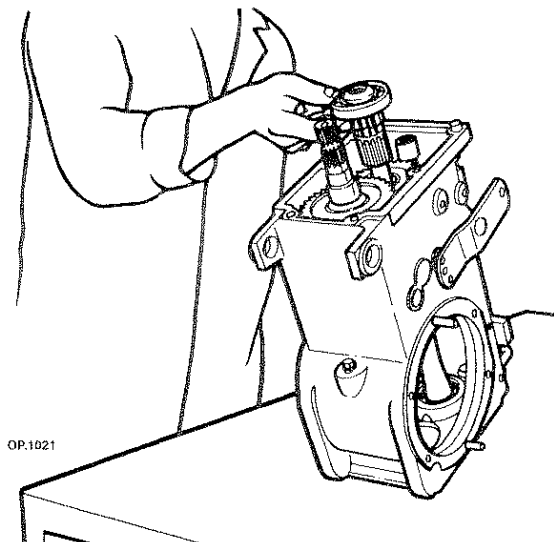

OP.1021

7 - Remove the drive gear shaft of the final reduction gear.

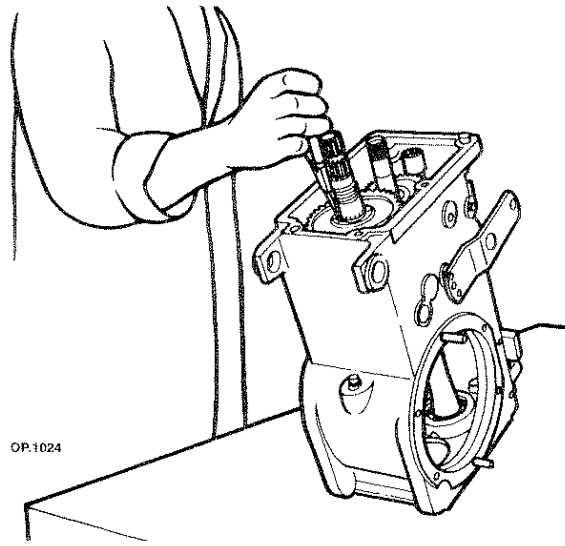

OP.1024

10 - Remove the spring retainer ring and remove the drive gear of the final reduction gear.

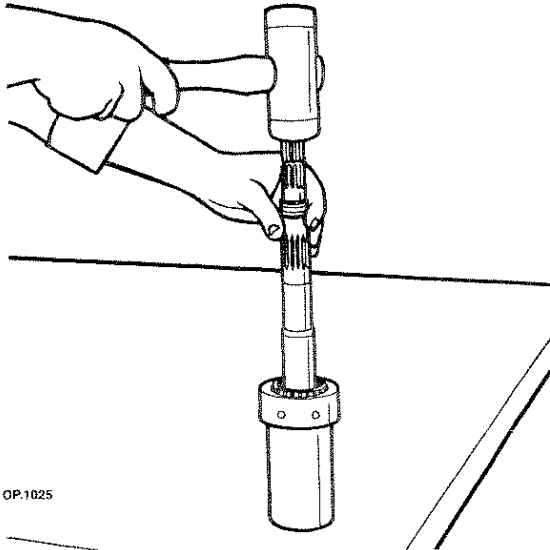

OP.1025

11 - Remove the pinion and remove the bearing with driver AT 27981287.

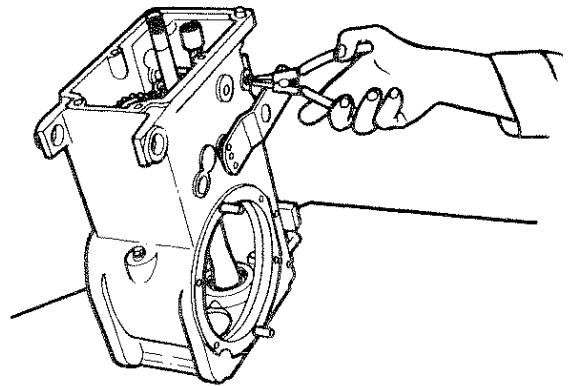

OP.1028

14 - Remove the spring retainer ring and remove the control shaft for the selection of the speed along with the spring pads and positioning sphere.

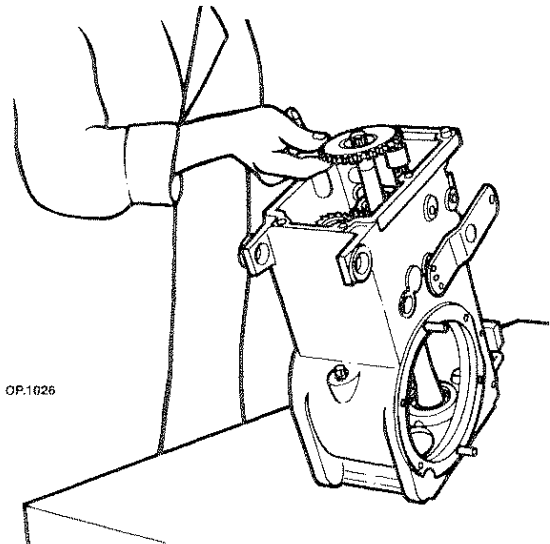

OP.1026

12 - Remove the slow gear.

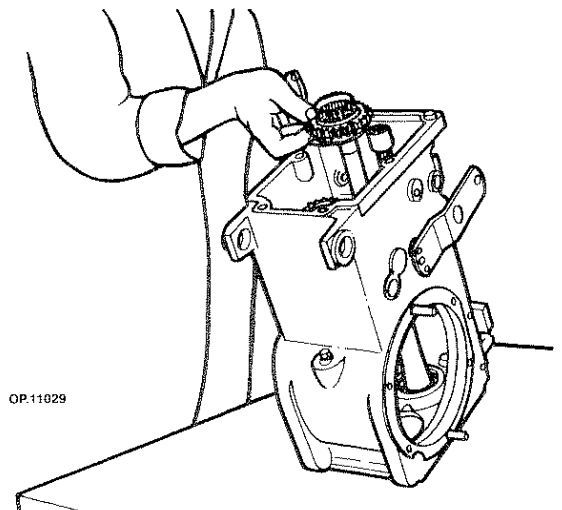

OP.11029

15 - Remove the fast-slow-regular speed engagement sleeve gear.

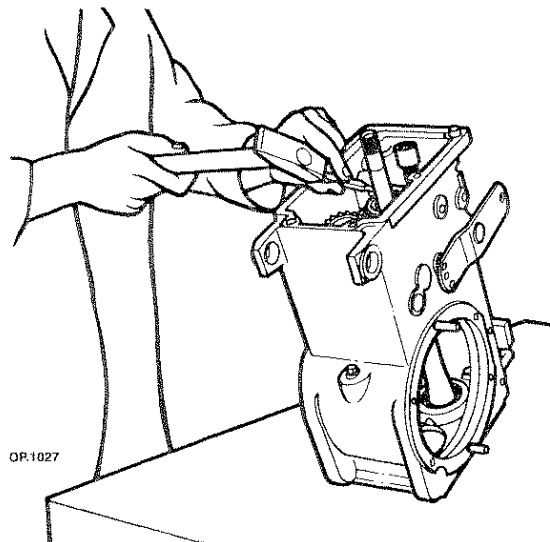

OP.1027

13 - Remove the spring pin from the speed engagement fork.

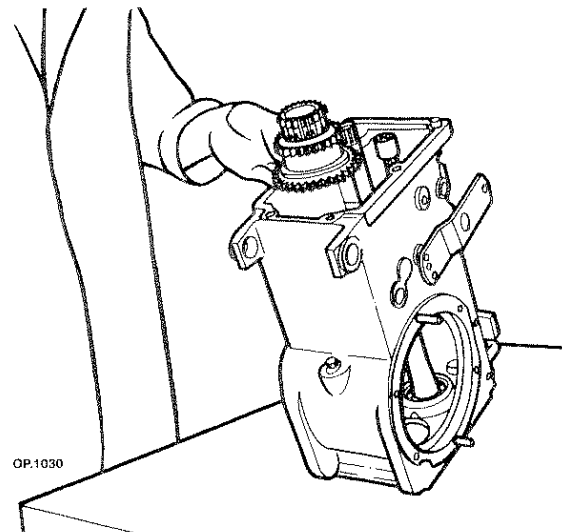

OP.1030

16 - Remove the L.N.V. driven unit along with the roller housings, spacers and shims.

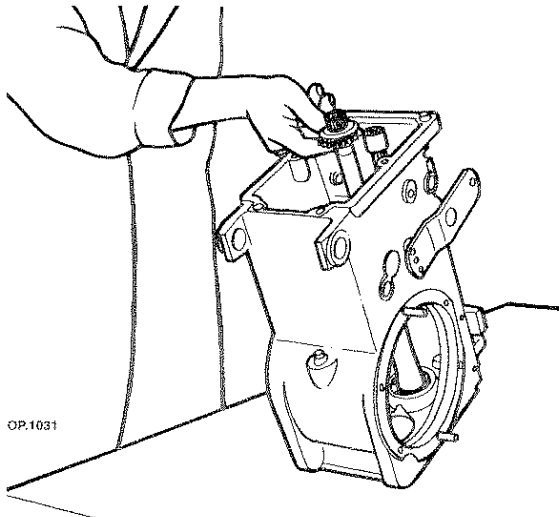

OP.1031

17 - Remove the roller housing on the drive shaft, the AS shims, the drive sleeve and the Fast speed drive gear.

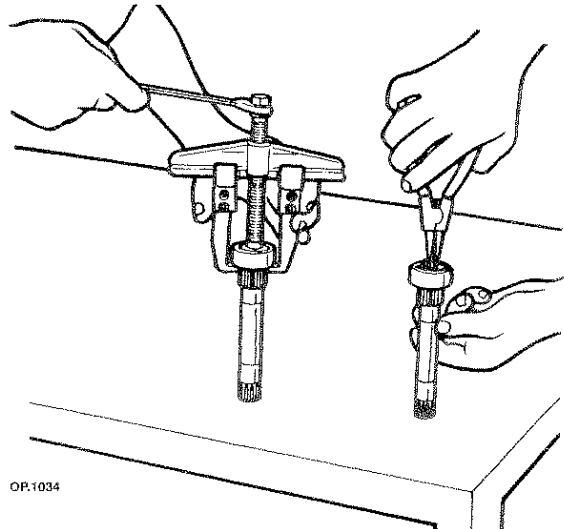

OP.1034

20 - Remove the retainer ring and remove the bearing using the puller AT 37981257.

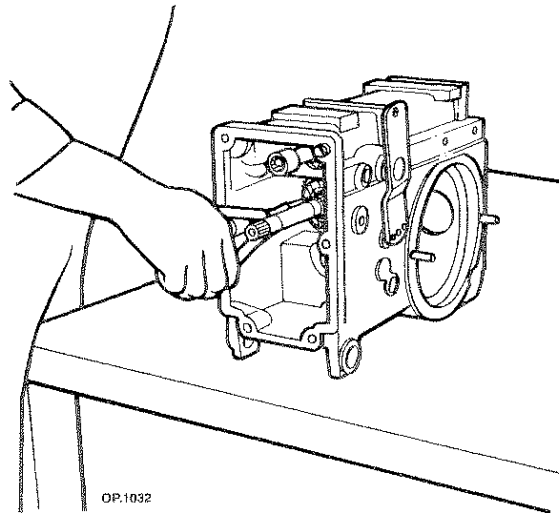

OP.1032

18 - Remove the retainer ring on the PTO shaft.

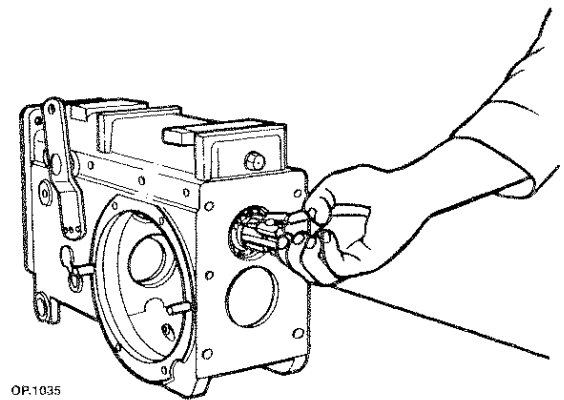

OP.1035

21 - Remove the retainer ring of the PTO shaft bearing.

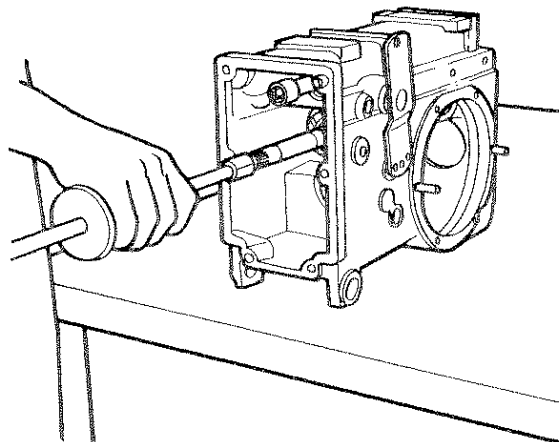

OP.1033

19 - Remove the main shaft with puller AT 27981047 and the adapter.

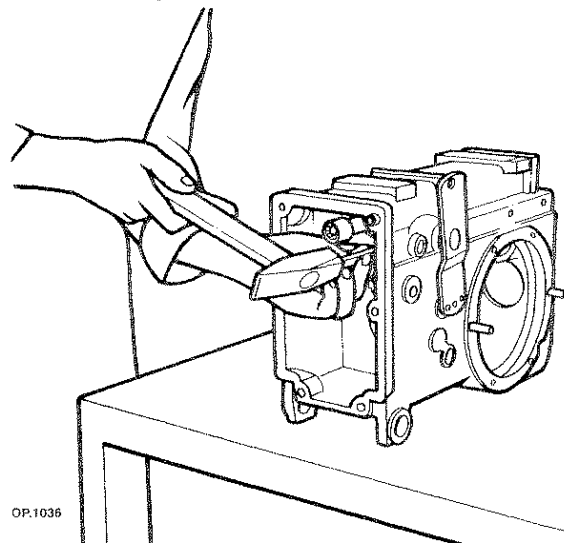

OP.1036

22 - Remove the spring pin and remove the PTO selection shaft.

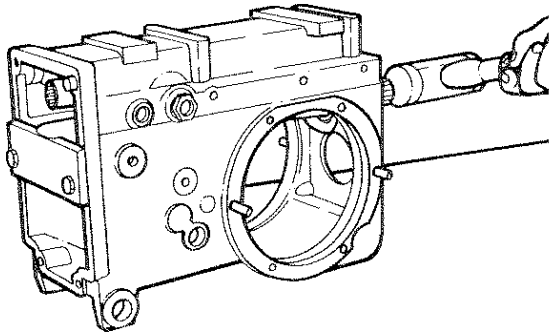

OP.1037

23 - Place the PTO gear retainer tool AT 37981302 and with the help of a mallet remove the PTO shaft.

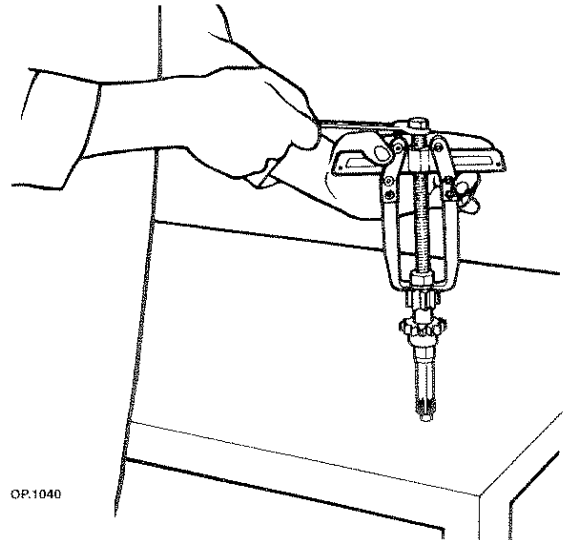

OP.1040

26 - With the help of puller AT 37981257, remove the seat of the bearing.

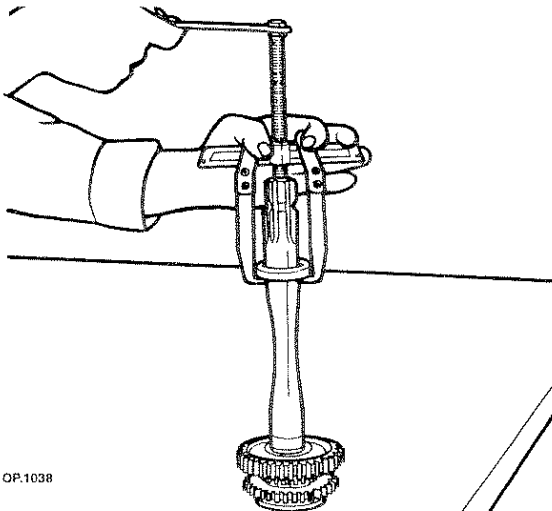

OP.1038

24 - Remove the bearing from the PTO shaft using the universal puller AT 37981257.

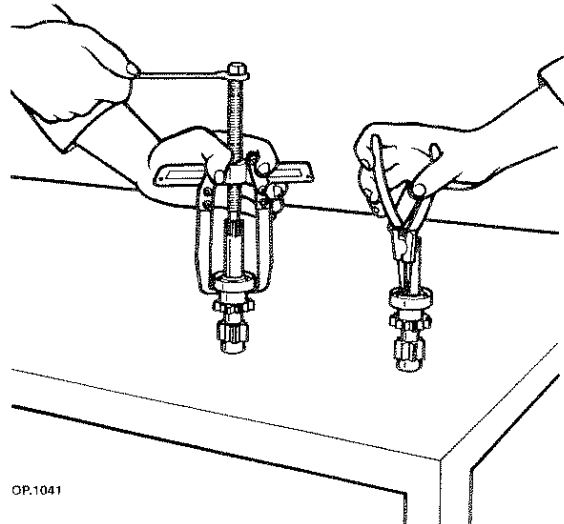

OP.1041

27 - Remove the retainer ring and remove the bearing with puller AT 37981257.

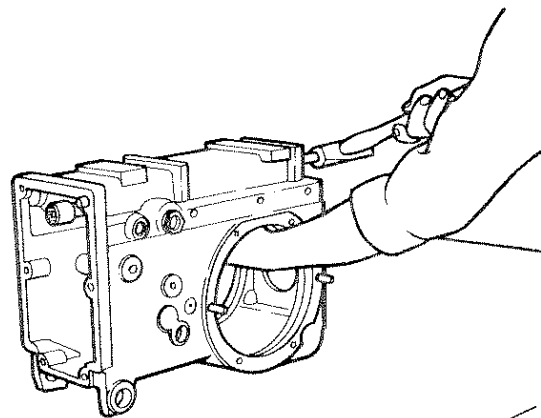

OP.1039

25 - Loosen and remove the oil filler cap of the change gear and with the help of a pin remove the PTO main shaft.

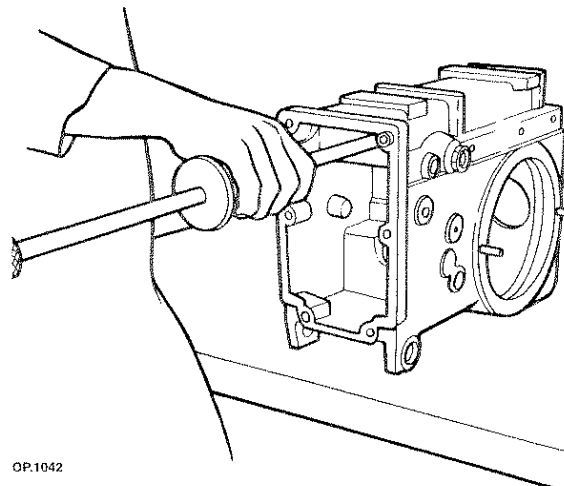

OP.1042

28 - With the help of puller AT 27981047 and adapter AT37981297, remove the bearing housing.

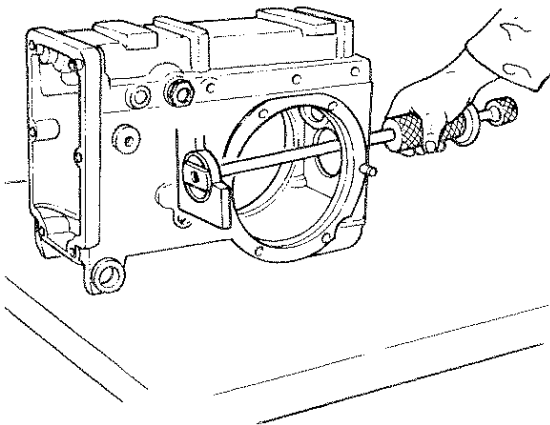

OP.1043

29 - With the help of a puller AT 27981047 and adapter at 37981296, remove the housing of the pinion bearing.



WARNING - DANGER



Operations that require special care may be hazardous for the operator if not correctly performed.

Spring pins:

When mounting the spring pins, make sure that the groove of the spring pins is oriented towards the stress point so that spring is under strain.

Spiral spring pins instead, do not require any orientation.

ASSEMBLY

Proceed to the assembly, bearing in mind the following instructions:

- a - proceed inversely as to the disassembly operations mentioned beforehand.
- b - follow the pictures for location of the different components.
- c - observe the driving torque listed at page 4.
- d - oil and grease the O-rings and seal packings.
- e - clean and accurately degrease the surfaces to be mated and apply a 3 mm string of gasket forming compound following the path indicated in the figure:
- f - Follow the operations below:

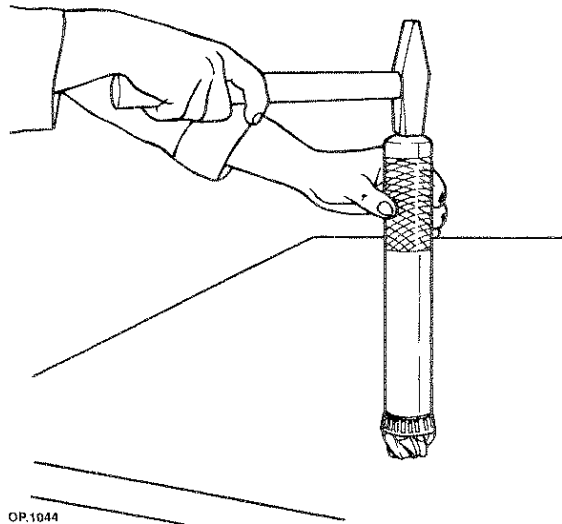

OP.1044

- 1 - Mount the bearing on the pinion shaft with driver AT 37981145.

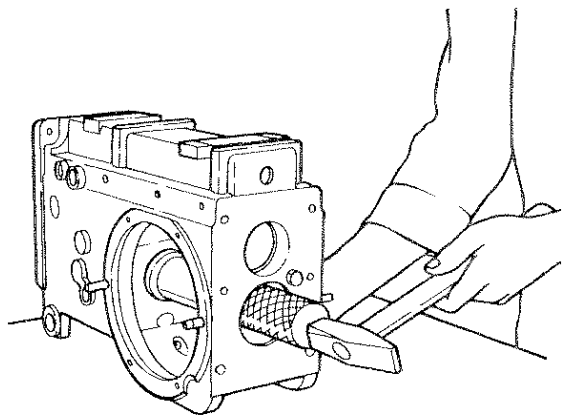

OP.1045

- 2 - Mount the bearing housing and relative shim using the driver AT 37981095.

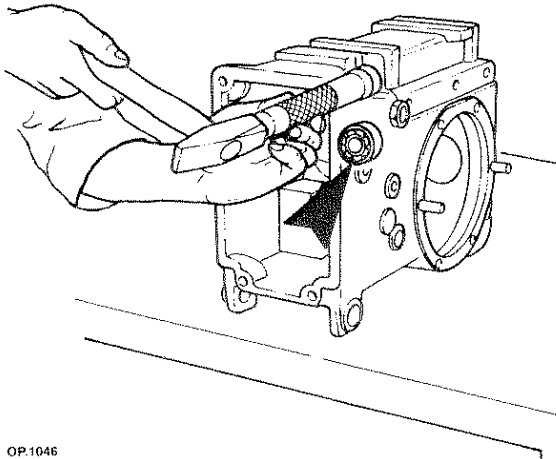

OP.1046

3 - Mount the bearings of the PTO shafts with driver AT 37981276.

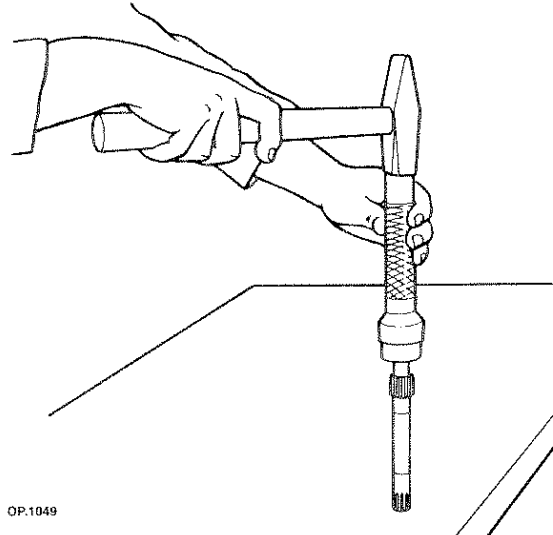

OP.1049

6 - Mount the bearing on the main shaft using driver AT 37981276.

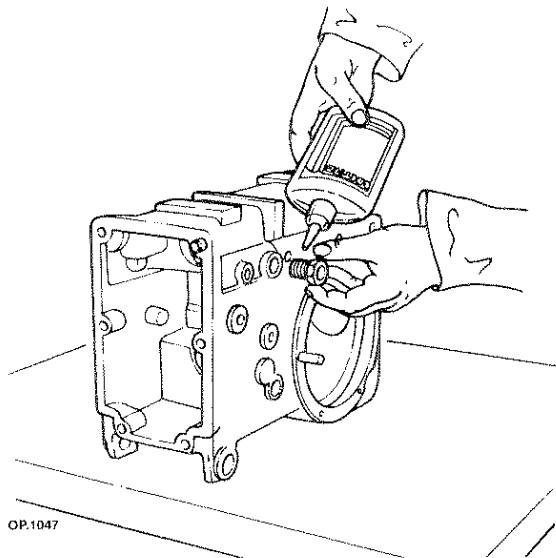

OP.1047

4 - Tighten the PTO engagement bushing with average strong Loctite.

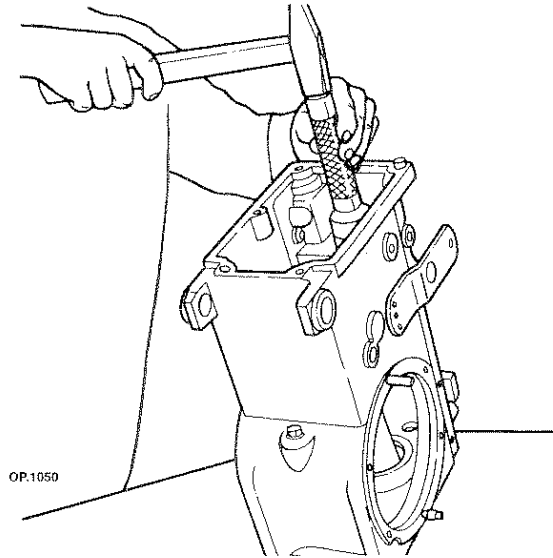

OP.1050

7 - Mount the main shaft and bearing using driver AT 37981276.

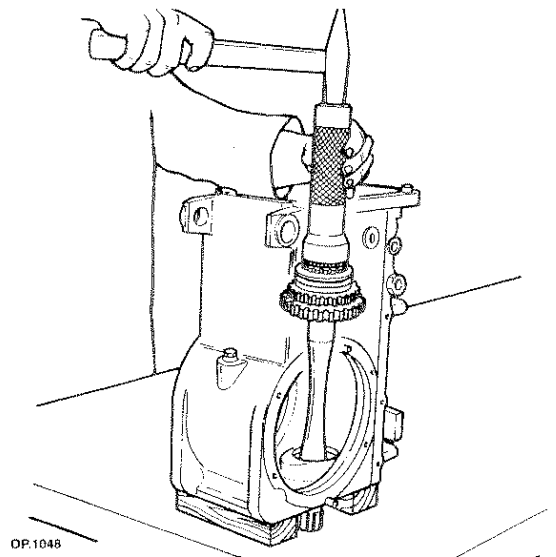

OP.1048

5 - Mount the shaft of the PTO using driver 37981014.

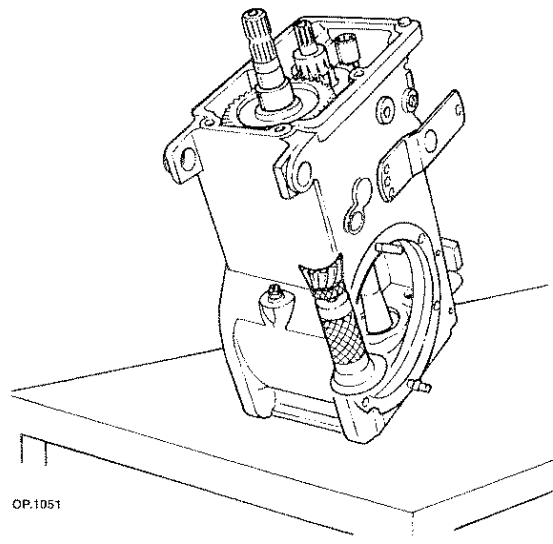

OP.1051

8 - Insert the pinion positioning it with adapter AT 27981109.

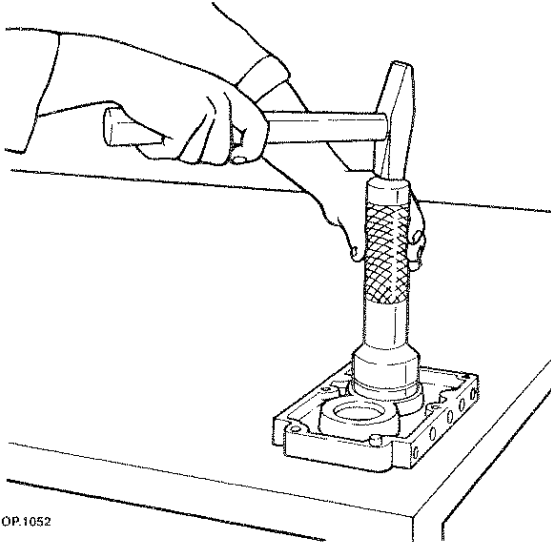

OP.1052

9 - Mount the bearing on the change gear cover with the help of driver AT 37981012.

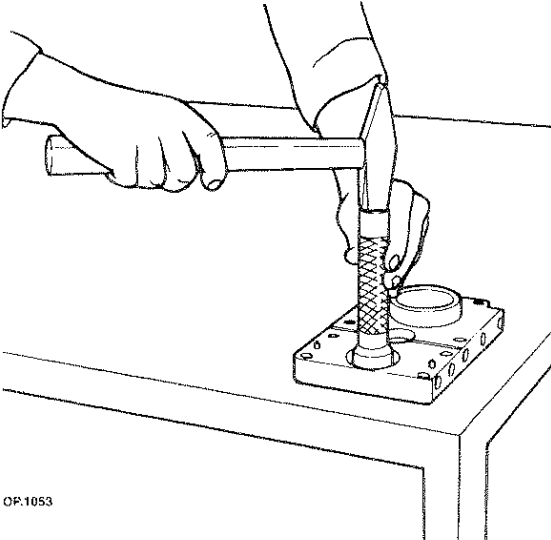

OP.1053

10 - Mount the seal packing using driver AT 37981279.

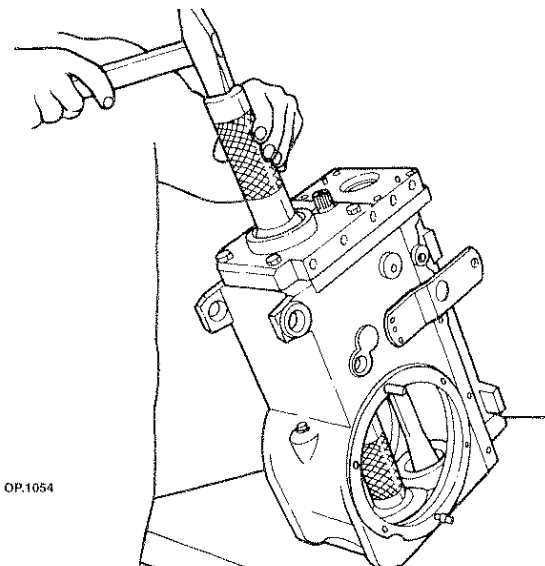

OP.1054

11 - Mount bearing and pinion bushing using driver AT 37991014.

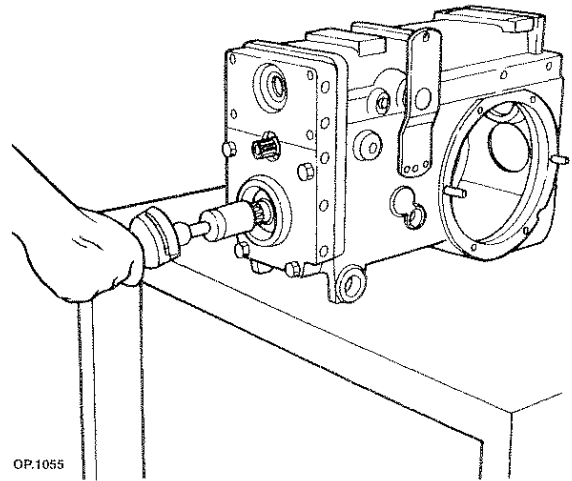

OP.1055

12 - Check the pinion rotating torque and fasten the ring nut as in page 85 - bevel gear bearing preloading.

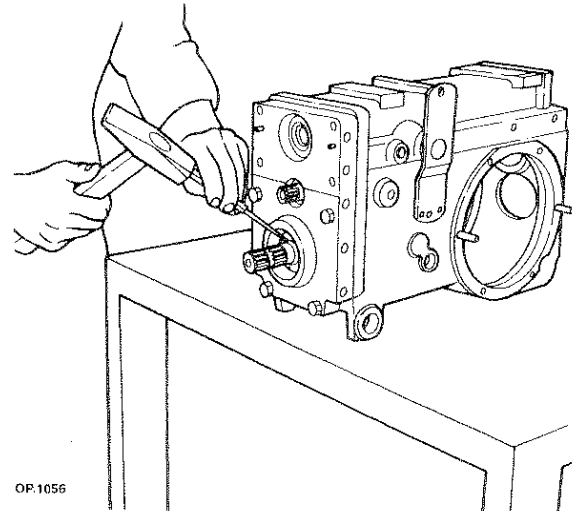

OP.1056

13 - Dent the ring nut.

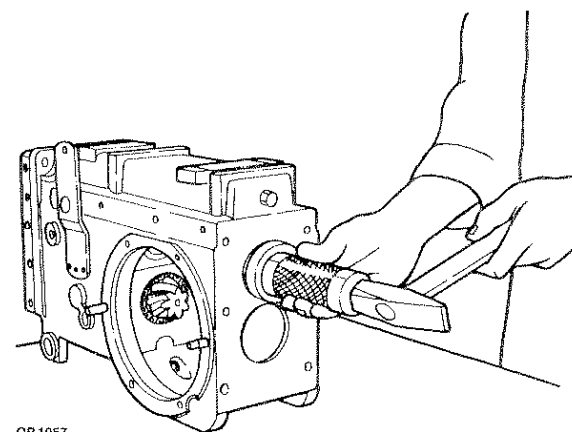

OP.1057

14 - Mount the PTO rear bearing using the driver AT 37981014.

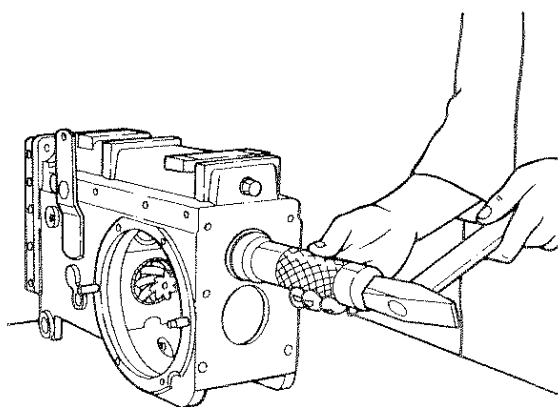

OP.1058

15 - Mount the packing using driver AT 37981292 and adapter AT 37981291.

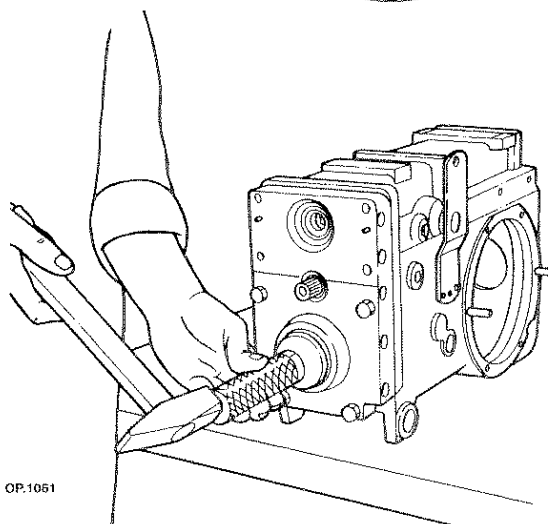

OP.1061

18 - Mount the pinion seal with driver AT 37981289 and adapter at 37981288.

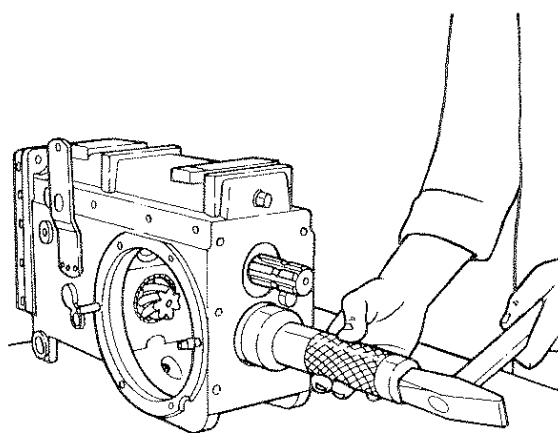

OP.1059

16 - Mount the plug with driver AT 37981012.

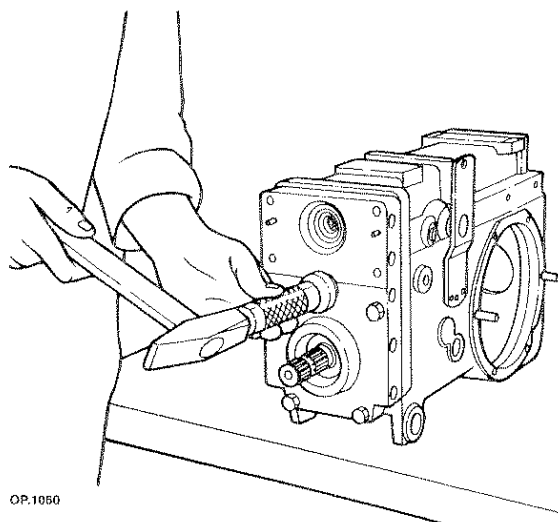

OP.1060

17 - Mount the main shaft packing with driver AT 37981090 and adapter AT 37981020.



WARNING - DANGER



Perform operations by strictly observing accident prevention regulations.

- Do not use gasoline, diesel oil or other flammable liquids to degrease or clean parts but use commercial non-toxic solvents instead.

Dispose of waste fluids, used filter cartridges, oils, lubricants and grease cleaners in the most suitable way and in compliance with regulations in force.

The collection of waste oils must be performed by authorized plants.

Keep environment clean.

- Operations that require special care may be hazardous for the operator if not correctly performed.

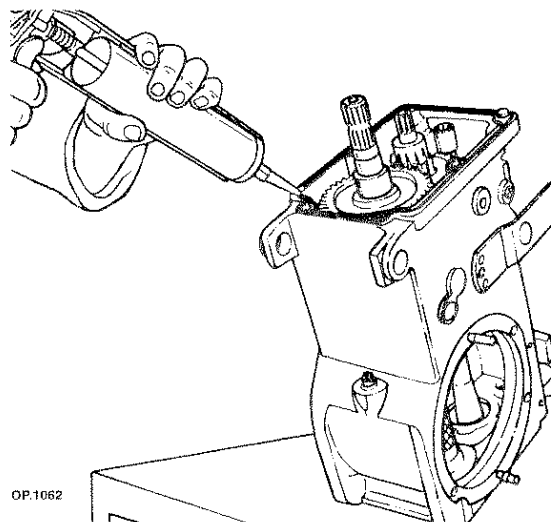

OP.1062

Application diagram of gasket forming compound.



DIFFERENTIAL UNIT

Adjustment of the crown wheel and pinion.

A - Calculation of the thickness of the support ring of the bevel pinion bearing.

The value of said thickness is determined by measuring the height of the pinion head on tool AT 37981283; insert the pinion on the tool AT 37981283 with the bearings, turn ring nut slightly in order to create a revolving momentum (200 Ncm).

Use a dial gauge, place the rod

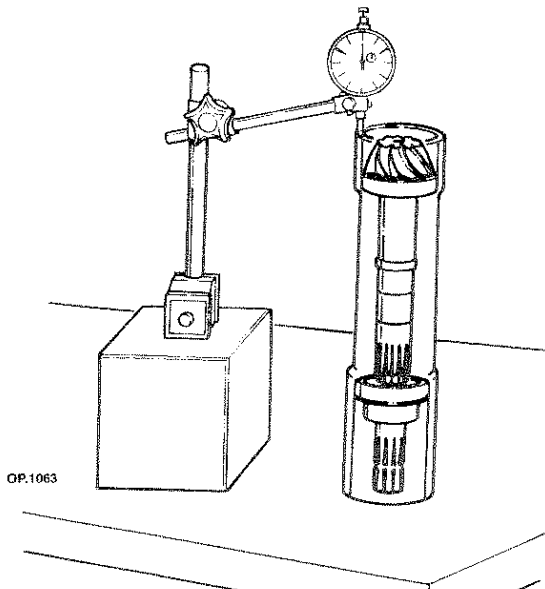

(feeler pin) on a tool and zero set it then pla-

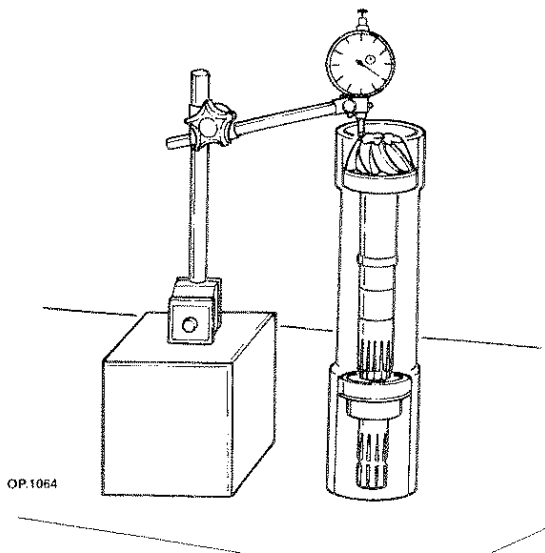

ce it on the pinion head.

The value read must be subtracted from the centesimal value written with an engraver on the head of the pinion.

If (A) is the value measured by the dial gauge and (B) is the one printed by the manufacturer on the pinion, the thickness (S) of the support ring to be mounted is given by the following equation:

$$S = A - (+B) = A - B$$

$$S = A - (\pm B) =$$

$$S = A - (-B) = A + B$$

Example:

A= 1.70 (value read on dial gauge)
 B = 0.15 (centesimal dimensions marked on the pinion by the manufacturer)

$$\text{thickness } S = A - (+/-B)$$

$$= 1.70 - (-0.15)$$

$$= 1.70 + 0.15$$

$$= 1.85$$

In this case a 1.85 mm thick ring must be mounted (underneath the pinion bearing). If necessary round off to the highest figure within 0.05 mm. Therefore the shim to be mounted is 1.9 mm thick.

Note:

The support ring of the roller bearing on the pinion is supplied as spare part:
 mm 1.7 - 1.8 - 1.9 - 2 - 2.1 - 2.2 - 2.3.



B. Pinion bearing preloading

To perform the preloading of the bevel roller bearing of the pinion proceed as follows:

- 1 - Tighten the ring nut with a driving torque of 8 - 10 Kgm (78-98 Nm).
- 2 - Rotate the pinion a few turns so that the bearings are properly positioned in their seat.
- 3 - Loosen the ring nut.
- 4 - Measure the rotating torque (R) necessary to rotate the pinion with all its gearings.

E.g.

$R = 150$ Ncm value read on the torquemeter before fastening the ring nut.

300 Ncm = theoretical preloading value of the bevel roller bearings of the pinion.

RT = rotating resistance of the pinion mounted on the change gear (complete).

$$\begin{aligned} RT &= 300 + R \\ &= 300 + 150 \\ &= 450 \text{ Ncm} \end{aligned}$$

In this case the ring nut must be fastened until you achieve a rotating resistance of the pinion which is equal to 450 Ncm (0.45 Kgm).

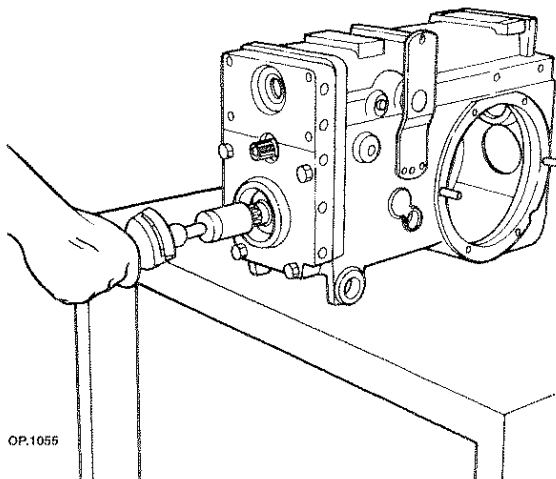

OP.1055

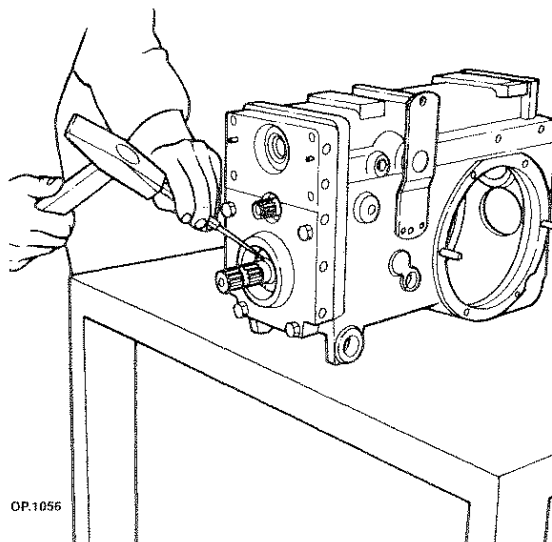

OP.1056

6 - Dent the ring nut.

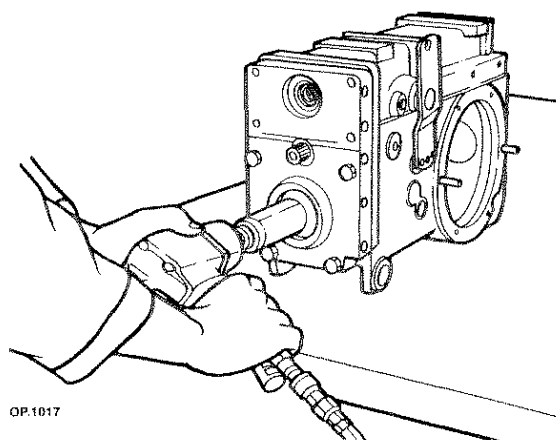

OP.1017

5 - Tighten the ring nut with tool AT 37981280 until you achieve a rotating resistance of the pinion $RT = (300 \text{ Ncm}) + R$ with torquemeter 37981196 and adapter AT 37981281.



WARNING - DANGER



Perform operations by strictly observing accident prevention regulations.

- Wear safety clothing such as gloves and safety shoes.

Watch out for shearing,
Watch out for squeezing,
Watch out for tangling.



C) Adjustment of backlash between the ring gear and the pinion and preloading of the differential box bearings

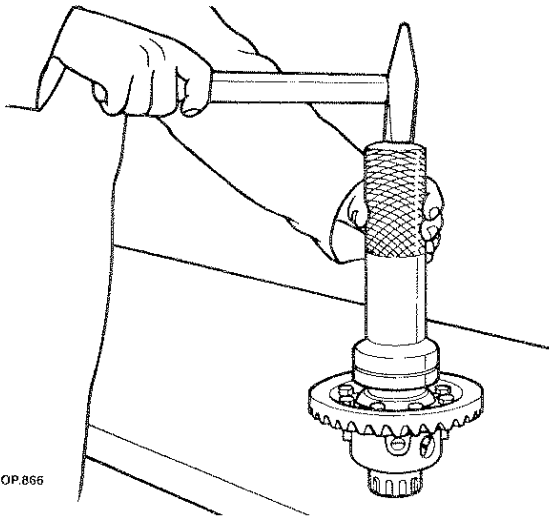

OP.865

1 - Mount the bearing on the differential box using the driver AT 37981093

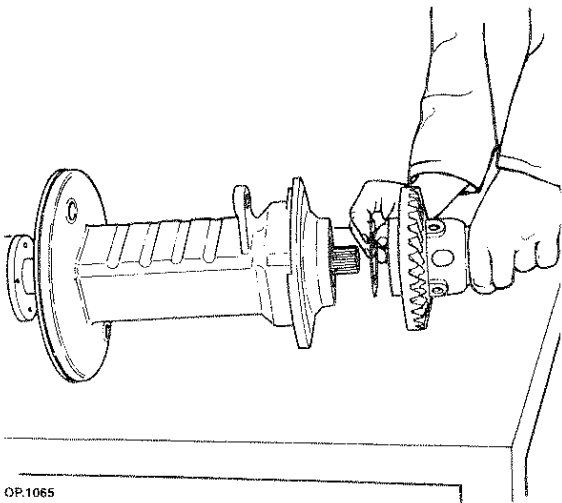

OP.1065

2 - Insert between the differential support and the unit a rated thickness (PS 0.2 mm).

3 - Insert the differential unit on the support with the help of a hammer (plastic or copper).

4 - Mount the differential unit in the transmission box without applying any sealing agent nor fastening it with the screws.

5 - Apply on the side opposite the transmission box the tool AT 27981318 necessary to align the differential unit with the box and slightly preloading the differential bearing.

6 - Apply a centesimal dial gauge with magnetic base over the transmission box, with rod placed as perpendicularly as possible and resting on the edge of a tooth of the ring gear.

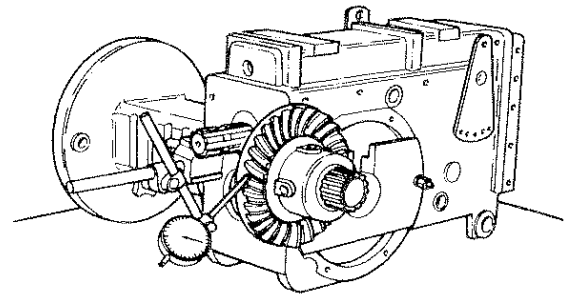

OP.1066

7 - Check the backlash by offsetting it by 120° and comparing the average of the three values with the normally set play (0.15 - 0.23).

8 - If the value measured is higher or lower than the set value, it is then necessary to increase or decrease the value of the rated thickness (PS 0.2).

Note:

Adding a thickness (PS) of 0.1 mm the play between the teeth of the ring gear and pinion is reduced 0.07 mm, whereas by removing a thickness of 0.1 mm the play increases 0.07 mm. The thickness PS is supplied with spares: 0.1 - 0.2 - 0.3 - 0.5 mm.

9 - Remove the differential support and mount the calculated thickness.



10 - Mount the differential support assembly onto the transmission box after having cleaned and degreased the surfaces to be mated and having applied a 3 mm string of gasket forming compound following the path indicated in the figure.

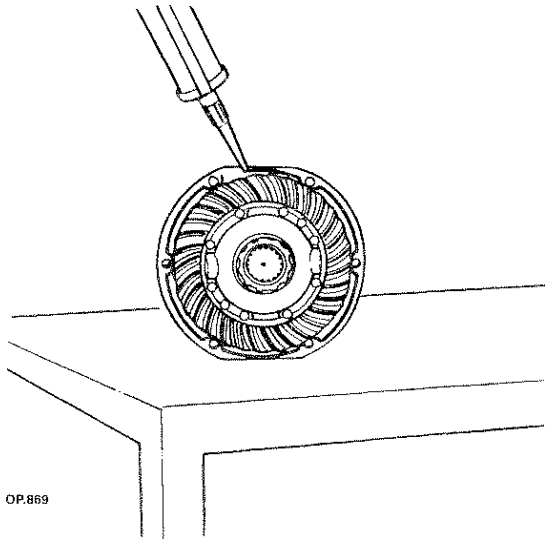

OP.869

- diagram showing application of gasket forming compound.

11 - Observe the driving torque listed at page 4.

12 - Check the backlash between the ring gear and pinion with normal set play of 0.15 - 0.23 mm.

D) Differential box bearing preloading

13. Position the centesimal dial gauge with support AT 27981215 on the mating surface between the support and the box, so that the feeler pin is directly on the seat of the bearing on the differential box and zero-set the dial gauge.

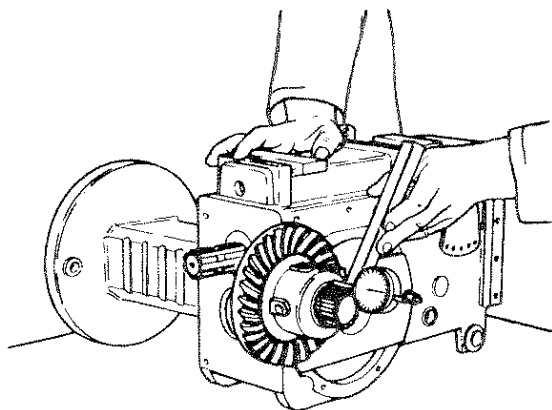

OP.1067

Now position the gauge directly on the bearing of the differential box support so that the feeler pin is in contact with the mating surface of the box.

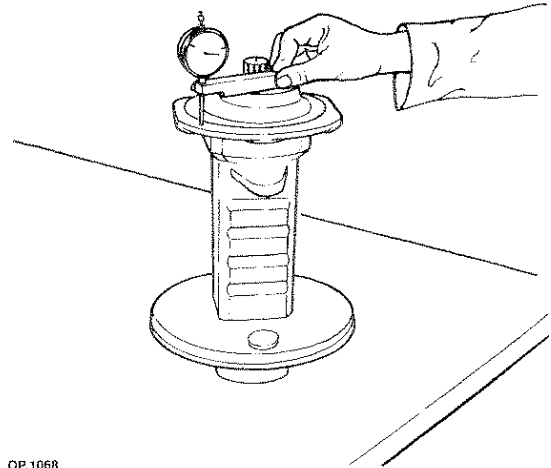

OP.1068

14 - Perform measurement by offsetting it by 120° and the average of the three values Gm added to a preload of 0.1 mm will give you the thickness S to be mounted between the differential box and the bearing of the differential support.

If necessary round off to the highest figure within 0.05 mm.

Example:

Gm = 0.25 average of values read on dial gauge

0.1 mm = major value to increase the preloading of the bearings.

$$\begin{aligned} \text{Thickness } S &= Gm + 0.1 \\ &= 0.25 + 0.1 \\ &= 0.35 \end{aligned}$$

round off to the highest figure 0.05 mm.

In this case you need to mound two 0.2 mm shims = 0.4 mm.



WARNING - DANGER



Perform operations by strictly observing accident prevention regulations.



DIFFERENTIAL

Disassembly - Assembly

When unit is detached from the transmission box proceed as follows:

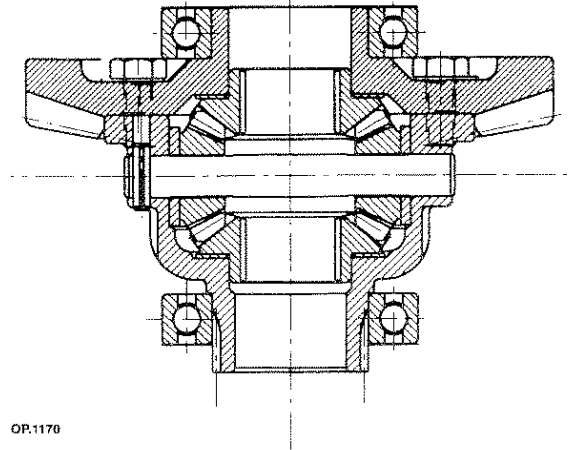

OP.1170

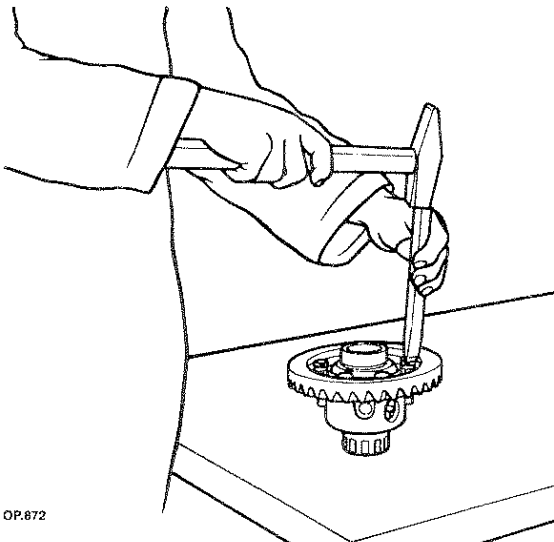

OP.872

1 - Straighten the screw stop plates.

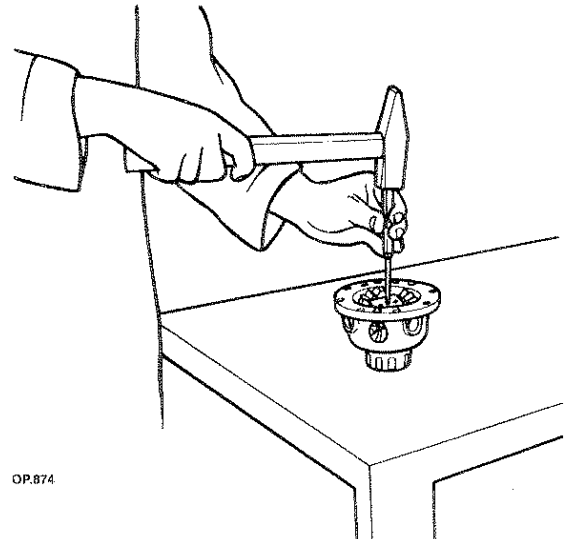

OP.874

3 - Remove the spring pins.

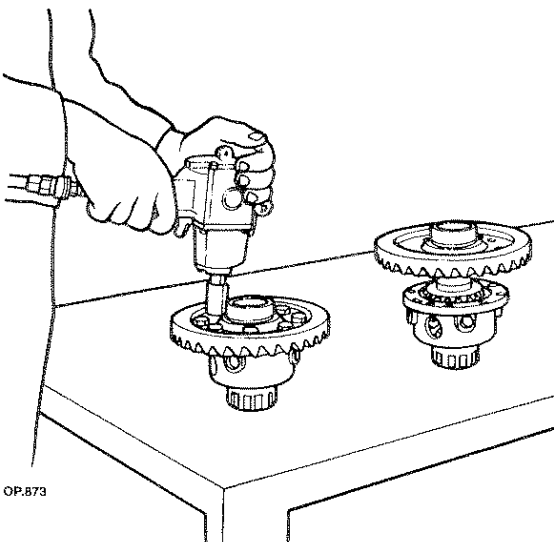

OP.873

2 - Loosen the screws fastening the bevel ring gear.

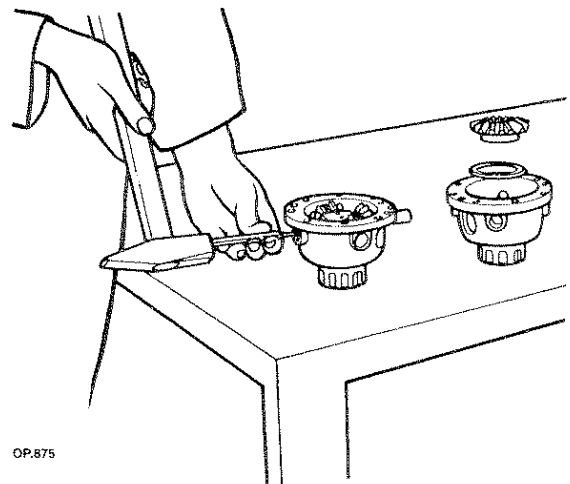

OP.875

4 - Remove the pins, along with the side pinions, the scraper fifth wheels and crown wheels.

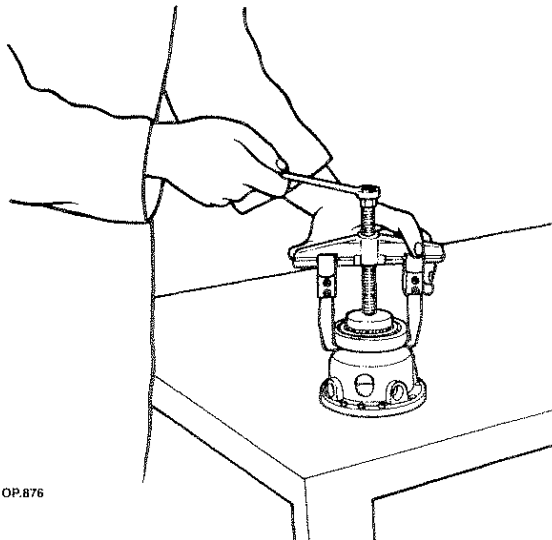

OP.876

5 - Remove the bearing with universal puller AT 37981247 and adapter AT 37981214.



WARNING - DANGER



Keep environment clean. Dispose of oil in compliance with regulations in force. The collection of waste oils must be performed by authorized plants.

ASSEMBLY

Proceed as follows:

- a - proceed inversely as to the disassembly operations.
- b - refer to drawings for location of different parts.
- c - make sure that the groove of the spring pins is oriented towards the stress point so that the spring is under strain.
- d - tighten the screws with a driving torque of 8.5 Kg. (83 Nm).
- e - check the axial play of the crown wheels.

Spring pins:

When mounting the spring pins, make sure that the groove of the spring pins is oriented towards the stress point so that the spring is under strain. Spiral spring pins instead, do not require any orientation.

Checking the crown wheels axial play

To check the axial play of the crown wheels proceed as follows:

1 - Position the feeler pin of the centesimal dial gauge.

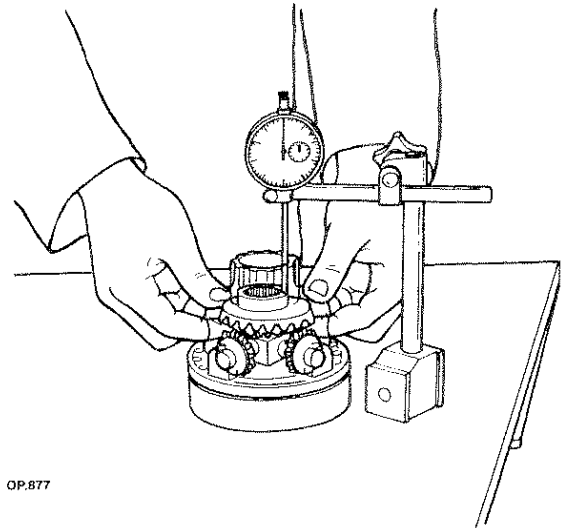

OP.877

2 - Move the crown wheel until it touches the side pinion and then push it against the differential box measuring on the centesimal dial gauge the axial play.

3 - The axial displacement for each crown wheel should be 0.15 - 0.30 mm.



WARNING - DANGER



Perform operations by strictly observing accident prevention regulations.

- Wear safety clothing such as, gloves and safety shoes.
- Do not align slots with hands but use specific tools instead.

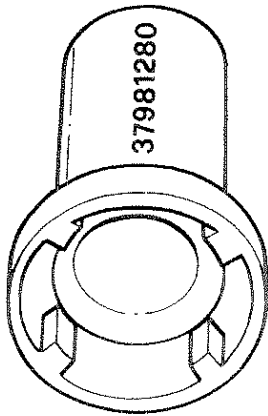

AT.212

1 - Tool for pinion ring nut

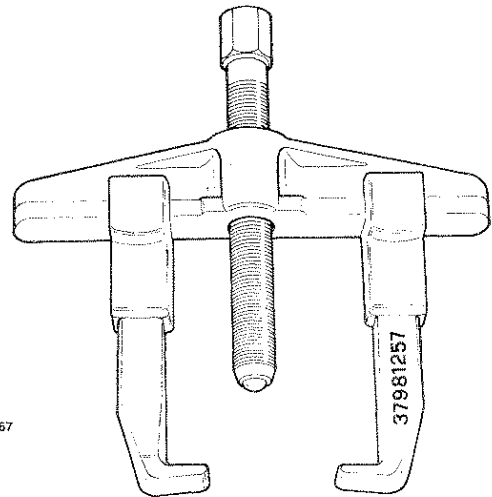

AT.067

4 - Universal extractor

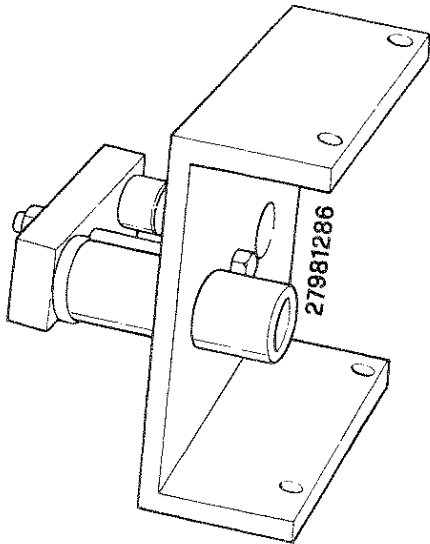

AT.213

2 - Change gear cover puller.

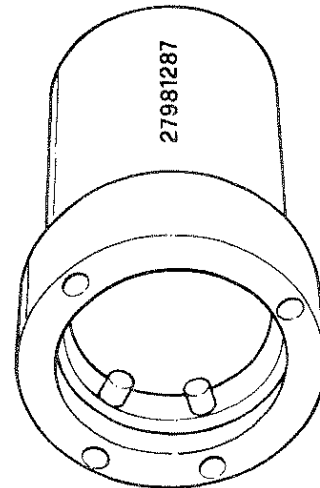

AT.214

5 - Driver for removal of pinion bearing housing.

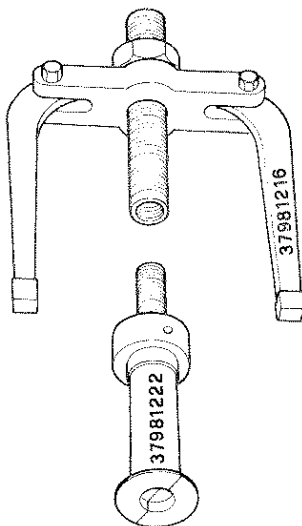

AT.001

3 - Combined extractor AT 36981216 AT 37981222.

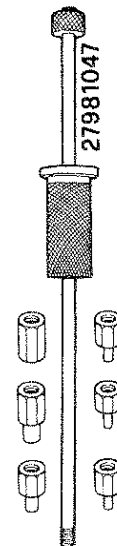

AT.004

6 - Puller with adapter.

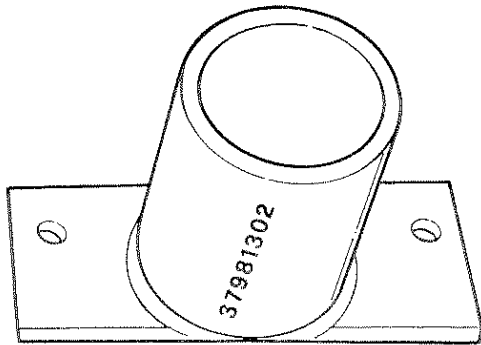

AT.215

7 - Tool for removal of PTO shaft

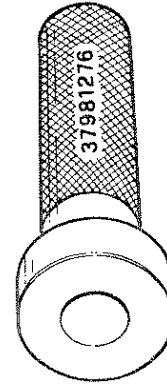

AT.193

10 - Driver for assembly of bearings



AT.015

8 - Driver for assembly of tapered roller bearing

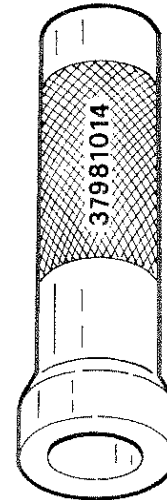

AT.023

11 - Driver for assembly of bearings

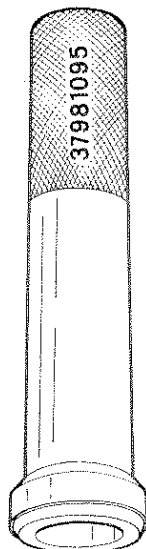

AT.017

9 - Driver for mounting of tapered roller bearing housing

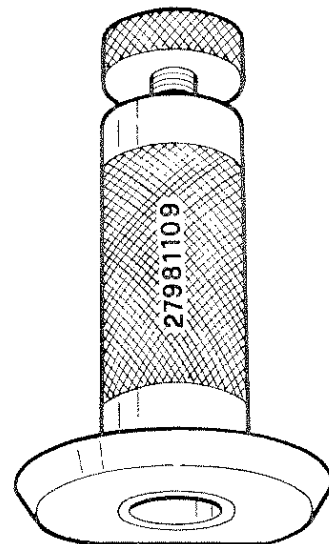

AT.018

12 - Differential pinion stop

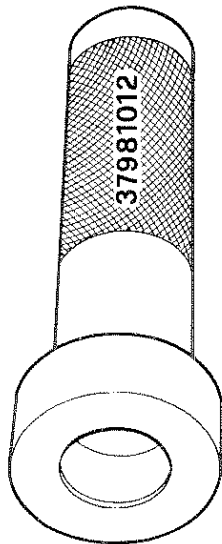

AT.037

13 - Driver for mounting of bearings

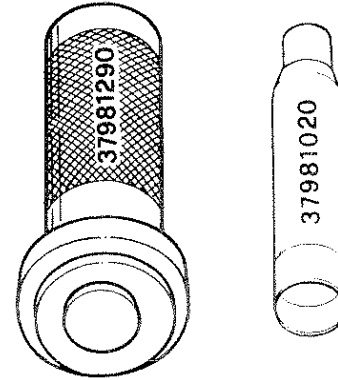

AT.219

16 - Driver and adapter for mounting of packing

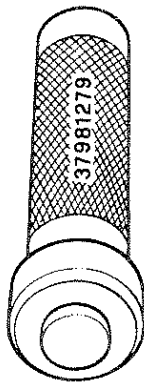

AT.192

14 - Driver for mounting of main shaft seal ring

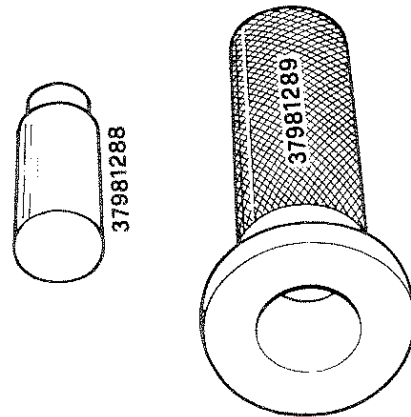

AT.220

17 - Driver and adapter for mounting of packing

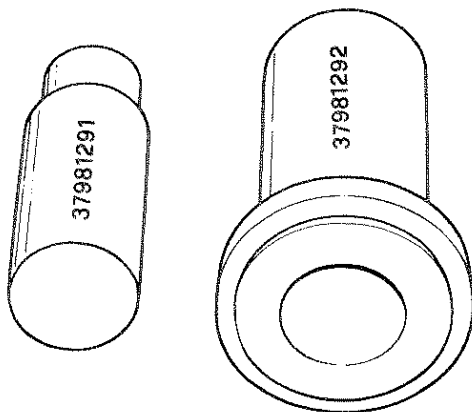

AT.218

15 - Driver and adapter for mounting of packing

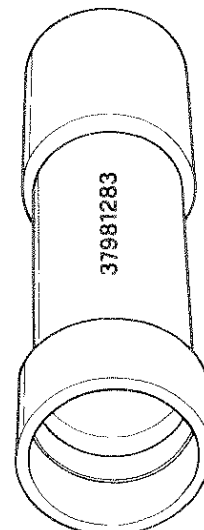

AT.221

18 - Tool to determine the thickness of the pinion bearing

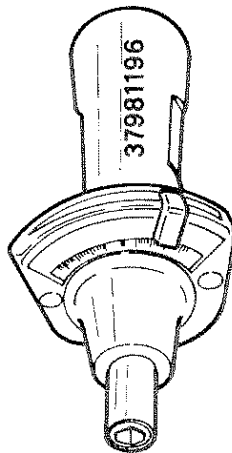

AT.020

19 - Torquemeter Ncm

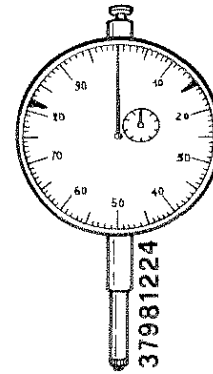

AT.026

22 - Centesimal gauge

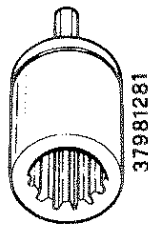

AT.201

20 - Tool for the control of the pinion rotating torque



AT.027

23 - Extension for centesimal gauge

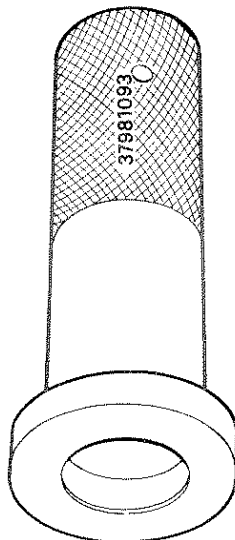

AT.045

21 - Driver for bearings

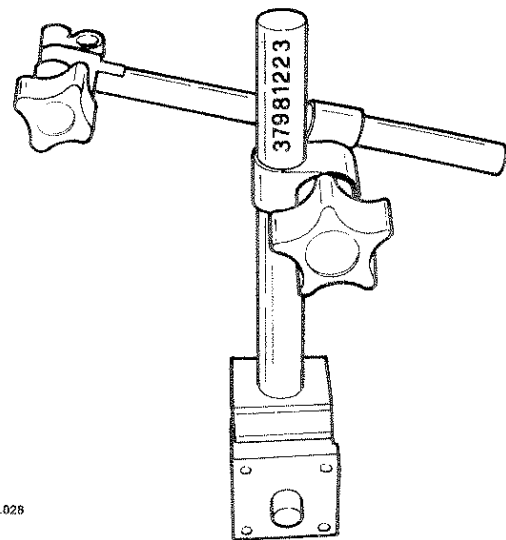

AT.028

24 - Magnetic support for centesimal gauge

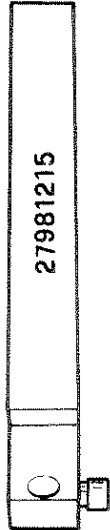

AT.031

25 - -Support for centesimal gauge

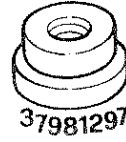

AT.223

28 - Adapter for removal of driver

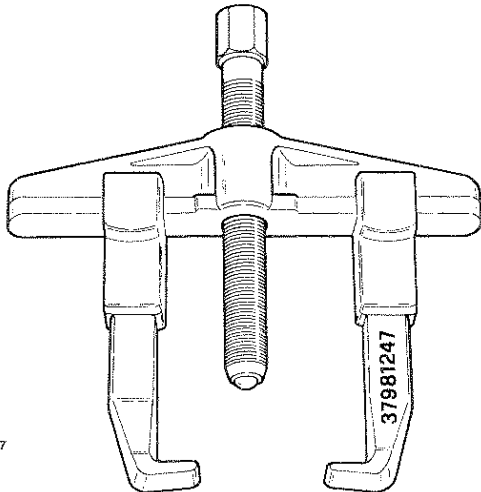

AT.007

26 - Universal puller

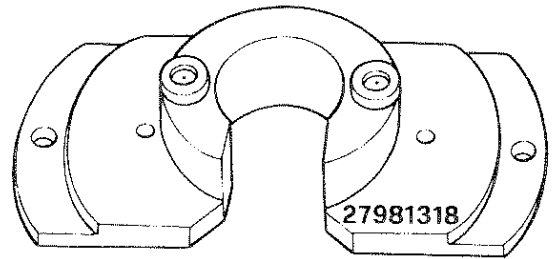

AT.204

29 - Tool for alignment differential unit

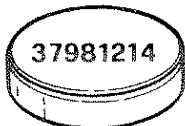

AT.032

27 - Adapter for removal of differential box bearing

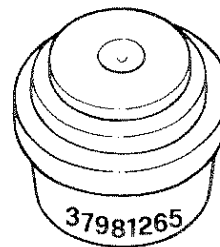

AT.094

30 - Adapter for universal puller



FRONT AXLE ASSEMBLY

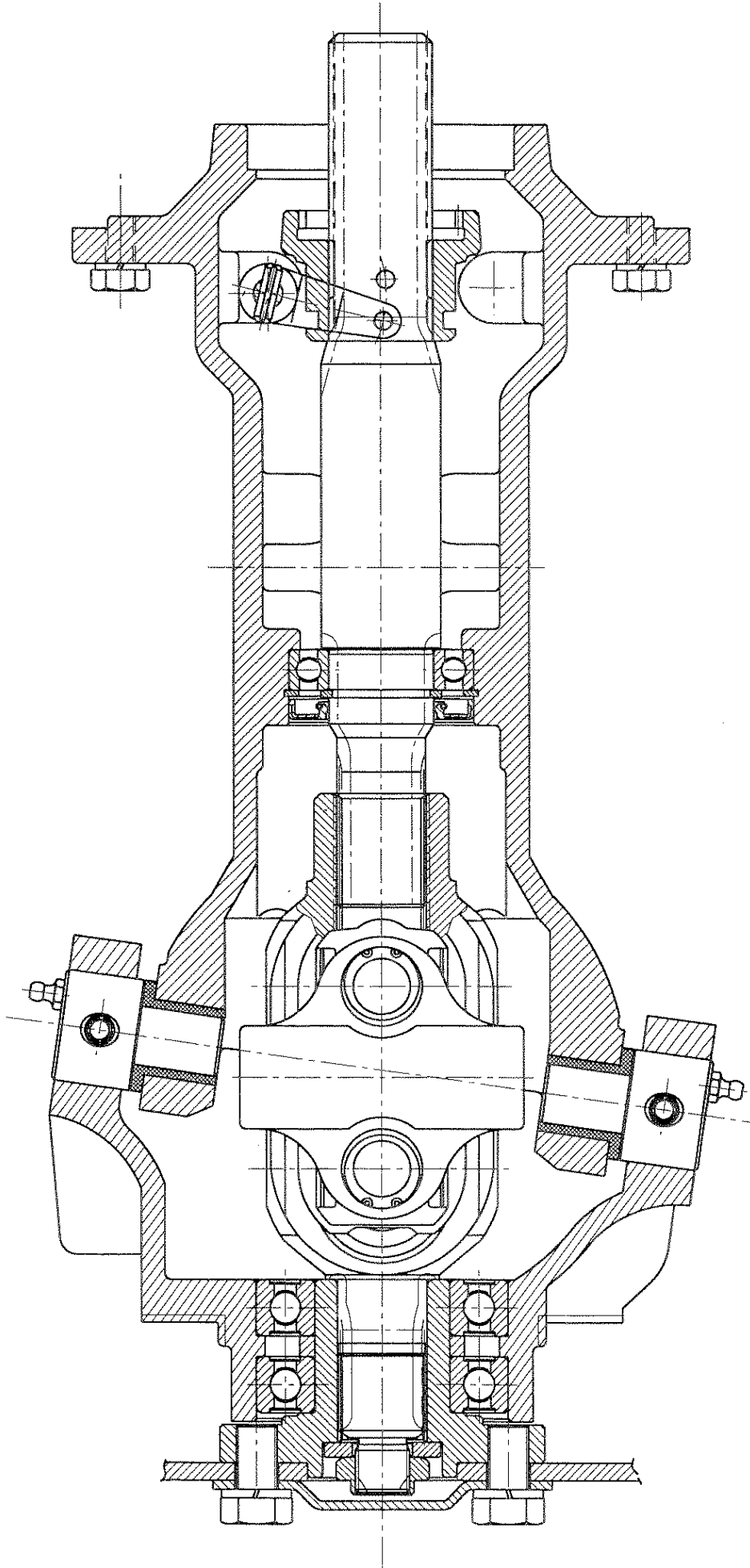



REAR AXLE ASSEMBLY

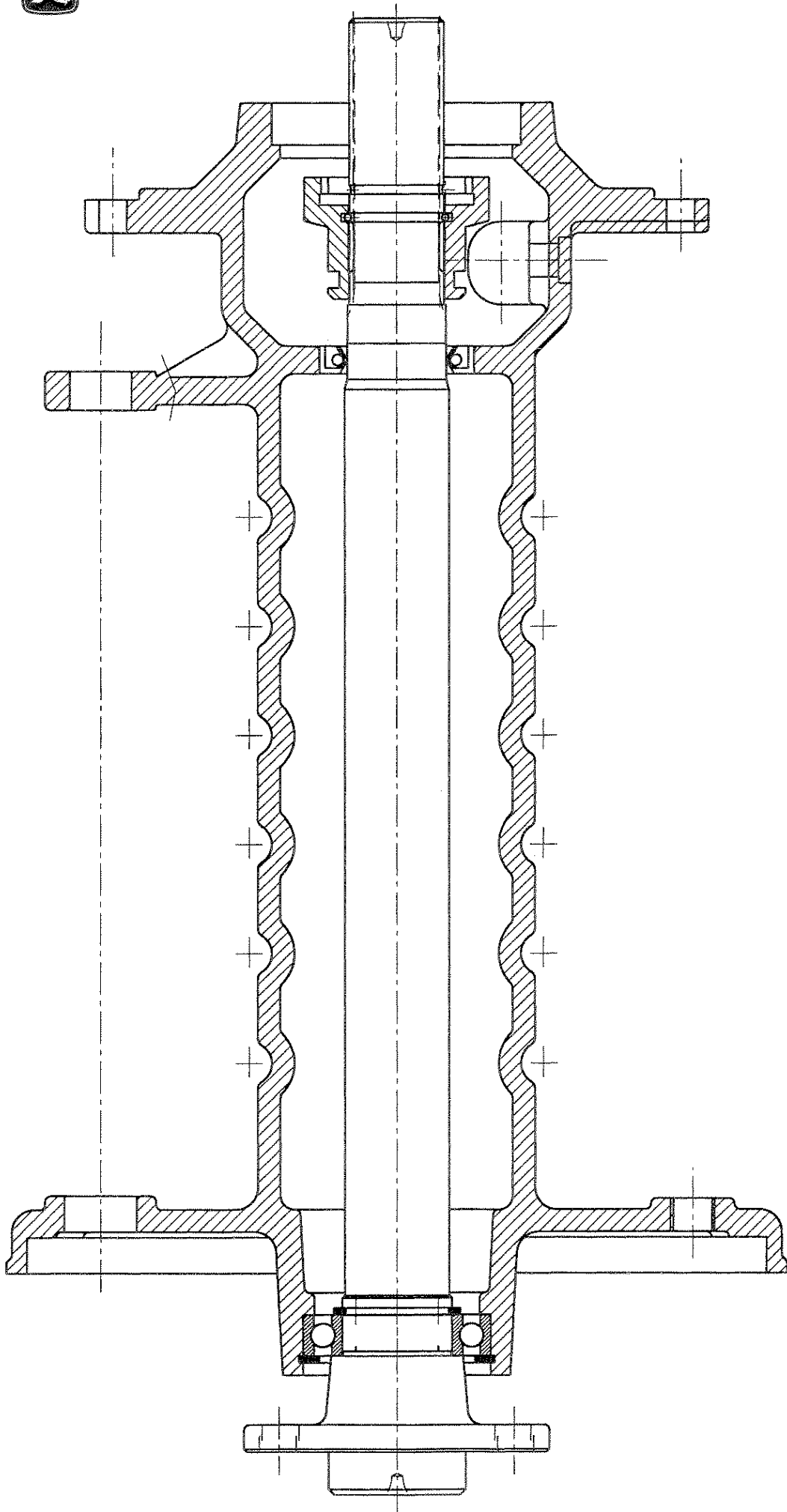



FRONT AXLE

Disconnecting and connecting

Tigretrac

To have access to the front axle unit proceed as follows:

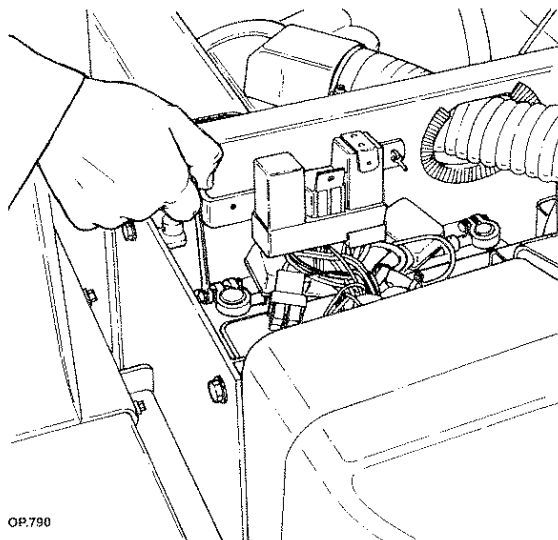

OP.790

1 - Disconnect the battery wire and insulate it.

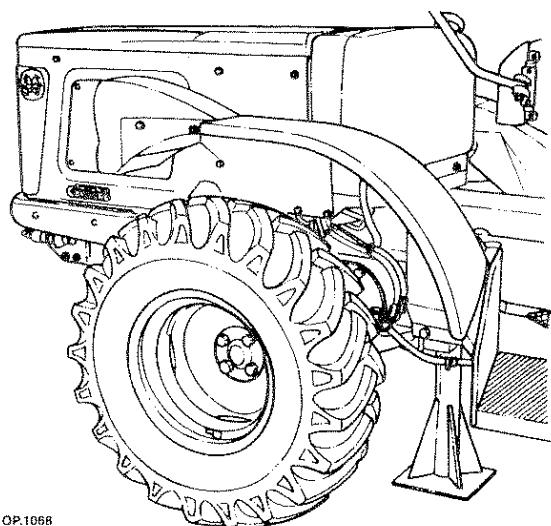

OP.1068

2 - Place a fixed horse underneath the central transmission- front side.

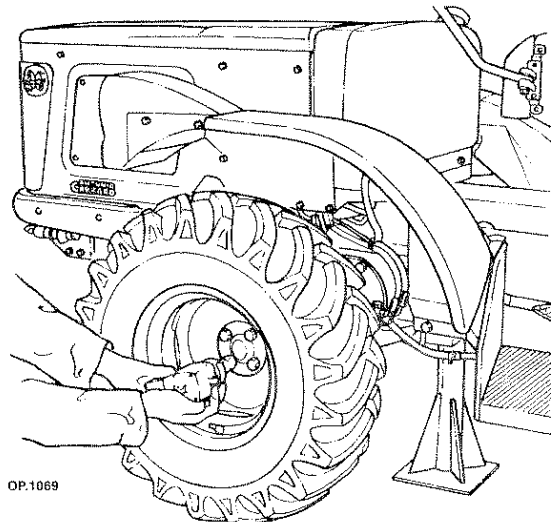

OP.1069

3 - Loosen the screws and remove the front wheels.

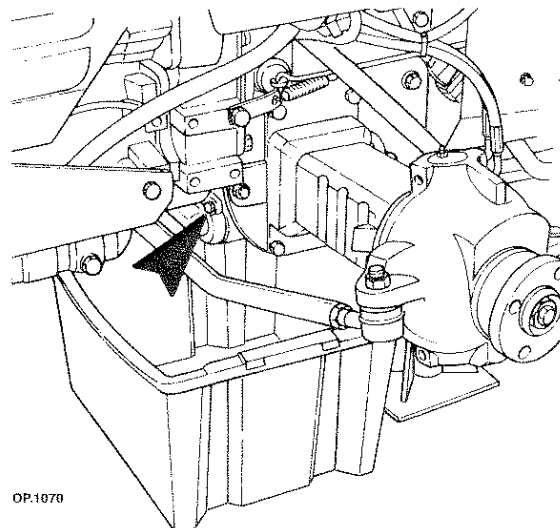

OP.1070

4 - Loosen the screws and remove the hydraulic oil suction filter cover and drain oil inside the special container.

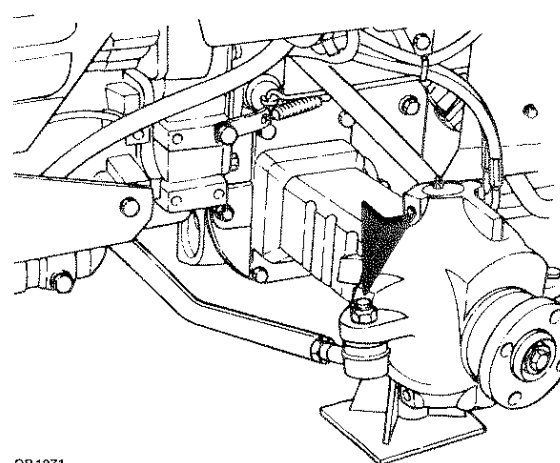

OP.1071

5 - Loosen the fastening nuts of the coupling bar of the steering and remove it.

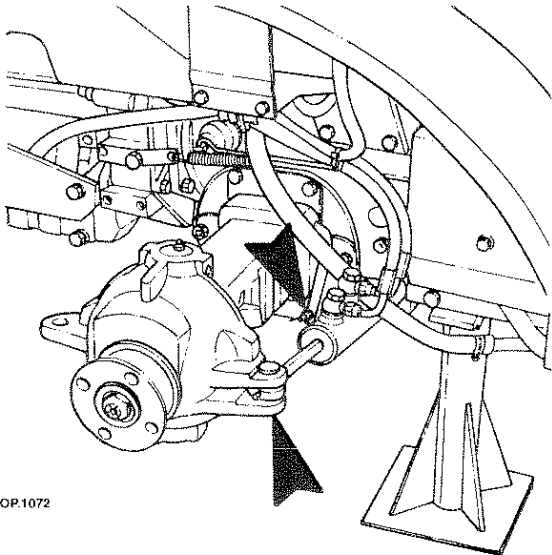

OP.1072

6 - Remove the spring ring and remove the cylinder pin of the steering using a special push rod.

7 - Loosen the wire clamp locking the differential and remove it.

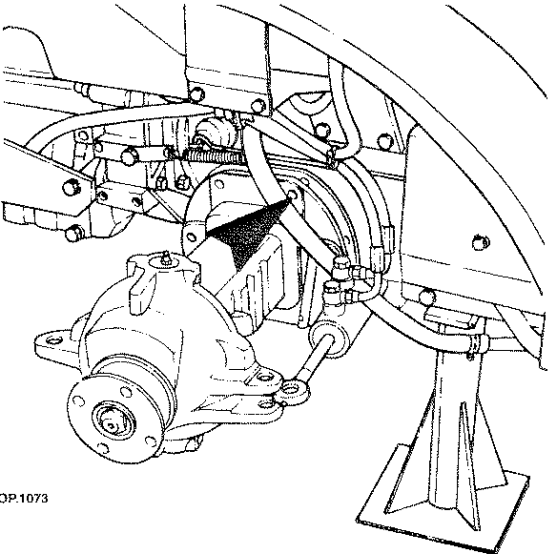

OP.1073

8 - Loosen the screws of the axle with differential clamping and remove it from the transmission box recovering the adjustment shims of the differential box.

9 - Loosen the axle screws opposite the differential locking and remove it together with the whole differential box.

**WARNING - DANGER**

Perform operations by strictly observing accident prevention regulations.

- Use suitable hoisting means.

**WARNING - DANGER**

Perform operations by strictly observing accident prevention regulations.

- Do not use gasoline, diesel oil or other flammable liquids to degrease or clean parts but use commercial non-toxic solvents instead.

Connection

Proceed to the connection, bearing in mind the following instructions:

a - clean all parts to be mated carefully.

b - apply a 3 mm string of gasket forming compound following the path indicated in the figure.

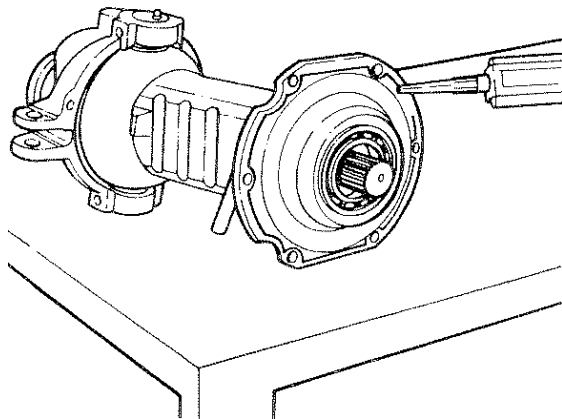

OP.1074

- application of gasket forming compound

c - observe the driving torques listed at page 4

d - proceed inversely as to the disconnection.

e - accurately clean the oil filter and clean all parts of the system that are in contact with the hydraulic oil of the circuit.



FRONT AXLE

Disconnecting and connecting

Superpark

To have access to the front axle unit proceed as follows:

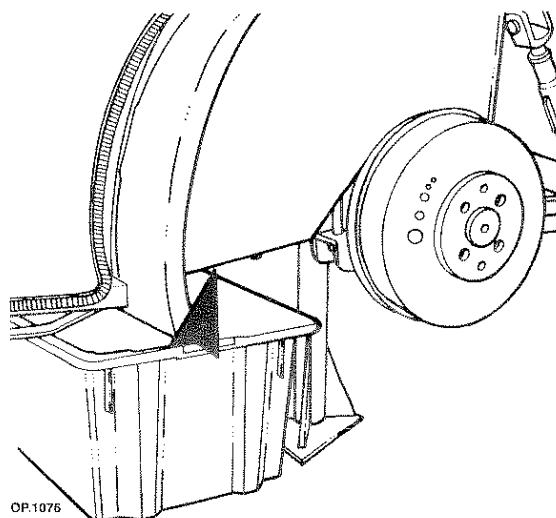

OP.1076

4 - Loosen the gearbox oil drain plug and drain oil in a special container.

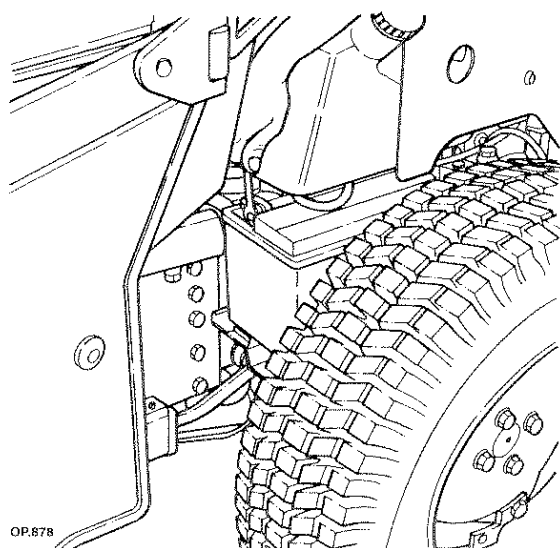

OP.878

1 - Disconnect the battery wire and insulate it.

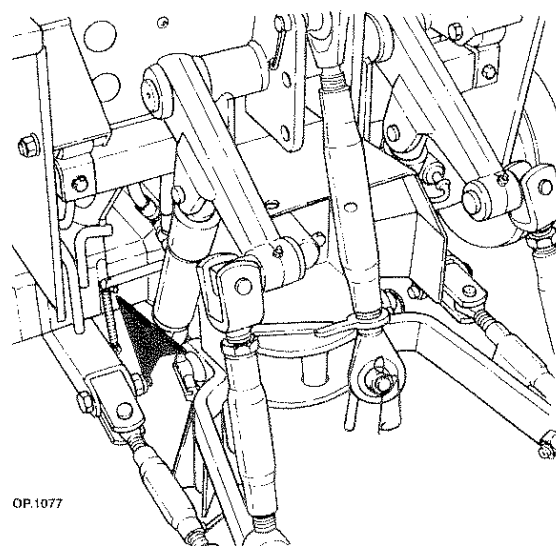

OP.1077

5 - Loosen the wire clamps of the differential locking control and the disengagement of the traction.

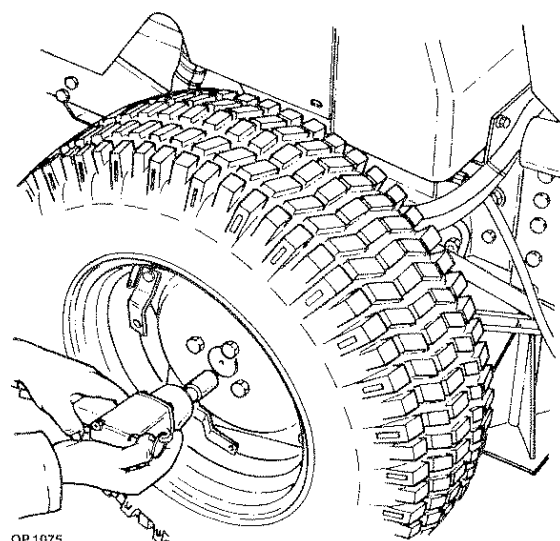

OP.1675

2 - Place a fixed horse underneath the central transmission.

3 - Loosen the screws and remove the front wheels.

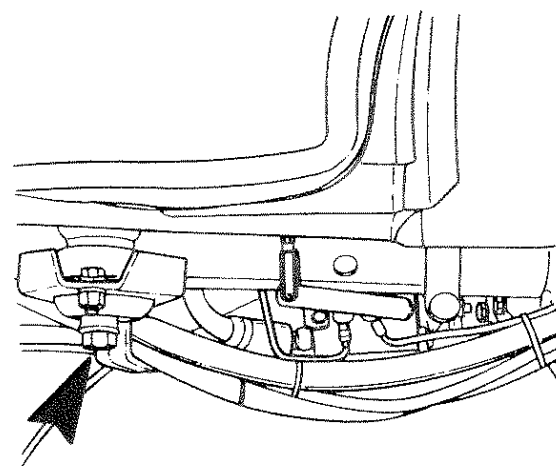

OP.1078

6 - Loosen the cab supporting screws.

7 - Remove the speed-fix control fork.



WARNING - DANGER



Perform operations by strictly observing accident prevention regulations.

- Use suitable hoisting means.
- Wear gloves to handle metal cords or chains.

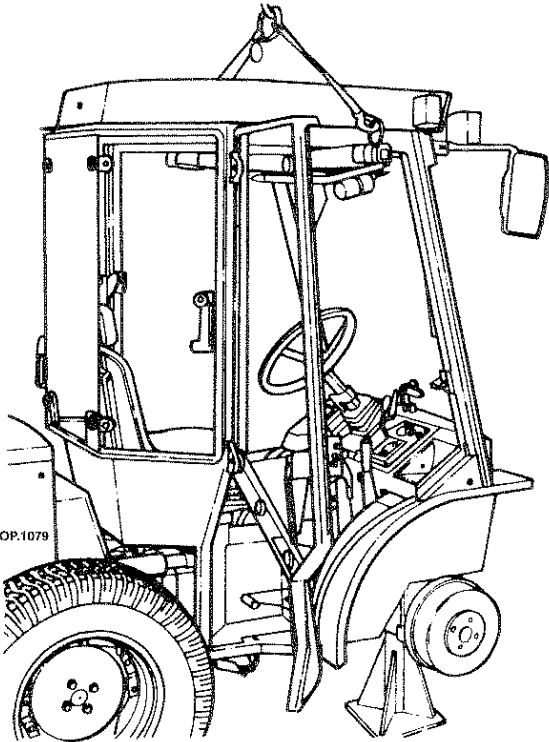

OP.1079

8 - Sling the back of the cab with a cord and hook it to a hoist and hoist it high enough to place a wooden 30 mm spacer between the cab and the silent bloc.

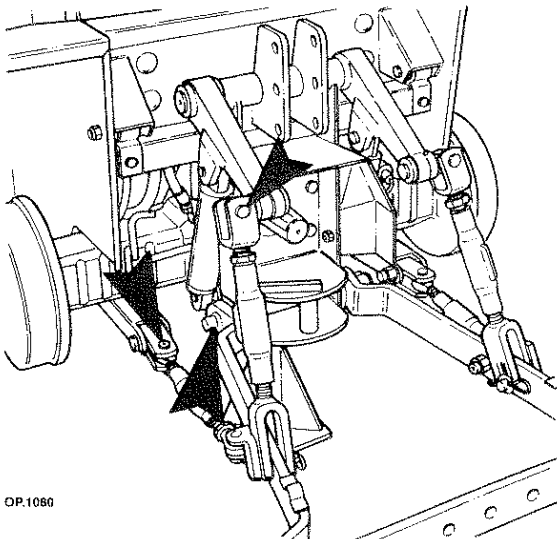

OP.1080

9 - Disconnect the tie-rods and the hoisting bars.

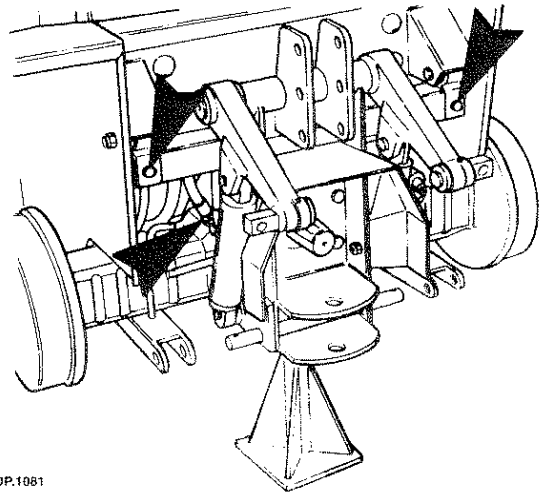

OP.1081

10 - Loosen the unions of the hoisting cylinders delivery tubes and plug them.
11 - Loosen the front cab supporting screws.

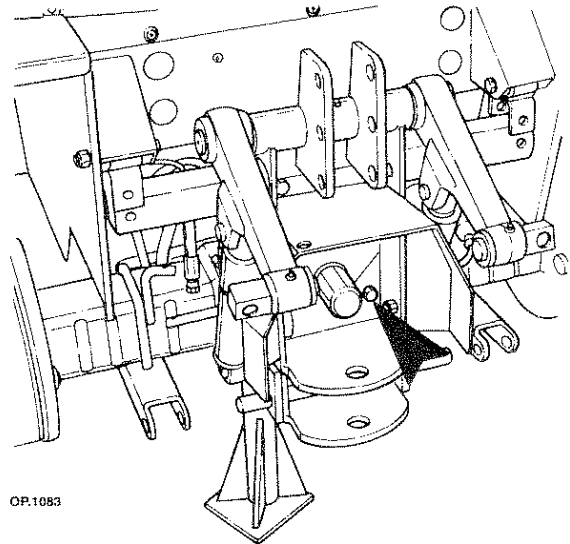

OP.1083

12 - Loosen the screws and remove the hoisting support cover and the cab.

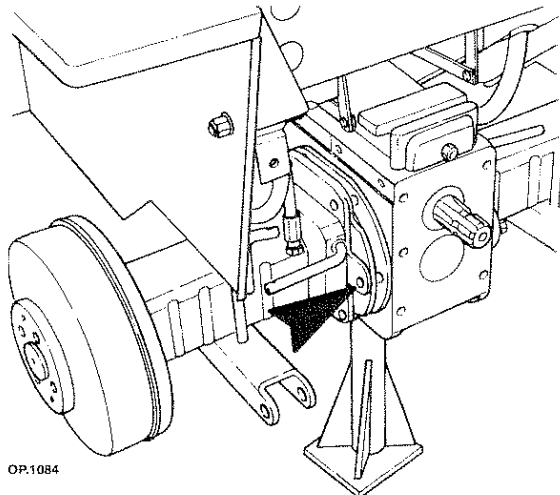

OP.1084

13 - Loosen the screws of the axle with differential locking and remove the adjustment shims of the differential box.



14 - Loosen the screws of the axle opposite the differential locking and remove the whole differential box.



WARNING - DANGER



Perform operations by strictly observing accident prevention regulations.

- Do not use gasoline, diesel oil or other flammable liquids to degrease or clean parts but use commercial non-toxic solvents instead.

Connection

a - clean carefully, especially the surfaces to be mated.

b - apply a 3 mm string of gasket forming compound following the path indicated in the figure:

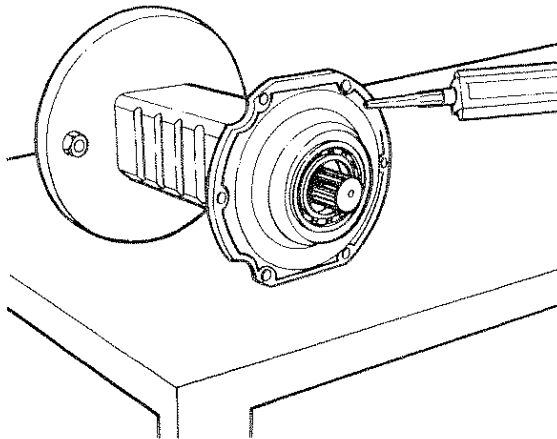

OP.839

Application diagram of gasket forming compound

c - observe the driving torques listed at page 4.

d - proceed inversely as to the disconnection.

e - accurately clean the oil filter and clean all parts of the system that are in contact with the hydraulic oil of the circuit.



WARNING - DANGER



Keep environment clean. Dispose of waste fluids, used filter cartridges, oils, lubricants and grease cleaners in the most suitable way and in compliance with regulations in force. The collection of waste oils must be performed by authorized plants.

Disassembly - assembly

Tigretrac

For the disassembly of the front axle proceed as follows:

1 - Loosen the axle unit over a workbench.

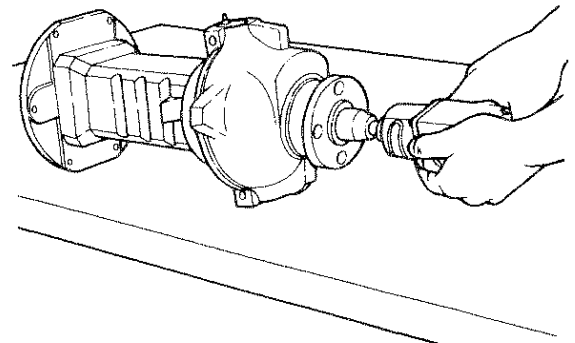

OP.1085

2 - Loosen the nut of the universal semishaft.

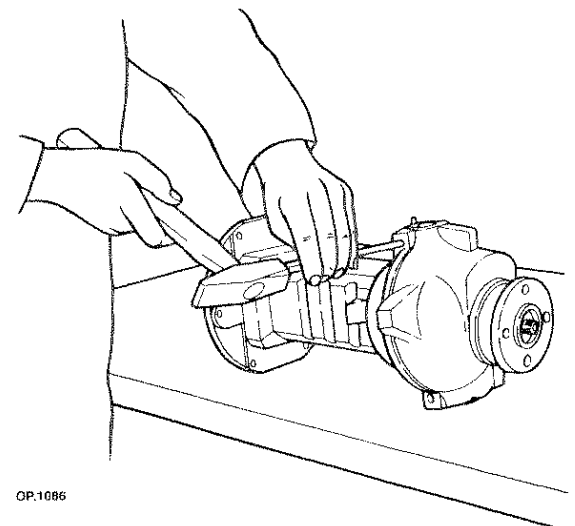

OP.1086

3 - Remove the spring retainer pins of the articulation pins.

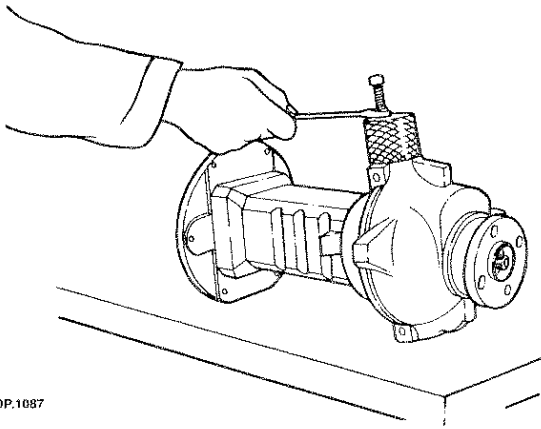

OP.1087

- 4 - Remove the grease nipples from the bushing.
5 - Replace the greaser nipple with the tool AT 37981044 and remove the bushings - pins.

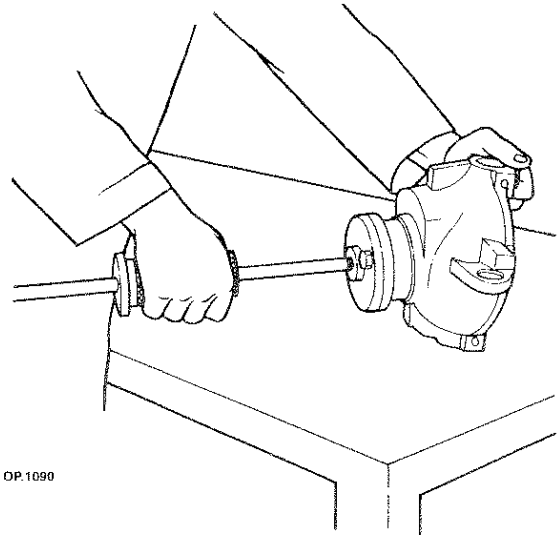

OP.1090

- 8 - Remove the wheel hub with puller AT 27981047 and adapter AT 37981270.

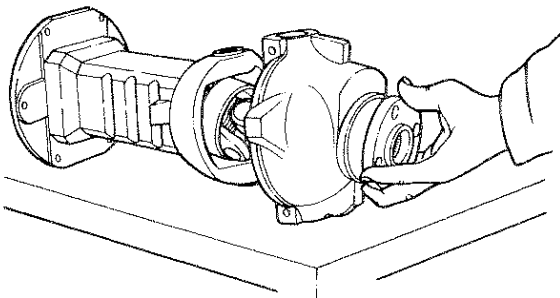

OP.1088

- 6 - Separate the hub from the axle steering.

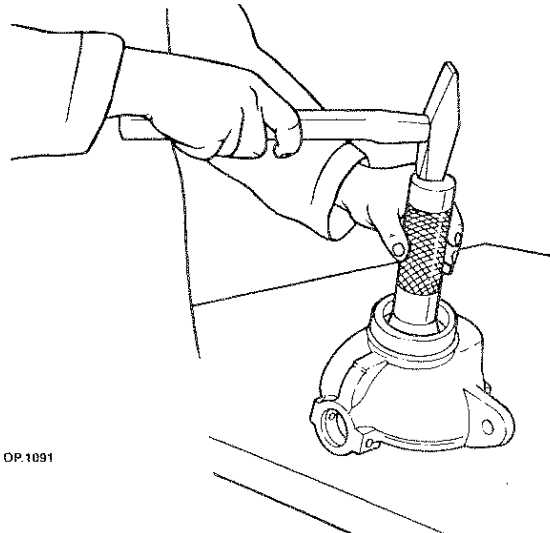

OP.1091

- 9 - Remove the bearing using a driver AT 37981014.

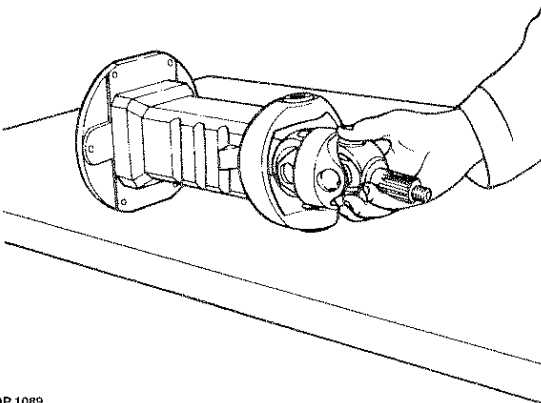

OP.1089

- 7 - Remove the universal joint.

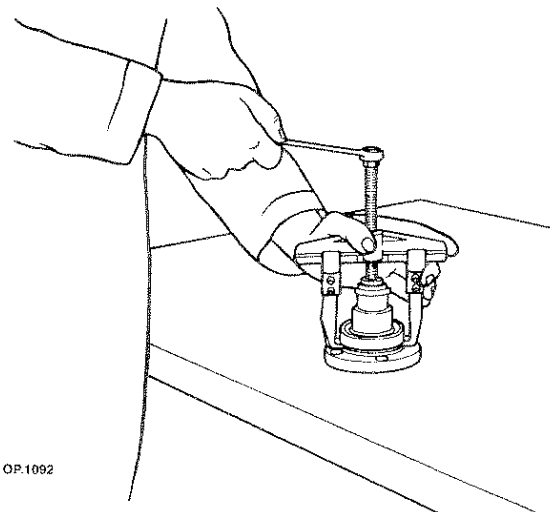

OP.1092

- 10 - Remove the bearing with tool AT 37981257 and adapter AT 37981265.

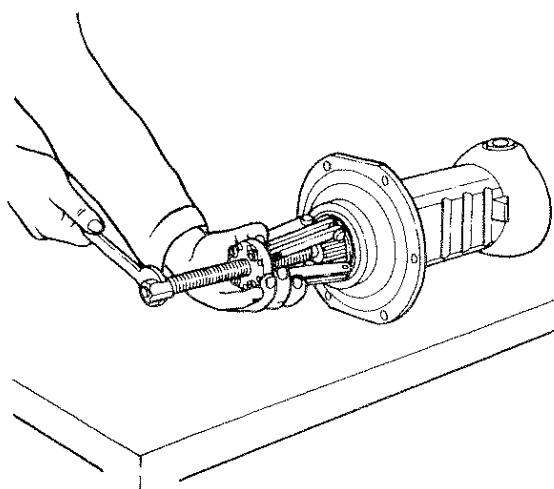

OP.1093

11 - Remove the bearing with puller AT 37981261.

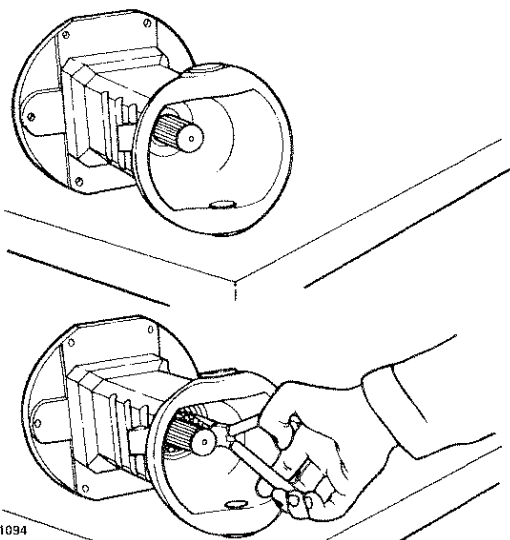

OP.1094

12 - Remove the packing and remove the shaft retainer ring.

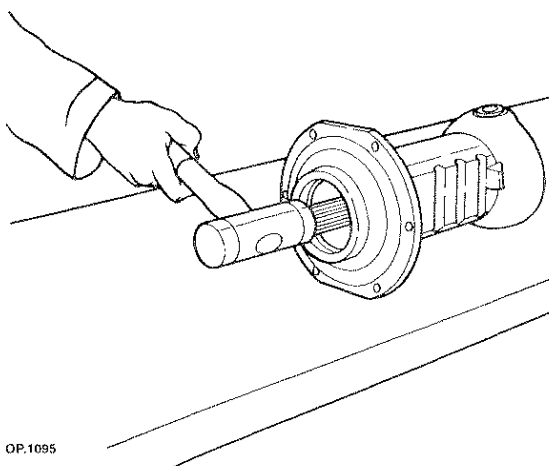

OP.1095

13 - Remove the shaft along with the locking engagement.

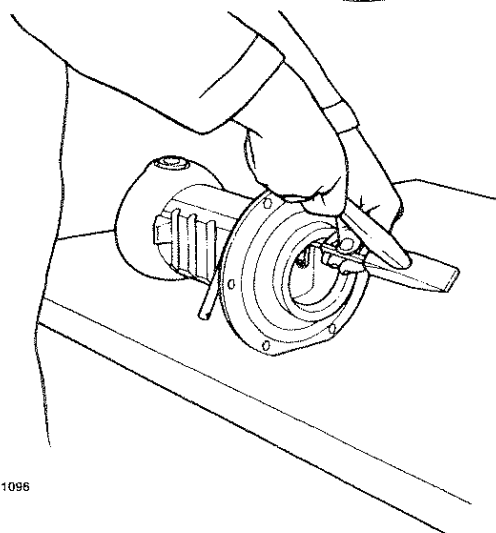

OP.1096

14 - Remove the spring pin and remove the shaft that controls the locking along with the engagement fork.

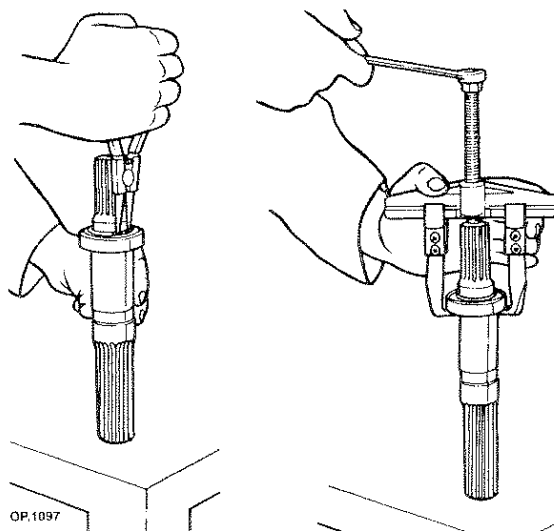

OP.1097

15 - Remove the retainer ring and remove the bearing with the puller AT 37981257.



WARNING - DANGER



Perform operations by strictly observing accident prevention regulations.

- Wear safety clothing such as, gloves and safety shoes.



ASSEMBLY

Proceed to the assembly of the unit, bearing in mind the following instructions:

a - proceed inversely as to the disassembly operations.

b - observe the pictures for the location of the different components.

c - observe the driving torques listed at page 4.

d - dent the universal shaft nut.

e - follow the operations below:

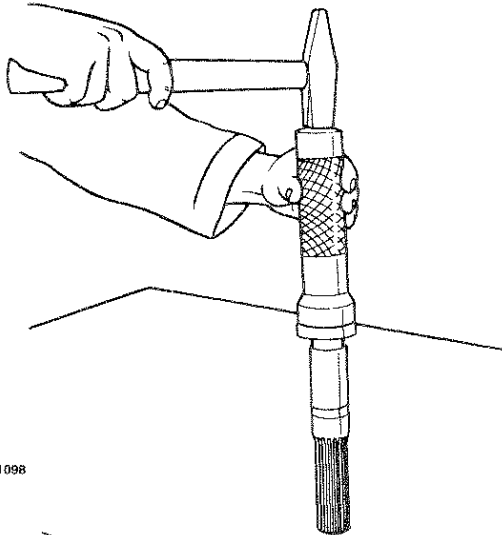

OP.1098

1 - Mount the bearing on the shaft with driver AT 37981014.

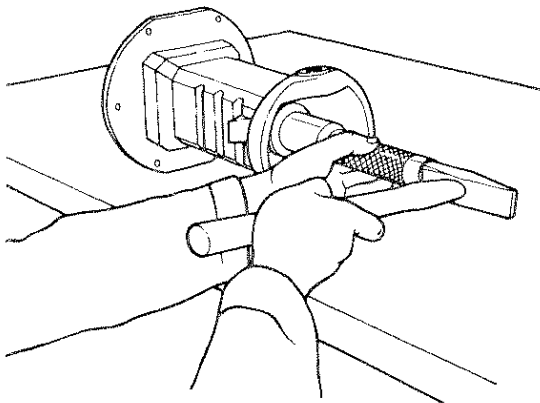

OP.1099

2 - Mount the packing with driver AT 37981326 and the adapter AT 37981327.

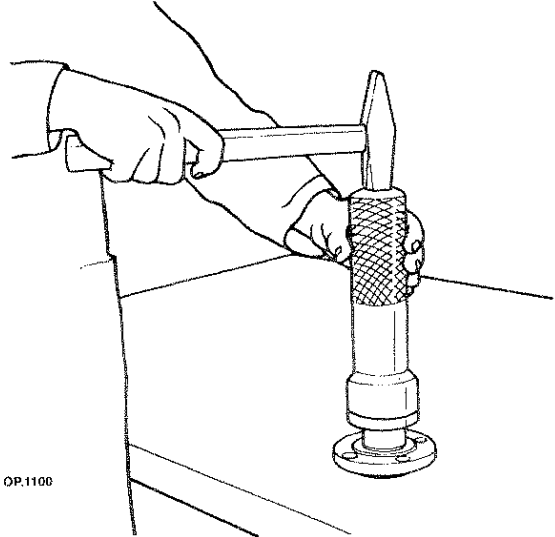

OP.1100

3 - Mount the bearing on the wheel hub with driver AT 37981328.

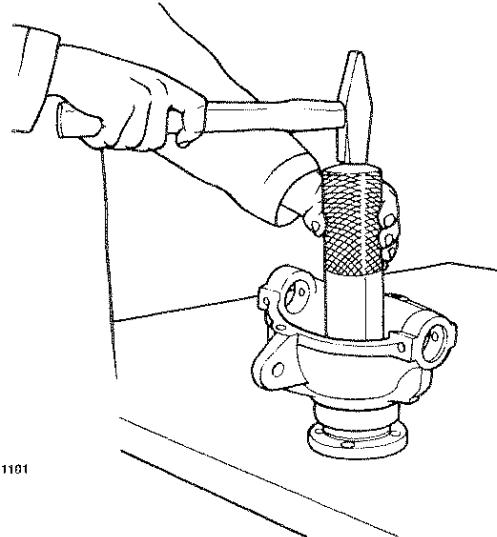

OP.1101

4 - Mount the bearing with driver AT 37981328.



WARNING - DANGER



Keep environment clean. Dispose of waste fluids, used filter cartridges, oils, lubricants and grease cleaners in the most suitable way and in compliance with regulations in force. The collection of waste oils must be performed by authorized plants.



WARNING - DANGER



Perform operations by strictly observing accident prevention regulations.

- Operations that require special care may be hazardous for the operator if not correctly performed.

Superpark

Disassembly

To disassemble the front axle, proceed as follows:

1 - Place the axle over a bench.

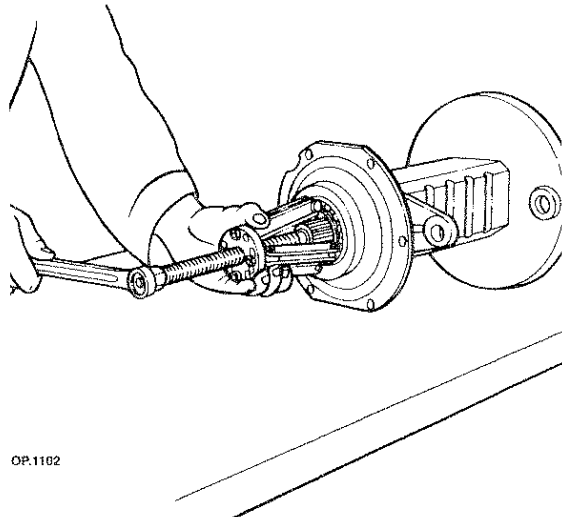

OP.1102

2 - Remove the bearing using the puller AT 37981261.

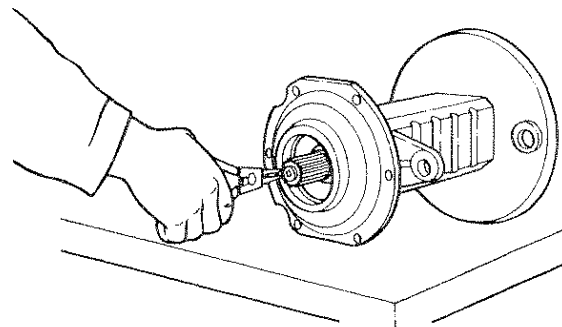

OP.1103

3 - Remove the spring ring and remove the drive sleeve.

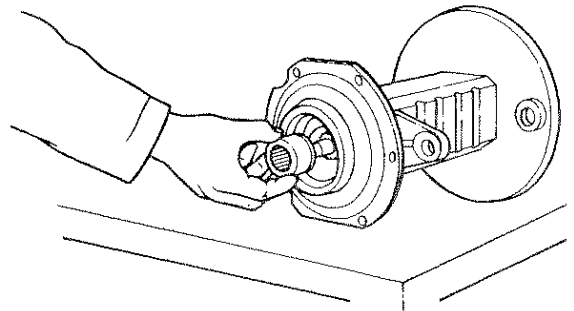

OP.1104

4 - Remove the traction engagement sleeve along with the control pads.

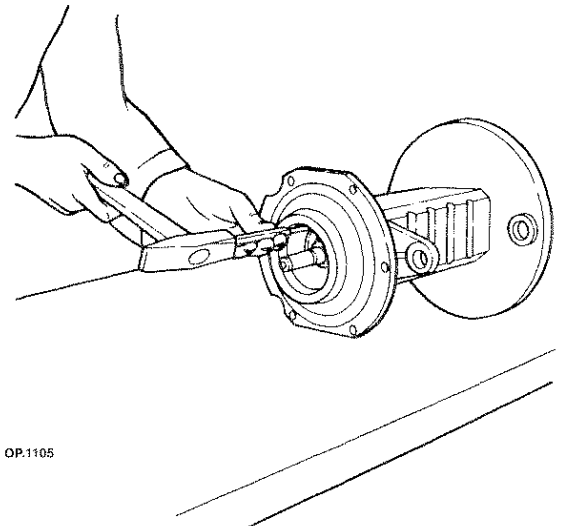

OP.1105

5 - Remove the spring pin and remove the shaft along with the control fork.

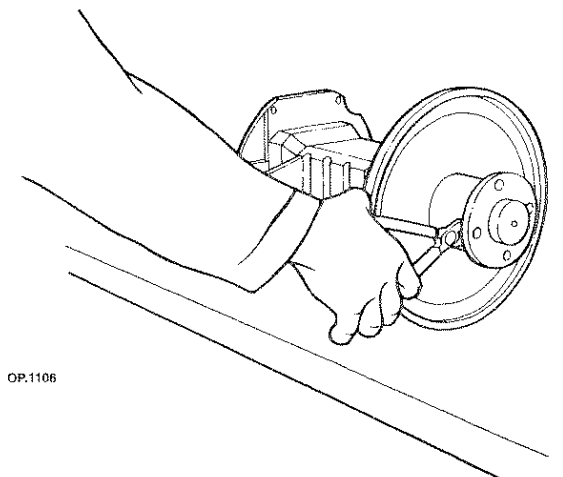

OP.1106

6 - Remove the retainer ring and remove the whole semishaft.

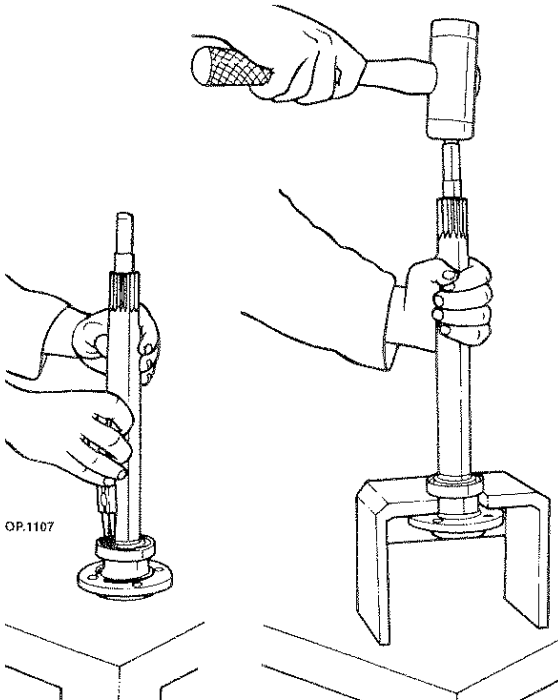

7 - Remove the bearing retainer ring.

8 - Remove the bearing with tool AT 37981316.



WARNING - DANGER



Perform operations by strictly observing accident prevention regulations.
- Use tools to align holes and slots not hands.

Assembly

a - proceed inversely as to the disassembly operations.

b - observe the pictures for the location of the different components.

c - observe the driving torques listed at page 4.

d - Follow the following operations:

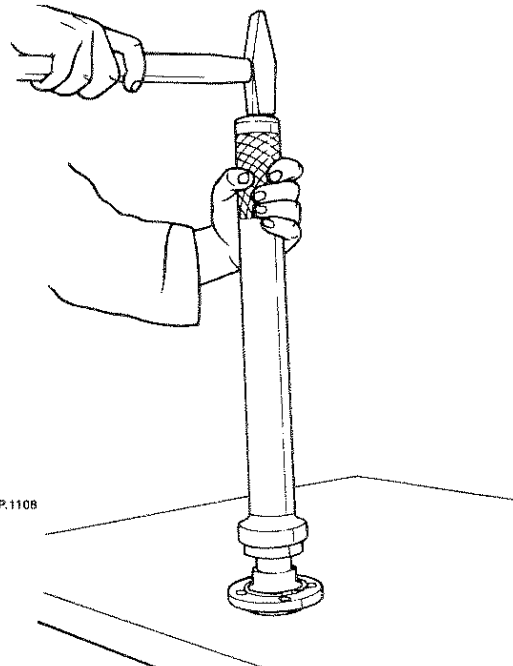

1 - Mount the semishaft bearing using the driver AT 37981092.

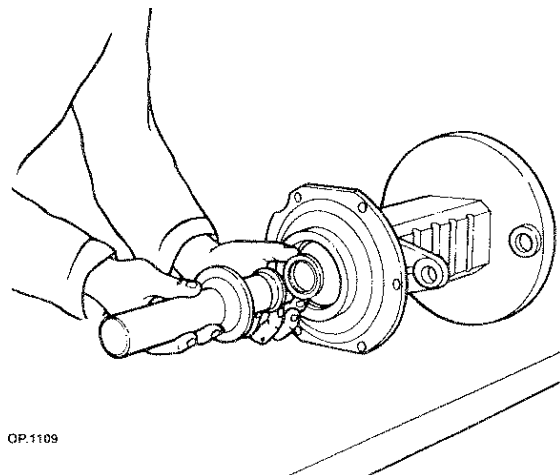

2 - Mount seal using the driver AT 37981329.



WARNING - DANGER



Perform operations by strictly observing accident prevention regulations.
- Do not use gasoline, diesel oil or other flammable liquids to degrease or clean parts but use commercial non-toxic solvents instead.



REAR AXLE

Disconnecting and connecting

A - Tigretac

To have access to the rear axle proceed as follows:

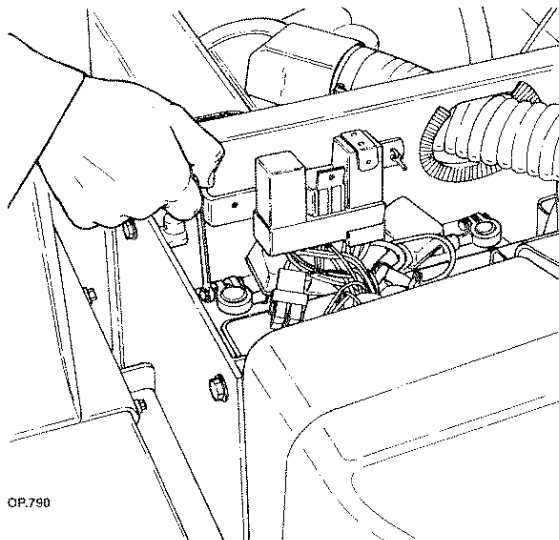

1 - Disconnect the battery wire and insulate it.

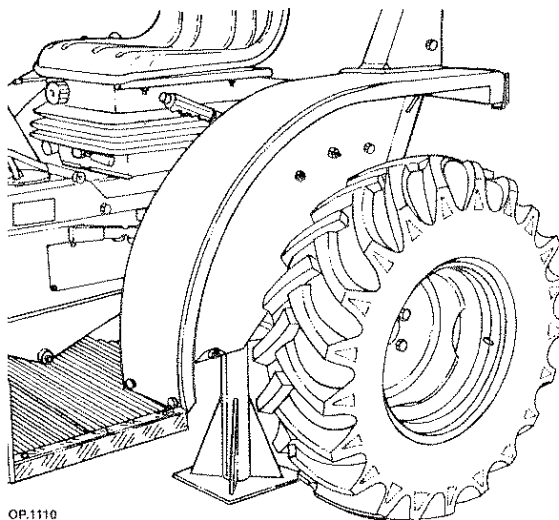

2 - Place a horse underneath the transmission - rear end.

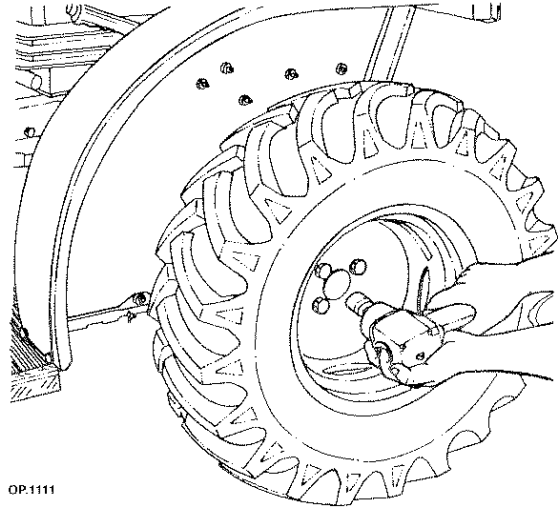

OP.1111

3 - Loosen the screws and remove the rear wheels.

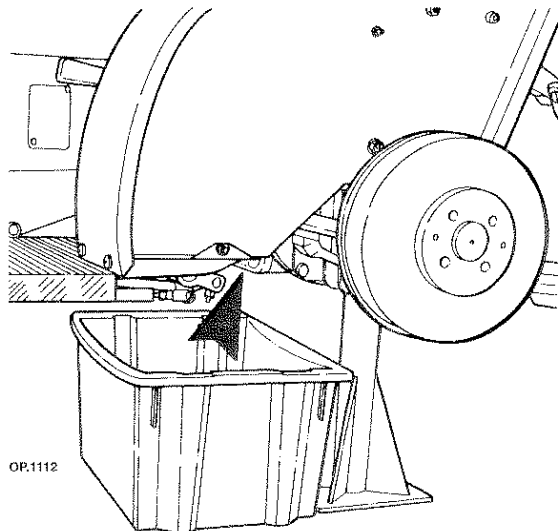

OP.1112

4 - Loosen the plug and drain oil in a special container.

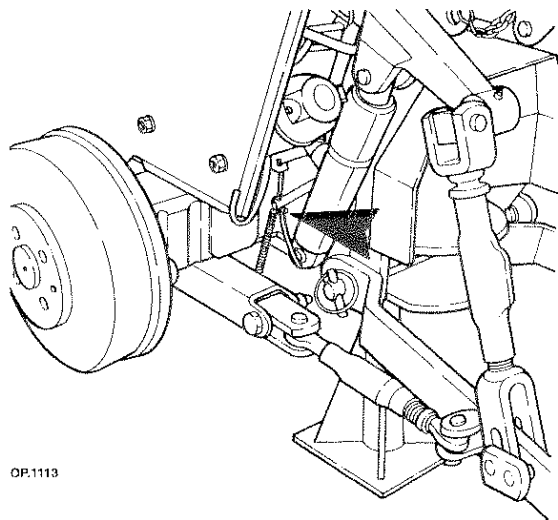

OP.1113

5 - Loosen the traction disengagement wire clamp and remove wire.

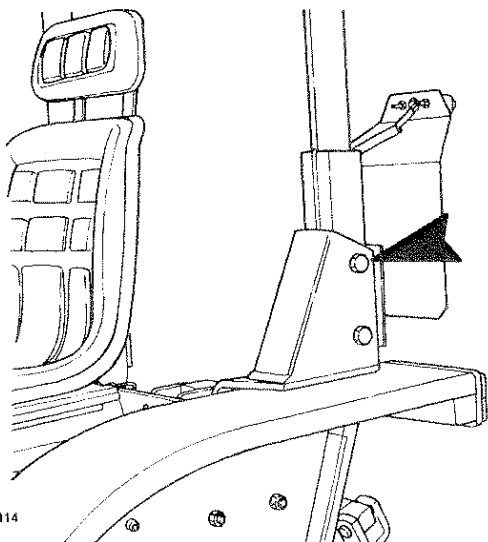

OP.1114

6 - Loosen the screws and remove the number plate support and the roll bar.

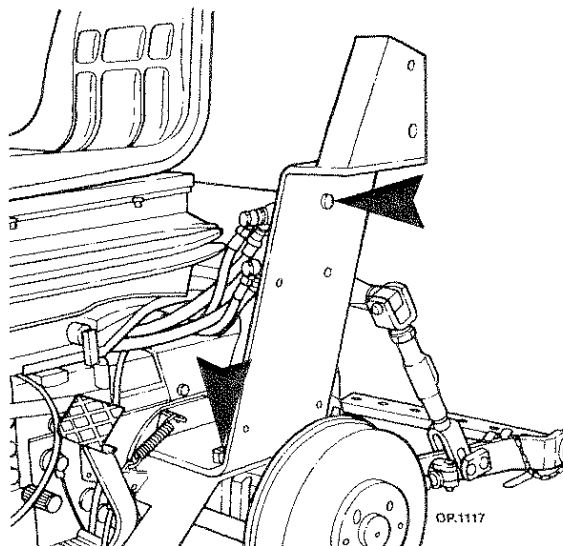

OP.1117

9 - Loosen the screws and remove the roll bar supports.

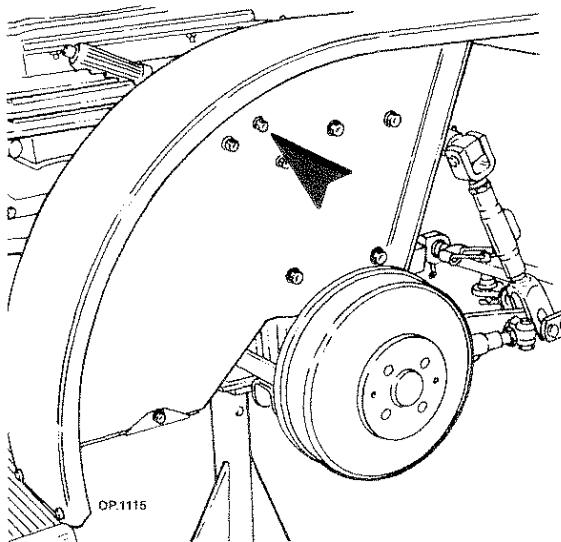

OP.1115

7 - Loosen the screws and remove the hand-brake support.

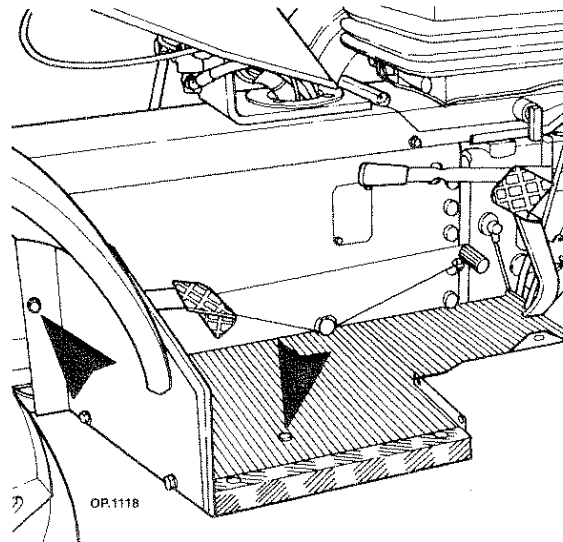

OP.1118

10 - Loosen the screws and remove the footrests.

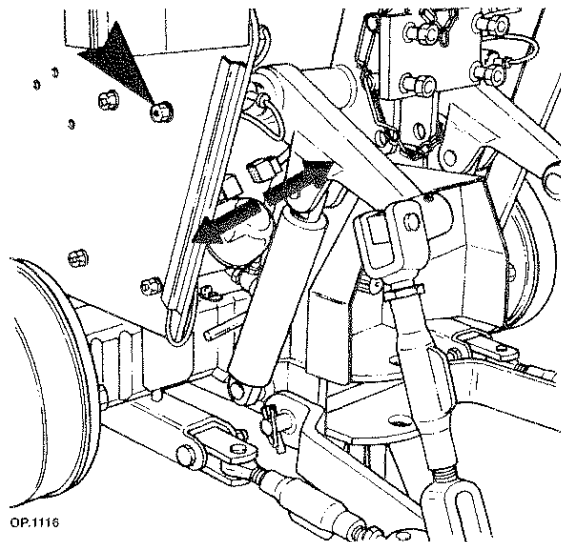

OP.1116

8 - Disconnect the electrical connection on the fenders and loosen the screws and remove the fenders.

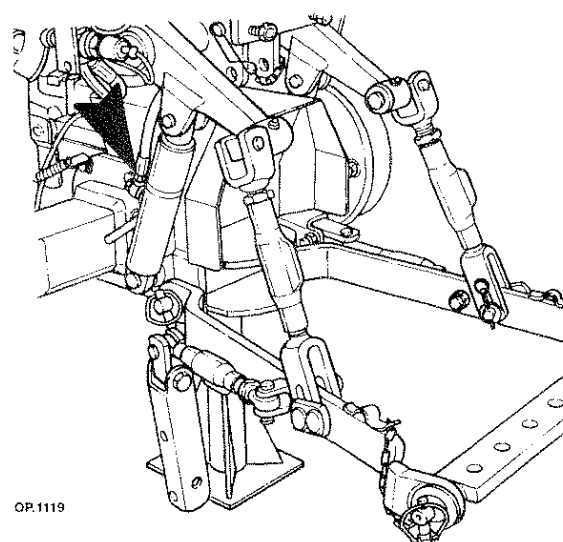

OP.1119

12 - Loosen the unions of the hoisting tubes and plug holes.

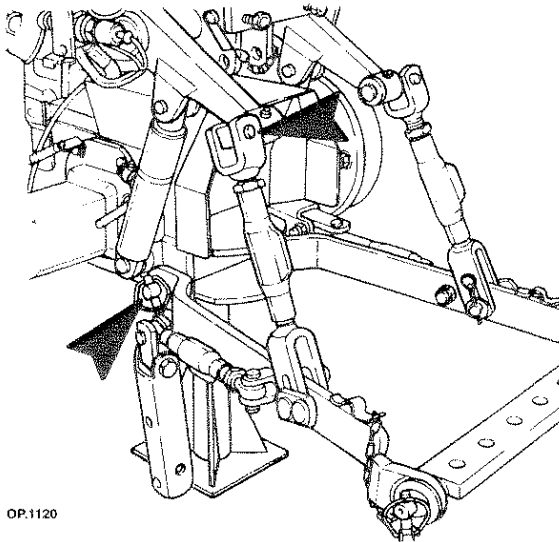

OP.1120

13 - Disconnect the tie-rods and the hoisting bars.

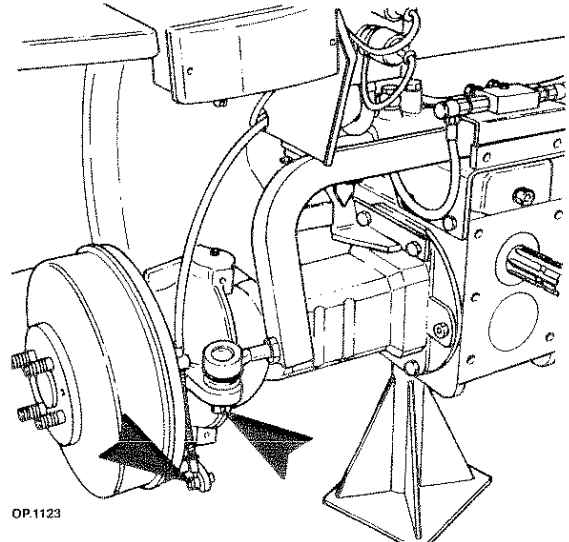

OP.1123

14.2 - Remove the rings and remove the brake wires.

14.3 - Loosen the nuts and remove the bar ends of the steering coupling.

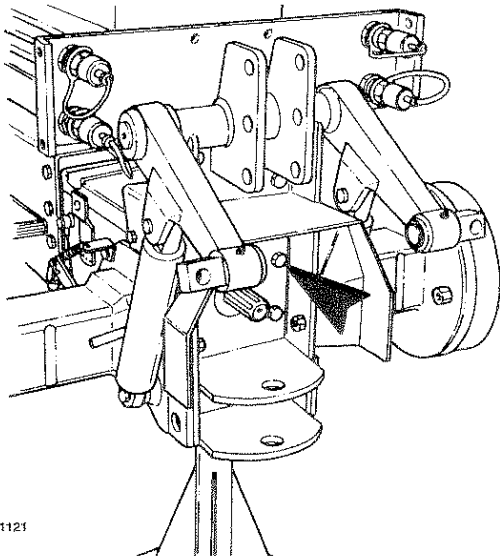

OP.1121

14 - Loosen the screws and remove the rear upper hoisting cover.

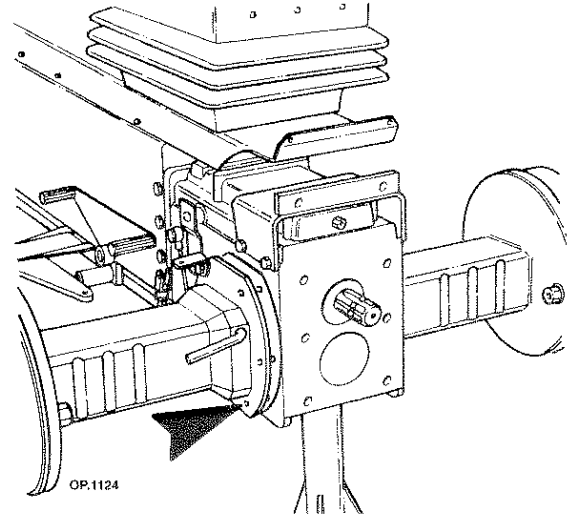

OP.1124

15 - Loosen the axle with differential lock and remove it from the transmission box along with the adjustment shims of the differential box.

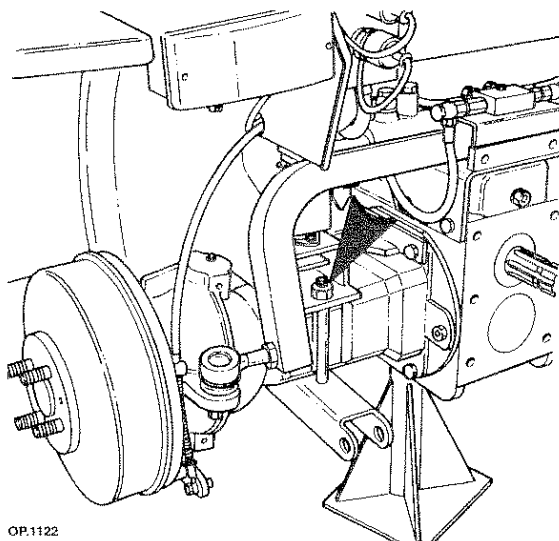

OP.1122

For Tigretac only with frame and 4WS
14.1 - Loosen the bolts and remove the roll bar supports.



WARNING - DANGER



Perform operations by strictly observing accident prevention regulations.
- Use suitable hoisting means.

**WARNING - DANGER**

Keep environment clean. Dispose of waste fluids, used filter cartridges, oils, lubricants and grease cleaners in the most suitable way and in compliance with regulations in force. The collection of waste oils must be performed by authorized plants.

Connection

Proceed to the connection, bearing in mind the following instructions:

a - clean all parts to be mated carefully.

b - apply a 3 mm string of gasket forming compound following the path indicated in the figure.

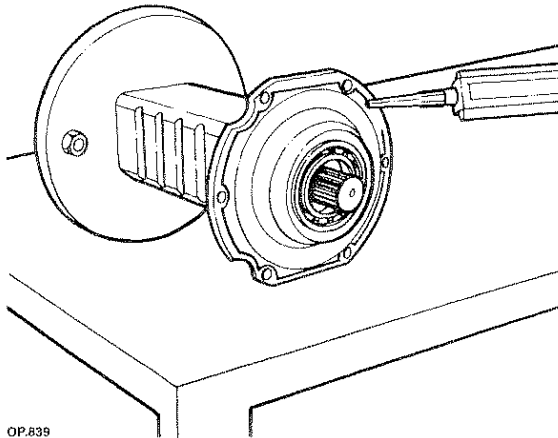

- application of gasket forming compound

c - observe the driving torques listed at page 4

d - proceed inversely as to the disconnection.

e. accurately clean the oil filter and clean all parts of the system that are in contact with the hydraulic oil of the circuit.

REAR AXLE**Disconnecting and connecting****B - Superpark**

To have access to the front axle unit proceed as follows:

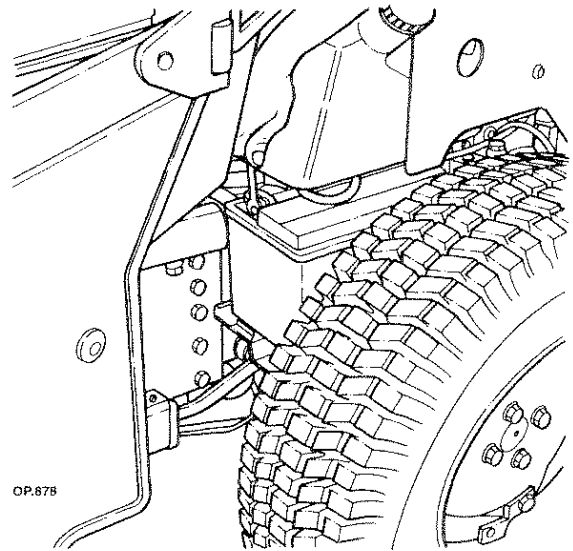

1 - Disconnect the battery wire and insulate it.

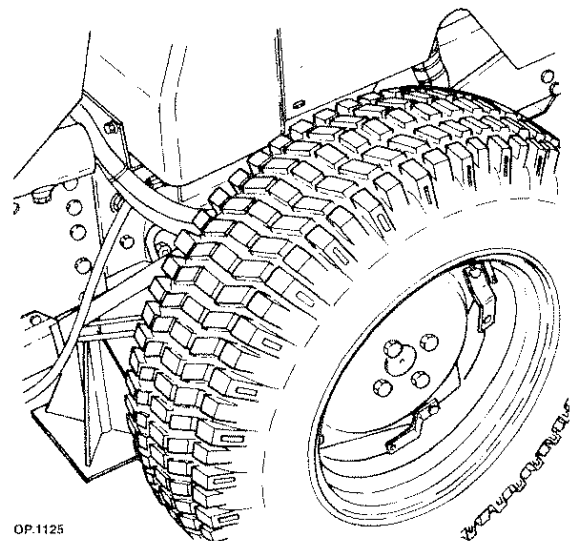

2 - Place a fixed horse underneath the central transmission - rear end.

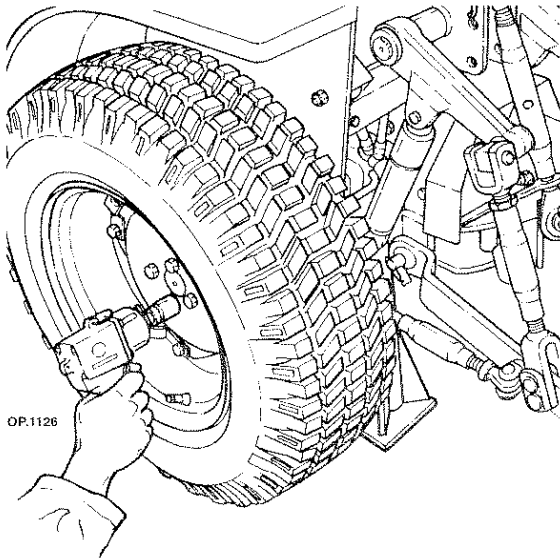

OP.1126

3 - Loosen the screws and remove the wheels.

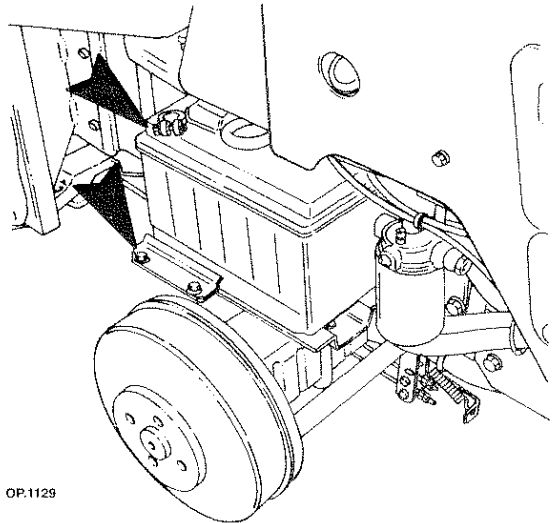

OP.1129

6 - Disconnect the clamp and the support and remove the battery.

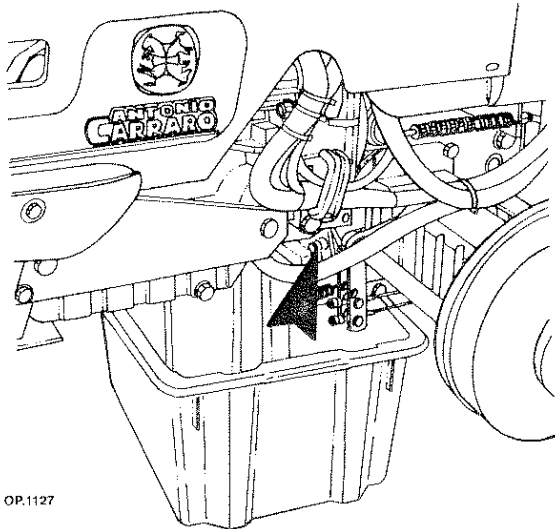

OP.1127

4 - Loosen the screws and remove the cover of the hydraulic oil suction filter and drain oil in a special container.

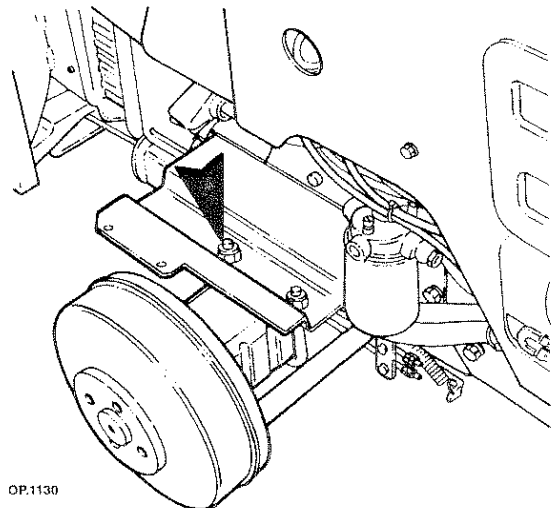

OP.1130

7 - Loosen the nuts and remove the battery supports.

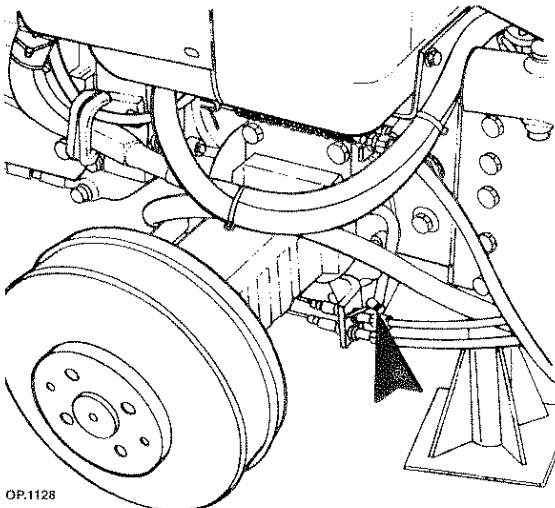

OP.1128

5 - Loosen the clamp and remove the differential locking control wire.

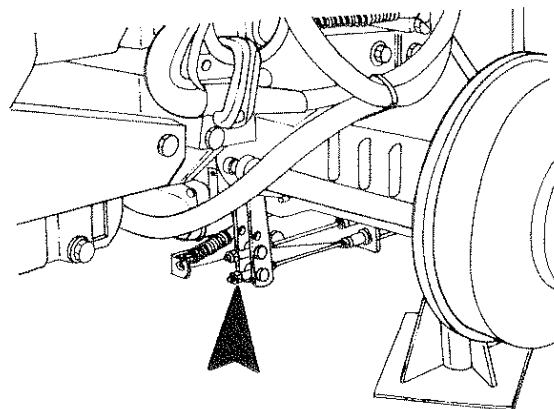

OP.1131

8 - Loosen the nuts and the lock nuts and remove the brake control wires.

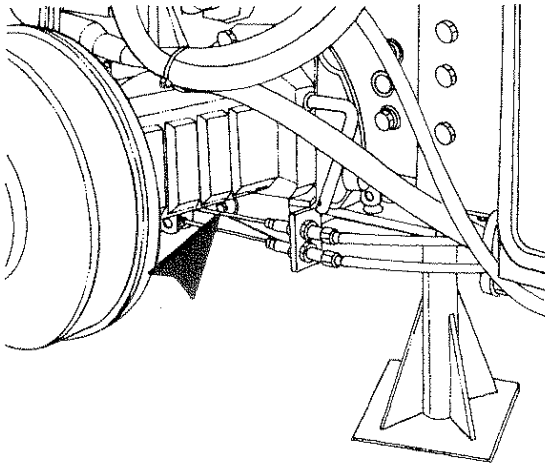

OP.1132

9 - Loosen the screws and remove the supports that clamp the brake control sheath.

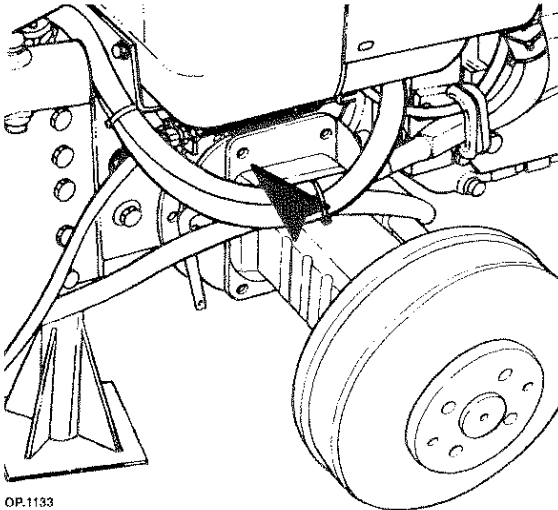

OP.1133

10 - Loosen the screws of the axle with differential lock and remove it from the transmission box along with the differential box adjustment shims.

11 - Loosen the axle screws opposite the differential locking and remove it along with the whole differential unit.

**WARNING - DANGER**

Perform operations by strictly observing accident prevention regulations.

- Wear safety clothing such as, gloves and safety shoes.
- Use suitable hoisting means.

Connection

Proceed to the connection, bearing in mind the following instructions:

a - clean all parts to be mated carefully.

b - apply a 3 mm string of gasket forming compound following the path indicated in the figure.

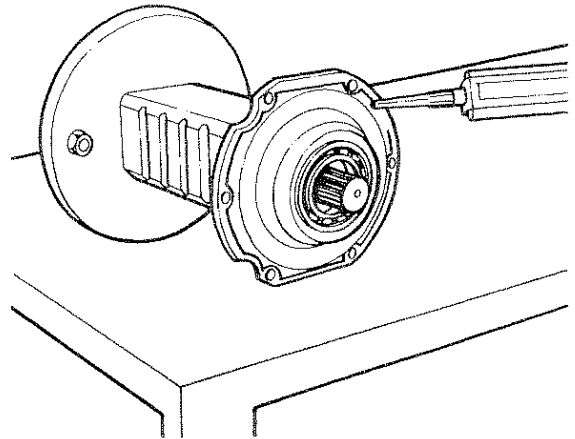

OP.639

- application of gasket forming compound

c - observe the driving torques listed at page 4

d - proceed inversely as to the disconnection.

e - accurately clean the oil filter and clean all parts of the system that are in contact with the hydraulic oil of the circuit.

**WARNING - DANGER**

Keep environment clean. Dispose of waste fluids, used filter cartridges, oils, lubricants and grease cleaners in the most suitable way and in compliance with regulations in force.

The collection of waste oils must be performed by authorized plants.

Disassembly - assembly

Tigretrac - Superpark

Follow the description given for the Superpark front axle.

See page 105-106.

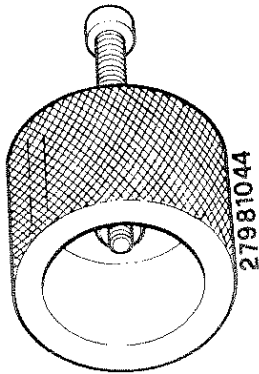

AT.224

1 - Puller for axle pin-bushings

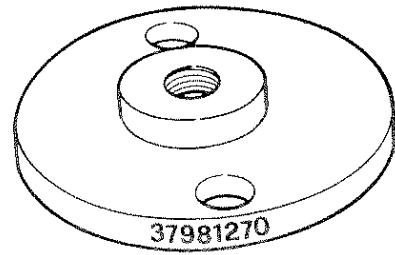

AT.225

4 - Adapter for puller.

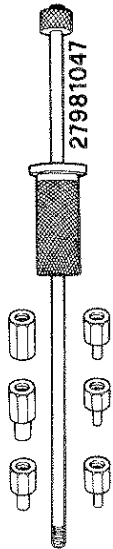

AT.004

2 - Puller for driver with adapter.

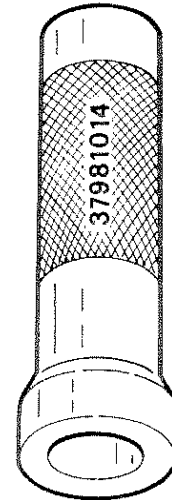

AT.023

5 - Driver for mounting of bearings.

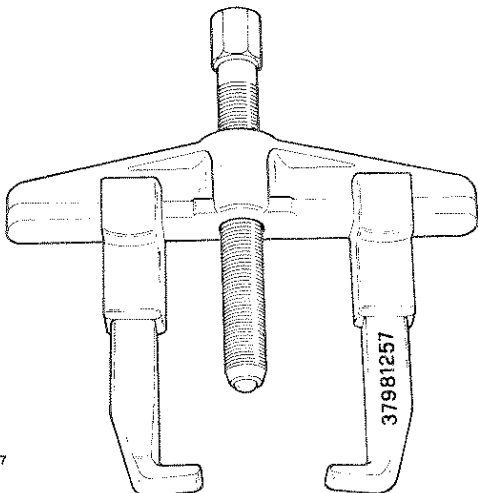

AT.067

3 - Universal puller.

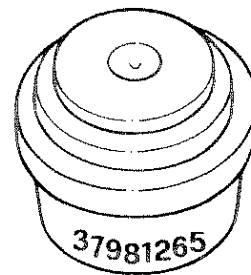

AT.094

6 - Adapter for universal puller.

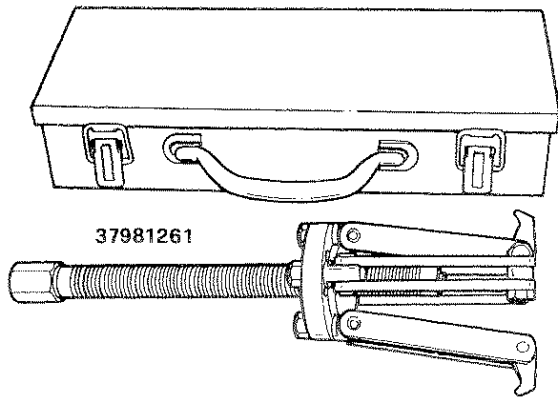

AT.060

7 - Universal puller.

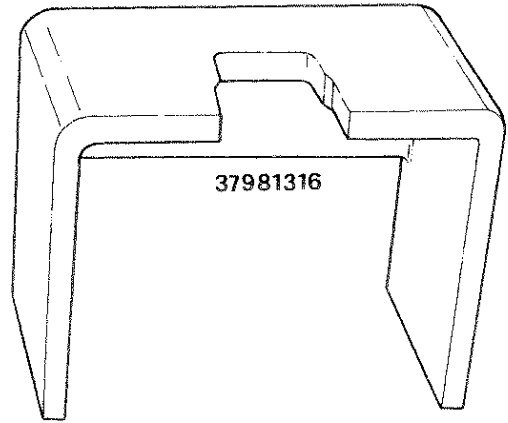

AT.228

10 - Tool for removal of axle shaft bearings.

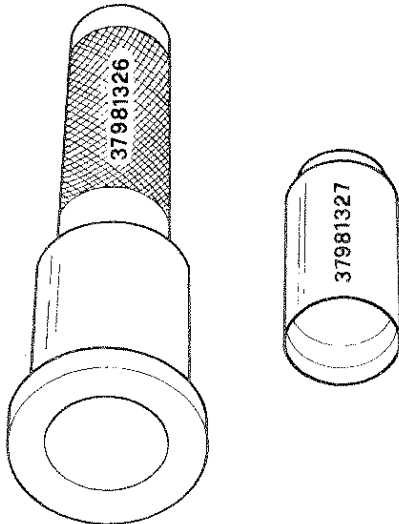

AT.226

8 - Driver and adapter for mounting of packing.



AT.047

11 - Driver for the mounting of the axle shaft bearings.

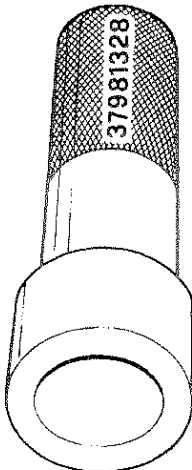

AT.227

9 - Driver for axle shaft bearing.

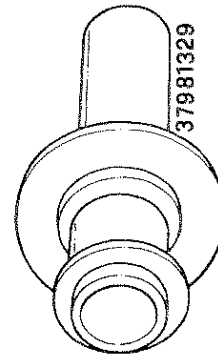

AT.229

12 - Driver for the mounting of the seal ring.

BRAKES

Shoe type brakes operate inside the drums applied to the rear wheel hubs.

Brakes	Brakes			Drum diameter
	Service	Emergency	Parking	
Tigretrac Superpark	Expansion-type with mechanical transmission, controlled by a single pedal.	Expansion-type with mechanical transmission actuated by means of a hand lever with simultaneous reaction on shoes.	It is the same as the emergency device, locked in braking position by means of a non-reversible motion device.	252
Friction material: braking surface $(23 \times 5) \times 4 = 460 \text{ cm}^2$ S.R.				
Brand and type: Ferodo 380 4 F asbestos-free				

Troubleshooting

Troubles	Probable cause	Rimedi
Poor braking	1) Damaged, worn out or excessively smooth friction material 2) Brakes need adjustment	Replace shoes Adjust brakes
Control pedal stroke too long	1) Brakes need adjustment 2) Damaged friction material of the shoes	Adjust Replace shoes
Unbalanced braking	1) Brakes need adjustment 2) Tie-rods need adjustment	Adjust Adjust
Parking brake hard to actuate	1) Rusty connection shaft	Remove parts and grease them
When parking brake is disengaged, the tractor remains locked	1) Hindrance in the return stroke of the tie-rod	Remove hindrances



BRAKES

Disconnecting and connecting

Tigretrac - Superpark

To have access to the brakes proceed as follows:

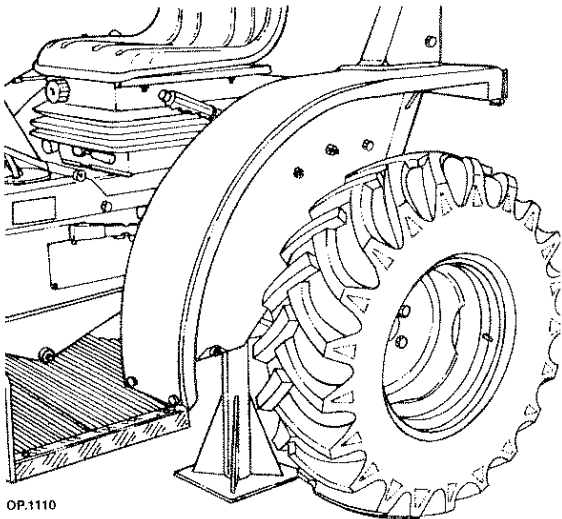

OP.1110

1 - Place a fixed horse underneath the transmission - rear end.

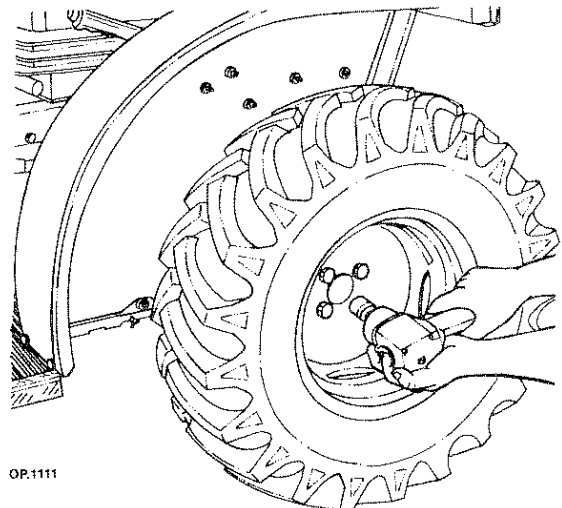

OP.1111

2 - Loosen the screws and remove the rear wheels.

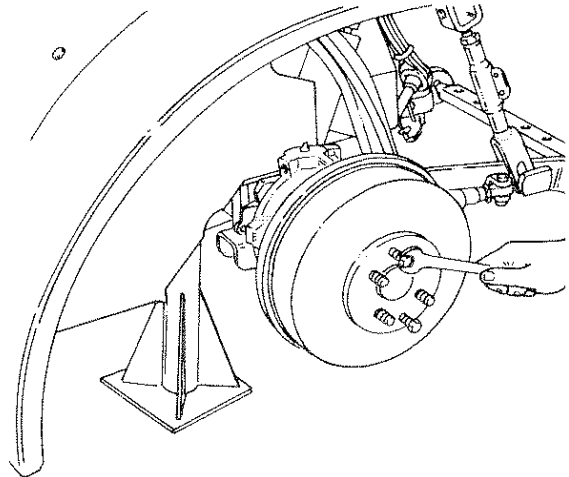

OP.1134

3 - Tighten two screws M 10 and remove the drum.

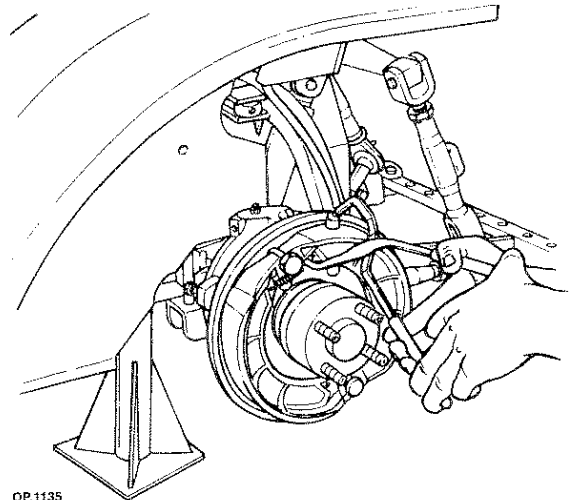

OP.1135

4 - Remove the return springs using the Beta pliers 1471/330.



WARNING - DANGER



Perform operations by strictly observing accident prevention regulations.

- Wear safety clothing such as, gloves and safety shoes.



Connection

Proceed to the connection of the unit considering the following instructions:

- a - Reassemble by proceeding inversely as to the disconnection.
- b - Check that the friction packings are not too worn out and that they are not scratched. If they are, replace them.

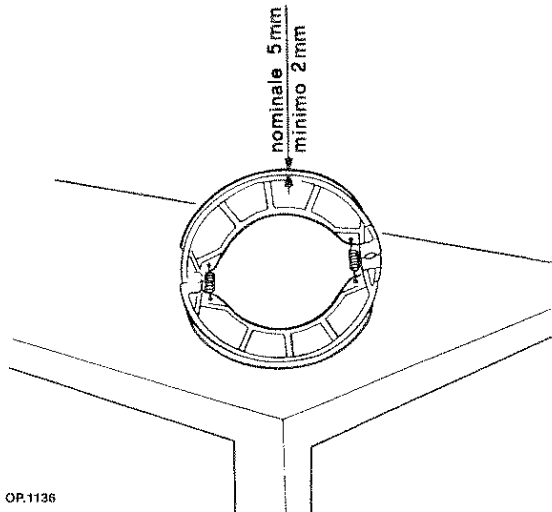

OP.1136

- Checking the friction packing rated dimension.

- c - Accurately clean before assembling the parts and grease the controls (only the commands).

Brake adjustment

To adjust brakes, proceed as follows:

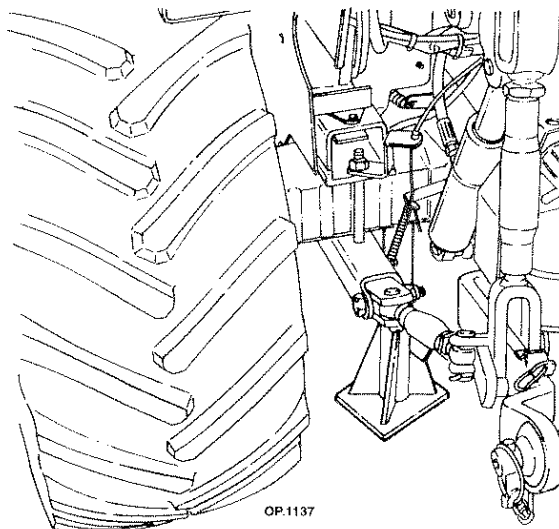

OP.1137

- 1 - Place fixed horses underneath the axles.

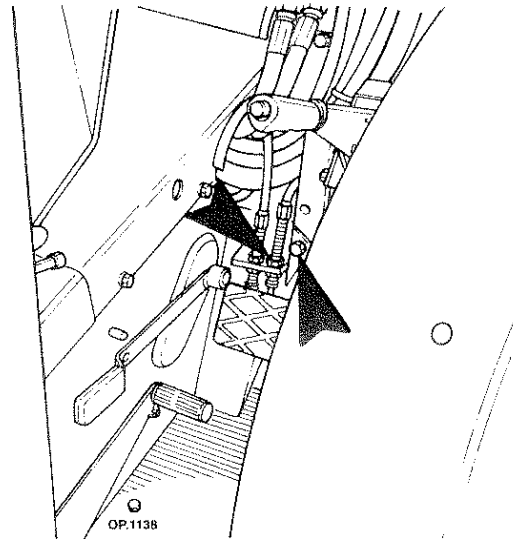

OP.1138

- 2 - Loosen the screws and remove the protection in order to reach the 4WS Tigretrac brake adjustments.
- 3 - Move the shoes towards the drum by means of the tie-rods or adjustment cables.
- 4 - Actuate the foot pedal with a force of 500 - 600 N (50.9 - 61 Kg) so that the shoes perfectly fit as to the drum.
- 5 - Move shoes against the drum by means of the tie-rod or cord for the adjustment of the brakes until shoes slide on the drum.
- 6 - Turn the adjustment in the opposite direction so as to free the shoes from the drum.
- 7 - Correct balancing of the brakes.

Adjustment of brake hand control stroke

To adjust the stroke of the parking brake lever, proceed as follows:

- 1 - Block the parking brake with a force of 400 - 500 N (40.7 - 50.9 Kg.) so controls and brake shoes fit into place.
- 2 - Tighten to loosen the adjustment until the control lever performs 4 - 5 clicks when exerting a force of 400 - 500 N (40.7 - 50.9 Kg).



Hydrostatic steering

The hydrostatic steering gear consists in the capacity of conferring to the wheels an angular displacement proportional to the rotation of the steering wheel making use of a determined quantity of oil delivered by the hydrodrive to the jack (steering cylinder). This means that there are no mechanical connections between the steering wheel and the wheels but only flexible hoses that link the hydrodrive to the steering cylinders.

Hydrodrive

Technical features

	Tigretrac 2500	Tigretrac 3800	Tigretrac 3800 4WS	Superpark 3800
Brand	DANFOSS	DANFOSS	DANFOSS	DANFOSS
Hydrodrive Type	OSPC 50 LS/150-3133	OSPC 50 LS/150-3133	OSPC 100 LS/150-3133	OSPC 100 LS/150-3133
Code	40805006	40805006	40805006	40805006
Priority valve - Priority	OLSA 40/152 B 0119			
Overpressure valve setting	130 Bar	130 Bar	130 Bar	130 Bar
Antishock valve setting	200 Bar	200 Bar	200 Bar	200 Bar
Jack diameter	15/40	15/40	15/40	40
Jack stroke	163	163	163	118
Steering wheel revolution	4.1 3.5	4.1 3.5	4.1 3.5	3
Toe-in		mm 0÷2		



HYDRAULIC DIAGRAM STEERING - SUPERPARK 3800

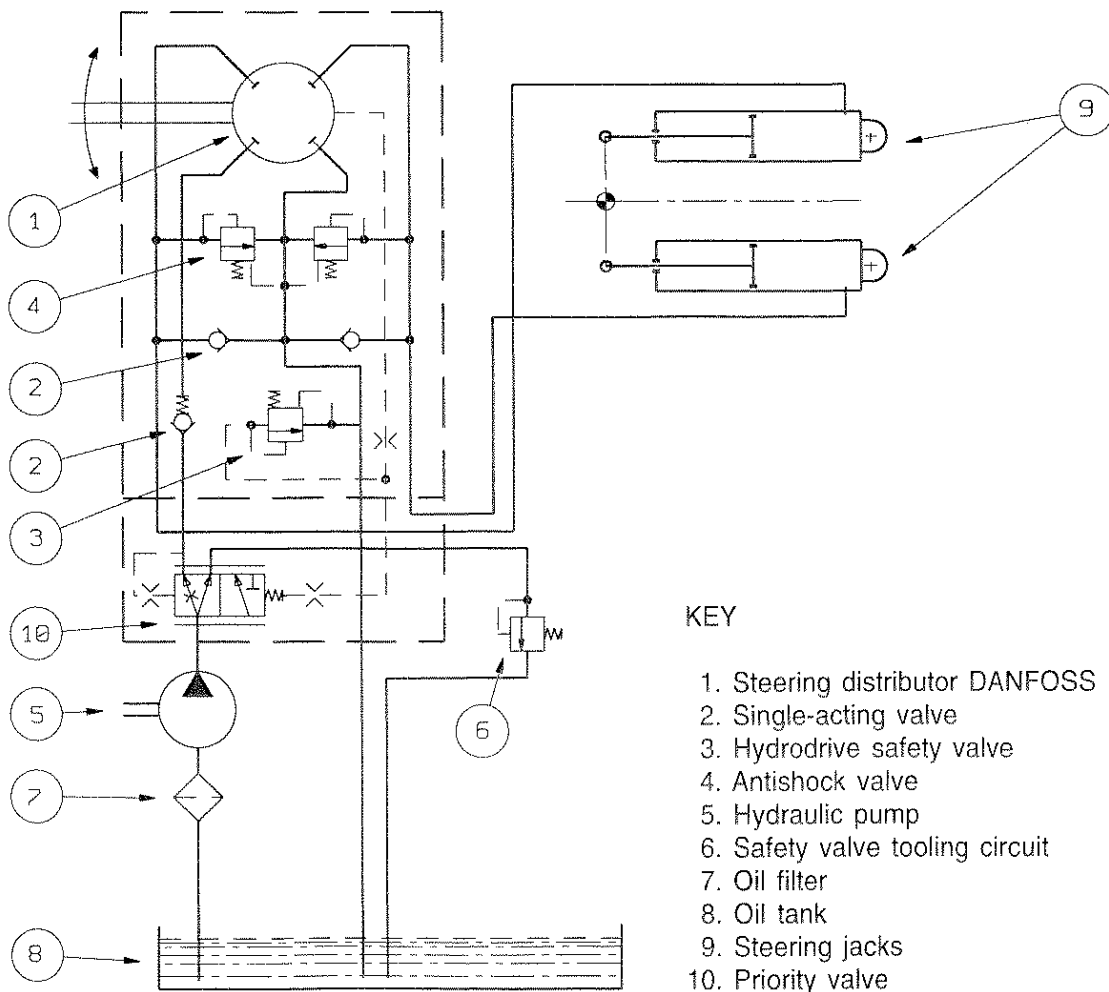
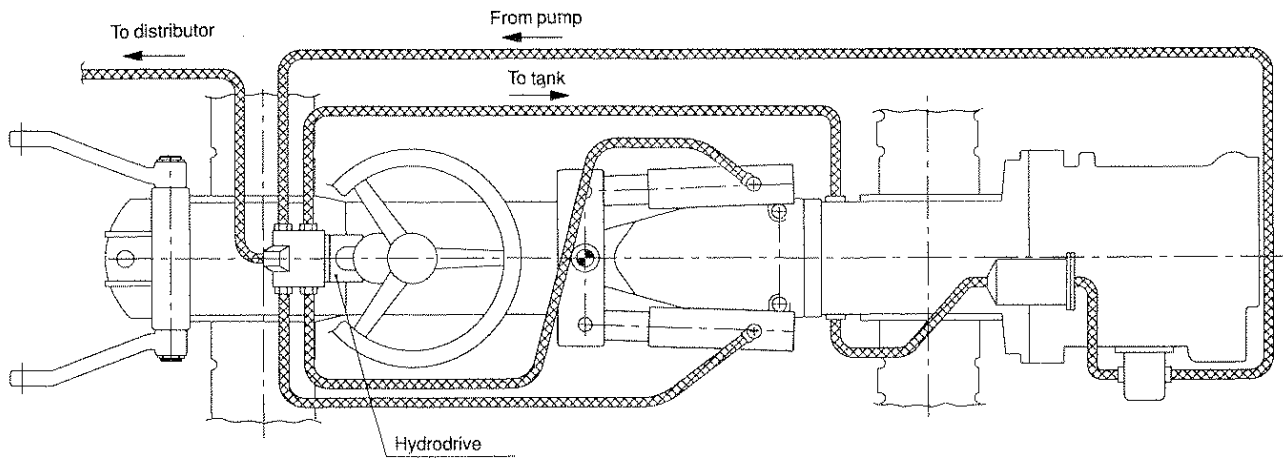



HYDRAULIC DIAGRAM STEERING - TIGRETRAC 3800 4WS

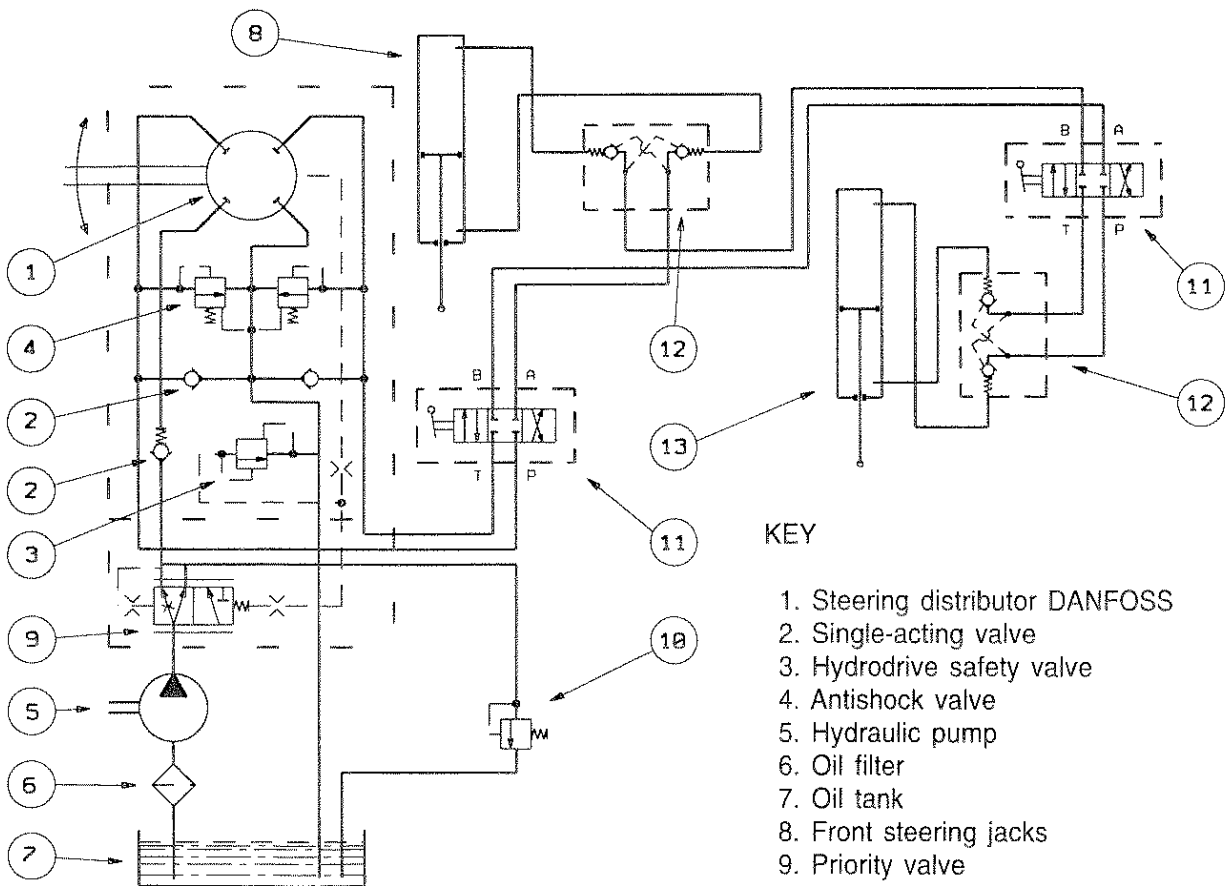
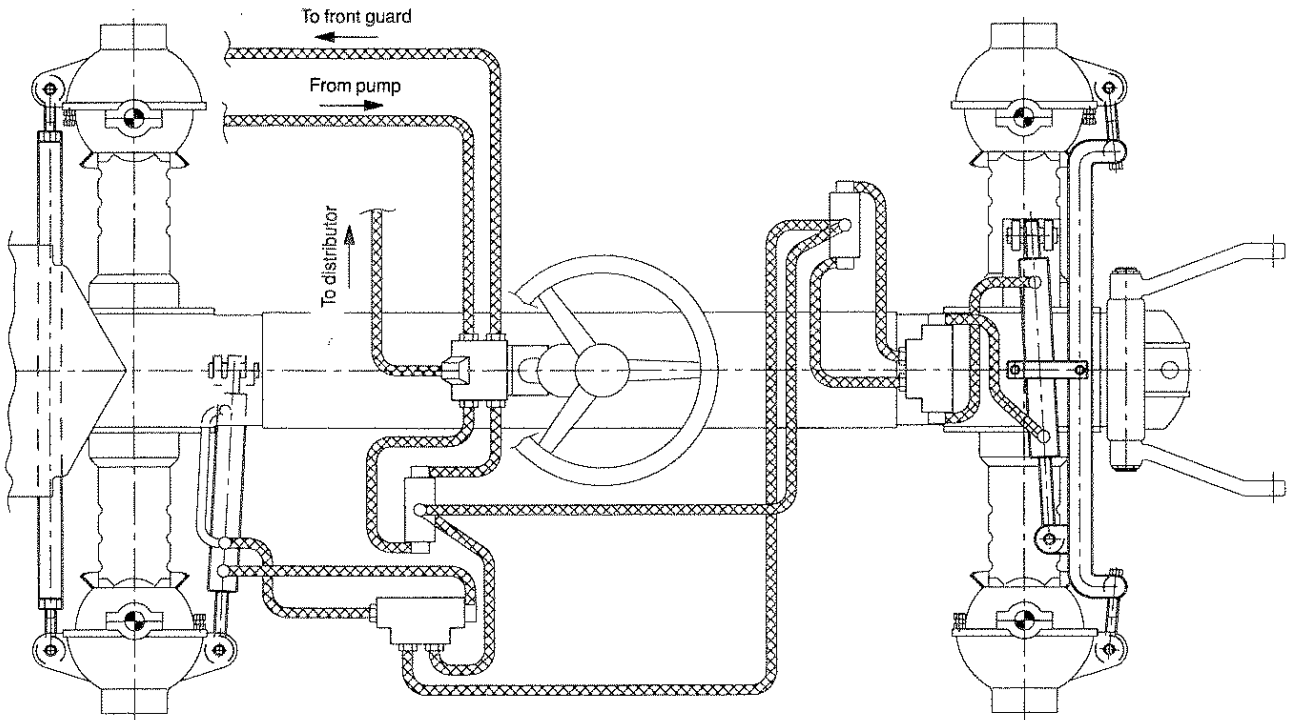

KEY

- 1. Steering distributor DANFOSS
- 2. Single-acting valve
- 3. Hydrodrive safety valve
- 4. Antishock valve
- 5. Hydraulic pump
- 6. Oil filter
- 7. Oil tank
- 8. Front steering jacks
- 9. Priority valve
- 10. Tooling circuit setting valve
- 11. Deviators
- 12. Lock valve
- 13. Rear steering jacks



HYDRAULIC DIAGRAM STEERING - TIGRETRAC 3800

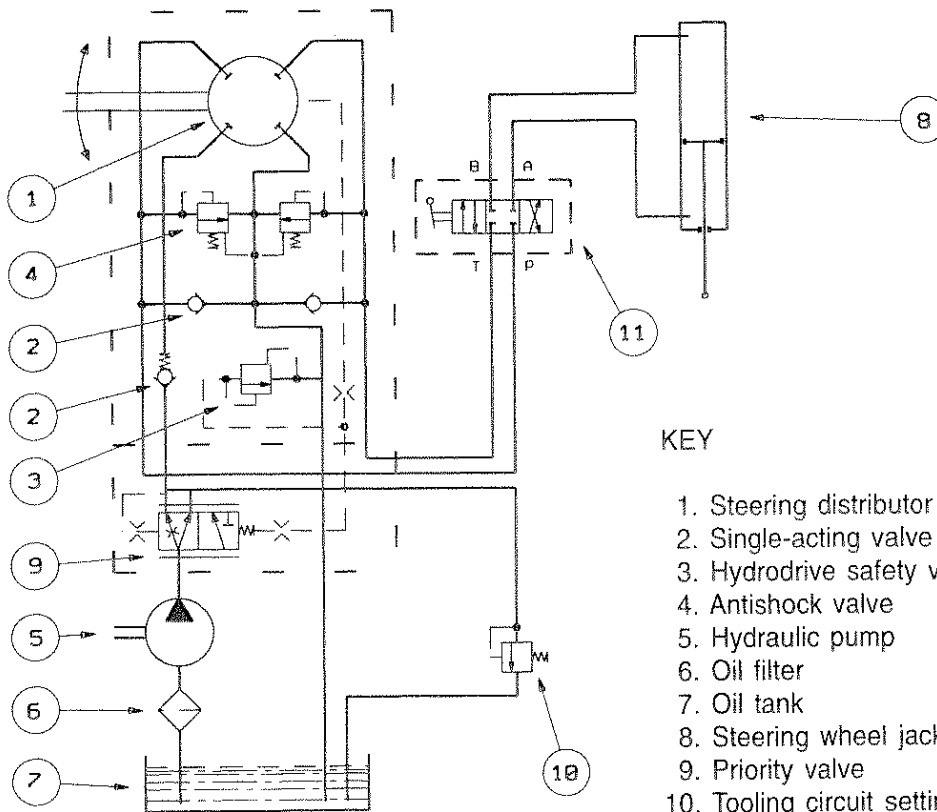
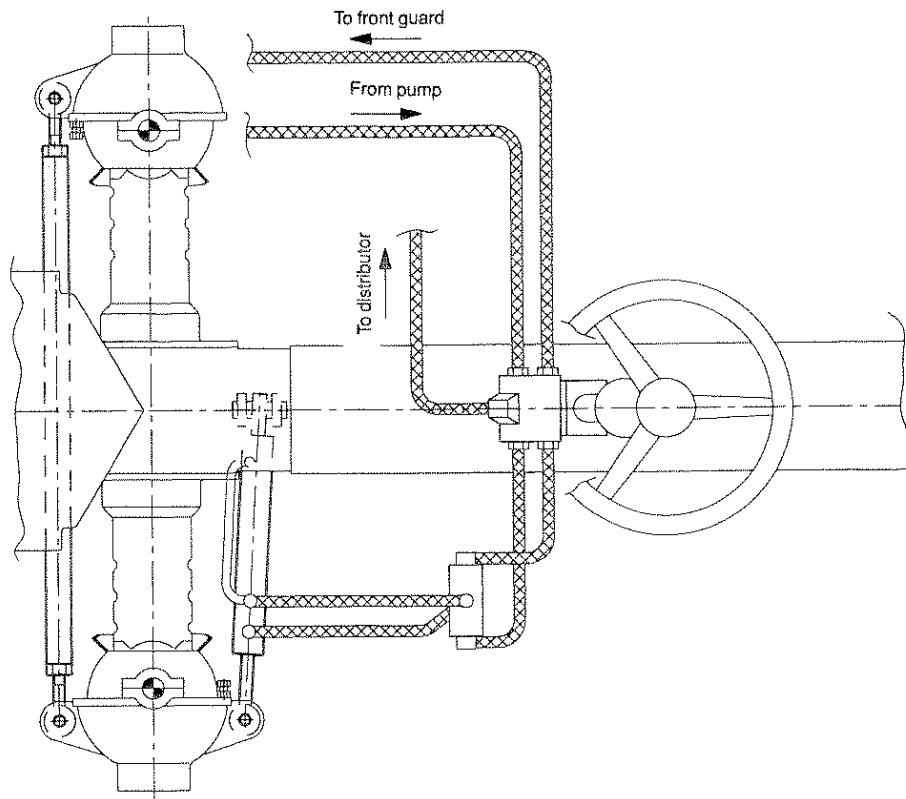

KEY

- 1. Steering distributor DANFOSS
- 2. Single-acting valve
- 3. Hydrodrive safety valve
- 4. Antishock valve
- 5. Hydraulic pump
- 6. Oil filter
- 7. Oil tank
- 8. Steering wheel jacks
- 9. Priority valve
- 10. Tooling circuit setting valve
- 11. Deviator



HYDRODRIVE

Troubleshooting

Trouble	Cause possibili	Rimedi
The steering wheel is hard to turn	1) Faulty hydraulic pump 2) The hydrodrive needs setting 3) Hardening of the steering column due to seizing or oxidation.	Replace the hydraulic pump. Setting of the hydrodrive. Replace or remove cause by lubricating it.
Oil leak in the hydrodrive unit	1) Loose pipes. 2) Faulty washer or O-ring. 3) faulty O-rings.	Tighten unions. Replace washers or packings. Replace packings
The tractor does not follow the steering direction	1) Air in the hydraulic circuit. 2) Worn out seal rings. 3) Cylinder safety or return open valves due to dirt deposit or damaged.	Eliminate causes for air seepage. Replace packings. Eliminate dirt and clean filter or replace the distributor.
The tractor doesn't turn	1) Check the oil level in the front transmission box. 2) Damaged hydraulic pump for hydrodrive and hoisting.	Restore level. Replace pump.

Note: In case of faulty operation of the hydrodrive unit refer to the Danfoss manual.



WARNING - DANGER



Perform operations by strictly observing accident prevention regulations.

- Wear safety clothing such as gloves and safety shoes.

Watch out for shearing, Watch out for squeezing, Watch out for tangling, Watch out for collision, Watch out for projection of fluids at high pressure.

Steering cylinder

Overhauling - replacing the O-ring

TIGRETRAC

To overhaul the steering cylinder, proceed as follows:

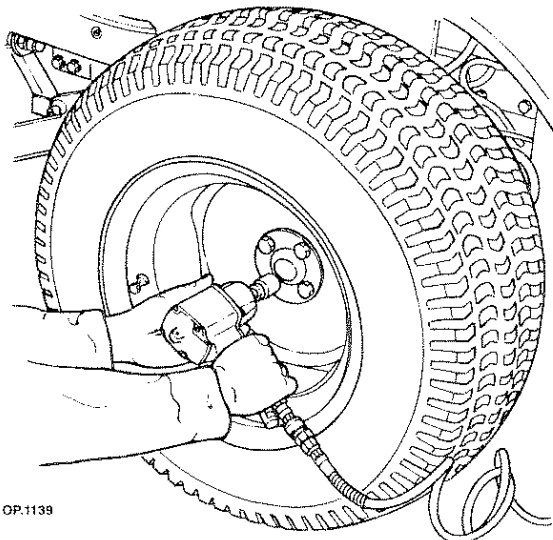

1 - Place a fixed horse underneath the axle, loosen the screws and remove the wheel.

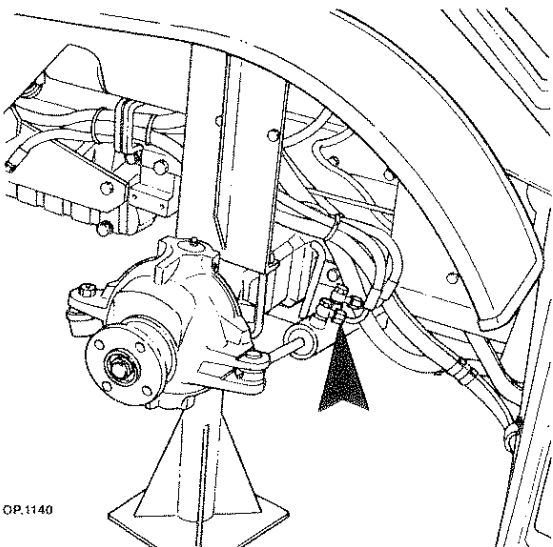

2 - Loosen the unions of the oil tubes and plug the holes with stoppers.

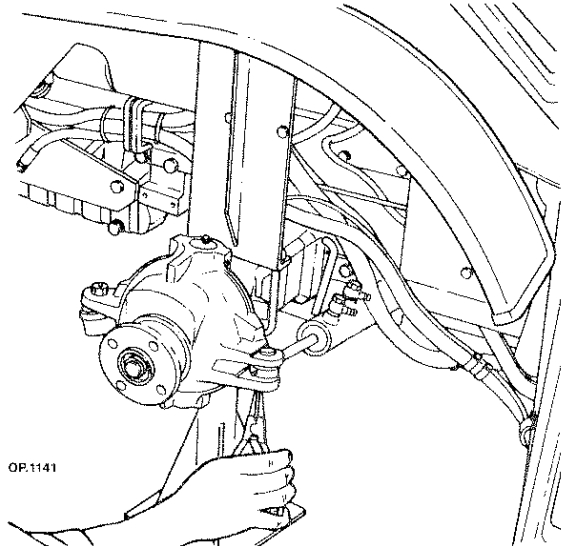

OP.1141

3 - Remove the spring ring and remove the anchoring pin.

4 - Use the puller AT 37981314, remove the steering cylinder pin and remove the whole cylinder.



OP.1171

- Tigretrac hydrodrive cylinder

5 - Remove the spring ring and remove the assembled rod.

6 - Replace the damaged O-ring.

7 - Drain cylinder oil.

8 - Reassemble following the operations below:

a - clean accurately

b - oil O-rings packings, before assembly

c - proceed inversely as to the disassembly operations

**WARNING - DANGER**

Perform operations by strictly observing accident prevention regulations.

- Wear safety clothing such as, gloves and safety shoes.
- Do not align slots with hands but use specific tools instead.

Steering cylinder

Overhauling - replacing the O-ring**SUPERPARK**

To overhaul the steering cylinder, proceed as follows:

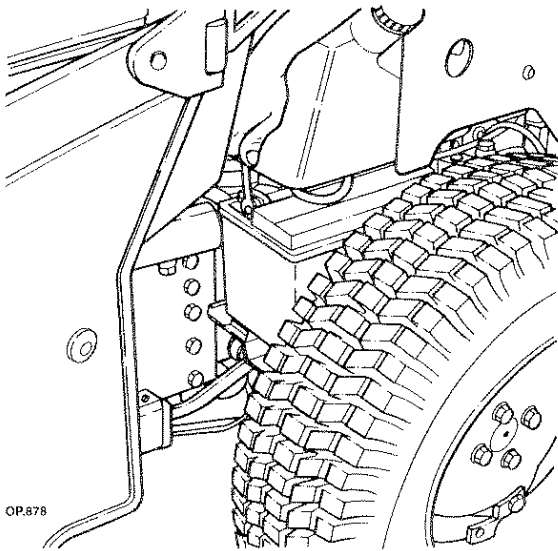

- 1 - Disconnect the positive wire from the battery and insulate it.

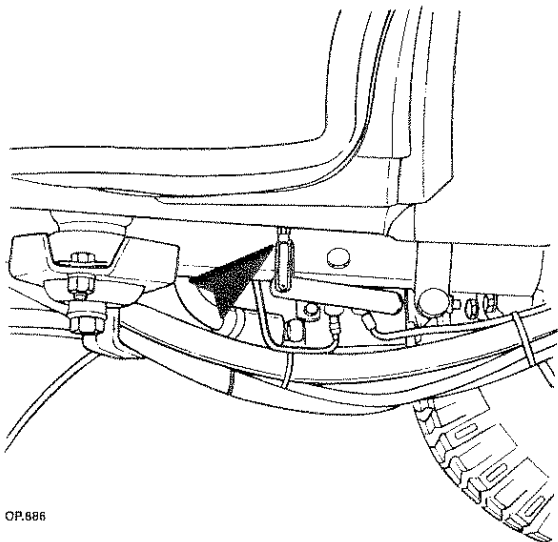

- 2 - Remove the control fork (speed-fix).

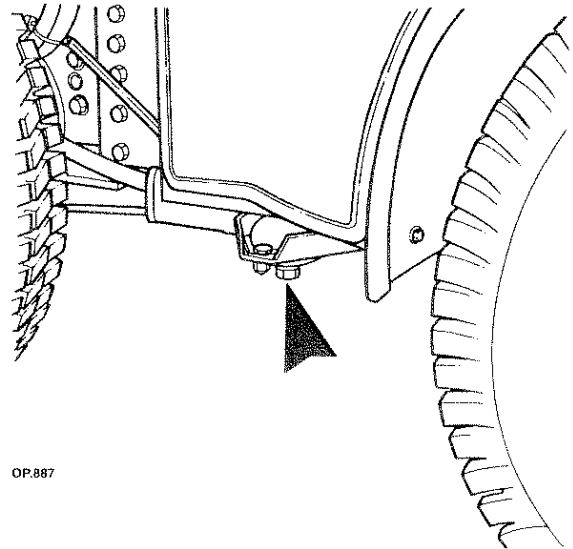

OP.887

- 3 - Loosen the bolts of the rear silent bloc behind the cab.

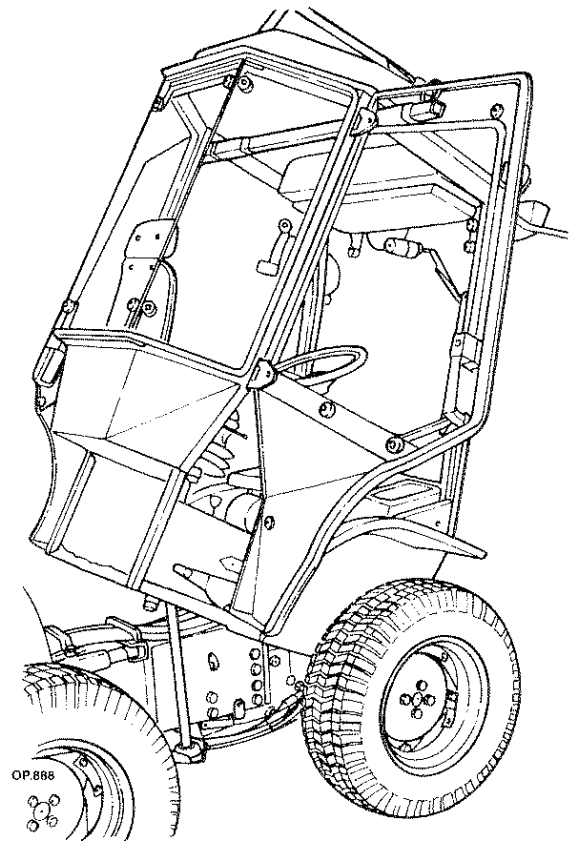

OP.888

- 4 - Sling the cab at the back and hook it to a hoist and lift it high enough to place a safety push rod.

**WARNING - DANGER**

Perform operations by strictly observing accident prevention regulations.

- Use suitable hoisting means.
- Wear gloves to handle metal cords or chains.

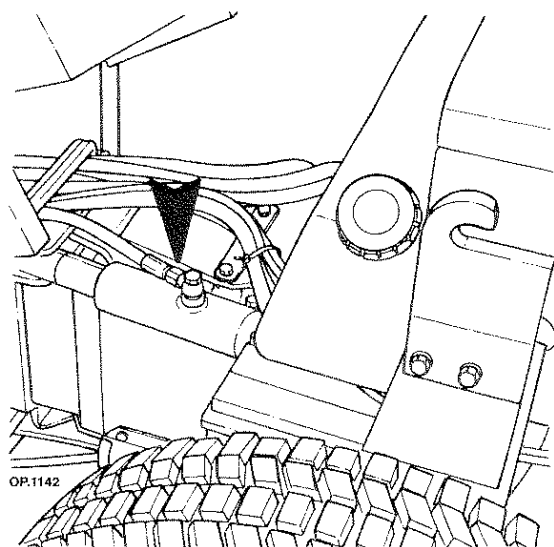

5 - Loosen the union of the hydrodrive cylinder tubes and plug holes with plastic stoppers.

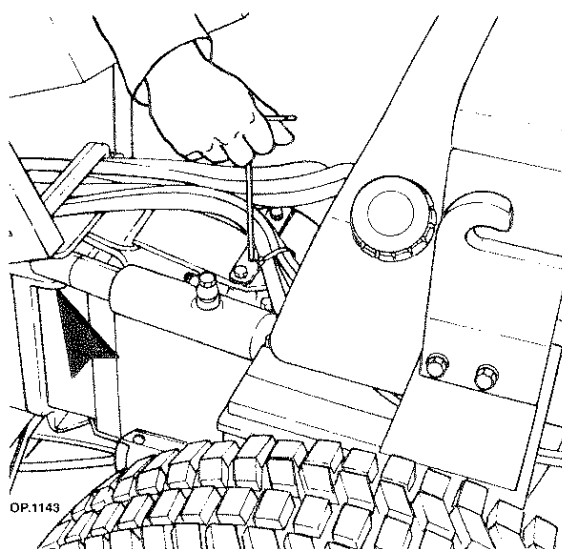

6 - Remove the retainer pins and remove the steering cylinder.

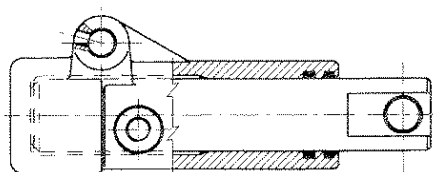

OP.1172

Superpark hydrodrive cylinder

7 - Remove the rod along with the oil remaining in the cylinder.

8 - Replace the damaged O-ring.

9 - Proceed to the assembly, taking into account the following operations:

a - clean accurately

b - oil O-rings packings, before assembly

c - proceed inversely as to the disassembly operations

d - observe the driving torques listed at page 4.



WARNING - DANGER



Keep environment clean. Dispose of waste fluids, used filter cartridges, oils, lubricants and grease cleaners in the most suitable way and in compliance with regulations in force. The collection of waste oils must be performed by authorized plants.

Hydrostatic drive distributor

Disconnecting and connecting

To disconnect the hydrodrive distributor, proceed as follows:

1 - Disconnect the positive wire of the battery and insulate it.

Tigretrac

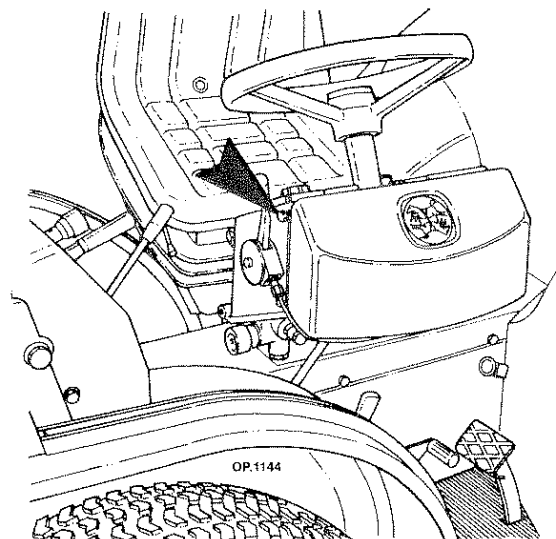

2 - Loosen the screws and remove the cover.

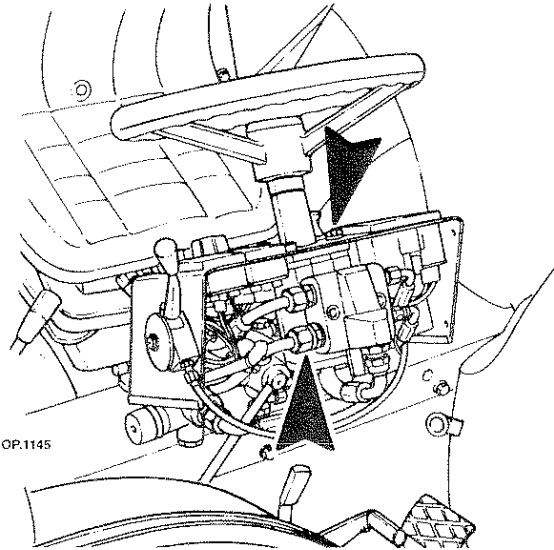

3 - Loosen the five delivery and oil return pipe fittings from the hydrodrive distributors and plug holes with suitable plastic stoppers.

4 - Loosen the fastening screws of the hydrodrive distributor that lead to the steering column.

5 - Reach in for the hydrodrive distributor.



WARNING - DANGER



Perform operations by strictly observing accident prevention regulations.

- Watch out for projection of fluids at high pressure.

Superpark

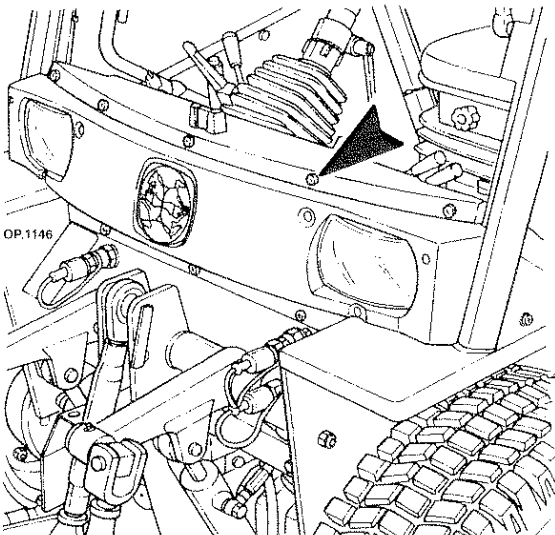

2 - Loosen the screws and remove the dashboard that houses the lights.

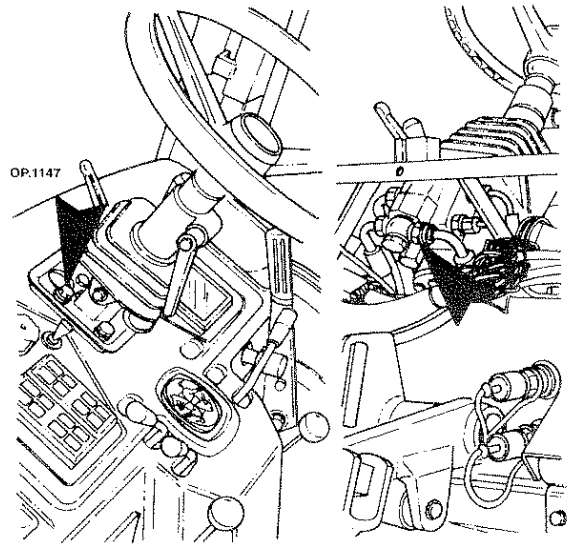

3 - Loosen the five delivery and oil return pipe fittings from the hydrodrive distributors and plug holes with suitable plastic stoppers.

4 - Loosen the fastening screws of the hydrodrive distributor that lead to the steering column.

5 - Reach in for the hydrodrive distributor.

Re-assembly

Hydrostatic drive distributor

Tigretrac - Superpark

4 - Connect the hydrodrive distributor, taking into account the following operations.

a - proceed inversely as to the disconnection operations

b - remember to remove the stoppers

c - observe the driving torques listed at page 4.

Disassembly and assembly

Hydrostatic drive distributors

See Danfoss manual



Hydrodrive overpressure valve control

To check overpressure of the hydrodrive, proceed as follows:

- 1 - Switch off the engine and disconnect one of the oil delivery tube to the cylinder.
- 2 - Replace the above fitting with adapter AT 37981259 and the pressure gauge AT 37981258.

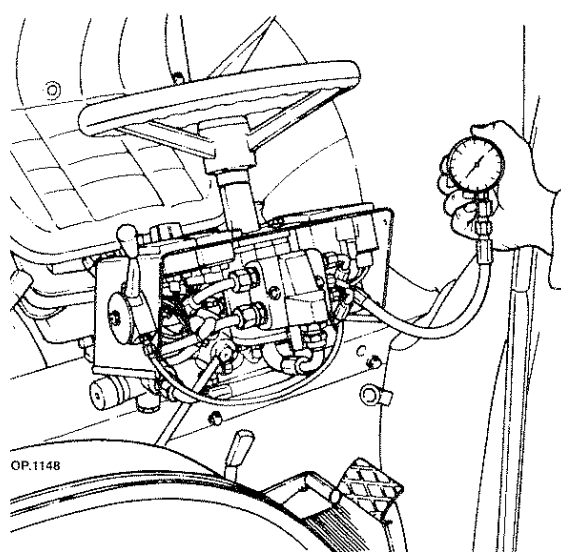

- 3 - Start the engine, accelerate until it reaches 1500 rpm and turn the steering wheel to full steering lock ; in this position the overpressure valve steps in and on the pressure gauge you can read the actual pressure.
- 4 - In case the pressure read differs from the prescribed pressure it is possible to set the valve on the adjustment screw.

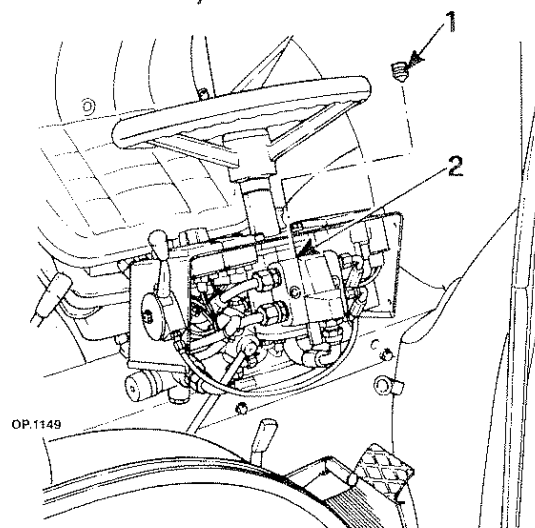

- Pressure adjustment in the hydraulic circuit.

Checking the toe-in of front wheels

Check the toe-in considering that, when wheels are straight they must be parallel to the lengthwise axis of the tractor or with a minimum margin of ± 2 mm.

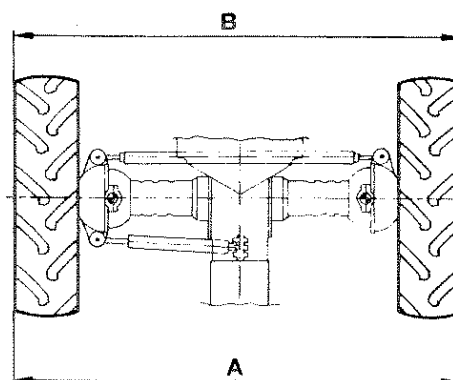

OP.1174

Checking toe-in

To check the exact value of the toe-in, proceed as follows:

- 1 - Position the steering wheel at half stroke.
- 2 - Check that the wheels are parallel to the lengthwise axis of the tractor.
- 3 - Place a ruler on the outer side of the r.h. wheel and one on the l.h. side on the horizontal plane and passing through the centre of the wheel.
- 4 - measure the distance A and the distance B. Make sure that these two measurements are the same or greater up to a maximum of 2 mm and less that a minimum of 2 mm.
- 5 - Correct measurement by operating on the wheel coupling bar.

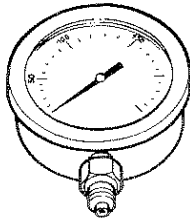

37981258

AT.080

1 - Pressure gauge

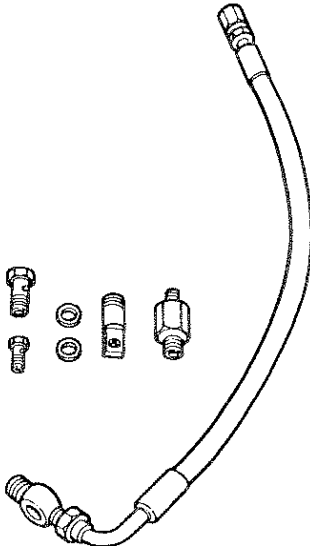

AT.081

37981259

2 - Pressure gauge adapter

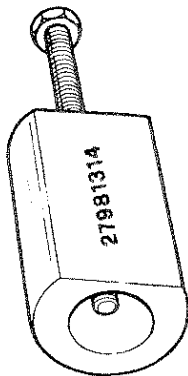

AT.191

3 - Steering cylinder puller.



HYDRAULIC HOISTING DEVICE

The hydraulic hoisting device with controlled positioning and return, controls the traction force, the work position and the dropping speed of the implement.

The standard hydraulic hoisting device is equipped with an open centre distributor.

For both circuits the oil is collected from the front transmission box by a pump and filtered through a recyclable filter then it is pressurized in the circuits.

Technical features

Hydraulic hoisting device

Hoisting device	Standard	Standard	Standard
Type	MD B4 100 M 140 K 01	MD B4 100 M 140 K 01	MD B4 100 M 140 K 01
Brand	DIN OIL IDROIRMA	DIN OIL IDROIRMA	DIN OIL IDROIRMA
Code	4 152 509	4 152 509	4 152 505
Maximum pressure valve setting	110-120 BAR	135 BAR	135 BAR
Type of tractor	Tigretrac 2500	Tigretrac 3800	Superpark 3800

Hydraulic pump

Hydraulic pump	HLPX/X 170 C AM2/24S 100	HLPD/L 211 C
Brand	Lamborghini Idroirma	Lamborghini
Code	2151535	2151536
cm ³ /revolution	7 6,8	11
Type of tractor	Tigretrac 2500	Tigretrac 3800 Superpark 3800

Jack - elevator cylinder

Jack code	23401009
Stroke	146
rod diameter	35
Type of tractor	Tigretrac Superpark

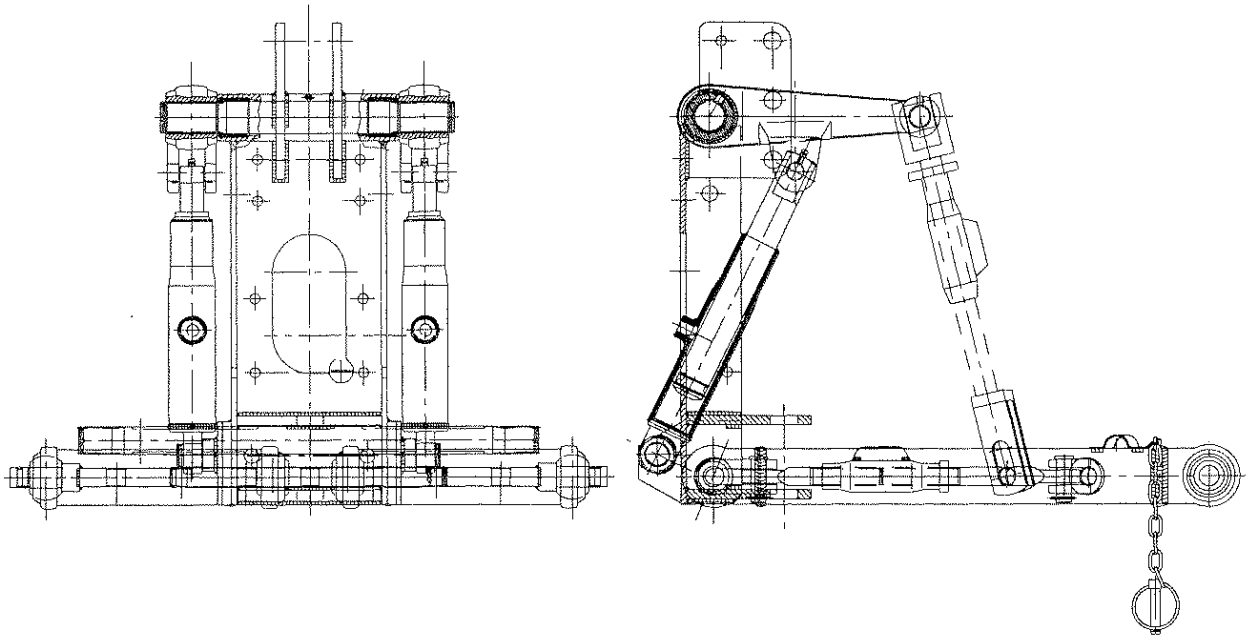

HYDRAULIC SYSTEM

Troubleshooting

Troubles	Possible causes	Solutions
The hoisting does not take place or it takes place too slow.	1) Check the hoisting device is not overloaded. 2) Check proper operation of the pump. 3) Check the setting of the safety valve. 4) Check the oil level. 5) Check the efficiency of the oil filter.	Replace pump. Check the setting. Restore oil level. Clean the oil filter.
The hoisting device does not hoist.	1) Clogged oil filter. 2) Inefficient hydraulic pump. 3) Lack of oil in the tank.	Clean filter. Replace pump. Restore oil level and check for leaks.



SUPERPARK 3800 HYDRAULIC HOISTING DEVICE DIAGRAM

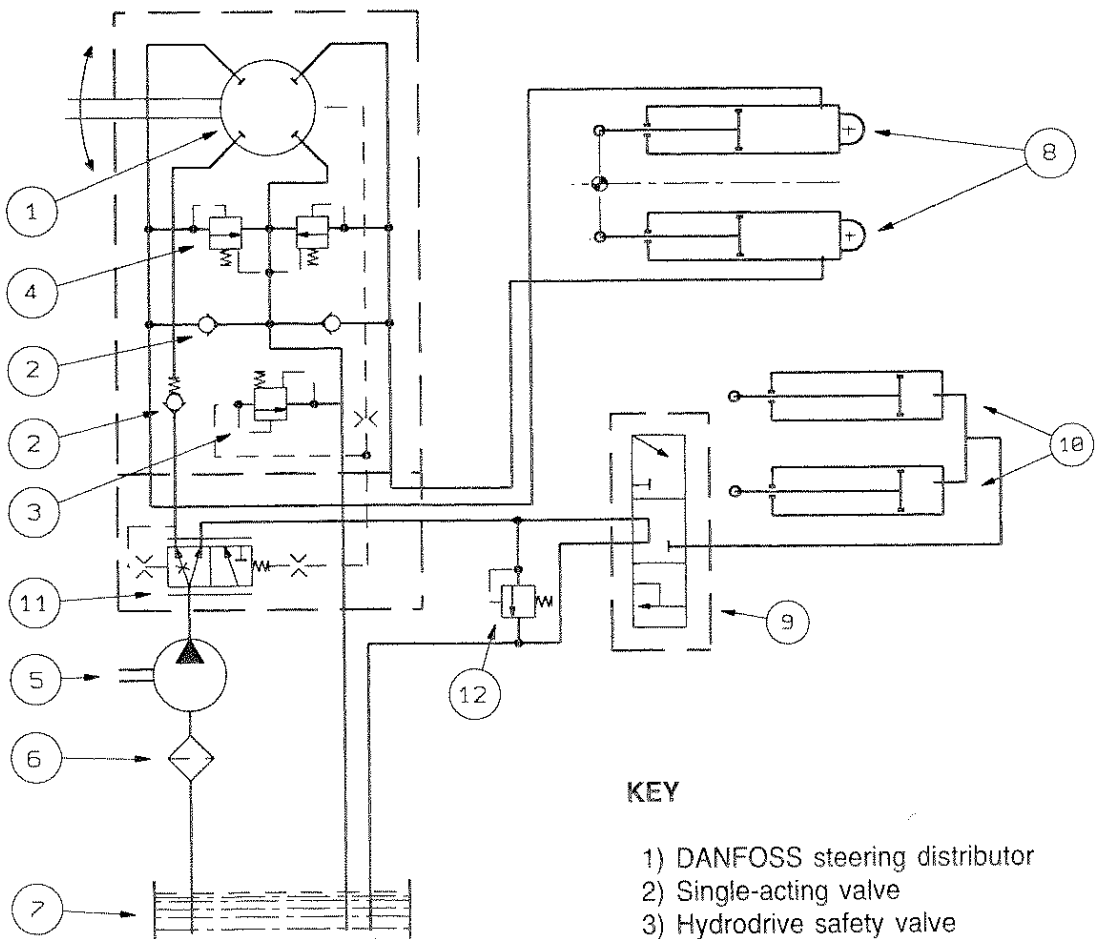
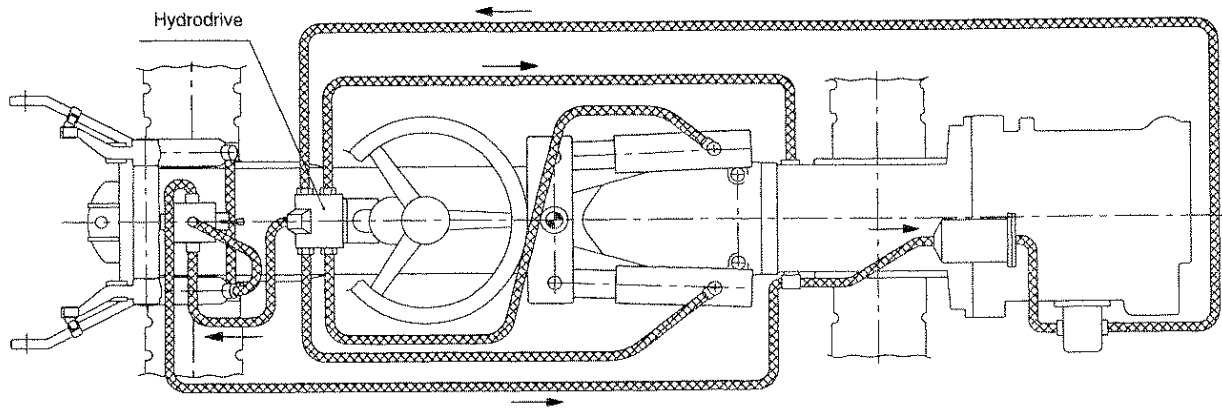

KEY

- 1) DANFOSS steering distributor
- 2) Single-acting valve
- 3) Hydrodrive safety valve
- 4) Antishock valve
- 5) Hydraulic pump
- 6) Oil filter
- 7) Oil tank
- 8) Steering jack
- 9) Standard hoisting device distributor
- 10) Hoisting device jack
- 11) Priority valve
- 12) Equipment circuit safety valve



TIGRETRAC 3800 HYDRAULIC HOISTING DEVICE DIAGRAM

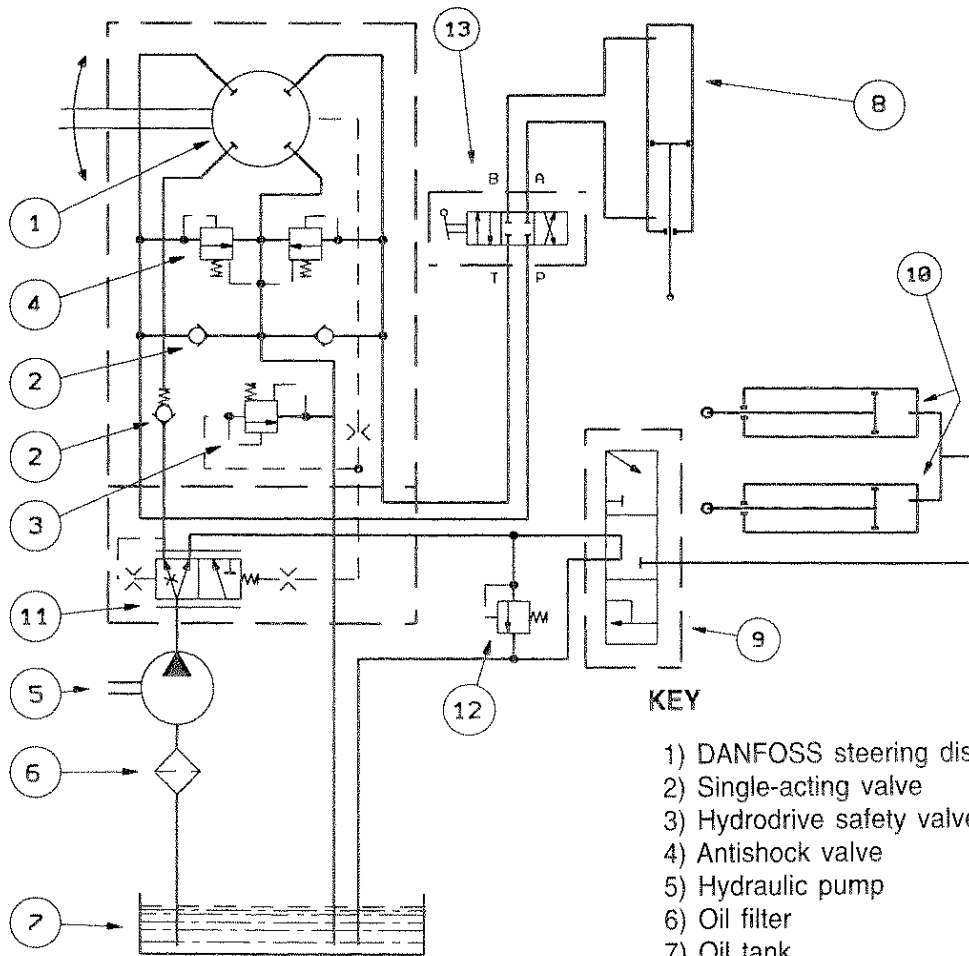
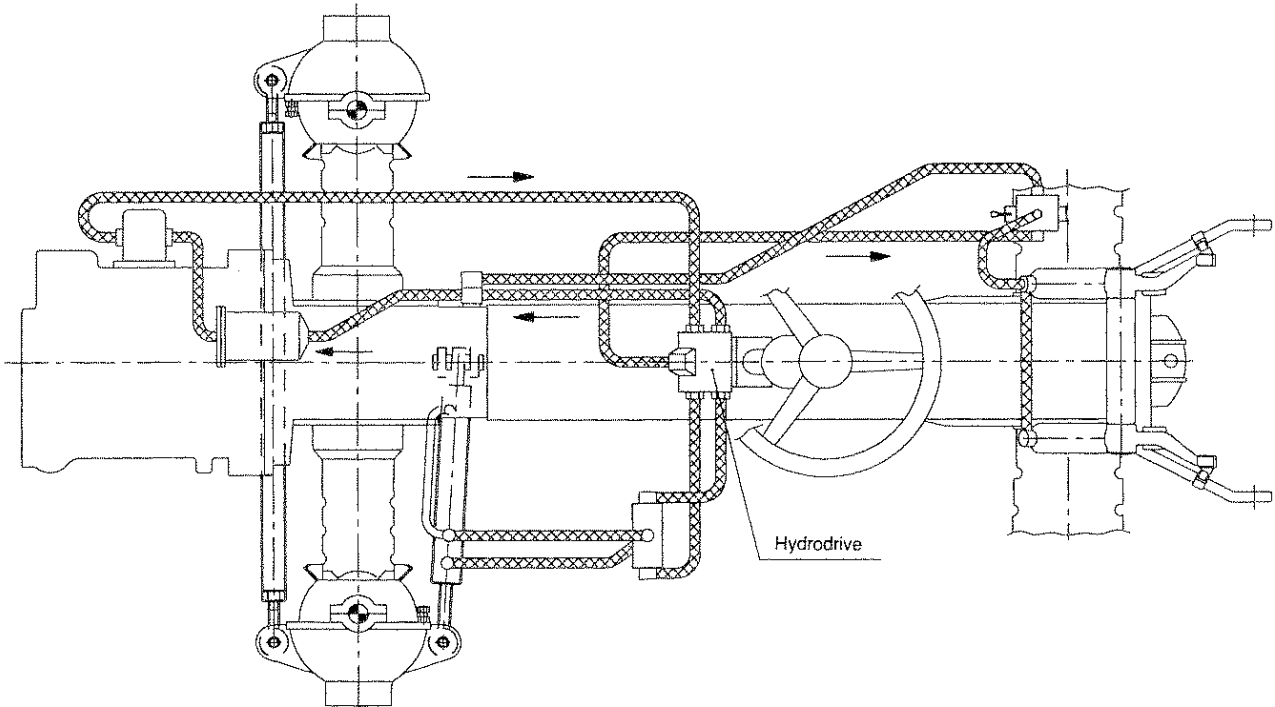

KEY

- 1) DANFOSS steering distributor
- 2) Single-acting valve
- 3) Hydrodrive safety valve
- 4) Antishock valve
- 5) Hydraulic pump
- 6) Oil filter
- 7) Oil tank
- 8) Steering jack
- 9) Standard hoisting device distributor
- 10) Hoisting device jack
- 11) Priority valve
- 12) Equipment circuit safety valve
- 13) Deviator



WARNING - DANGER



Keep environment clean. Dispose of waste fluids, used filter cartridges, oils, lubricants and grease cleaners in the most suitable way and in compliance with regulations in force. The collection of waste oils must be performed by authorized plants.

HOISTING DISTRIBUTOR

Disconnecting - Connecting

To disconnect the distributor of the hoisting device, proceed as follows:

Tigretrac

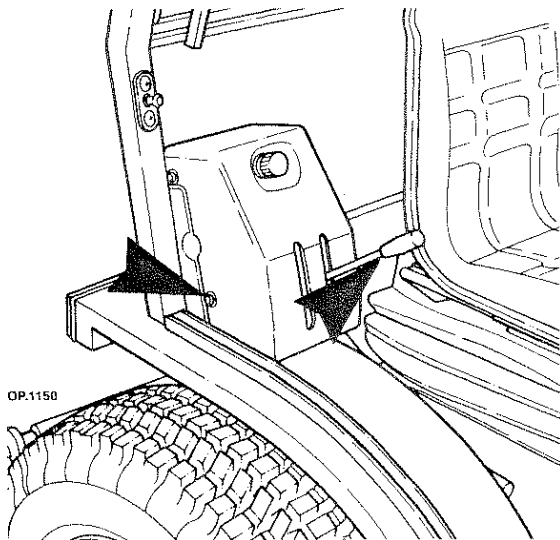

1 - Loosen the screws and remove the protections of the distributor and remove the distributor lever knobs.

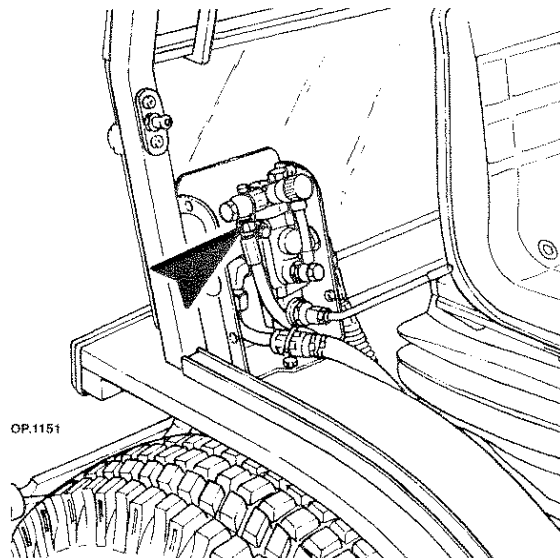

2 - Loosen the oil delivery unions and plug holes with stoppers.

OP.1152

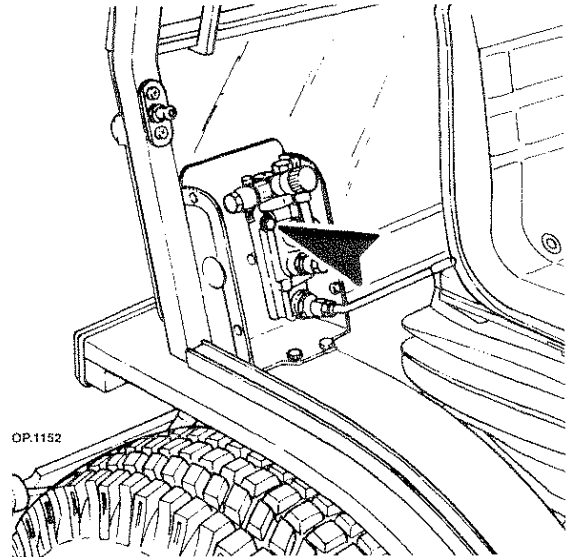

3 - Loosen the screws fastening the hoisting distributor.

4 - Take the hoisting distributor out.



WARNING - DANGER



Perform operations by strictly observing accident prevention regulations.
- Watch out for projection of fluids at high pressure.

Superpark

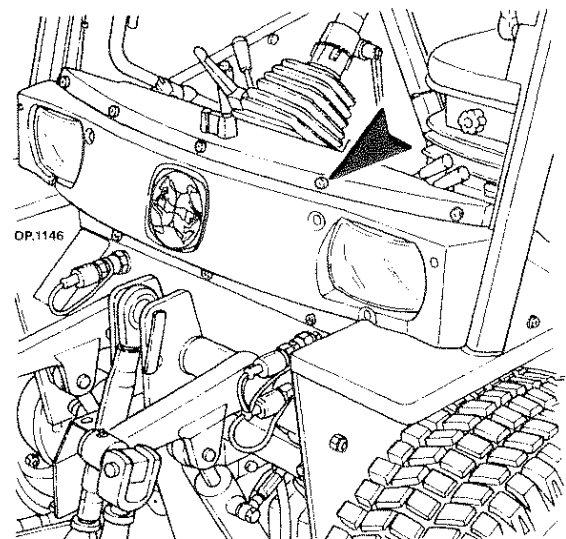

1 - Loosen the screws and remove the cover of the dashboard housing the lights.

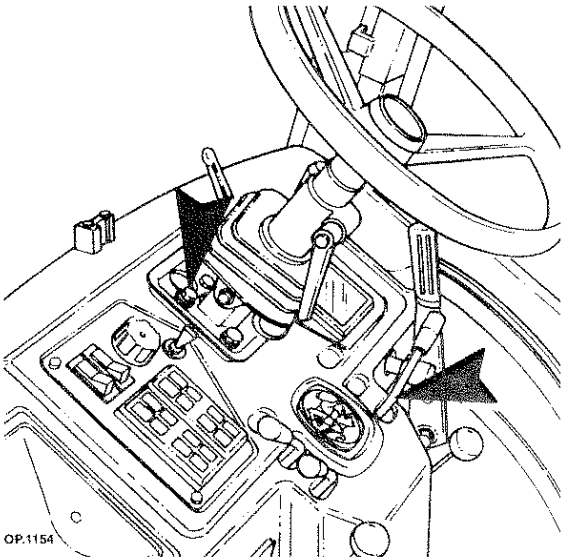

2 - Loosen the screws and remove the whole steering column.

3 - Remove the distributor control knobs.

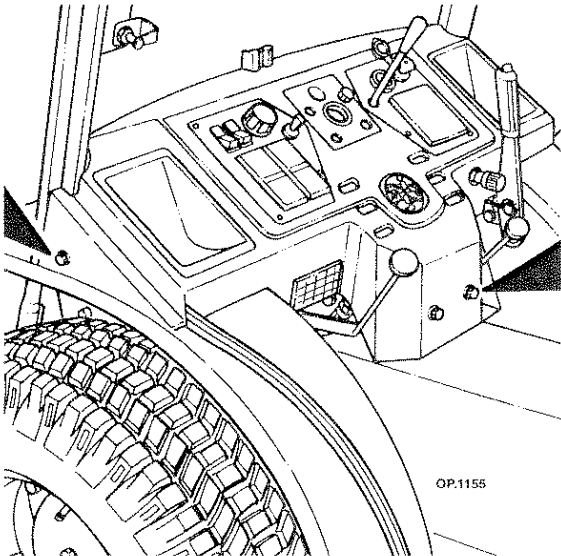

4 - Loosen the screws and remove the instrument console.

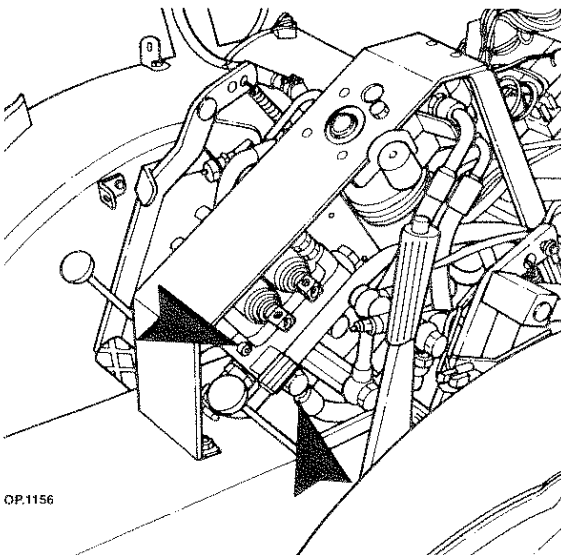

5 - Loosen the oil delivery tubes and drain oil inside a special container.

6 - Loosen the distributor fastening screws and take it out.

Connecting

Hoisting distributor

Tigretrac - Superpark

Connect the distributor following the instructions below:

a - proceed inversely as to the disconnecting operations

b - remember to remove the plugs from the tubes.

c - observe driving torques listed at page 4.

CHECKING OVERPRESSURE VALVE

To check the overpressure of the hydraulic system for hoisting device proceed as follows:

1 - Switch off motor. Detach one of the oil delivery tubes to the hoisting cylinders.

2 - Replace the original fitting with the adapter AT 37981259 and the pressure gauge AT 37981258.

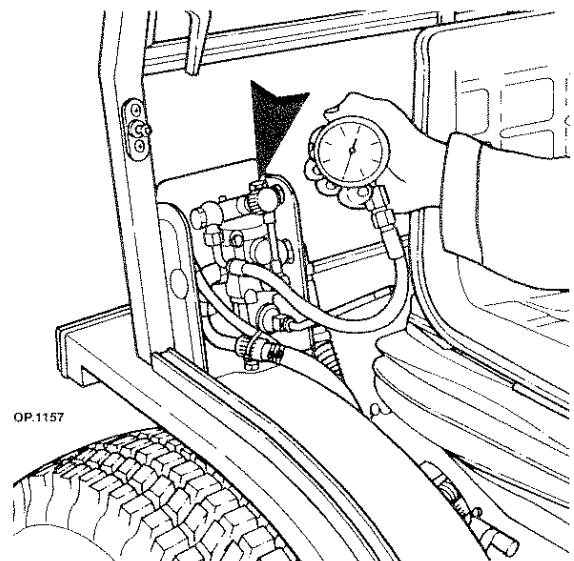

- Check pressure
- Pressure adjustment screws



3 - Start the engine, accelerate until it reaches 1500 rpm and lift the hoisting device until jacks reach end-of-stroke; in this position the overpressure valve steps in and on the pressure gauge you can read the actual pressure.

4 - In case the pressure read differs from the prescribed pressure it is possible to set the valve on the adjustment screw located on the valve gear.

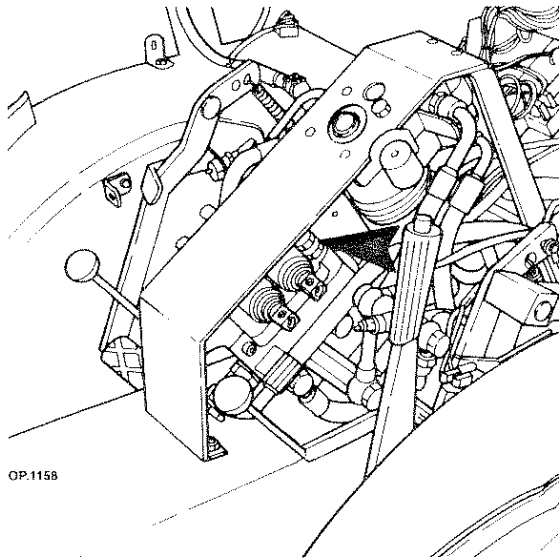

- Pressure adjustment screws (Superpark)

HOISTING DEVICE CYLINDER

Disconnect - connect

To disconnect the hoisting device cylinder, proceed as follows:

1 - Lower the hoisting device.

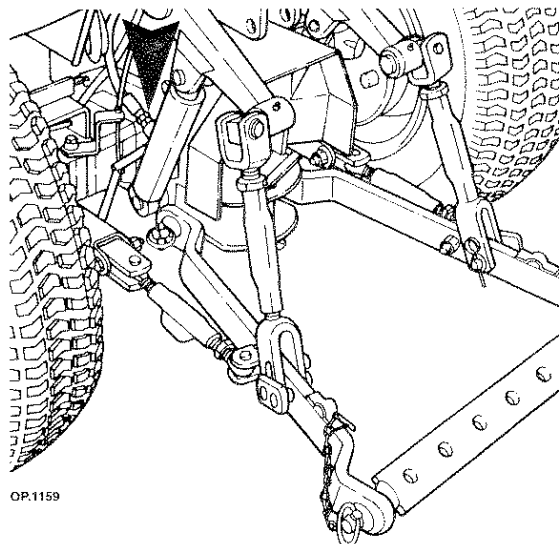

2 - Loosen the cylinder tubes and plug the holes.

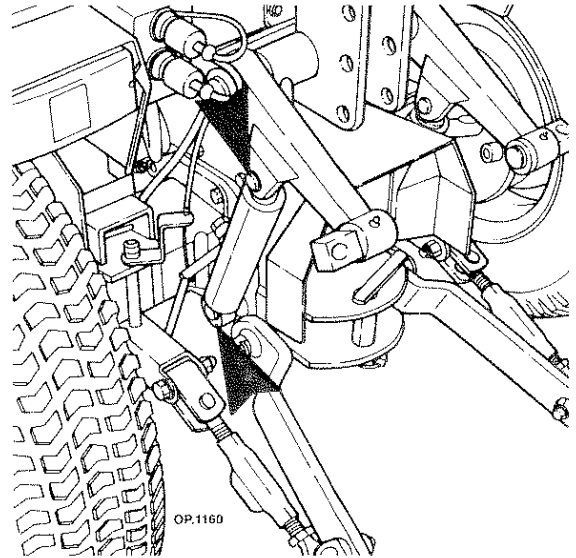

3 - Remove the retainer ring on the cylinder.

4 - Remove the rings on the cylinder rod retainer pin.

5 - Remove the pin.

6 - Remove the hoisting cylinder.

7 - Connect the hoisting device cylinder, taking into account the following operations:

a - proceed inversely as to the disconnection operations

b - grease bushings and splined section bars.

c - observe the driving torques listed at page 4.



WARNING - DANGER



Perform operations by strictly observing accident prevention regulations.

- Wear safety clothing such as gloves and safety shoes.

Watch out for shearing,
Watch out for squeezing,
Watch out for tangling.



Disconnection and connection

Equipment AT 80

To remove the cylinder rod, you must:

1 - Move the rod until it meets with the spring retainer ring towards the oil inlet hole inside the cylinder.

2 - Move ring (2) from the slot with the help of a screwdriver until it fits inside the race.

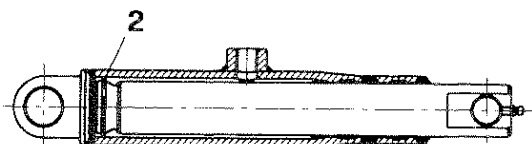

OP.1173

- hoisting cylinder

3 - Remove the rod.

4 - Replace the damages O-rings

5 - Proceed to the assembly, taking into account the following operations:

a - clean carefully.

b - oil the O-rings.

c - proceed inversely as to the disconnection operations.



WARNING - DANGER



Keep environment clean. Dispose of waste fluids, used filter cartridges, oils, lubricants and grease cleaners in the most suitable way and in compliance with regulations in force. The collection of waste oils must be performed by authorized plants.

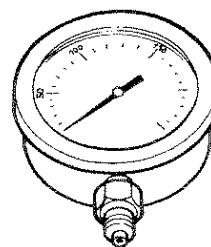

37981258

AT.080

1 - Pressure measuring gauge

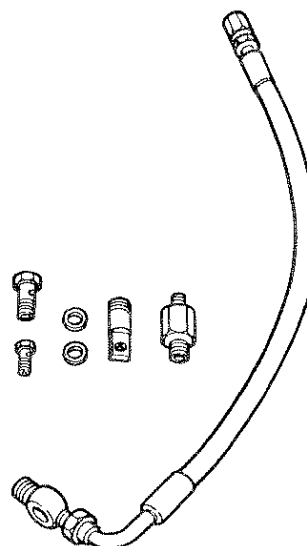

AT.081

37981259

2 - Adapter for pressure gauge.



ELECTRIC SYSTEM

Automobile-type electrical system. It mainly consists of:

a battery, an alternator, a starter, light and indicator system, a fascia panel with control gauges and switches.

It is divided into twelve lines protected by fuses with a main fuse located downstream.

The system operates on 12V.

Technical features

Battery

Type of tractor		Tigretrac 2500	Tigretrac - Superpark 3800
Rated voltage	V	12	12
Rated capacity	Ah	48	70
Discharge intensity	A	230	420
Dimensions	mm	225x220x135	278x190x175
Code		46705005	46705001

Starter

Type of tractor		Tigretrac 2500	Tigretrac - Superpark 3800
Voltage	V	12	12
Rated voltage	V KW	1,1	2,2
Control		Electromagnetic	
Engagement		With traverse and engagement of the pinion	

Alternator

Type of tractor		Tigretrac 2500	Tigretrac - Superpark 3800
Type of alternator		Self-rectifying three-phase type.	
Rated voltage delivered	V	13±14	
Current intensity delivered	A	33	45
Voltage regulator		Electronic built-in the alternator	

**Fuse valves**

Before replacing a blown out valve with another featuring the same amperage, look for the cause of the trouble.

General fuses

60 amp fuses for tractors 2500 - 3800

Fuse valve	Protected circuits	Fuse amperes
1	Front r.h. and rear l.h. sidelights - L.h. work spotlight - numberplate light	15
2	Front l.h. and rear r.h. sidelights - R.h. work spotlight	15
3	Speedometer warning light	7,5
4	Lampalarm - radio - courtesy light (flashing)	10
5	L.h. lower beam	7,5
6	R.h. lower beam	7,5
7	Time and rev. counter - battery gauge - alarm relays	7,5
8	Alarm light - heater	25
9	R.h. and L.h. + warning light upper beam	15
10	Spark plug relays - electrostop - AT warning light body C 1100	7,5
11	Stop - wipers - windshield cleaner	10
12	Horn - Km counter sensor	10

Digital speedometer

The LCD digital speedometer does not require any adjustment.

General technical features

Operation data: Indication field 0-40 Km/h

Rated voltage 12V

Accuracy +/- 0.1 Km/h

Control signal: Honeywell impulse generator

1 GT 101DC coupled with phonic wheel

- 10 teeth



Lighting - indicator system

Two asymmetrical headlight with lower and upper beams, with double-filament light 45/40 W..
Two front lights including: - sidelight (5W light) with white lens; - indicator light (21W light) with orange lens.
Two rear lights including: - sidelights and stop lights (5/21 W light) with red lens; - indicator light (21 W light) with orange lens; - two rear red reflectors.
Number plate light (5W)
Set of optical indicators with 1, 2/3 W for: - Alternator loading (red light) Engine oil pressure low (red light) - Lack of fuel (red light) - Handbrake engagement (red light) - Preheating spark plug switching on (yellow light) - Dry air filter clogging (red light) - Switching on of work rear lights (green light) - Switching on of sidelights (green light) - Switching on of upper beams (blue light) - Switching on of tractor indicator lights (green light) - Switching on of trailer indicator lights (green light) - Switching on of emergency lights (red light) - Clogging of hydrostatic oil filter (yellow light) - High engine water temperature (red light)

Start switch

Switch position	Apparatus engaged
Position 0	No circuit is energized except for the single-pole outlet and lampalarm control (removable key).
Position 1	Starts engine. Operation of the indicators and of the control instruments. Various users energized (key not removable).
Position 2	Starts engine (the key, when released, automatically returns to position 1).
Position P	The light circuit is energized, lighting of dashboard, sidelights, parking lights, number plate and lampalarm control (removable key).

SAFETY FUNCTIONS

Actuation of the buzzer due to the stepping in of the water temperature, oil pressure and air filter clogging warning lights.

It operates simultaneously with the horn and the warning light to indicate the cause and location of the problem; to switch off the horn simply stop and strike the clutch pedal.



CONSOLE WITH CONTROL INSTRUMENTS

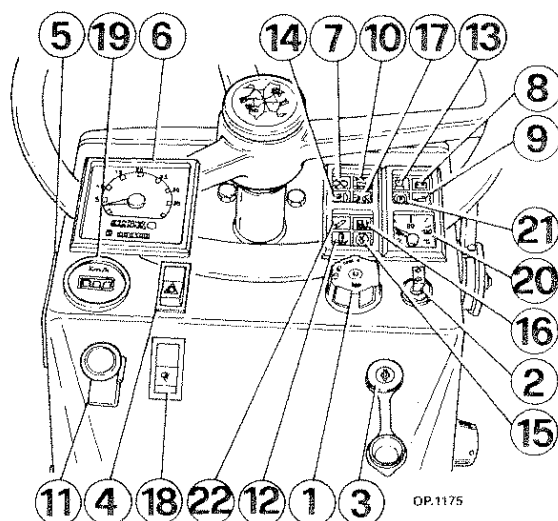

- 1 - Light switch and buzzer
- 2 - Indicator and warning light
- 3 - Start switch
- 4 - Lampalarm switch
- 5 - Protection fuses
- 6 - The time, revolution meter indicates the number of revolutions of the engine and PTO, the speed in Km/h and the functioning hours of vehicle.
- 7 - Indicator lights
- 8 - Battery warning light (red)
- 9 - Oil pressure warning light
- 10 - Trailer indicator lights

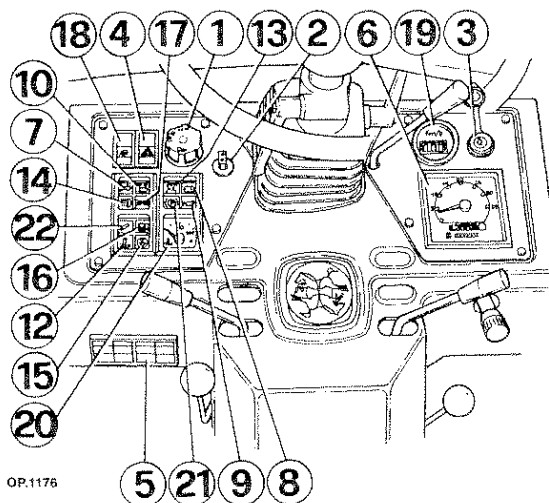

- 11 - Traction disengagement knob
- 12 - Water temperature warning light
- 13 - Pre-heater warning light
- 14 - Upper beams lamp
- 15 - Air filter clogged warning light
- 16 - Fuel gauge
- 17 - Sidelights switch
- 18 - Work spotlights switch
- 19 - Digital speedometer
- 20 - Water temperature gauge
- 21 - Parking brake light
- 22 - Hydrostatic oil filter clogging warning light

Adjustment of engine rpm counter

The time, revolution meter indicates the number of revolutions of the engine and PTO, the speed in Km/h and the functioning hours of vehicle.

To set the rpm meter to the revolutions of the engine, proceed as follows:

- 1 - Apply an implement that measures the engine revolutions.
- 2 - Start the engine and make it run at a speed of 1500 rpm.
- 3 - Check that the time, revolution meter indicates the above mentioned values.
- 4 - In case rpm are different, adjust the time, revolution meter as you can see in the drawing until rpm's are the same on both instruments.

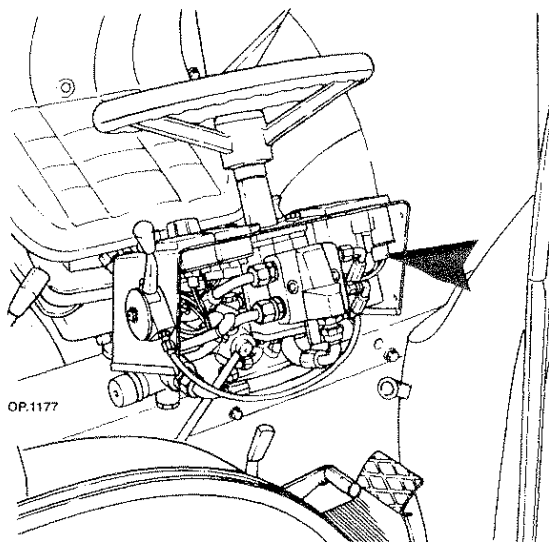

- RPM counter adjustment.



Superpark electric diagram

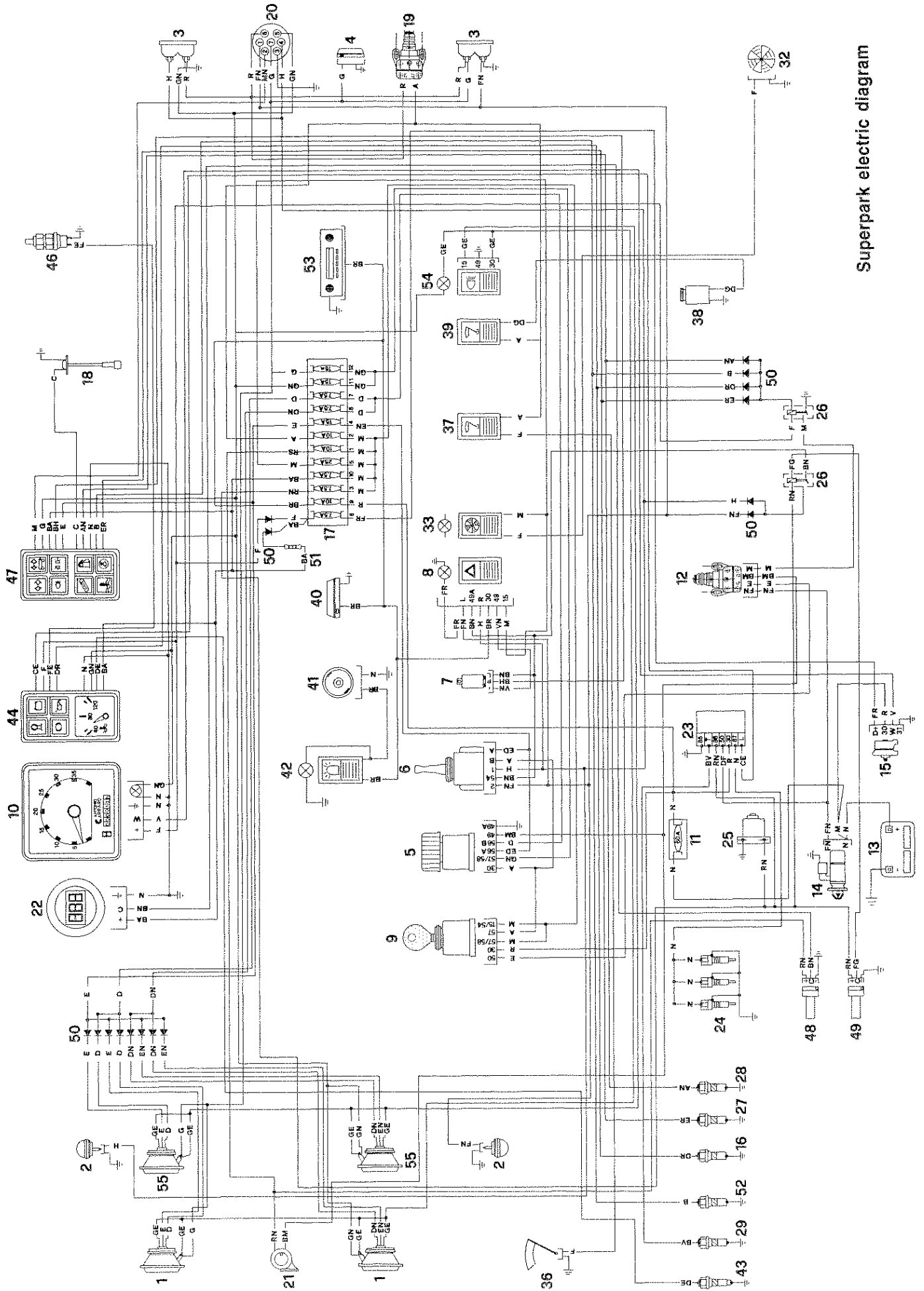



Tigretrac 2500/3800 electric diagram

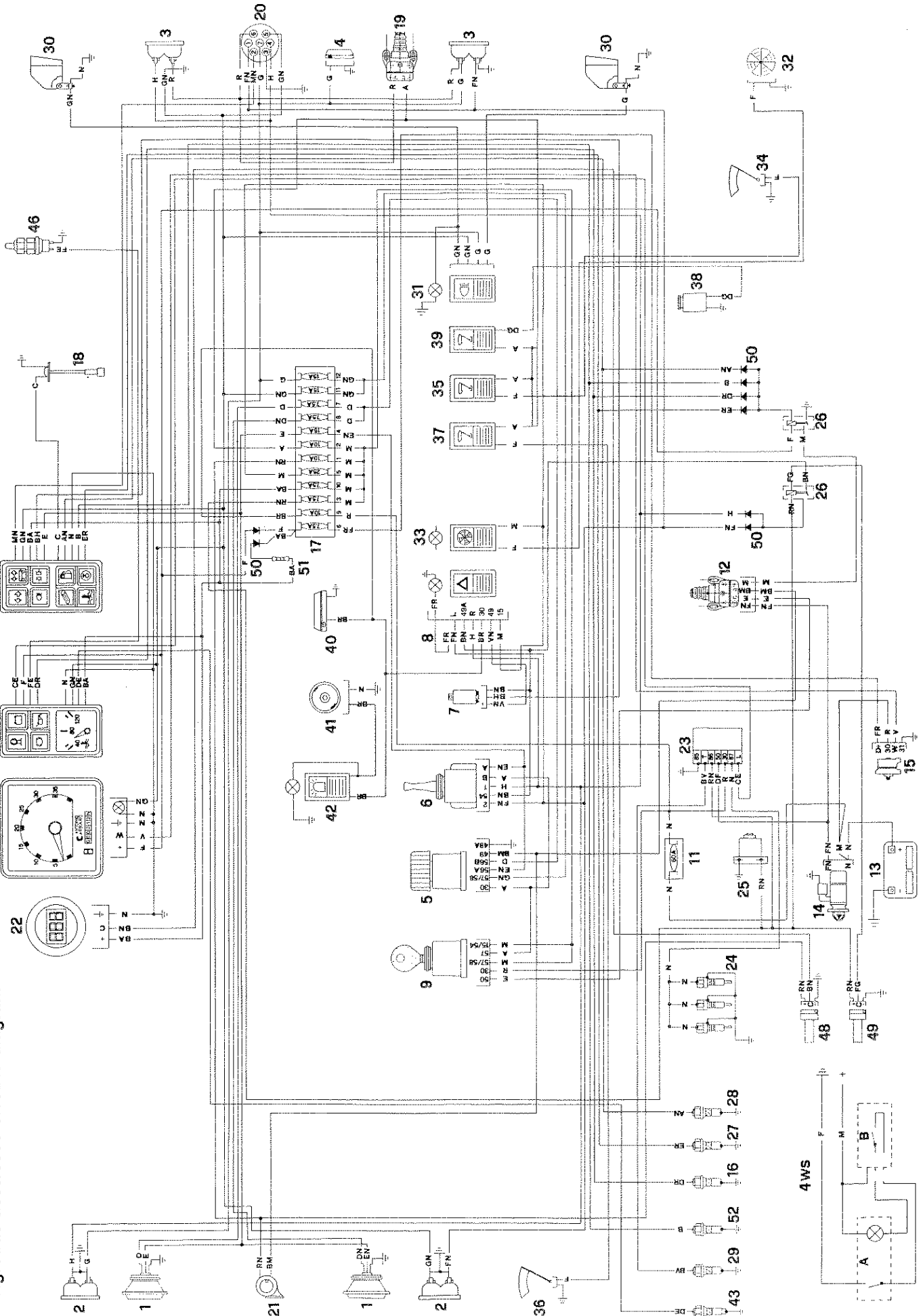



Location of Tigretrac electric system

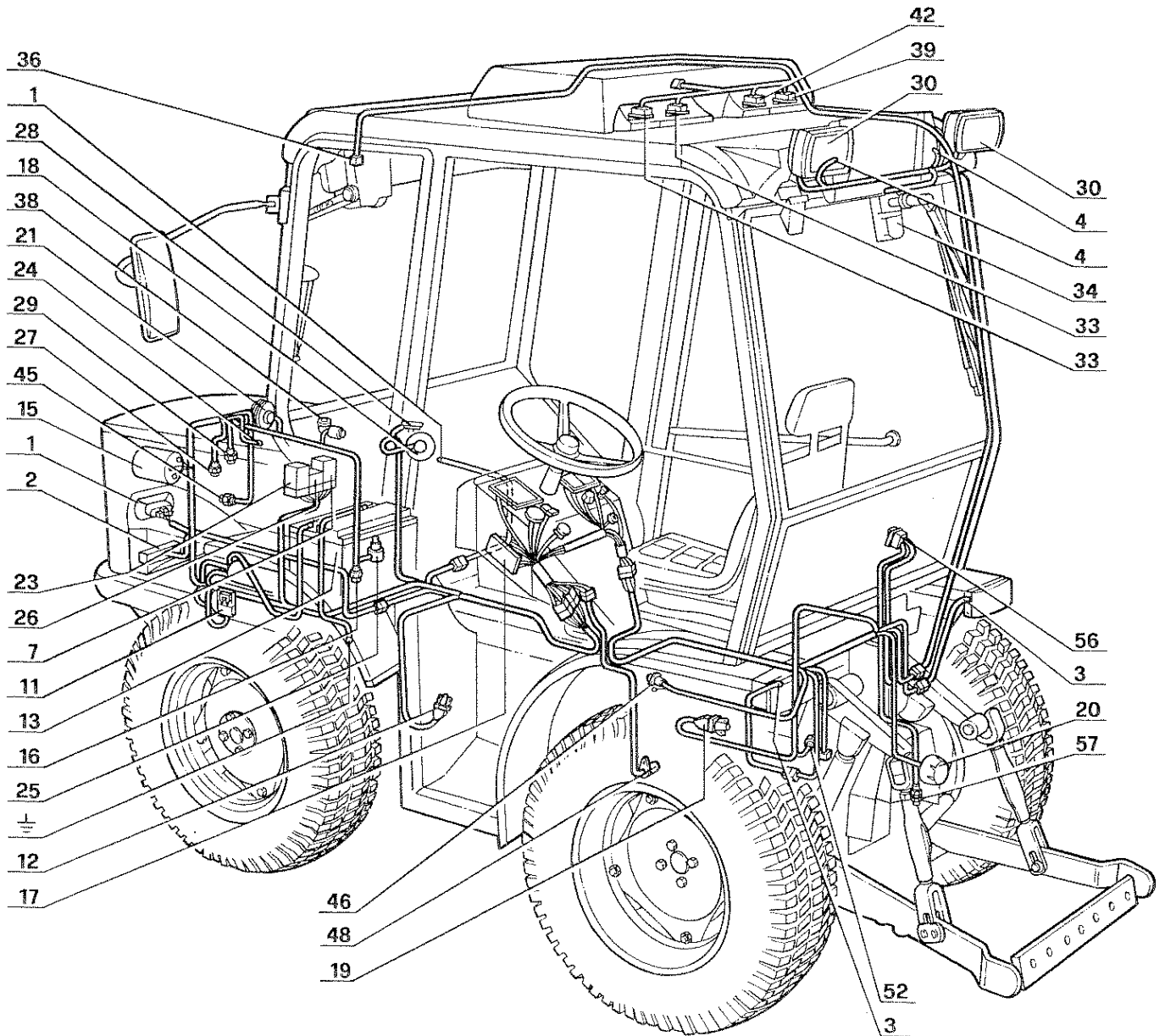



Location of Superpark electric system

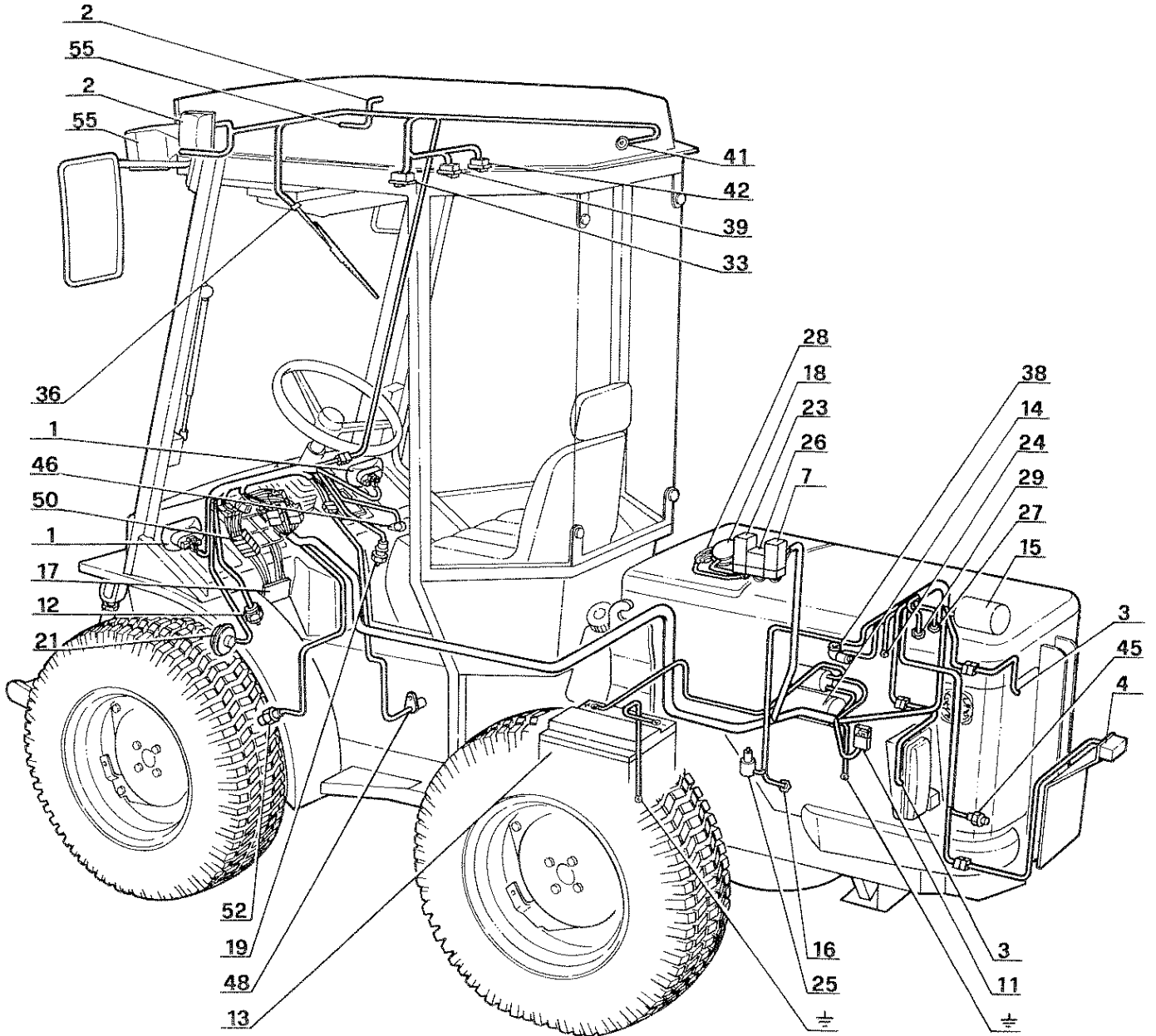



Electric system diagram key

- 1 - Front optical units
- 2 - R.h. - L.h. front turn indicators and sidelights
- 3 - R.h. - L.h. + Stop rear turn indicators and sidelights
- 4 - Number plate lamp
- 5 - Light Distribution panel plus buzzer
- 6 - Indicator switch
- 7 - Hazard flasher switch
- 8 - Emergency switch
- 9 - Start switch
- 10 - Time, rpm meter
- 11 - General fuse
- 12 - Start enable switch
- 13 - Battery
- 14 - Starter
- 15 - Alternator
- 16 - Oil gauge
- 17 - Fuse panel
- 18 - Fuel gauge
- 19 - Stop lights switch
- 20 - 7-pole outlet
- 21 - Horn
- 22 - Digital speedometer
- 23 - Spark plug preheating unit
- 24 - Spark plugs
- 25 - Electrostop switch
- 26 - Relay
- 27 - Water gauge
- 28 - Air filter switch
- 29 - Switch with thermistor for spark plug unit
- 30 - R.h. - L.h. rear work beam
- 31 - Work spotlight switch
- 32 - Fan
- 33 - Fan switch
- 34 - Rear wiper motor
- 35 - Rear wiper switch
- 36 - Front wiper motor
- 37 - Front wiper switch
- 38 - Pump for windshield wiper
- 39 - Windshield wiper switch
- 40 - Cab courtesy light
- 41 - Single-pole plug for connection of rotating light
- 42 - Rotating light switch
- 43 - Electric thermometer for engine water temperature
- 44 - Electric thermometer for water temperature and control lights
- 45 - Water temperature measuring transmitter
- 46 - Hand brake light switch
- 47 - Control lights
- 48 - Proximity sensor for speedometer
- 49 - Proximity sensor for body
- 50 - Diodes
- 51 - Resistance 3W and 2 diodes
- 52 - Electric switch for hydrostatic oil
- 53 - Radio
- 54 - Upper and lower optical units exchange switch
- 55 - Upper optical units
- 56 - Rear wheels alignment control switch on 4WS
- 57 - Sensor for wheel alignment control on 4 SW

Cable colour-coding

A Orange	D Grey	G Yellow	N Black
B White	E Green	H Sky blue	R Red
C Pink	F Dark blue	M Brown	V Violet

Updating the electrical plants

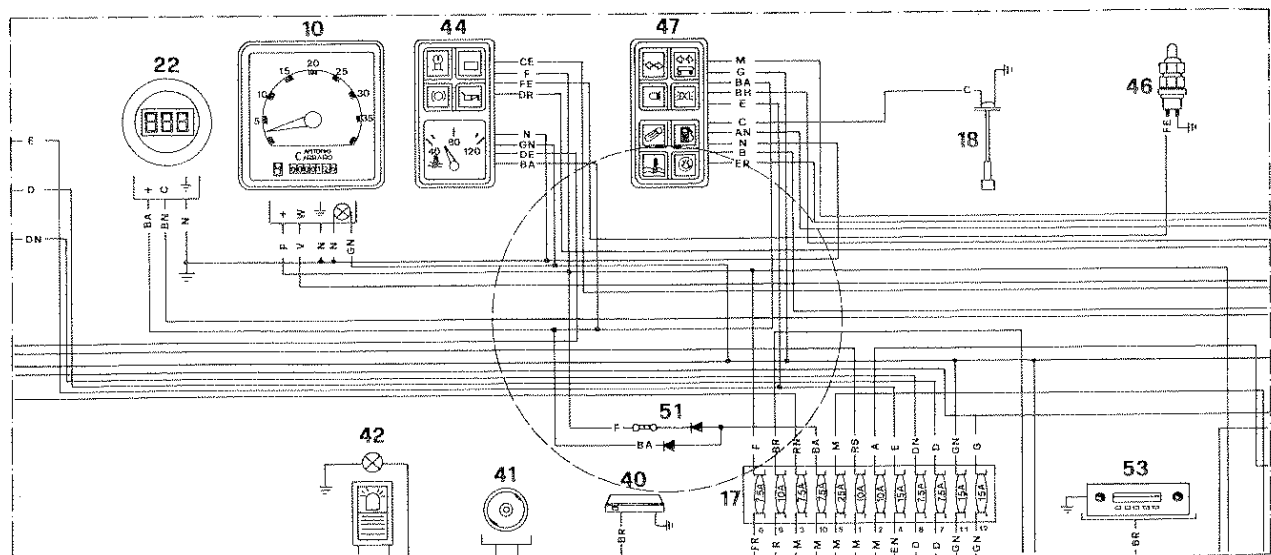



FRONT P.T.O. UNIT ASSEMBLY

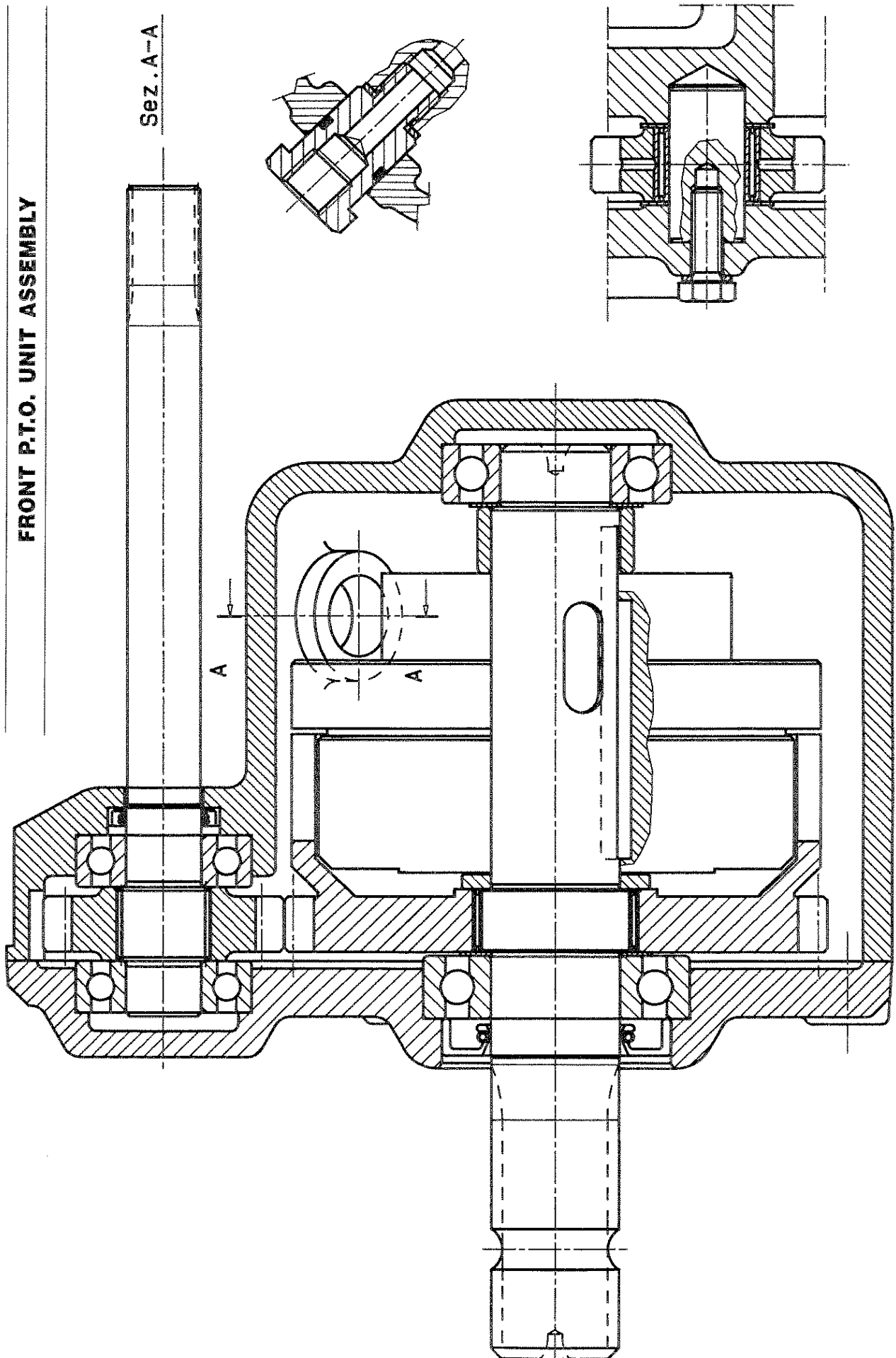



HYDRAULIC DIAGRAM OF HOISTING DEVICE + FRONT P.T.O. UNIT

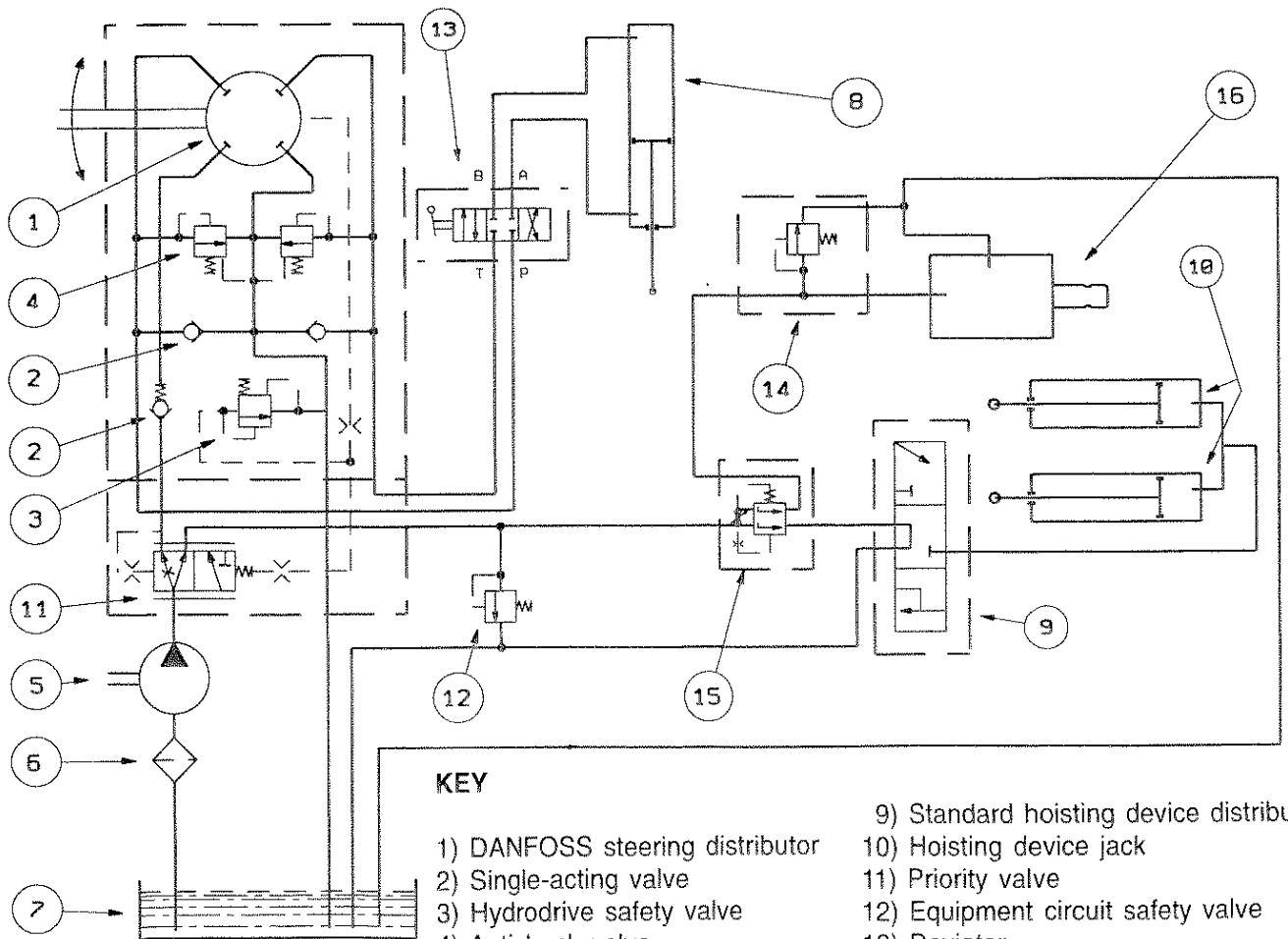
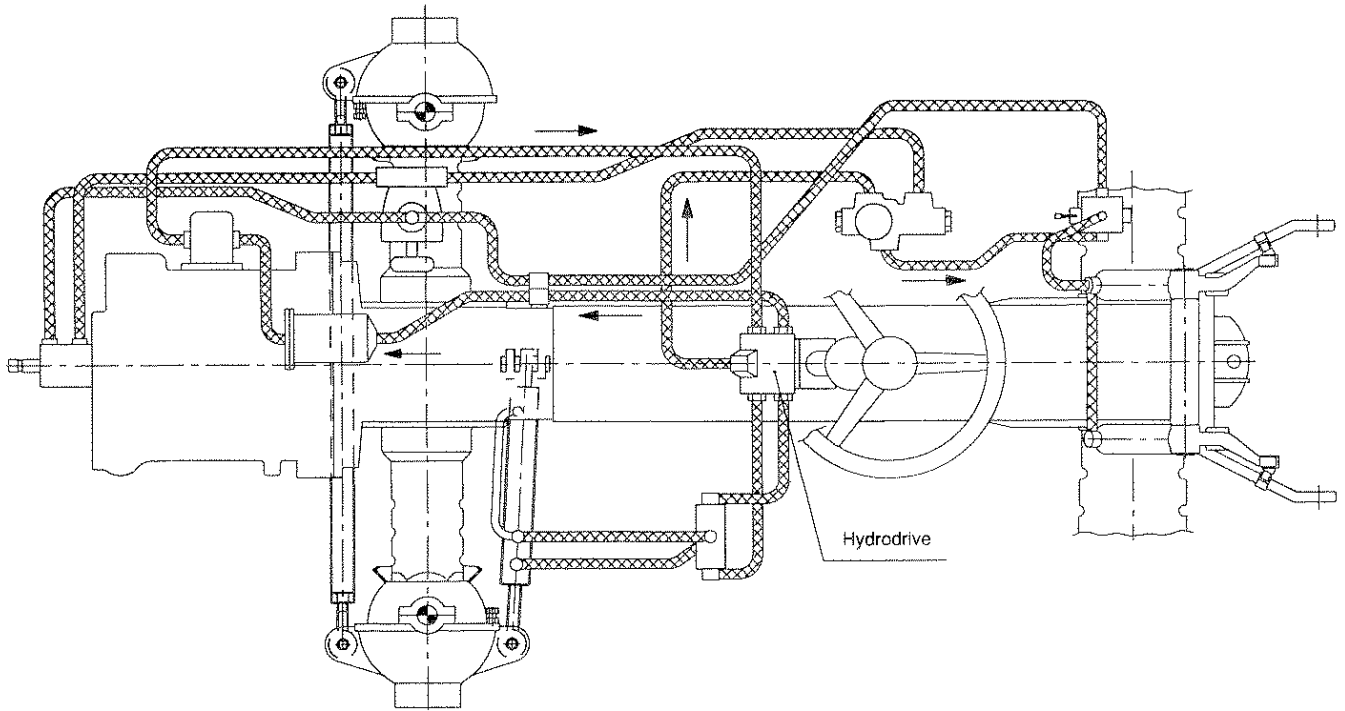

KEY

- | | |
|---------------------------------|---|
| 1) DANFOSS steering distributor | 9) Standard hoisting device distributor |
| 2) Single-acting valve | 10) Hoisting device jack |
| 3) Hydrodrive safety valve | 11) Priority valve |
| 4) Antishock valve | 12) Equipment circuit safety valve |
| 5) Hydraulic pump | 13) Deviator |
| 6) Oil filter | 14) Maximum level valve |
| 7) Oil tank | 15) Priority flow regulator |
| 8) Steering jack | 16) P.T.O. box |



FRONT P.T.O.

The P.T.O. clutch is multi-disc type clutch in oil bath with hydraulic engagement.

The front P.T.O. is directly combined to the engine shaft; the reduction ratio is 1 - 2.5.

The oil used for the operation is the same one used for the hydraulic system of the tractor.

The P.T.O. clutch is controlled by means of a knob.

Disconnecting and connecting the front PTO unit.

To disconnect the PTO unit, proceed as follows:

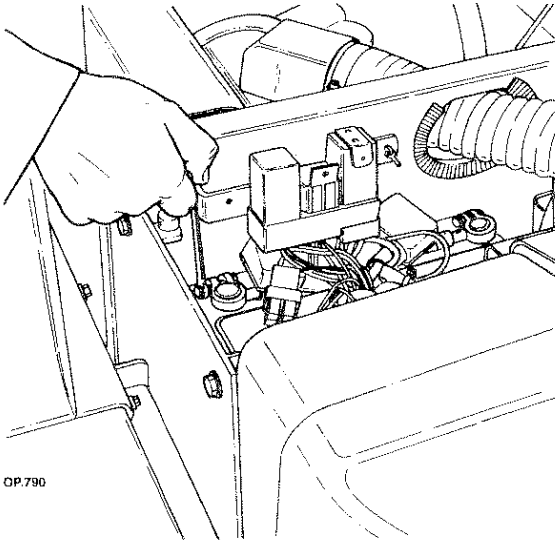

OP.790

1 - Disconnect the battery wire and insulate it.

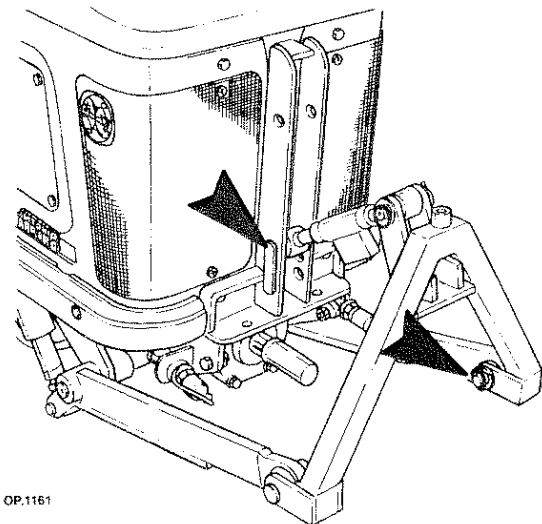

OP.1161

2 - Remove the implement support.

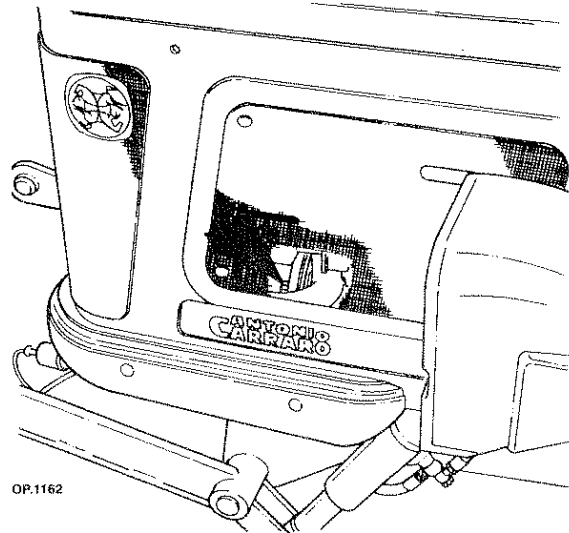

OP.1162

3 - Loosen the screws of the flange on the engine shaft.

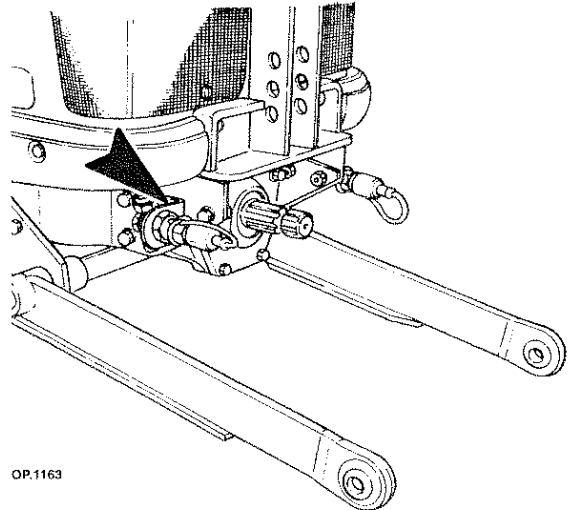

OP.1163

4 - Loosen the screws and remove the hydraulic support.

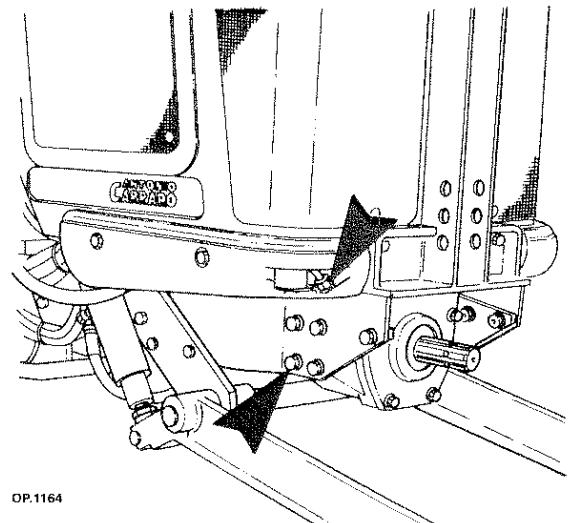

OP.1164

5 - Loosen the delivery tube unions and plug holes with plugs.

6 - Loosen the PTO unit support screws and remove them.



Connecting

Proceed to the connection, taking into consideration the following instructions:

- a - proceed inversely as to the disconnection
- b - grease the grooved contours of the drive couplings
- c - observe the clamping torques listed at page 4.

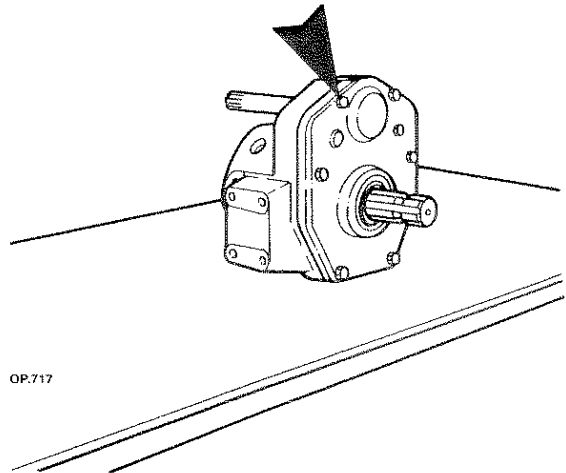

OP.717

4 - Loosen the screws of the unit cover.



WARNING - DANGER



Keep environment clean. Dispose of waste fluids, used filter cartridges, oils, lubricants and grease cleaners in the most suitable way and in compliance with regulations in force. The collection of waste oils must be performed by authorized plants.

Disassembly and assembly of the front PTO unit

For the disassembly of the different components of the PTO unit, proceed as follows:

- 1 - Place the PTO unit on a work bench.
- 2 - Drain oil inside a special container.

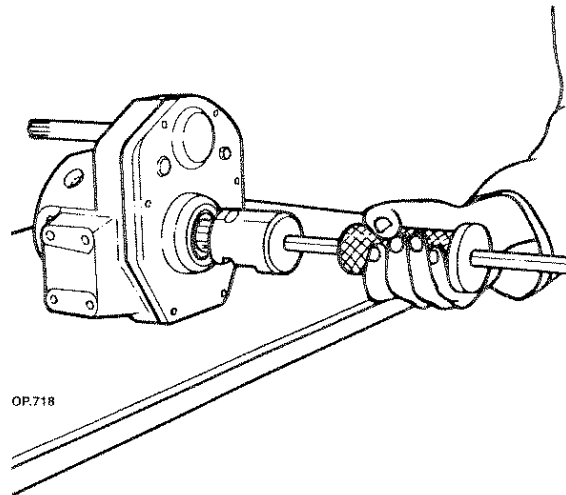

OP.718

5 - With the help of the adapter AT 27981124 and the puller AT 27981047, remove the cover of the unit.

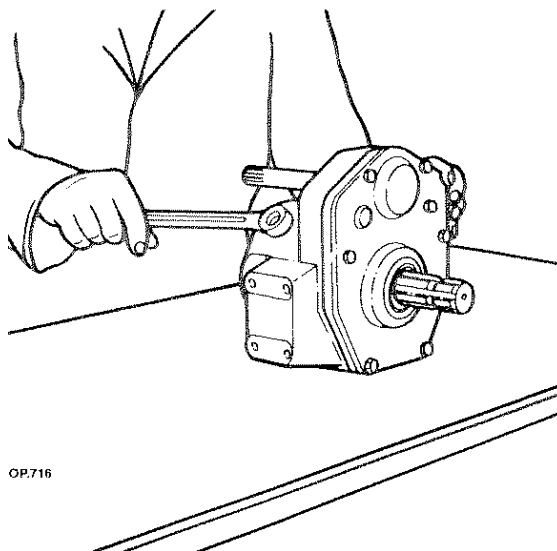

OP.716

3 - Loosen the sleeve that connects the hydraulic system to the clutch unit.

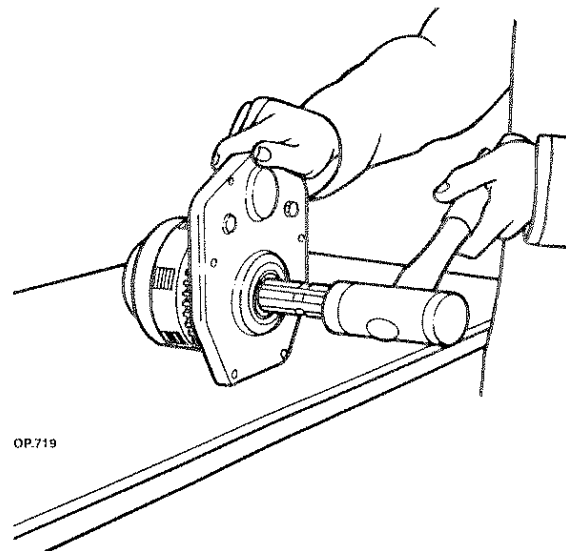

OP.719

6 - With the help of a hammer, remove the clutch unit from the cover.

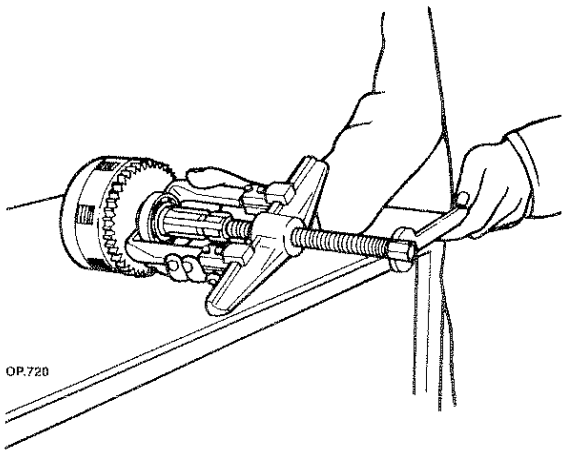

OP.720

7 - Remove the bearing using the universal puller AT 37981247 (large).

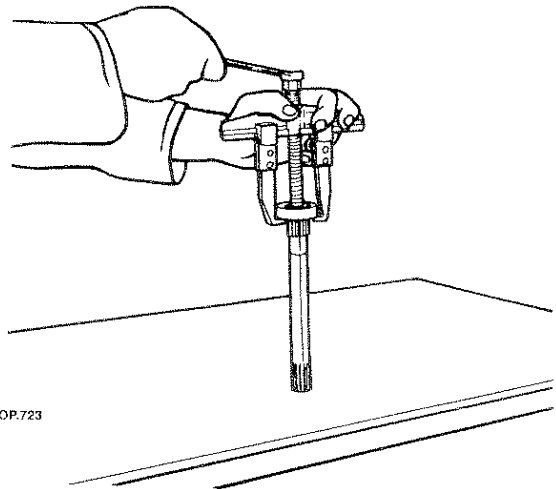

OP.723

10 - Remove the bearing with the universal puller AT 37981257.

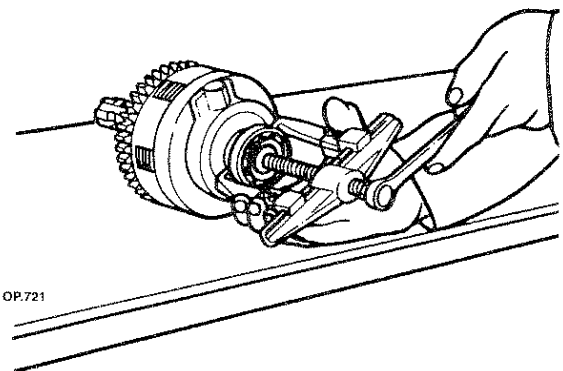

OP.721

8 - Remove the bearing with the help of the puller AT 37981257 (small).

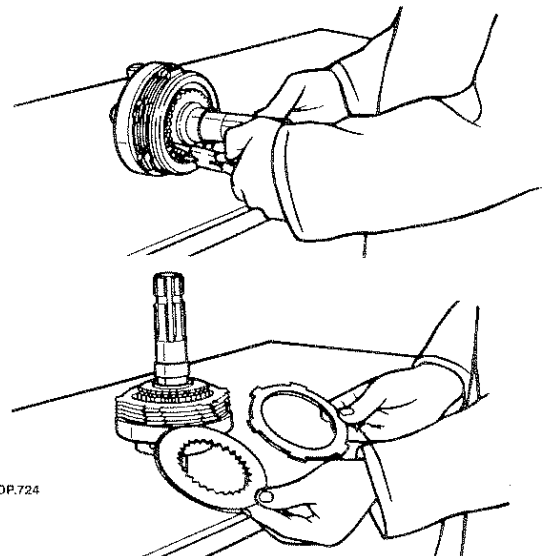

OP.724

11 - Dismantle the clutch unit and check if the sliding surfaces of the clutch discs are worn out or torn, if they are they must be replaced.

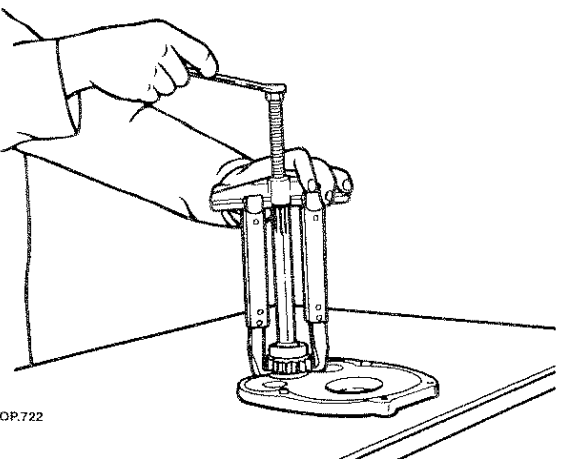

OP.722

9 - Remove the bearing with the universal puller AT 37981257 and the long jaws AT 37981311.

Assembly

Assemble the unit, considering the following instructions:

a - Proceed to the connection, bearing in mind the following instructions:

b - refer to pictures for location of the different components.

c - clean all parts to be mated carefully.

d - apply a 3 mm string of gasket forming

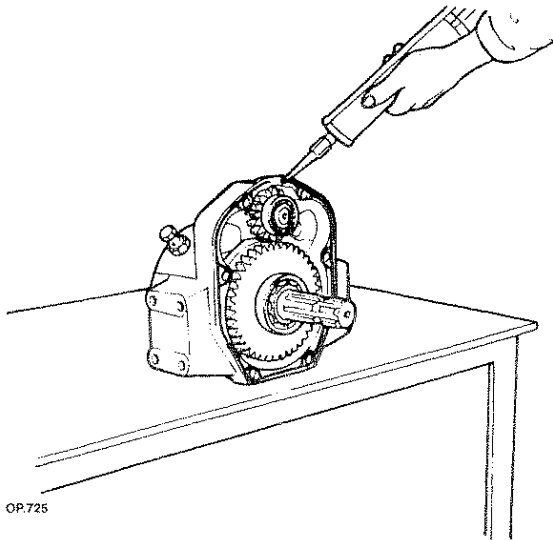

OP.725

compound following the path indicated in the figure.

e - observe the driving torques listed at page 4

f - consider the following operations:



WARNING - DANGER



Perform operations by strictly observing accident prevention regulations.

- Do not use gasoline, diesel oil or other flammable liquids to degrease or clean parts but use commercial non-toxic solvents instead.

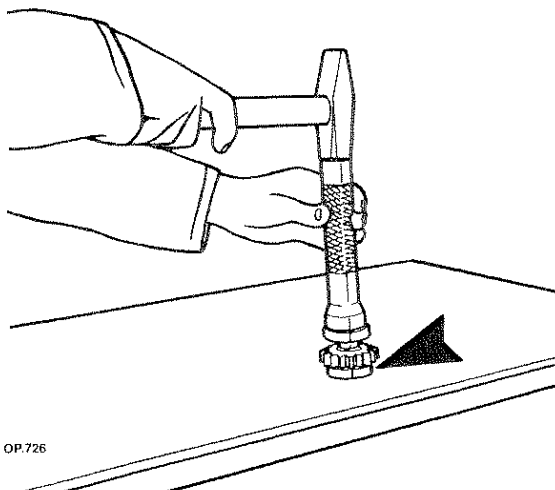

OP.726

12.1 - Mount the bearings on the main shaft with tool AT 37981298.

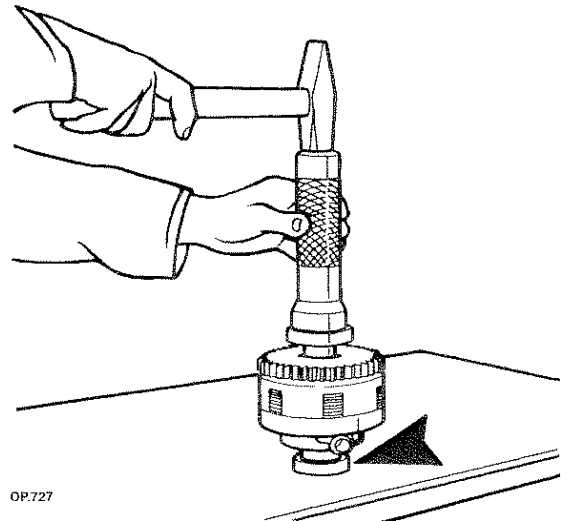

OP.727

12.2 - Mount the bearings on the PTO shaft with tool AT 37981014.

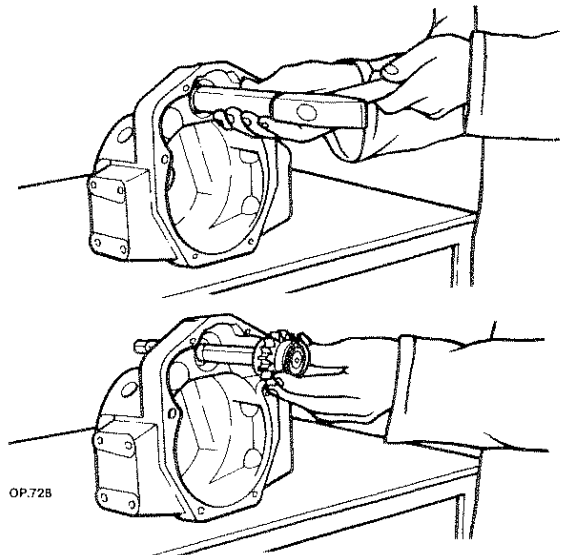

OP.728

12.3 - Mount the seal ring with tool AT 37981299 and insert the main shaft with adapter AT 37981020.

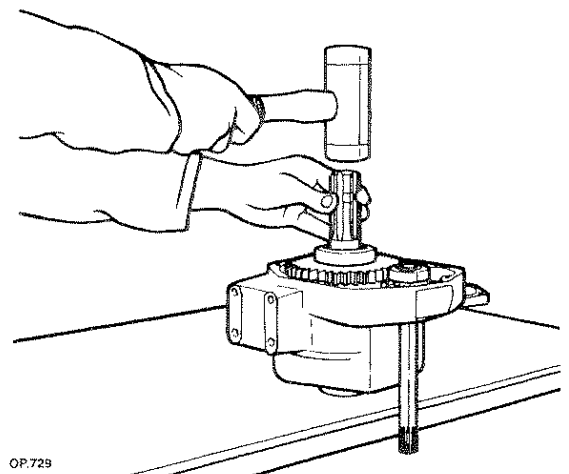

OP.729

12.4 - Mount the clutch unit with a hammer.

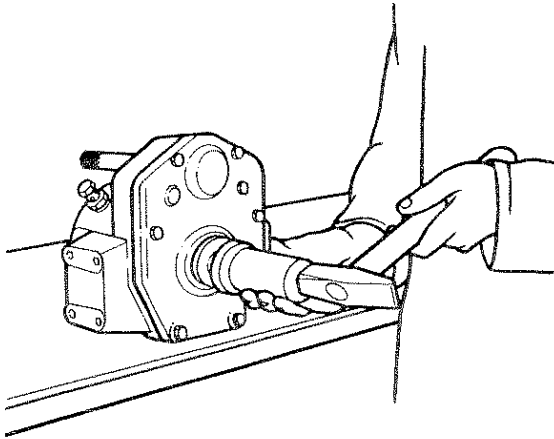

OP.730

12.5 - Mount the seal ring with the help of tool AT 37981301 and adapter AT 37981300 and adding some Loctite inside the seal ring housing.

**WARNING - DANGER**

Perform operations by strictly observing accident prevention regulations.

- Do not use gasoline, diesel oil or other flammable liquids to degrease or clean parts but use commercial non-toxic solvents instead.

The collection of waste oils must be performed by authorized plants.

Keep environment clean.

Checking the actuation pressure of the clutch unit

Check actuation pressure of the clutch unit as follows:

1 - Switch off the motor and dismantle the oil tube connection union of the front PTO unit.

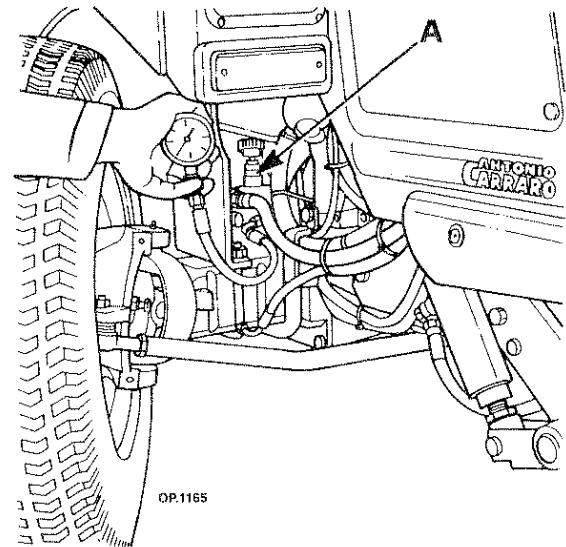

OP.1165

2 - Replace the original fitting with the adapter AT 37981259 and the pressure gauge AT 37981259 connected to the pressure gauge with scale ranging from 0 - 100 Bar AT 37981190 and the tube to the PTO unit.

3 - Start engine and make it run at a speed of 1500 rpm and actuate the control knob; in this condition the pressure gauge must indicate a pressure of 13+/-1 bar (Kg/cm²). In case the pressure differs from the prescribed one adjust it with the help of the valve (see point A).

**WARNING - DANGER**

Perform operations by strictly observing safety and accident prevention measures.

Do not attempt any servicing on tractor unless motor is stopped, except when otherwise specified.

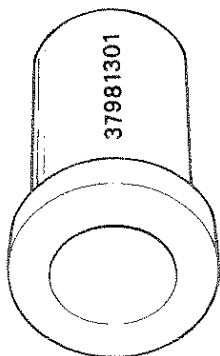

AT.117

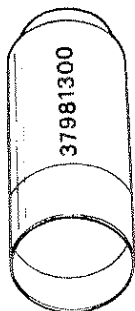

AT.118

1 - Driver AT 379811301 for the assembly of the packings on the PTO shaft and adapter.

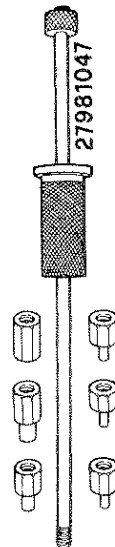

AT.004

4 - Puller with adapter.

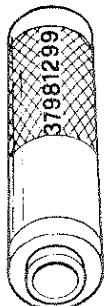

AT.119

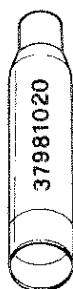

AT.120

2 - Driver AT 37981299 for the assembly of the PTO main shaft packing and adapter.

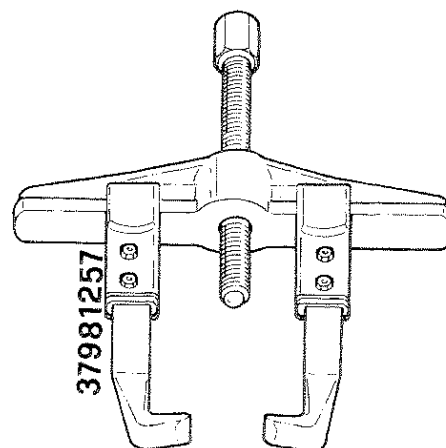

AT.007

5 - Universal puller.

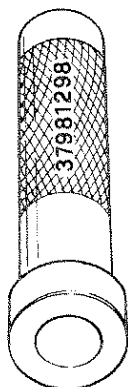

AT.121

3 - Driver for the mounting of bearings.

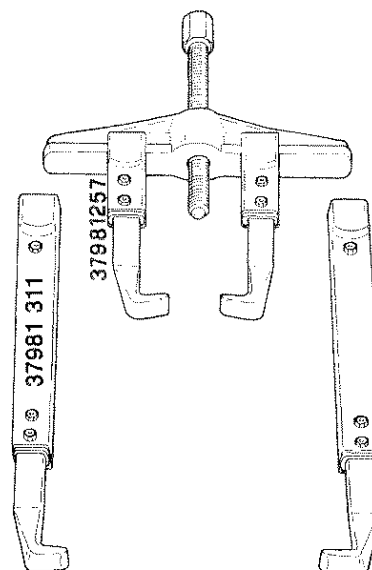

AT.123

6 - Universal puller.

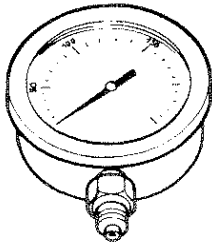

37981190

AT.210

7 - Pressure gauge

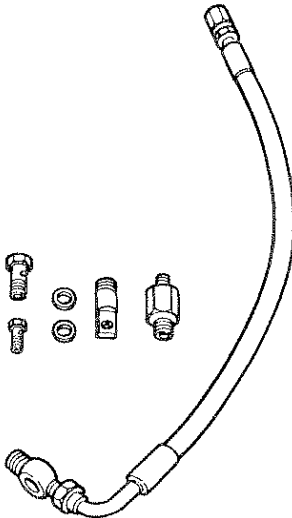

37981259

AT.081

8 - Adapter for pressure gauge

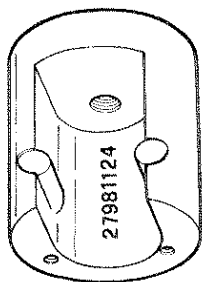

AT.039

9 - Adapter for puller

MEASUREMENT UNIT CURRENTLY USED IN THE AUTO SERVICING FIELD AND RELATIVE ABSOLUTE CONVERSION FACTORS

Size	Unit used		multiply	IS unit	
	Name	Symbol	divide	Name	Symbol
Angle	degree	°	1	degree	°
	first	'	1	first	'
	second	"	1	second	"
Length	millimetre	mm	1	millimetre	mm
	metre	m	1	metre	m
	kilometre	km	1	kilometre	km
	inch	in	25.4	millimetre	mm
	foot	ft	0.3047		
	yard	yd	0.9144	metre	m
	mile (USA)	mile	1.6093	kilometre	km
Area	square millimetre	mm ²	1	square millimetre	mm ²
	square metre	m ²	1	square metre	m ²
	square inch	sq in	645.612	square millimetre	mm ²
	square foot	sq ft	0.0929	square metre	m ²
	square yard	sq yd	0.8361		
Volume	cubic metre	m ³	1	cubic metre	m ³
	cubic inch	cu in	16.3880	cubic centimetre	cm ³
	cubic foot	cu ft	28.3205	cubic decimetre	dm ³
Power	kilogram power	kg	9.8066	Newton	N
	pounds	lb	4.4482		
Electric current	ampere	A	1	ampere	A
Electric power	volt	V	1	volt	V
Impedance Resistance Reactance	ohm	Ω	1	ohm	Ω
Electrical capacity	Farad	F (Farad)	1	farad	F
Frequency	hertz	Hz	1	hertz	Hz
Angle speed	revolutions/sec	rps	1	revolutions/sec	rps
	revolutions/minute	rpm	1	revolutions/minute	rpm



Size	Unit used		multiply	IS unit	
	Name	Symbol	divide	Name	Symbol
			by		
Speed	kilometre/hour	km/h	1	kilometre/hour	km/h
	mile/hour	MPH	1.6092		
Torque - Moment	kilogram-metre	kgm	9.8066	Newton - metre	N - m
	kilogram-centimetre	kgcm	0.1019		
	foot - pound	ft-lb	1.3558		
Stress	kilogram	kg/cm ²	0.0980	Newton	N/mm ²
	square centimetre				
	pound	p.s.i.	0.0068	Square millimetre	
	square inch				
Pressure	kilogram	kg. cm ²	0.9806	bar	bar
	square centimetre				
	atmosphere	atm	1.0132	millibar	mbar
	millimetres of water	mm H ₂ O	0.0980		
	millimetres of mercury	mm Hg	1.3332	bar	bar
	pound	p.s.i.	0.0689		
	square inch				
Flexibility	millimetre	mm/100 kg	0.1019	millimetre 100 Newton	mm/100N
	100 kilograms				
	inch	in/100 lb	57.0125		
	100 pounds				
Capacity	litre	l	1	cubic decimetre	dm ³
	pint	pts	0.5682		
	gallon	imp. gal.	4.5458	cubic centimetre	cm ³
	fluid ounce	fl oz	28.4090		
Time	second	sec	1	second	s
Weight (as body mass)	gram	g	1	gram	g
	kilogram	kg	1	kilogram	kg
	ounce	oz	28.35270	gram	g
	pound	lb	0.4535	kilogram	kg
Power	horsepower	CV	0.7354	Kilowatt	kW
	horsepower	HP	0.7457		
Electric charge (battery)	ampere/hour	Ah	1	ampere/hr	Ah
Electric charge (capacitor)			3.5999	kilo coulomb	kC
Temperature (*)	centigrade	°C	1	centigrade	°C

(*) °F (fahrenheit) = 1.8 °C - 32; °C = $\frac{°F - 32}{1.8}$

SOME FUNDAMENTAL UNITS

Data from:

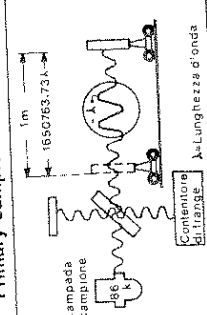
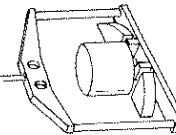
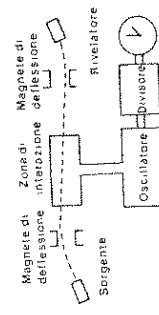
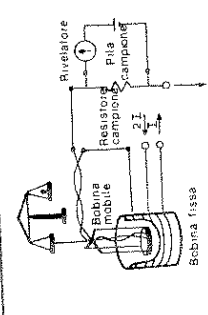
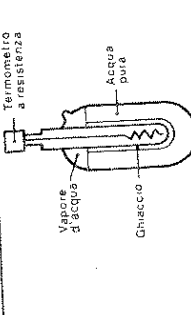
Size	SI unit	Symbol	Definition	Primary sample	Data from:
LENGTH	meter	m	The basic SI unit of length; equal to 1/299 792 458 times the wavelength of the orange light emitted when a gas consisting of the pure Krypton 86 is excited in an electrical discharge.		Data from The Metrological Institute, Gustavo Colonnetti of the CNR - Turin.
MASS	kilogram	Kg	The basic SI unit of mass, equal to the mass of the international prototype stored at the Pavillon de Breteuil (Sèvres, France)		The international prototype consists of a platinum-iridium cylinder on which are based national samples with an estimated uncertainty of 2×10^{-8} . Work samples, in stainless steel or other alloys, are then obtained from the national samples (also in platinum-iridium).
TIME	second	s	The basic SI unit of time: the duration of 9 192 631 770 periods of radiation corresponding to the transition between two hyperfine levels of the ground state of caesium -133.		A "second" is generated by tuning an oscillator on the resonance frequency of the caesium -133 atom. When 9 192 631 770 oscillations are produced, the clock indicates that a time period equal to a second has elapsed. The uncertainty with which it is possible to measure the time periods greater than 1000 with an estimated uncertainty of 1×10^{-12} .
ELECTRIC CURRENT	ampere	A	The basic SI unit of electric current; the constant current that, when maintained in two parallel conductors of infinite length and negligible cross section placed 1 metre apart in free space, produces a force of 2×10^{-7} newton per metre between them.		An "ampere" is generated by using an electromagnetic scale, on which, known the local gravity acceleration and with reference to the mass sample, it is possible to measure the interactional force between the fixed coil and a movable one and from which you can calculate the value of electric current in the coil, with an estimated uncertainty of 4×10^{-8} .
THERMODYNAMIC TEMPERATURE	Kelvin	K	The basic SI unit of thermodynamic temperature; the fraction (1/273.16) of the thermodynamic temperature of the triple point of water.		The thermodynamic temperature of the triple point of water, characterised by the coexistence in equilibrium of the three phases: solid, liquid, steam is achieved in airtight glass bulbs containing extremely pure water, bulbs that allow the generation of the Kelvin with an estimated uncertainty of 4×10^{-7} .

National Electrotechnical Institute Galileo Ferraris - Turin.

National Electrotechnical Institute Galileo Ferraris - Turin.

Data from The Metrological Institute, Gustavo Colonnetti of the CNR - Turin.



ROAD CIRCULATION WITH REVERSED GEAR

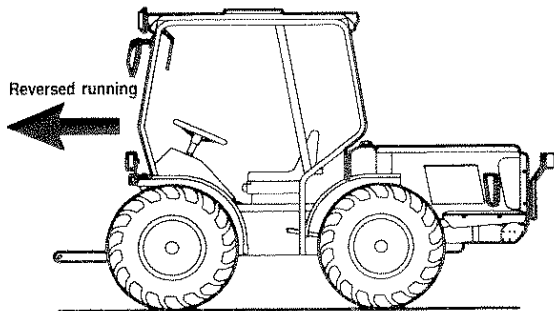
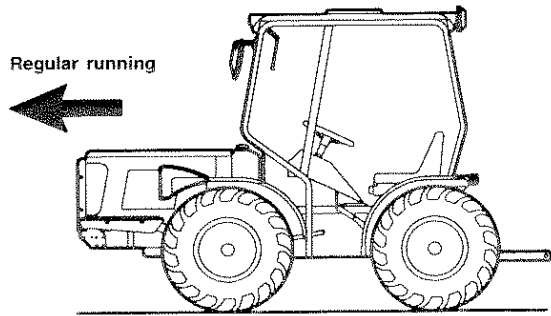

- Instructions to be followed to change lights and indicators when circulating on roads with reversed gear.

Proceed as follows:

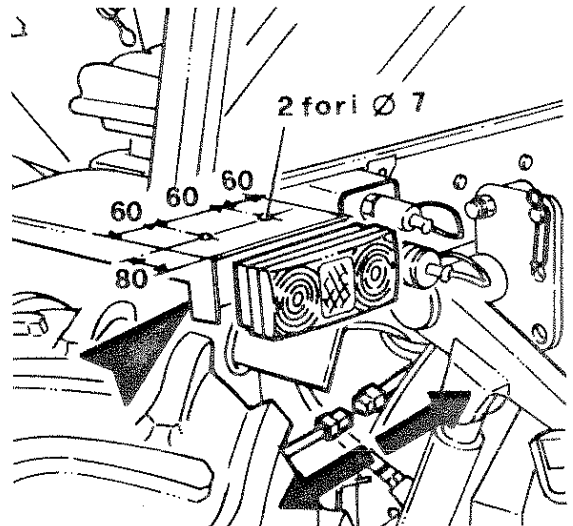

1 - Remove the rear light and drill two holes $\text{Ø } 7$ on the bumper as shown in the figure.

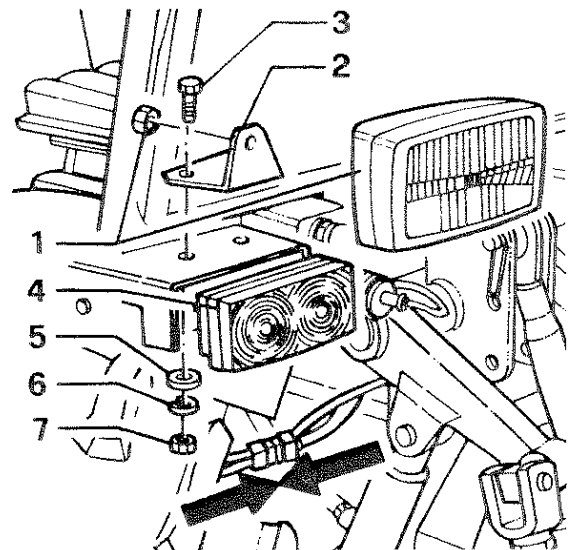

2 - Mount the front indicator and sidelight and the front headlight with relative support.

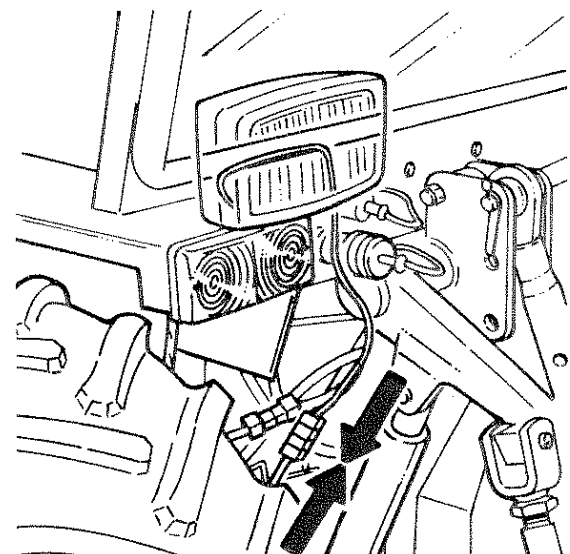

3 - Position the wire of the headlight according to the diagram and connect.

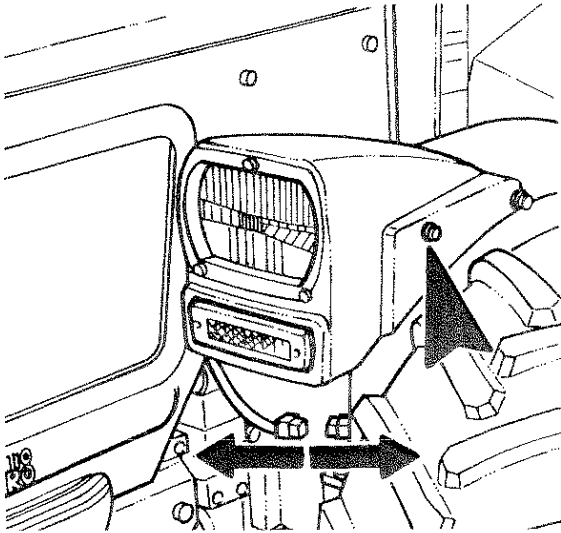

4 - Disconnect the electrical connections and remove the whole unit supporting the front headlights and turn indicator.

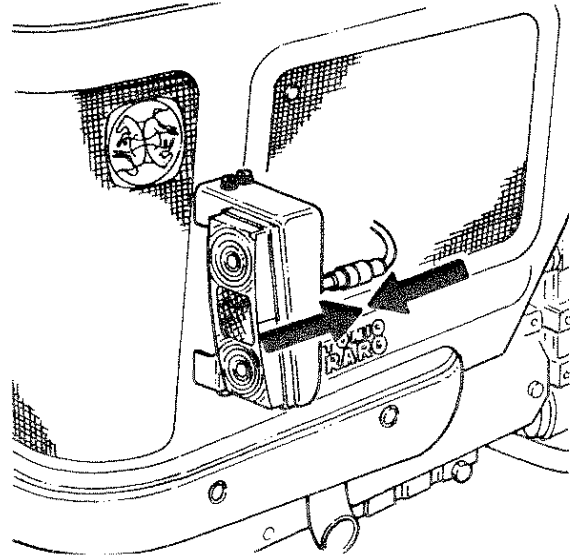

7 - Connect wires.

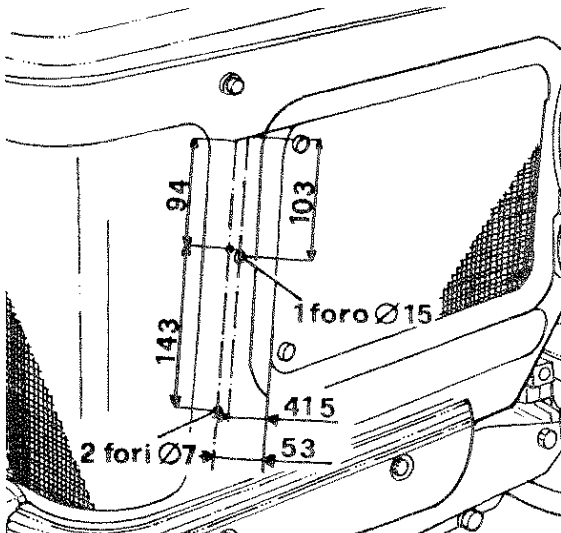

5 - Remove the protection grille and drill two holes; Ø 7 and Ø 15 as shown in the diagram.

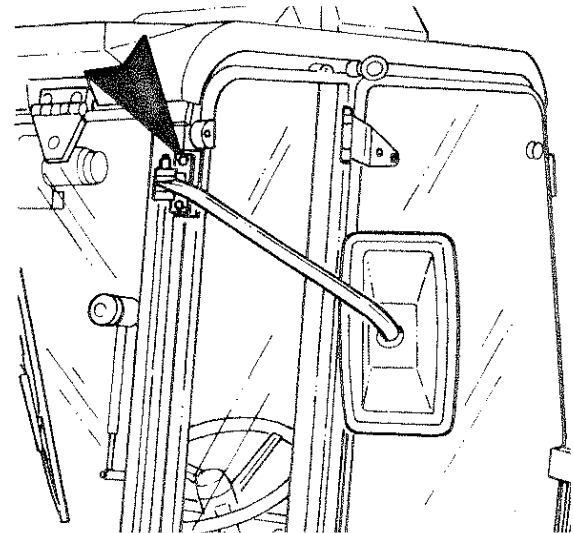

8 - Loosen the screws and remove the rearview mirror.

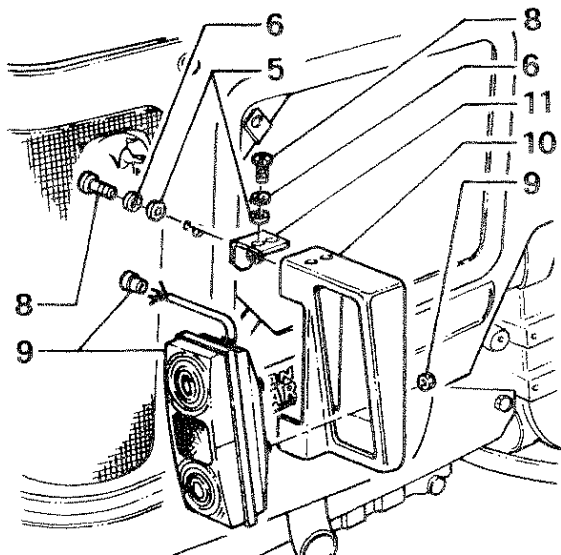

6 - Mount the rear stop and sidelight with reflector.

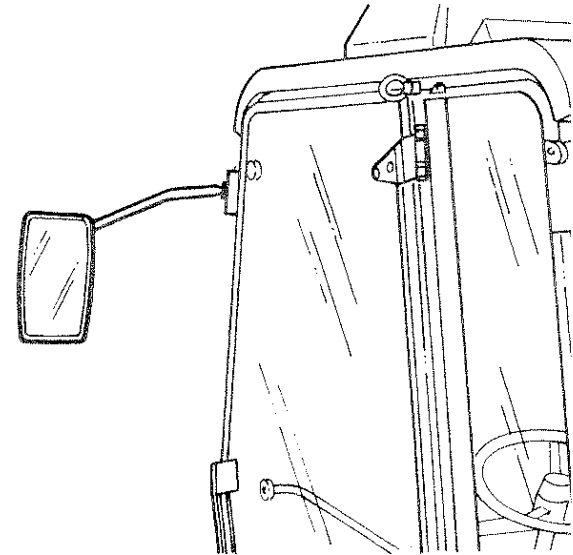

9 - Mount the rearview mirror in the reversed drive position.

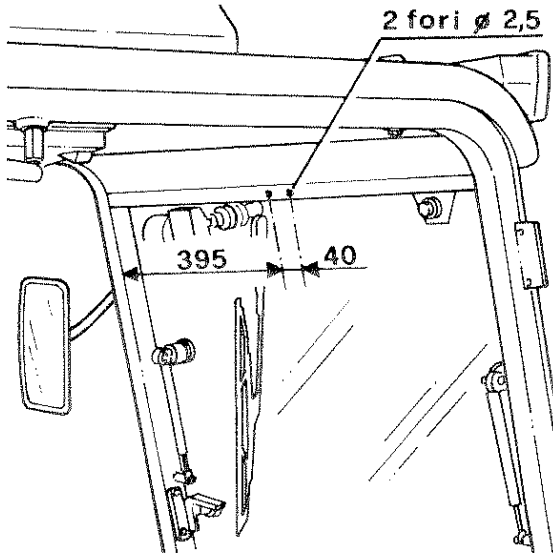

10 - Drill two holes 2.5 as per diagram.

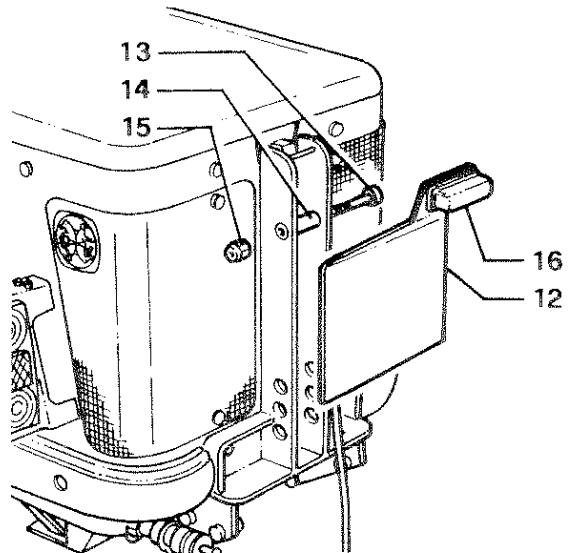

13 - Mount the rear number plate support together with light.

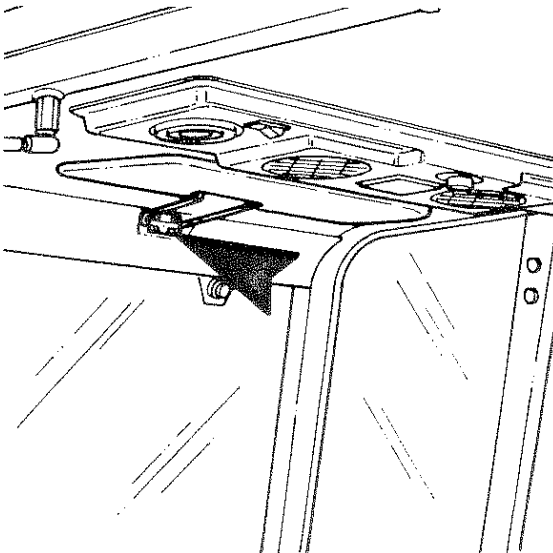

11 - Loosen the screws and remove the padded visor.

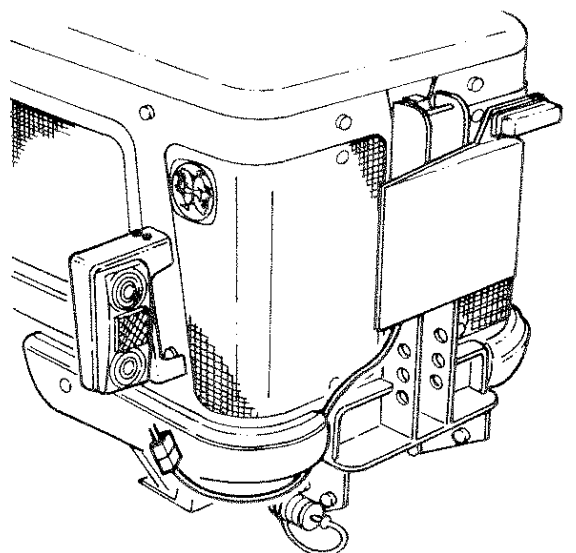

14 - Connect wires.

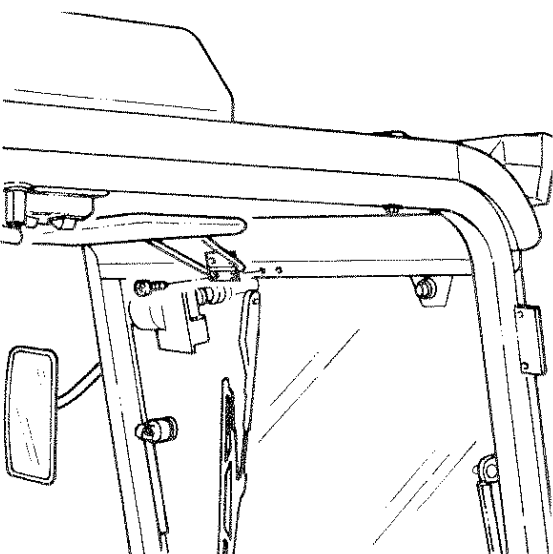

12 - Mount the padded visor in the reversed drive position.

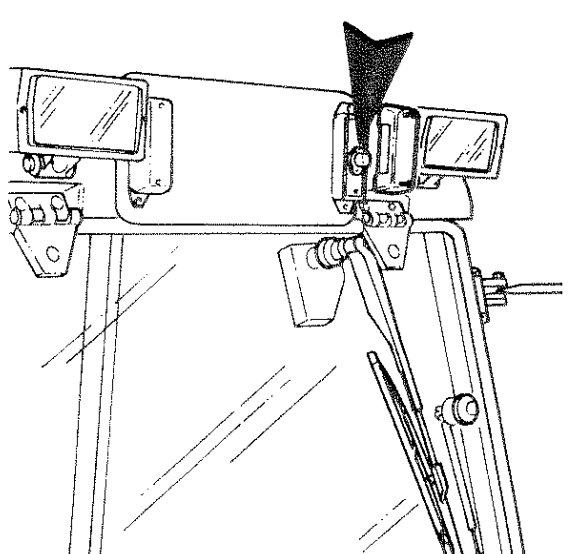

15 - Loosen screws and remove both the lights of the "front" number-plate lights.

**Note**

When installation has been completed, check the efficiency of the lighting system before using the tractor, and adjust the front headlight 1 in compliance with the road circulation regulations in force.

**WARNING - DANGER**

Perform operations by strictly observing safety and accident prevention measures. Do not attempt any servicing on tractor unless motor is stopped, except when otherwise specified.

Key - Kit for the application of the lights with reversed drive

Ref. Item	Quantity	Code	Description of item
-	1	16701121	Kit for the application of rear lights
1	2	46706058	NIOX front headlights
2	2	34909757	Support for NIOX headlights
3	4	46966008	Screw M6x20
4	2	46706052	Front light turn indicator
5	16	6205542	Flat washer D.6 UNI 6592
6	16	6206532	Grower washer D.6 UNI 1751
7	4	6197558	Nut M6 high UNI 5587
8	12	46966012	Screw M6x14 UNI7687
9	2	46706027	Turn indicator-stop parking rear light
10 S	1	46706030	Rear light l.h. support
10 D	1	46706031	Rear light r.h. support
11 S	2	34904556	Rear light l.h. support angle
11 D	2	34904557	Rear light r.h. support angle
12	1	35018023	Number plate bracket
13	1	46960053	Screw
14	1	32205265	Bushing
15	1	6198503	Nut
16	1	46706012	Complete number plate lamp (lights - 5 fastening nuts - 750 mm cable with male Faston connectors and relative 2-pole connector).

Note: This application has been designed for all Tigretac series 30 serial no. 02457.



Antonio Carraro spa
Via Caltana 24 - 35011 Campodarsego - Padova
Telefono 049/921 9 921 - Telex 430011 Catrat I - Telefax 049/921 99 99