

Parts & Installation Instructions

Meyer Drive Pro™ Moldboard

Model DP 5'-0", 6'-0" & DP 6'-8"

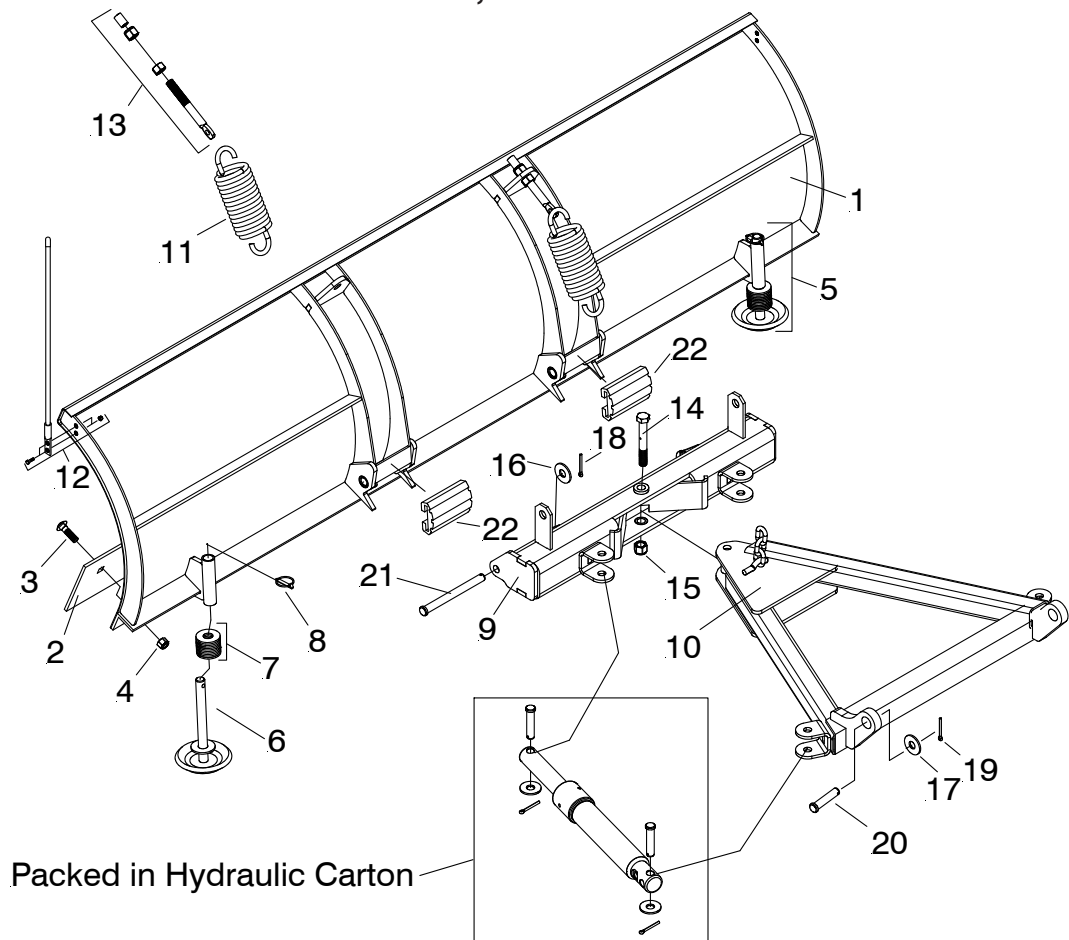

Parts List

Item	DP 5'-0" Part No.	DP 6'-0" Part No.	DP 6'-8" Part No.	Qty.	Description
1	09320	09270	09274		Drive Pro™ Moldboard Assembly
2	09319	09271	09277	1	• Cutting Edge
3	21943	21943	21943	6	• Bolt C 1/2-13 x 1-3/4" Gr. 5
4	20307	20307	20307	6	• Locknut 1/2-13
5	09127	09127	09127	2	• Runner Assembly
6	10853	10853	10853	1	• Mushroom Weldment
7	20359	20359	20359	11	• Flatwasher 3/4"
8	22083	22083	22083	1	• Lynch Pin
	16600	16600	16600		Drive Pro™ PAF Carton
9	12959	12959	12959	1	• Drive Pro™ Pivot Bar
10	13596	13596	13596	1	• Drive Pro™ A-Frame
11	12978	12978	12978	2	• Trip Spring
	08140	08140	08140	1	• Hardware Bag
12	08852	08852	08852	1	• Plow Marker Kit
13	09124	09124	09124	2	• Eye Bolt
14	22005	22005	22005	1	• Bolt H 5/8-11 x 5-1/2" Gr. 8
15	20309	20309	20309	1	• Locknut 5/8-11
16	20357	20357	20357	2	• Flatwasher 5/8"
17	20361	20361	20361	2	• Flatwasher 1"
18	20385	20385	20385	2	• Cotter Pin 1/8 x 1-1/4"
19	20420	20420	20420	2	• Cotter Pin 1/4 x 2"
20	22436	22436	22436	2	• Pin 1 x 3"
21	22720	22720	22720	2	• Pivot Pin 5/8 x 7"
22	22686	22686	22686	2	• Trip Bumper

Parts indented are included in the assembly under which they are indented.

INSTALLATION INSTRUCTIONS

- A. Attach Trip Bumper (22) to flat plate in front of pivot tubes of Moldboard (1).
- B. Attach pivot bar (9) to Moldboard (1) using pivot pins (21) coated with chassis lubricant, 5/8" Flatwasher (16) and 1/8 x 1-1/4" Cotter Pin (18).
(Note: Grease hole on moldboard pivot tube)
- C. Attach trip springs (11) to pivot bar (9) and moldboard (1) with eye bolts (13). Flat end of eye bolt (13) must be in a vertical position, as shown in Figure 2, to hinge properly when moldboard (1) trips. Proper tension is attained when trip spring (11) coils begin to separate and then tighten top locknut four additional turns. Tighten bottom Finish nut to secure eye bolt (13) in position. Install Eye Bolt Caps over threads.
- D. Assemble A-Frame (10) to pivot bar (9) using Bolt (14) and locknut (15).
- E. Install power angling rams with hoses to A-Frame (10) and piston end of ram to pivot bar (9) using hardware bag packed in the Hydraulic Carton.
- F. Straighten end of plow markers (8) so they will be vertical after installation. Attach using 1/4-20 x 1" bolt, clamp, lockwasher and nut.
- G. Secure the moldboard-pivot bar-A-frame assembly to vehicle at the clevis frame using pins (20), 1" Flatwasher (17) and 1/4 x 2" cotter pin (19). Attach lift chain to lift arm allowing sufficient slack to allow moldboard to follow ground contours.

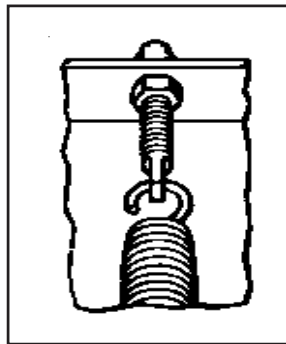

Figure 2

Meyer Products LLC
18513 Euclid Ave. • Cleveland, Ohio 44112-1084
Phone 486-1313 (Area Code 216)
www.meyerproducts.com • email info@meyerproducts.com

Meyer[®]

Meyer Products LLC
6 Angell Lane • Damariscotta, ME 04543-4507
Phone 563-2227 (Area Code 207)
www.meyerproducts.com • email info@meyerproducts.com